



## WA-SERIES WRAP AROUND CARTONER



### *Unique, Cost Effective Packaging*

The ADCO WA-series Wrap Around cartoner combines proven engineering technology and simplicity of design to produce a robust wrap around sleeve machine that offers its customers both an outstanding machine value as well as increased paperboard savings. The WA-series can easily wrap a wide variety of product configurations ranging from single packs to inverted stacked multi-packs. Wrap Around cartons offer companies a unique way to display their products while reducing paperboard cost and waste for greater efficiency compared to traditional end load cartons. The ADCO WA-series of cartoners has packed almost every type of product container available including bottles, cans, cups, tubs, trays, and even flexible pouches.

Standard machine features include ADCO's durable line shaft and gearbox internal drive system, multi-head rotary carton feeder, horizontal powered carton hopper, group

lubrication system for bearings and chains, and a product infeed conveyor with automatic speed control for smooth line operation that is controlled by the incoming product supply.

Product indexing features include dual timing screws for positive indexing with "quick change" mounts, servo-powered starwheels or flighted side chain indexing – depending on the product to be run.

Optional features include: washdown construction with stainless steel frame and NEMA 4x (IP66) electrical system, various lock style closures, pressurized hot melt glue or electrical heat seal closure. For higher speeds, additional upgrades are available such as: a 3 or 4-head rotary carton feeder, extended horizontal carton hoppers, 15' (4.57m) infeed conveyor, and 3-speed drive system.

# FEATURES / SPECIFICATIONS

## WA-SERIES WRAP AROUND CARTONER

### STANDARD FEATURES:

- Continuous motion
- Main drive overload clutch
- Automatic infeed system activated by low product supply to stop infeed system without stopping main machine
- Timing screws or chains for product indexing
- Multi-head rotary carton feeder
- Horizontal powered carton hopper
- Vertical adjustability on carton transfer assemblies
- Powered takeaway belts
- Allen Bradley PLC control system with touch screen
- Captured #60 overhead chains
- 12' (3.66m) long mild steel frame with powder coat paint
- Group lubrication (cluster)
- Overhead lights mounted to center guard beam
- Machine function light tree
- NEMA 12 (IP55) electricals
- 24vdc control voltage
- Gull Wing barrier guarding, electrically interlocked
- Castors for portability and leveling feet

### SEALING OPTIONS:

- Pressurized hot glue system
- Lock style closure

### INFEED OPTIONS:

- 10' (3.05m), or 15' (4.57m) long product infeed conveyors
- 2 or 3-speed drive controls with photo eyes

### OPTIONS:

- Digital readouts for size changes
- Double row pack capability
- Neck thru carton design capability
- Special product indexing and stacking
- Down product sensors
- Extended horizontal powered carton hoppers
- Washdown construction
- Auto oil lube system with timer
- Mechanical deboss or ink jet coder
- Overhead beam operator control panel mounting
- European Model with CE certification and soft metric construction

Features and specifications may differ from model shown.

### STANDARD CARTON BLANK SIZE:

Maximum: 26" (660mm)

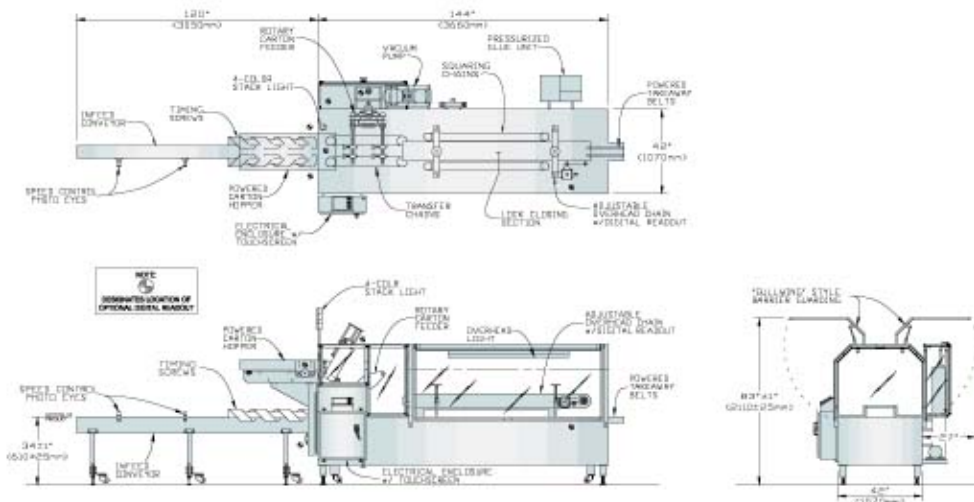

Photo eyes for speed control on the infeed conveyor are used to allow the incoming product supply to smoothly control the machine speed to avoid machine stoppages.



A pneumatic lift-up overhead conveyor on the ADCO WA makes clearing carton jams a simple operation.



Standard overhead lights help to illuminate the ADCO WA-series of machines to help operators get a better view of how the machine is operating.



The ADCO WA-series of cartoners can be equipped with custom product infeed/indexers to provide customers the unique carton/product orientation they are looking for.

### ADCO MANUFACTURING

2170 Academy Avenue  
Sanger, California, U.S.A., 93657

Tel: 559-875-5563

Fax: 559-875-7665

Email: sales@adcomfg.com



### ADCO MANUFACTURING EUROPE

4 Avon Valley Business Park  
St. Annes Road  
St. Annes, Bristol, U.K. BS4 4EE

Tel: +44 (0) 117 972 1555

Fax: +44 (0) 117 972 1881

Email: sales@adcomfg.co.uk



www.adcomfg.com

