



**BALTIMORE AIRCOIL**  
 ONE OF THE  
**Amsted**  
 INDUSTRIES

# SUBMITTAL DATA FORM

	DATE P.O. NO. B.A.C. NO. MODEL NO.	2/1/94 1739 94800442 3130
--	---	------------------------------------

B.A.C. REP:	THE SUNDQUIST COMPANY, INC - INDIANAPOLIS, IN
-------------	---

**SERIES 3000 COOLING TOWER  
EACH UNIT**

**CERTIFIED CAPACITY:** 390 USGPM OF WATER FROM 95 F TO 85 F AT 78 F ENTERING WET BULB

**FAN MOTOR(S):** (1) 5 HP, 1800 RPM, 3 PHASE, 60 HERTZ, 230 VOLTS, STANDARD TEAO ENCLOSURE.

NOTE: Two speed fan motors and/or Energy Miser Fan Systems require a starter that incorporates a 15 second time delay when switching from high to low speed.

6 COPIES OF SUBMITTAL DATA FOR RECORD

FEATURE	FEATURE
AIR INLET SCREENS EXTENDED LUBE LINES EXTRA ACCESS DOOR A19ANC-1 THERMOSTAT & BULB WELL LOOSE	

THANK YOU FOR YOUR ORDER ACCEPTED AT THE B.A.C. PAXTON, IL PLANT ON: JANUARY 28, 1994.

AN APPROVED SUBMITTAL IS NOT REQUIRED. YOUR ORDER IS SCHEDULED TO SHIP FROM OUR PAXTON, IL FACTORY APPROXIMATELY 4/15/94. PLEASE BE PREPARED FOR THE ARRIVAL OF THIS EQUIPMENT, AS OUR FACILITIES CANNOT ACCOMMODATE THE STORAGE OF COMPLETED UNITS.

P.O. BOX 7322, BALTIMORE, MARYLAND 21227 / TELE: (301) 799-6200 / FAX: 301-799-6416  
 P.O. BOX 960, MADERA, CALIFORNIA 93639 / TELE: (209) 673-9231 / FAX: 209-673-5095  
 P.O. BOX 317, PAXTON, ILLINOIS 60957 / TELE: (217) 379-2311 / FAX: 217-379-3522  
 P.O. BOX 402, MILFORD, DELAWARE 19963 / TELE: (302) 422-3061 / FAX: 302-422-9269

**MECHANICAL SPECIFICATIONS**

**BALTIMORE AIRCOIL SERIES 3000 COOLING TOWERS**

**Galvanized Steel Structural Elements**

**B.A.C. SERIAL NUMBER: 94600442**

<b>UNIT TYPE</b>	Factory assembled, induced draft, crossflow cooling tower with vertical air discharge. Principal structural construction is of heavy gauge G210 hot-dip galvanized steel angles and channels.
<b>THERMAL PERFORMANCE</b>	Thermal performance is certified by the Cooling Tower Institute in accordance with CTI Certification Standard STD-201.
<b>CASING</b>	Casing is constructed of fiberglass-reinforced polyester (FRP) panels.
<b>ACCESS</b>	Hinged access doors are provided on the tower for access to fan plenum section. Access doors are constructed of fiberglass-reinforced polyester (FRP) panels with a hot-dip galvanized steel frame.
<b>COLD WATER BASIN</b>	Constructed of heavy gauge hot-dip galvanized steel. Basin includes a depressed center section with drain/clean-out connection.
<b>CONNECTIONS</b>	All connections four inches (4") and larger are both beveled for welding and grooved for Victaulic® mechanical coupling. Connections less than four inches (4") are provided with male pipe thread (MPT).
<b>MAKE-UP FLOAT ASSEMBLY</b>	Bronze make-up valve with unsinkable polystyrene filled plastic float arranged for easy adjustment. The make-up valve is suitable for city water supply pressures between 15 and 50 psig.
<b>STRAINER</b>	Large area, lift out, hot-dip galvanized steel strainer screens are provided. Strainer includes anti-vortexing hood to prevent air entrainment.
<b>AIR INLET LOUVERS</b>	Inlet louvers are wave-formed, fiberglass reinforced polyester (FRP), spaced to minimize air resistance and prevent water splash-out.

**WATER  
DISTRIBUTION  
SYSTEM**

Inlet water enters the high density polyethylene (HDPE) BALANCE CLEAN™ Chamber thru the EASY CONNECT™ Piping Arrangement. The BALANCE CLEAN™ Chamber includes a strainer with perforated openings sized smaller the water distribution nozzle orifices and a plugged blow-down connection to permit purging the BALANCE CLEAN™ Chamber of dirt and debris. It automatically balances water flow to the hot water distribution basins.

Hot water distribution basins are open gravity type constructed of heavy gauge hot-dip galvanized steel with high density polyethylene (HDPE) water inlet diffusers and hot water basin covers. Polypropylene metering orifices are provided to assure even distribution of water over the wet deck surface.

**BALTIDRIVE®  
PowerTrain FAN  
DRIVE SYSTEM**

Fan is driven by a one-piece, multi-groove, solid back, neoprene/polyester belt designed specifically for cooling tower service. Belt tension is adjusted by a threaded bolt-and-nut arrangement. Fan sheave is cast aluminum and motor sheave is protected from moist discharge air by a high density polyethylene (HDPE) vented enclosure.

**FAN SHAFTS AND  
BEARINGS**

Fan and fan shaft are supported by heavy duty, self-aligning, grease packed, relubricatable ball bearings with special seals for protection against dust and moisture, and integral slinger rings. All bearings are designed for minimum L<sub>10</sub> life of 40,000 hours.

**FAN AND FAN  
CYLINDER**

Fan(s) are heavy duty, axial flow type with aluminum alloy blades. The heavy gauge, hot-dip galvanized fan cylinder(s) are designed for streamlined air entry and minimum tip clearances for maximum fan efficiency.

**FAN GUARD**

A heavy gauge, hot-dip galvanized wire fan guard is provided over each fan cylinder.

**MOTOR**

Fan motor is totally enclosed, air-over (TEAO), reversible squirrel cage, ball bearing type, designed specifically for cooling tower service. Motor is furnished with special moisture protection on windings, shafts and bearings.

**BACross® WET  
DECK SURFACE  
AND DRIFT  
ELIMINATORS**

The wet deck surface and integral drift eliminators are formed from polyvinyl chloride (PVC). They are impervious to rot, decay, fungus or biological attack, and have a flame spread rating of 5 per ASTM Standard E84-77a. The eliminators are designed to effectively strip entrained moisture from the leaving airstream with a minimum of air resistance. This wet deck is suitable for a maximum entering water temperature of 120°F.

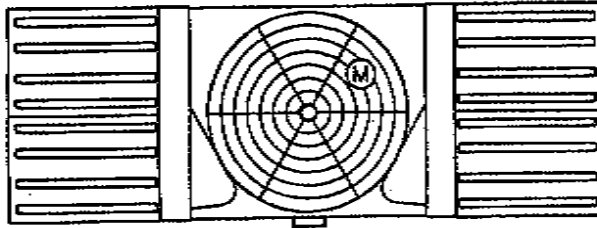

PLAN VIEW

(M) MOTOR LOCATION

MODEL NUMBER	SHIPPING WEIGHT	OPERATING WEIGHT	H	A	B
3130	4140	10450	8'-10"	9'-0"	2'-6 5/8"
3150	4170	10480	8'-10"	9'-0"	2'-6 5/8"
3165	4180	10490	8'-10"	9'-0"	2'-6 5/8"
3184	4250	10560	8'-10"	9'-0"	2'-6 5/8"
3185	4510	10830	10'-2"	8'-9 3/16"	2'-9"
3205	4580	10900	10'-2"	8'-9 3/16"	2'-9"

NOTES:

1. CONNECTIONS 3" & SMALLER ARE MPT. CONNECTIONS 4" & LARGER ARE GROOVED TO SUIT A MECHANICAL COUPLING AND BEVELED FOR WELDING.
2. ALL DIMENSIONS ARE IN FEET AND INCHES. WEIGHTS ARE IN POUNDS.
3. FOR WEIGHT LOADING AND STANDARD SUGGESTED STEEL SUPPORT REFER TO DRAWING BAC-14012A (PLAN A) OR BAC-14044A (PLAN B). FOR UNITS BEING INSTALLED ON VIBRATION ISOLATORS SUPPLIED BY BALTIMORE AIRCOIL COMPANY, REFER TO DRAWING BAC-140818.
4. THE AREA ABOVE THE DISCHARGE OF THE FAN MUST BE UNOBSTRUCTED.
5. FOR WATER INLET AND OUTLET SIZES AND LOCATIONS REFER TO DRAWING BAC-14016A FOR MODELS 3130 THRU 3184 AND DRAWING BAC-14155A FOR MODELS 3185 & 3205.

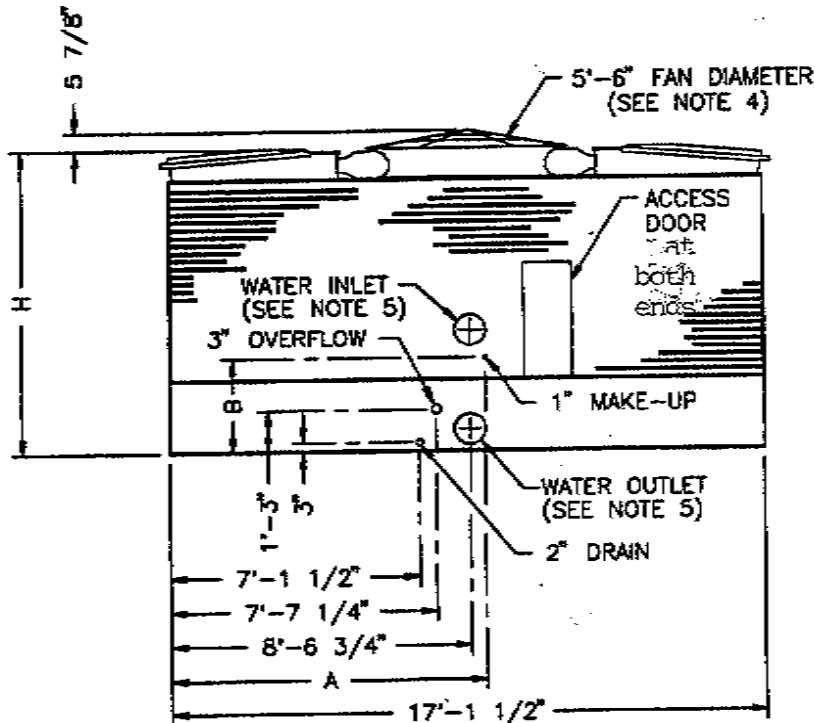

END ELEVATION

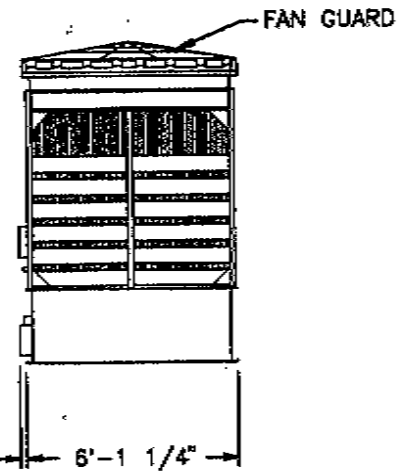

SIDE ELEVATION

SERIES 3000 WITH END OUTLET

B.A.C.  
ORDER NO: 94600442  
DATE: 1/28/94



BALTIMORE AIRCOIL  
COMPANY

MODEL:  
COOLING TOWER  
DRAWING NUMBER:  
BAC-14000A

B

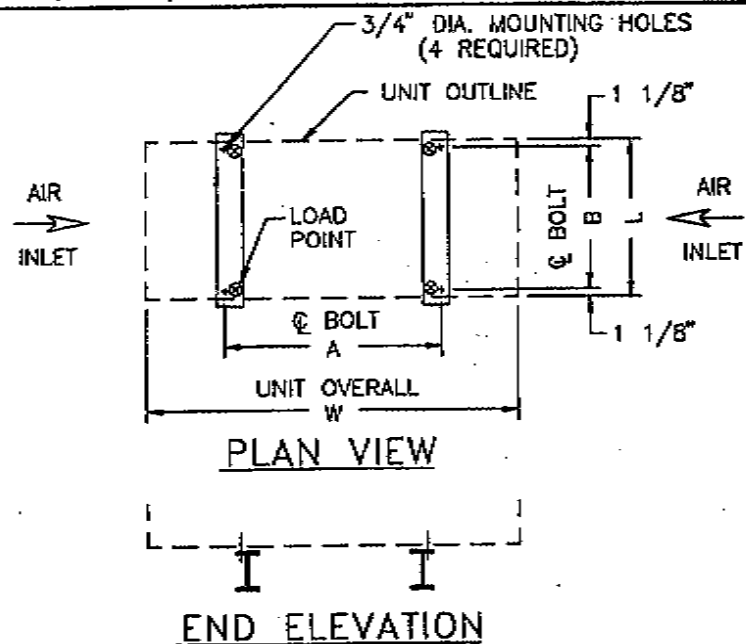

MODEL NO.	SHIPPING WEIGHT (LBS)	OPERATING WEIGHT (LBS)	WEIGHT AT $\otimes$ (LBS)	DIMENSIONS			
				L	W	A	B
3130	4140	10450	2613	6'-1 1/4"	17'-1 1/2"	8'-0"	5'-11"
<del>3150</del>	<del>4170</del>	<del>10480</del>	<del>2620</del>	<del>6'-1 1/4"</del>	<del>17'-1 1/2"</del>	<del>8'-0"</del>	<del>5'-11"</del>
3165	4180	10490	2623	6'-1 1/4"	17'-1 1/2"	8'-0"	5'-11"
3184	4250	10560	2640	6'-1 1/4"	17'-1 1/2"	8'-0"	5'-11"
3185	4510	10830	2708	6'-1 1/4"	17'-1 1/2"	8'-0"	5'-11"
3205	4580	10900	2725	6'-1 1/4"	17'-1 1/2"	8'-0"	5'-11"
3213	5460	14040	3510	7'-9 5/8"	18'-0 1/2"	8'-0"	7'-7 3/8"
3235	5470	14050	3513	7'-9 5/8"	18'-0 1/2"	8'-0"	7'-7 3/8"
3269	5540	14120	3530	7'-9 5/8"	18'-0 1/2"	8'-0"	7'-7 3/8"
3294	5560	14140	3535	7'-9 5/8"	18'-0 1/2"	8'-0"	7'-7 3/8"
3315	5610	14190	3548	7'-9 5/8"	18'-0 1/2"	8'-0"	7'-7 3/8"
3341	7080	19010	4753	9'-9 1/4"	20'-0 1/2"	8'-0"	9'-7"
3373	7100	19030	4758	9'-9 1/4"	20'-0 1/2"	8'-0"	9'-7"
3400	7150	19080	4770	9'-9 1/4"	20'-0 1/2"	8'-0"	9'-7"
3424	7170	19100	4775	9'-9 1/4"	20'-0 1/2"	8'-0"	9'-7"
3427	8410	25670	6418	11'-9 3/4"	20'-6 1/2"	9'-6"	11'-7 1/2"
3458	8460	25720	6430	11'-9 3/4"	20'-6 1/2"	9'-6"	11'-7 1/2"
3485	8480	25740	6435	11'-9 3/4"	20'-6 1/2"	9'-6"	11'-7 1/2"
3514	9170	26430	6608	11'-9 3/4"	20'-6 1/2"	9'-6"	11'-7 1/2"
3550	9430	26690	6673	11'-9 3/4"	20'-6 1/2"	9'-6"	11'-7 1/2"

**NOTES:**

1. SUPPORTING STEELWORK AND ANCHOR BOLTS TO BE DESIGNED AND FURNISHED BY OTHERS.
2. ALL SUPPORTING STEEL MUST BE LEVEL AT TOP.
3. BEAMS SHOULD BE SELECTED IN ACCORDANCE WITH ACCEPTED STRUCTURAL PRACTICE, MAXIMUM DEFLECTION OF BEAM UNDER UNIT TO BE 1/360 OF SPAN, NOT TO EXCEED 1/2 INCH.
4. ALTERNATELY THE TOWER MAY BE SUPPORTED ON COLUMNS AT THE FOUR ANCHOR BOLT LOCATIONS SHOWN. COLUMNS MUST PROVIDE A MINIMUM OF 6" X 6" BEARING SURFACE UNDER EACH OF THE CONCENTRATED LOAD POINTS.
5. IF VIBRATION ISOLATION RAILS ARE USED BETWEEN TOWER AND SUPPORTING STEEL, BE CERTAIN TO ALLOW FOR THE LENGTH OF THE VIBRATION RAILS WHEN DETERMINING LENGTH OF SUPPORTING STEEL. VIBRATION RAIL LENGTH AND MOUNTING HOLE LOCATIONS MAY DIFFER FROM THOSE OF THE COOLING TOWER. REFER TO VIBRATION ISOLATOR DRAWINGS FOR THIS DATA.
6. OPERATING WEIGHT AND WEIGHT LOADING ARE FOR TOWER WITH WATER LEVEL IN PAN AT OVERFLOW.

B.A.C.  
ORDER NO: 94600442

DATE: 1/28/94



BALTIMORE AIRCOIL  
COMPANY

MODEL:  
SUGGESTED SUPPORT  
LOCATION - PLAN A

DRAWING NUMBER:  
BAC-14012A

A

**NOTES:**

1. ALL CONDUIT MUST BE WATER TIGHT AND PITCHED DOWNWARD TO ALLOW CONDENSATION TO DRAIN AWAY FROM MOTOR CONDUIT BOX. THEREFORE, DO NOT RUN THE CONDUIT THROUGH FAN DECK.
2. ALL WIRING MUST CONFORM TO LOCAL AND NATIONAL ELECTRICAL CODES.
3. RIGID CONDUIT OUTSIDE CASING PANEL MUST TURN DOWN TO JUNCTION BOX.

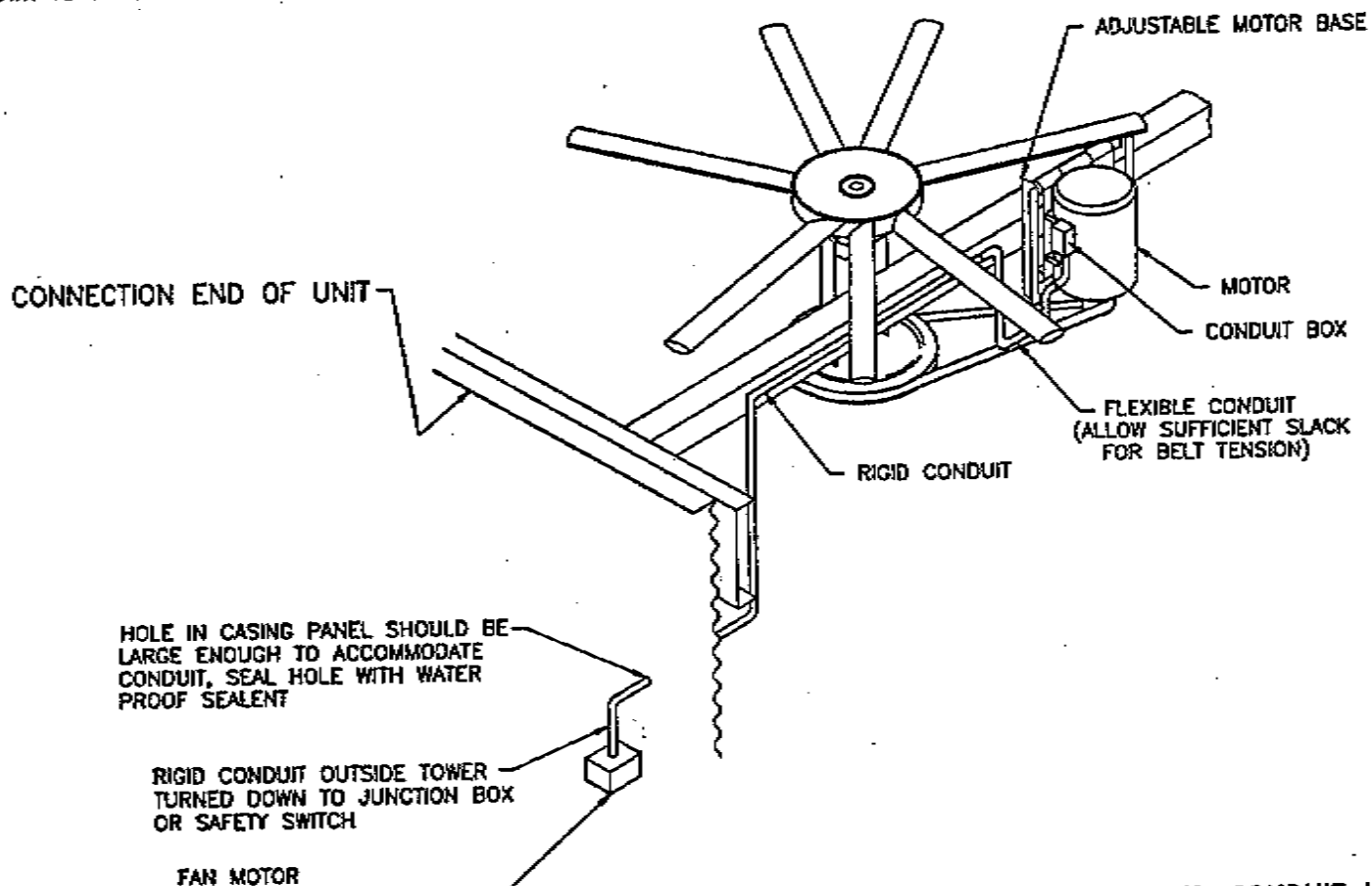

**RECOMMENDED CONDUIT INSTALLATION FOR UNITS WITH STANDARD MOTOR**

DISCONNECT/SAFETY SWITCH IN WEATHER PROOF ENCLOSURE MUST BE RATED FOR PROPER VOLTAGE AND HORSEPOWER OF

B.A.C. ORDER NO: 94600442	 BALTIMORE AIRCOIL COMPANY	MODEL: COOLING TOWER	
DATE: 1/28/94		DRAWING NUMBER: BAC-14203A	

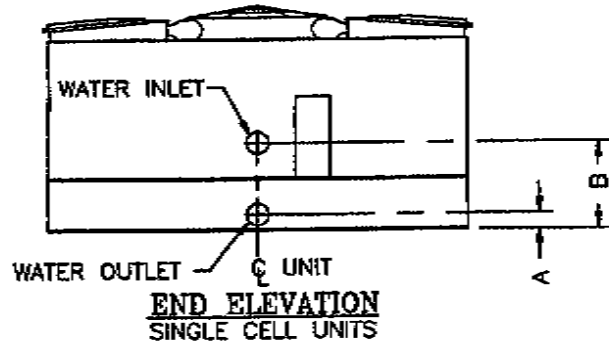

**TABLE 1. MAXIMUM FLOW RATE PER UNIT (USGPM)**

OUTLET CONFIGURATION	3130 THRU 3184		3213 THRU 3315	
	PUMP SUCTION	GRAVITY FLOW	PUMP SUCTION	GRAVITY FLOW
SINGLE CELL UNIT WITH ONE END OUTLET	1130	1130	1820	1200
TWO CELL UNIT WITH ONE END OUTLET	2260	1200	2600	1200
TWO CELL UNIT WITH TWO END OUTLETS	2260	2260	3640	2400

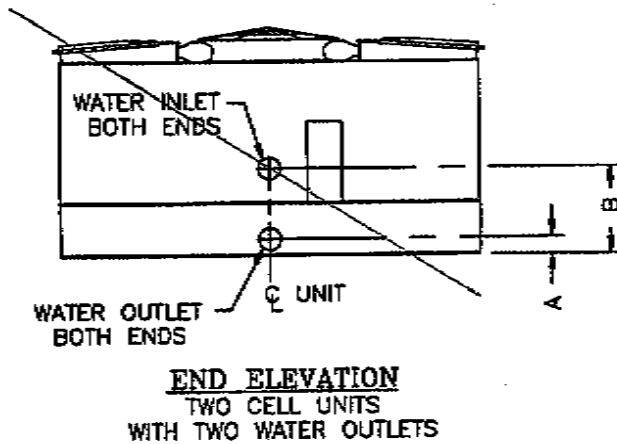
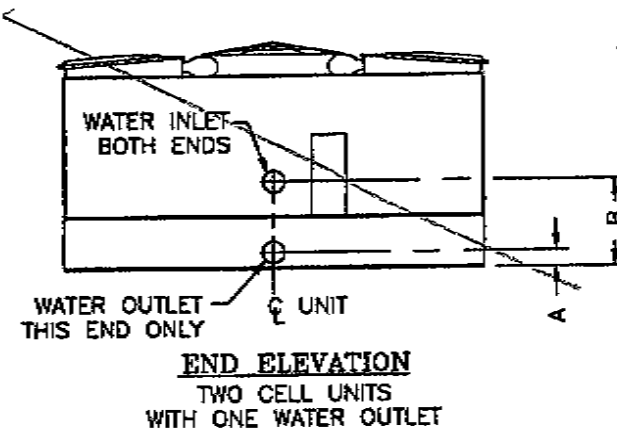

**TABLE 2. MAXIMUM FLOW RATE PER WATER OUTLET CONNECTION (USGPM)**

CONN. SIZE (IN.)	PUMP SUCTION	GRAVITY FLOW	A
6	750	200	7 1/16
8	1300	550	8 1/16
10	2300	800	9 1/8
12	2600	1050	10 1/8
14	N/A	1200	10 3/4

**TABLE 3. MAXIMUM FLOW RATE PER WATER INLET CONNECTION (USGPM). ONE WATER INLET REQUIRED PER CELL**

CONN. SIZE (IN.)	MAX. FLOW RATE PER CONNECTION	B	
		3130 THRU 3184	3213 THRU 3315
6	750	3'-0 1/8"	3'-6 9/16"
8	1300	3'-1 1/8"	3'-7 9/16"
10	1820	N/A	3'-8 9/16"



**NOTES:**

- DO NOT SUPPORT PIPING FROM COOLING TOWER. ALL NECESSARY PIPING SUPPORTS TO BE SUPPLIED BY OTHERS.
- FIELD PIPING SHOULD BE FABRICATED AT TIME OF UNIT INSTALLATION. PRE-FABRICATION OF PIPE WORK IS NOT RECOMMENDED.
- FLOW RATES ARE GIVEN FOR BOTH PUMP SUCTION AND GRAVITY FLOW APPLICATIONS. THEY ARE BASED ON THE MAXIMUM HEAD AVAILABLE TO MOVE WATER FROM THE BASIN INTO THE OUTLET PIPING.
- WATER INLET AND OUTLET CONNECTIONS ARE GROOVED TO SUIT A MECHANICAL COUPLING AND BEVELED FOR WELDING.
- ALL PUMP SUCTION CONFIGURATIONS ARE FURNISHED WITH STRAINERS AND ANTI-VORTEXING DEVICES.

**SERIES 3000 WITH END WATER OUTLET**

B.A.C.  
ORDER NO: 94600442  
DATE: 1/28/94



**BALTIMORE AIRCOIL  
COMPANY**

MODEL:  
COOLING TOWER  
DRAWING NUMBER:  
BAC-14016A