



ISO 9001
COMPANY

PRODUCT REPORT

PRD 29/03

VXMC Evaporative Condenser

10' Wide Models Provide *The Perfect Fit* for Tight Spaces



Ideal for replacement opportunities, the VXMC Evaporative Condenser provides reliable, efficient operation for units in tight spaces. The nominal 10' wide VXMCs complement the layout flexibility of BAC's Series V (VC2) Evaporative Condenser product line.

Similar to the VC2 Evaporative Condenser, the VXMC is an axial fan forced draft evaporative condenser designed to ensure dependable performance, long life, and ease of maintenance. All major components are designed, tested, and manufactured by BAC ensuring high quality construction and long life. In recognition of BAC's excellence in engineering design and manufacturing quality, BAC has been awarded the certificate of approval for compliance with ISO-9001.

The ability to locate compact VXMC Evaporative Condensers in tight locations allows design engineers to better utilize available space. Units can be placed close to walls or in narrow set-backs due to the single side air entry design. This design also permits compact multiple unit installations in either close back-to-back or side-by-side arrangements.

A variety of sizes and capacities can be found in the following pages. Please consult your local BAC Sales Representative for more details.

Selection Data

Selection Procedure (Heat Rejection Method):

The Base Heat Rejection for each condenser is given in the Engineering Data table on the next page. Tables 1 and 2 below present the correction factors to be applied to the system's heat rejection for various condensing temperatures, wet bulb temperatures, and refrigerants. To select a model, perform the following steps:

1. Establish the total heat rejection required for the system in thousands of Btu per hour (MBH).
 $\text{Total Heat Rejection} = \text{compressor evaporator capacity (MBH)} + \text{compressor BHP} \times 2.545$
2. Determine the refrigerant and design conditions for condensing and wet bulb temperatures.
3. Using the appropriate table for the system refrigerant (Table 1 or 2), determine the correction factor for the design condensing and wet bulb temperature.
4. Multiply the total heat rejection found in Step 1 by the correction factor determined in Step 3.
5. Using the "Base Heat Rejection" column given in the Engineering Data table, select an evaporative condenser that meets or exceeds the corrected heat rejection calculated in Step 4.

Table 1 Heat Rejection Capacity Factors – R-22, R-134a

| Condensing Pressure (PSIG) | | Cond. Temp. (°F) | Entering Wet Bulb Temperature (°F) | | | | | | | | | | | | | | | | |
|----------------------------|--------|------------------|------------------------------------|------|------|------|------|------|------|------|------|------|------|------|------|------|------|------|------|
| R-22 | R-134a | | 50 | 52 | 54 | 56 | 58 | 60 | 62 | 64 | 66 | 68 | 70 | 72 | 74 | 76 | 78 | 80 | 82 |
| 155.7 | 95.2 | 85 | 1.09 | 1.14 | 1.19 | 1.25 | 1.32 | 1.40 | 1.49 | 1.60 | 1.74 | 1.91 | 2.12 | 2.40 | 2.78 | 3.33 | - | - | - |
| 168.4 | 104.3 | 90 | 0.93 | 0.96 | 1.00 | 1.04 | 1.09 | 1.14 | 1.20 | 1.27 | 1.35 | 1.44 | 1.56 | 1.70 | 1.87 | 2.10 | 2.40 | 2.82 | 3.46 |
| 171.0 | 106.2 | 91 | 0.90 | 0.93 | 0.97 | 1.01 | 1.05 | 1.10 | 1.15 | 1.21 | 1.29 | 1.37 | 1.47 | 1.60 | 1.75 | 1.95 | 2.20 | 2.55 | 3.06 |
| 173.7 | 108.1 | 92 | 0.88 | 0.91 | 0.94 | 0.97 | 1.01 | 1.06 | 1.11 | 1.16 | 1.23 | 1.31 | 1.40 | 1.51 | 1.65 | 1.82 | 2.04 | 2.33 | 2.74 |
| 176.4 | 110.0 | 93 | 0.85 | 0.88 | 0.91 | 0.94 | 0.98 | 1.02 | 1.07 | 1.12 | 1.18 | 1.25 | 1.33 | 1.43 | 1.56 | 1.71 | 1.90 | 2.14 | 2.49 |
| 179.1 | 111.9 | 94 | 0.83 | 0.85 | 0.88 | 0.91 | 0.95 | 0.98 | 1.03 | 1.08 | 1.13 | 1.20 | 1.27 | 1.35 | 1.47 | 1.60 | 1.77 | 1.98 | 2.27 |
| 181.8 | 113.9 | 95 | 0.81 | 0.83 | 0.86 | 0.88 | 0.92 | 0.95 | 0.99 | 1.04 | 1.09 | 1.15 | 1.22 | 1.30 | 1.40 | 1.51 | 1.66 | 1.84 | 2.09 |
| 184.6 | 115.9 | 96.3 | 0.79 | 0.81 | 0.83 | 0.86 | 0.89 | 0.92 | 0.96 | 1.00 | 1.05 | 1.10 | 1.17 | 1.24 | 1.33 | 1.43 | 1.56 | 1.72 | 1.93 |
| 187.4 | 117.5 | 97 | 0.76 | 0.79 | 0.81 | 0.83 | 0.86 | 0.89 | 0.93 | 0.97 | 1.01 | 1.06 | 1.12 | 1.18 | 1.26 | 1.36 | 1.47 | 1.61 | 1.80 |
| 190.2 | 119.9 | 98 | 0.75 | 0.76 | 0.79 | 0.81 | 0.84 | 0.86 | 0.90 | 0.93 | 0.97 | 1.02 | 1.07 | 1.13 | 1.21 | 1.29 | 1.39 | 1.52 | 1.68 |
| 193.0 | 122.1 | 99 | 0.73 | 0.74 | 0.77 | 0.79 | 0.81 | 0.84 | 0.87 | 0.90 | 0.94 | 0.98 | 1.03 | 1.09 | 1.15 | 1.23 | 1.32 | 1.43 | 1.57 |
| 195.9 | 124.1 | 100 | 0.71 | 0.73 | 0.74 | 0.77 | 0.79 | 0.81 | 0.84 | 0.87 | 0.91 | 0.95 | 0.99 | 1.04 | 1.10 | 1.17 | 1.26 | 1.36 | 1.48 |
| 210.7 | 149.6 | 105 | 0.63 | 0.64 | 0.66 | 0.67 | 0.69 | 0.71 | 0.73 | 0.75 | 0.77 | 0.80 | 0.83 | 0.87 | 0.91 | 0.95 | 1.00 | 1.07 | 1.14 |
| 226.4 | 146.4 | 110 | 0.56 | 0.57 | 0.58 | 0.60 | 0.61 | 0.62 | 0.64 | 0.65 | 0.67 | 0.69 | 0.71 | 0.74 | 0.77 | 0.80 | 0.83 | 0.87 | 0.92 |

Table 2 Heat Rejection Factors – R-717

| Condensing Pressure (PSIG) | | Cond. Temp. (°F) | Entering Wet Bulb Temperature (°F) | | | | | | | | | | | | | | | | |
|----------------------------|------|------------------|------------------------------------|------|------|------|------|------|------|------|------|------|------|------|------|------|------|------|----|
| R-717 | | | 50 | 52 | 54 | 56 | 58 | 60 | 62 | 64 | 66 | 68 | 70 | 72 | 74 | 76 | 78 | 80 | 82 |
| 151.7 | 85 | 0.97 | 1.01 | 1.06 | 1.11 | 1.17 | 1.25 | 1.33 | 1.43 | 1.55 | 1.70 | 1.89 | 2.14 | 2.47 | 2.97 | - | - | - | |
| 165.9 | 90 | 0.83 | 0.86 | 0.89 | 0.93 | 0.97 | 1.01 | 1.07 | 1.13 | 1.20 | 1.28 | 1.38 | 1.51 | 1.67 | 1.87 | 2.13 | 2.51 | 3.08 | |
| 168.9 | 91 | 0.80 | 0.83 | 0.86 | 0.90 | 0.93 | 0.98 | 1.02 | 1.08 | 1.14 | 1.22 | 1.31 | 1.42 | 1.56 | 1.73 | 1.96 | 2.27 | 2.72 | |
| 171.9 | 92 | 0.78 | 0.81 | 0.83 | 0.87 | 0.90 | 0.94 | 0.99 | 1.04 | 1.10 | 1.17 | 1.25 | 1.35 | 1.47 | 1.62 | 1.82 | 2.08 | 2.44 | |
| 174.9 | 93 | 0.76 | 0.78 | 0.81 | 0.84 | 0.87 | 0.91 | 0.95 | 1.00 | 1.05 | 1.11 | 1.19 | 1.28 | 1.38 | 1.52 | 1.69 | 1.91 | 2.21 | |
| 178.0 | 94 | 0.74 | 0.76 | 0.79 | 0.81 | 0.84 | 0.88 | 0.92 | 0.96 | 1.01 | 1.07 | 1.13 | 1.21 | 1.31 | 1.43 | 1.58 | 1.77 | 2.02 | |
| 181.1 | 95 | 0.72 | 0.74 | 0.76 | 0.79 | 0.82 | 0.85 | 0.88 | 0.92 | 0.97 | 1.02 | 1.08 | 1.16 | 1.24 | 1.35 | 1.48 | 1.64 | 1.86 | |
| 185.0 | 96.3 | 0.69 | 0.71 | 0.73 | 0.76 | 0.78 | 0.81 | 0.84 | 0.88 | 0.92 | 0.97 | 1.02 | 1.09 | 1.16 | 1.25 | 1.36 | 1.50 | 1.68 | |
| 187.4 | 97 | 0.68 | 0.70 | 0.72 | 0.74 | 0.77 | 0.79 | 0.83 | 0.86 | 0.90 | 0.94 | 0.99 | 1.05 | 1.13 | 1.21 | 1.31 | 1.44 | 1.60 | |
| 190.6 | 98 | 0.66 | 0.68 | 0.70 | 0.72 | 0.74 | 0.77 | 0.80 | 0.83 | 0.87 | 0.91 | 0.96 | 1.01 | 1.07 | 1.15 | 1.24 | 1.35 | 1.49 | |
| 193.9 | 99 | 0.65 | 0.66 | 0.68 | 0.70 | 0.72 | 0.75 | 0.77 | 0.80 | 0.84 | 0.87 | 0.92 | 0.97 | 1.03 | 1.10 | 1.18 | 1.28 | 1.40 | |
| 197.2 | 100 | 0.63 | 0.65 | 0.66 | 0.68 | 0.70 | 0.72 | 0.75 | 0.78 | 0.81 | 0.84 | 0.88 | 0.93 | 0.98 | 1.05 | 1.12 | 1.21 | 1.32 | |
| 214.2 | 105 | 0.56 | 0.57 | 0.58 | 0.60 | 0.61 | 0.63 | 0.65 | 0.67 | 0.69 | 0.71 | 0.74 | 0.77 | 0.81 | 0.85 | 0.89 | 0.95 | 1.01 | |
| 232.3 | 110 | 0.50 | 0.51 | 0.52 | 0.53 | 0.54 | 0.55 | 0.57 | 0.58 | 0.60 | 0.62 | 0.64 | 0.66 | 0.68 | 0.71 | 0.74 | 0.78 | 0.82 | |

NOTE: Consult your BAC Representative for evaporative condenser selections for systems utilizing refrigerants other than R-717, R-22, or R-134a and systems requiring special considerations, such as water-cooled screw compressors, evaporative condensers with ammonia desuperheaters, or halocarbon subcooling coils.

Engineering Application

Refer to the BAC *Evaporative Condenser Engineering Manual* and the BAC *Operating and Maintenance Instructions* for details concerning Evaporative Condenser application, operation and maintenance.

Engineering Data

**Do not use for construction.
Refer to factory certified dimensions.**

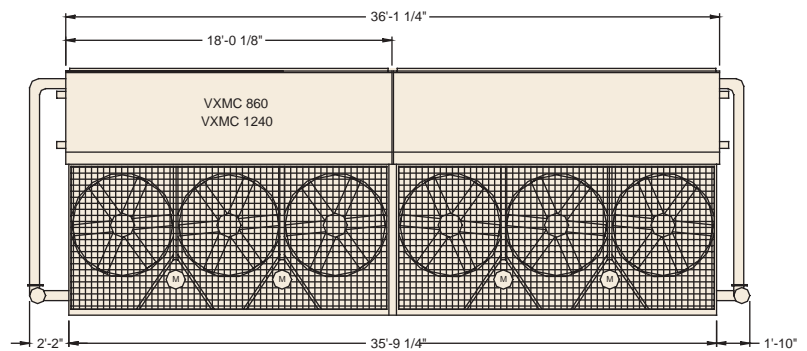
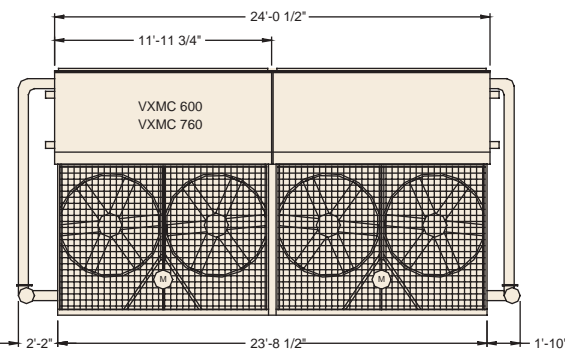
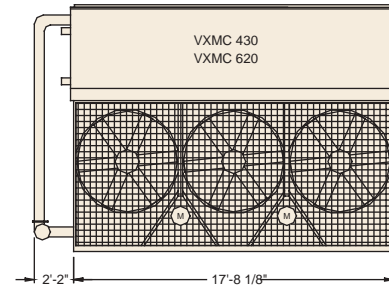
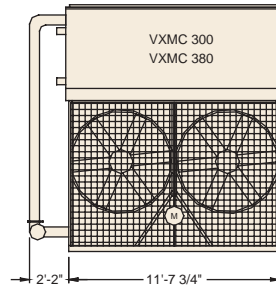
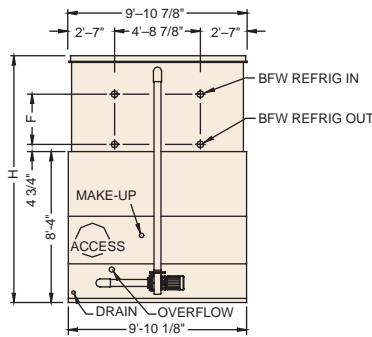

| Model Number | Base Heat Rejection (MBH) | Nom. R-717 Tons | Approx. Shpg. Weight (lbs) | Approx. Oper. Weight (lbs) | Heaviest Section (Coil) (lbs) | CFM | Fan Motor HP (0" ESP) | GPM | Pump Motor HP | R-717 Charge (lbs) | Remote Sump | | F (in) | H (in) |
|--------------|---------------------------|-----------------|----------------------------|----------------------------|-------------------------------|---------|-----------------------|-------|---------------|--------------------|------------------------|----------------------------|--------|---------|
| | | | | | | | | | | | Bottom Drain Size (in) | Approx. Oper. Weight (lbs) | | |
| VXMC-300 | 4,410 | 213 | 14,420 | 18,950 | 9,760 | 59,800 | 10 | 490 | 5 | 380 | 8 | 15,680 | 37 3/4 | 157 7/8 |
| VXMC-340 | 4,998 | 241 | 16,280 | 20,900 | 11,580 | 55,400 | 10 | 490 | 5 | 460 | 8 | 17,630 | 48 1/4 | 168 3/8 |
| VXMC-380 | 5,586 | 270 | 18,180 | 22,870 | 13,400 | 59,400 | 15 | 490 | 5 | 550 | 8 | 19,600 | 58 3/4 | 178 7/8 |
| VXMC-430 | 6,321 | 305 | 20,370 | 27,120 | 14,750 | 80,700 | 5 & 7 1/2 | 740 | 5 | 560 | 10 | 22,600 | 37 3/4 | 157 7/8 |
| VXMC-460 | 6,762 | 326 | 22,920 | 27,360 | 15,010 | 87,700 | 5 & 10 | 740 | 5 | 590 | 10 | 22,840 | 37 3/4 | 157 7/8 |
| VXMC-510 | 7,497 | 362 | 23,080 | 29,960 | 17,430 | 87,200 | 5 & 10 | 740 | 5 | 700 | 10 | 25,440 | 48 1/4 | 168 3/8 |
| VXMC-560 | 8,232 | 397 | 23,360 | 30,220 | 17,710 | 95,700 | 7 1/2 & 15 | 740 | 5 | 750 | 10 | 25,700 | 48 1/4 | 168 3/4 |
| VXMC-585 | 8,600 | 415 | 25,980 | 32,970 | 20,230 | 93,600 | 7 1/2 & 15 | 740 | 5 | 830 | 10 | 28,460 | 58 3/4 | 178 7/8 |
| VXMC-620 | 9,114 | 440 | 26,280 | 33,250 | 20,530 | 100,500 | 10 & 20 | 740 | 5 | 860 | 10 | 28,740 | 58 3/4 | 178 7/8 |
| VXMC-600 | 8,820 | 426 | 28,840 | 37,900 | 9,760 | 119,600 | (2) 10 | 980 | (2) 5 | 760 | 10 | 31,360 | 37 3/4 | 157 7/8 |
| VXMC-680 | 9,996 | 482 | 32,560 | 41,800 | 11,580 | 110,800 | (2) 10 | 980 | (2) 5 | 920 | 10 | 35,260 | 48 1/4 | 168 3/4 |
| VXMC-760 | 11,172 | 539 | 36,360 | 45,740 | 13,400 | 118,800 | (2) 15 | 980 | (2) 5 | 1,100 | 10 | 39,200 | 58 3/4 | 178 7/8 |
| VXMC-860 | 12,642 | 610 | 44,740 | 54,240 | 15,240* | 161,400 | (2) 5 & (2) 7 1/2 | 1,480 | (2) 5 | 1,120 | 12 | 45,200 | 37 3/4 | 157 7/8 |
| VXMC-920 | 13,524 | 652 | 45,840 | 54,720 | 15,820* | 175,400 | (2) 5 & (2) 10 | 1,480 | (2) 5 | 1,180 | 12 | 45,680 | 37 3/4 | 157 7/8 |
| VXMC-1020 | 14,994 | 723 | 46,160 | 59,920 | 17,430 | 174,400 | (2) 5 & (2) 10 | 1,480 | (2) 5 | 1,400 | 12 | 50,880 | 48 1/4 | 168 3/8 |
| VXMC-1120 | 16,464 | 794 | 46,720 | 60,440 | 17,710 | 191,400 | (2) 7 1/2 & (2) 15 | 1,480 | (2) 5 | 1,500 | 12 | 51,400 | 48 1/4 | 168 3/8 |
| VXMC-1170 | 17,199 | 830 | 51,960 | 65,940 | 20,230 | 187,200 | (2) 7 1/2 & (2) 15 | 1,480 | (2) 5 | 1,660 | 12 | 56,920 | 58 3/4 | 178 7/8 |
| VXMC-1240 | 18,228 | 879 | 52,560 | 66,500 | 20,530 | 201,000 | (2) 10 & (2) 20 | 1,480 | (2) 5 | 1,720 | 12 | 57,480 | 58 3/4 | 178 7/8 |

NOTES:

1. Model number denotes nominal tons using R-22 at 105°F cond. temp., 40°F suct. temp., 78°F wet bulb.
2. Nominal R-717 tons are at 96.3°F cond. temp., 20°F suct. temp., and 78°F wet bulb.
3. Standard refrigerant connection sizes are 4-inch BFW inlet and outlet. Other connections sizes are available on special order.
4. Operating weight shown in the table is based on total unit weight, weight of refrigerant operating charge, and basin filled to overflow level.
5. The R-22 operating charge is 1.93 times the R-717 charge; R-134a is 1.98 times.

* PAN SECTION IS HEAVIEST SECTION

Construction Details

Coil Section

The coil section consists of the condensing coils, the water distribution system, and the drift eliminators enclosed in a heavy-gauge, G-235 (Z700 metric) hot-dip galvanized steel casing.

The condensing coil is all prime surface continuous serpentine steel tubing that is tested with air to 375 psig (2687 kPa) under water. The coil is designed for low pressure drop with sloping tubes for free drainage of the condensed refrigerant. The coil is encased in a steel framework and the entire assembly is hot-dip galvanized after fabrication (HDGAF).

The water distribution system consists of a galvanized header and schedule 40 PVC spray branches with large diameter, non-clog, plastic spray nozzles oriented for optimum wetting of the coil under all operating conditions. The nozzles, spray branches, and headers are connected by rubber grommets, which permit easy removal for cleaning.

Drift eliminators provide a minimum of three changes in air direction with an air deceleration zone to limit drift loss to less than 0.002% of the total water circulated while directing the discharge air away from the fans.

Pan Section

The pan section is a combination pan and fan arrangement with the fans in a blow-through configuration. All structural elements and steel panels are constructed of heavy-gauge, G-235 (Z700 metric) hot-dip galvanized steel.

Two-stage, axial-flow fans are mounted in series within a close-fitting cylinder having a smooth contoured inlet ring and intermediate guide vanes to maximize fan efficiency. Each fan operates at one-half the total static pressure, allowing for lower fan speeds and quieter operation than single stage fans.

Fan drives are one-piece, multi-groove, banded belts. Drives are designed for not less than 150% of motor nameplate horsepower and are adjustable by means of a single threaded, single-point arrangement accessible from outside the fan assembly. Standard fan motors are a totally enclosed fan cooled (TEFC) design with a 1.15 service factor.

Fan bearings are heavy-duty pillow-block type, grease-packed ball bearings with cast iron bodies, eccentric locking collars, and easily accessible grease fittings.

The water pump is a close-coupled, bronze-fitted, centrifugal pump with a mechanical seal. It is factory mounted and completely piped from the suction strainer to the water distribution system.

A water bleed line, with metering valve to control the bleed rate, is installed between the pump discharge and the overflow connection.

Support

The recommended support arrangement for the VXMC consists of two I-beams running the full length of the unit on nominal 10' wide centers. The steel support beam must be located directly beneath the unit and extend the full length of the pan section.

Beam size should be calculated to accordance with accepted structural practices. Use 65% of the operating weight as a uniform load on each beam. The length of the beam must be equal to the length of the pan. The maximum permissible beam deflection and centerline distances between boltholes are tabulated below.

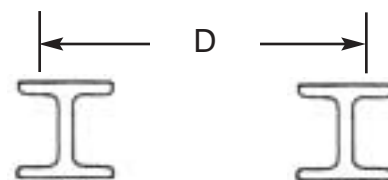

| Model Number | D (in) | Maximum Deflection (in) |
|---------------|---------|-------------------------|
| VXMC-300-380 | 115 1/2 | 3/8 |
| VXMC-430-1240 | 115 1/2 | 1/2 |

SAFETY

Adequate precautions, appropriate for the installation and location of these products, should be taken to safeguard the public from possible injury and the equipment and the premises from damage. Operation, maintenance, and repair of this equipment should be undertaken only by personnel qualified to do so. Proper care, procedures and tools must be used in handling, lifting, installing, operating, maintaining, and repairing this equipment to prevent personal injury and/or property damage.

| NO. | REVISION | DATE |
|-----|-----------------|---------|
| 1 | CHG TO LH ARRAY | 7/24/86 |

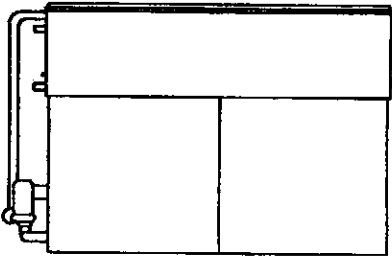
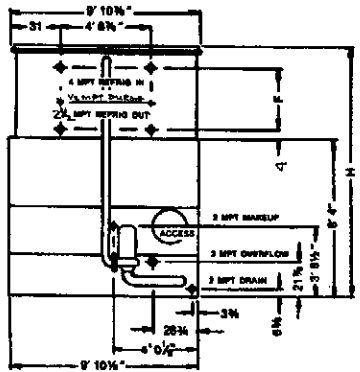

(M) Fan motor location.

| MODEL NO. | APPROX. SHIPPING WEIGHT | APPROX. OPERATING WEIGHT | F | H |
|-----------|-------------------------|--------------------------|-----|-------------|
| VXMC 400 | 20670 | 27400 | 37% | 13'-1 1/2" |
| VXMC 400 | 22820 | 27300 | 37% | 13'-1 1/2" |
| VXMC 510 | 20000 | 28900 | 48% | 14'-0 1/2" |
| VXMC 580 | 23360 | 30220 | 49 | 14'-0 3/4" |
| VXMC 585 | 25000 | 32970 | 50% | 14'-10 1/2" |
| VXMC 620 | 28600 | 38250 | 50% | 14'-10 1/2" |

SUGGESTED SUPPORT DETAILS

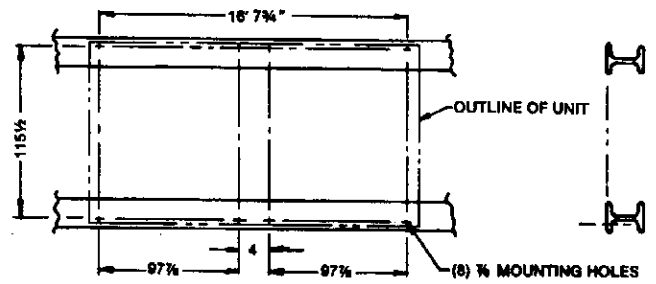

- NOTES:**
- The recommended support arrangement for VX units consists of two parallel I-beams extending the full length of the unit. Supports and anchor bolts are to be designed and furnished by others.
 - All supporting beams are to be flush and level at top and must be oriented relative to gage line as shown.
 - Recommended design loads for each beam should be 80% of the total unit operating weight applied as a uniform load to each beam. Beams should be designed in accordance with standard structural

- practice. The maximum allowable deflection of beams under the unit shall be 1/2 of an inch.
- All mounting holes are 7/8 inch dia. at the locations shown.
- If vibration isolators are used, a rail or channel must be provided between the unit and the isolators to provide continuous unit support. Additionally the support beams must be designed to accommodate the overall length and mounting hole location of the isolators which may differ from those of the unit. Refer to vibration isolator drawings for these data.

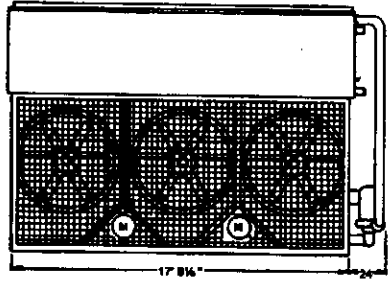

- NOTES:**
- All dimensions are in feet and inches. Weights are in pounds.
 - Unless otherwise indicated, all connections 6 inches and smaller are MPT and connections 6 inches and larger are bevelled for welding.
 - Dimensions showing location of coil connections are approximate and should not be used for prefabrication of connecting piping.

B.A.C.
 ORDER NO. 86-1693M
 DATE 7/24/86

BALTIMORE AIRCOIL
 AFFILIATE OF MERCK & CO., INC.

EVAPORATIVE CONDENSER
 DWG. NO. VL9018 C