

/ Marley Aquatower[®] Cooling Tower /

User Manual 01-1248D

Contents

Tower Installation.....	4
Piping to Tower.....	5
Mechanical Equipment Installation	6
Motor Wiring.....	9
Starting and Operating Instructions	12
Maintenance Instructions	14
Cooling Tower Cleaning	16
Blowdown.....	17
Seasonal Shutdown Instructions.....	18
Troubleshooting.....	19
Wiring Diagrams	20
Parts List	23

The following defined terms are used throughout this manual to bring attention to the presence of hazards of various risk levels, or to important information concerning the life of the product.

⚠ Warning

Indicates presence of a hazard which can cause severe personal injury, death or substantial property damage if ignored.

⚠ Caution

Indicates presence of a hazard which will or can cause personal injury or property damage if ignored.

Note

Indicates special instructions on installation, operation or maintenance which are important but not related to personal injury hazards.

This Manual contains vital information for the proper installation and operation of your cooling tower. Carefully read the manual before installation or operation of the tower and follow all instructions. Save this manual for future reference.

Installation

Receiving Inspection

The motor and miscellaneous parts ship with the tower. Check motor nameplate to be sure that power supply and motor have the same characteristics. Inspect the entire shipment for any damage that may have occurred in transit.

Tower Location

⚠ Warning

The cooling tower must be located at such distance and direction to avoid the possibility of contaminated tower discharge air being drawn into building fresh air intake ducts. The purchaser should obtain the services of a Licensed Professional Engineer or Registered Architect to certify that the location of the tower is in compliance with applicable air pollution, fire, and clean air codes.

Locate so prevailing wind will blow into the louvered face, and direct fan discharge away from building surfaces. Locate so there is free air flow to and from the tower. Allow clearance on all sides for maintenance.

Indoor Installation

Use a duct from the tower air discharge to the outside. You may also want to install an inlet air duct. Do not allow the total pressure loss through ducts to exceed 0.10 inches H₂O. To minimize pressure losses:

- Use 20% oversize ducts.
- Avoid sharp turns or abrupt changes in size.
- Keep duct length to a minimum.
- Screened or louvered openings should have a net free area at least 20% greater than the tower discharge opening area.

Attach ducts to the tower using flexible connections, and support ducts independently from the tower. Provide access openings for servicing the mechanical equipment if air discharge ducts are installed. If the duct discharges into the prevailing wind, you may need to install a windbreak or an elbow to serve as a deflector. Ducts installed on towers with year-round usage should be water tight and insulated to prevent condensation.



Installation

Tower Installation

Install tower in a level position on a stable foundation. Anchor tower to the foundation through holes at base of tower, using four $\frac{3}{8}$ " diameter bolts (not supplied). Remove strapping and brackets from the louver face on Models 4940, 4950, and 4960 and reinstall the bolts to the cold water basin.

Piping to Tower (Summer-Only Operation)

1. Use large enough piping to minimize friction loss.
2. Connect float valve to makeup water supply. Install the threaded valve stem and float located in the loose parts package.
3. Install a valved blowdown line at some point in the system, preferably in the hot water line near the top of the tower, so that water will flow through the line whenever the pump is operating. (Blowdown is the continuous removal of a small amount of water during operation to retard scale and corrosion.)

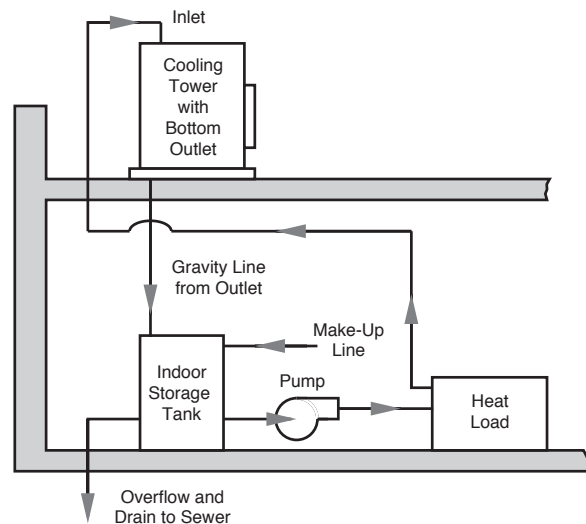

Figure 1

Installation

Piping to Tower (Year-Round Operation)

1. If your tower must operate during freezing weather, it is recommended that the tower be installed for gravity flow operation. See **Figure 1**.
2. Provide an indoor open type storage tank with a capacity that will contain all water that will drain into the tank from the system during shutdown.
3. Connect tower outlet to storage tank. Bottom outlet option should be used for gravity flow.
4. Install makeup water, bleed-off, overflow and drain lines on tank.
5. Insulate and heat water lines exposed to freezing temperatures.

Mechanical Equipment Installation

Note

Aquatowers with factory-installed controls ship with the motor, sheave, belt, and belt guard factory-installed. Remove shipping stiffener plate and hardware at the adjustable end of the motor support plate and proceed to Motor Electrical Connections.

Motor, Sheave, and V-Belt Installation

1. Check the motor nameplate to be sure its voltage, phase and frequency ratings are the same as the power supply. 

Motor Frame	Fastener Size
56-143T-145T	5/16"
182T thru 215T	3/8"

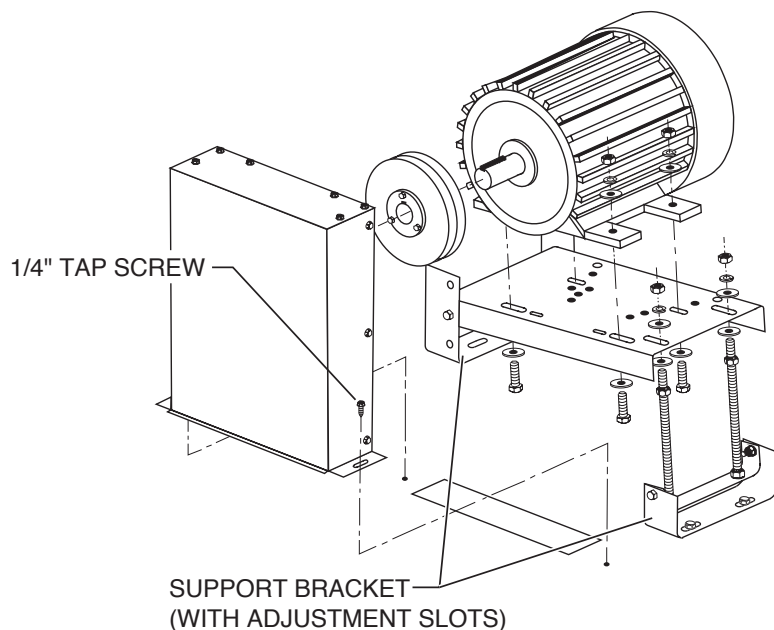

Figure 2

Installation

2. Make sure the fan is tightly secured to the bearing housing shaft and that it rotates freely. Make sure the bearing housing is secured to its support.
3. Attach motor to motor base with four bolts, flat washers, lock washers and nuts provided, see **Figure 2**. You may want to loosen the adjusting bolts and raise the motor base so you can reach under the motor base to tighten the motor hold-down bolts.

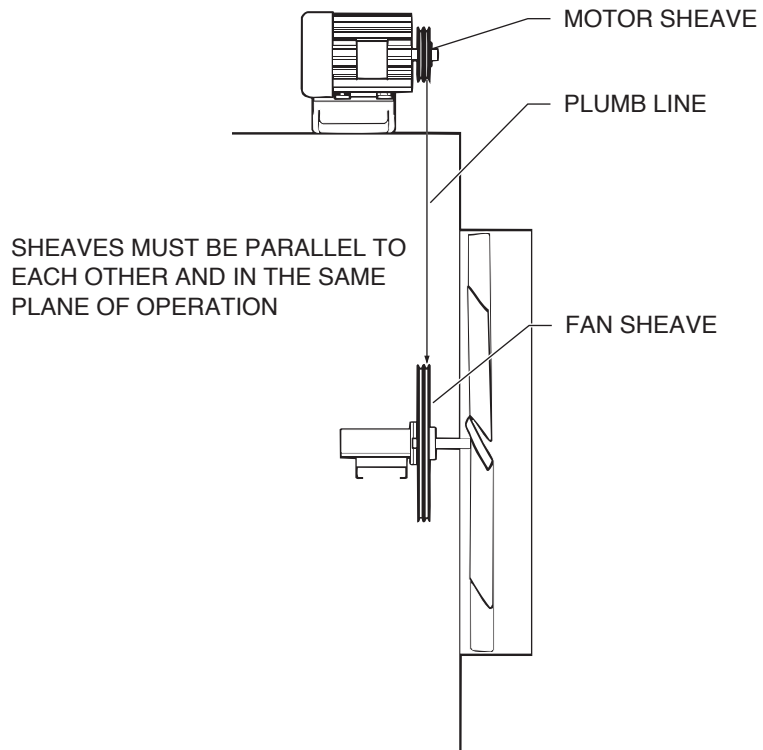

Figure 3

4. Apply a rust preventive coating to the motor shaft to prevent shaft corrosion and to ease sheave installation and removal.
5. Install motor sheave and align it with fan sheave. Motor support brackets are slotted to assist in alignment. See **Figure 2**. A plumb line will be helpful in aligning sheaves. See **Figure 3**.
6. Remove the fan guard and fan cylinder splice plate (Series 4900 only) at the top of the fan cylinder. Install the belt over the fan by passing the belt over the fan and rotating the fan blades past the belt. Install the belt onto the sheaves.

Installation

7. Use the adjusting bolts on the motor support to adjust belt tension. A correctly tensioned belt does not slip when the fan is running—and the “tight” side is straight between sheaves. The “slack” side will have a slight bow. If possible, use a commercially available tension measuring device. **Avoid over-tensioning.** Too much tension reduces bearing and belt life. Check the tension on new belts after 8 to 12 hours of operation.
8. Install the belt guard as shown in **Figure 2**.
9. Install fan cylinder splice plate and fan guard.
10. Check bearing housing oil cup level. Fill to the proper level with SAE 30 (ISO 100) weight oil.

Installation

Motor Wiring

Wire motor leads as shown on the motor nameplate matching the supply voltage. Do not deviate from the motor nameplate wiring.

Either of following symbols may be shown on the motor nameplate – Δ , $\Delta\Delta$, Y, or YY. These symbols represent how the motor is constructed on the inside and in no way have anything to do with a Delta or Wye electrical distribution system serving the motor.

When using a starter:

- Set motor overload protection to 110% of motor nameplate amps. This setting allows the fan motor to operate during cooler weather. During cooler weather it is common for the motor to draw 6 to 10% higher than nameplate amps. High amps are common during tower commissioning when the tower is dry and the ambient air temperature is cool.
- Do not start the motor more than **six** times per hour. Short cycling the tower will cause fuses, breakers or O.L.s to operate and will decrease motor life.

When using a *two-speed* starter:

- Motor rotation must be the same at slow speed and high speed.
- Single winding motor requires a starter with a shorting contactor.
- Two-winding motor requires a starter with out a shorting contactor.
- All two-speed starters must have a 20 second time delay relay when switching from high speed to low speed.
- Do not start the motor more than **six** times per hour (each low speed start and each high speed start count as one start).

When using a VFD:

Before beginning, ensure that the motor is rated for “Inverter Duty” per NEMA MG-1, part 31.

Note

- Set the VFD solid state overload protection to 119% of motor nameplate amps and set “maximum current parameter” in the VFD to motor nameplate amps. “Maximum current parameter” will reduce fan speed and limit amp draw to nameplate amps during cold weather operation. If furnished with a mechanical O.L. set this at 110% over motor nameplate amps.
- Motor rotation must be the same in both VFD mode and By-pass mode.

Installation

- If cable distance between the VFD and motor is greater than 100 feet a DV/DT output filter is recommended to avoid damage to the motor. 100 feet distance is based on our field experience, the VFD manufacture may state different distances and distance does vary depending on the VFD manufacture.
- Program the VFD for variable torque output. Flux vector and constant torque modes may damage the gearbox.
- Do not start and stop the motor using the safety switch at the motor. If the drive is being commanded to run and the load side is cycled ON and OFF with the safety switch this may damage the VFD.

Using a VFD in cooling applications has advantages over traditional single or two speed motor control. A VFD can reduce the cost of electrical energy being used and provide better temperature control. In addition, it reduces the mechanical and electrical stress on the motor and mechanical equipment. Electrical savings can be large during periods of low ambient temperature when the cooling requirement can be satisfied at reduced speeds. To benefit from these advantages, it is important that the drive be installed correctly.

Marley supplies VFD and VFD controls specifically designed for our cooling products. If you have purchased a Marley VFD and/or controls package, please follow the instructions in the *User Manual* for that system. Most VFD problems can be avoided by purchasing the Marley drive system. If you are installing a VFD other than the Marley drive, please refer to that drives installation manual.

⚠ Warning

Improper use of a VFD may cause damage to equipment or personal injury. Failure to correctly install the VFD drive will automatically void all warranties associated with the motor and any equipment that is either electrically or mechanically (directly) attached to the VFD drive system. The length of this warranty avoidance will be contingent on properly installing the VFD system and repairing any damage that may have occurred during its operation. SPX Cooling Technologies does not assume responsibility for any technical support or damages for problems associate with non-Marley brand VFD systems.

⚠ Warning

Changing the operational fan speed from the factory settings could cause the fan to operate in an unstable region which may result in damage to the equipment and possible injury.

Installation

Motor Electrical Connections

Note

If Aquatower is equipped with Marley Control System, refer to Control System Manual for wiring instructions.

Connect motor to power supply in accordance with the National Electric Code and local requirements. Failure to wire the motor correctly will void its warranty. Overload protection for motors must be part of the control system. **Figure 4** shows one possible control scheme. Other various wiring diagrams appear on pages 20 thru 22.

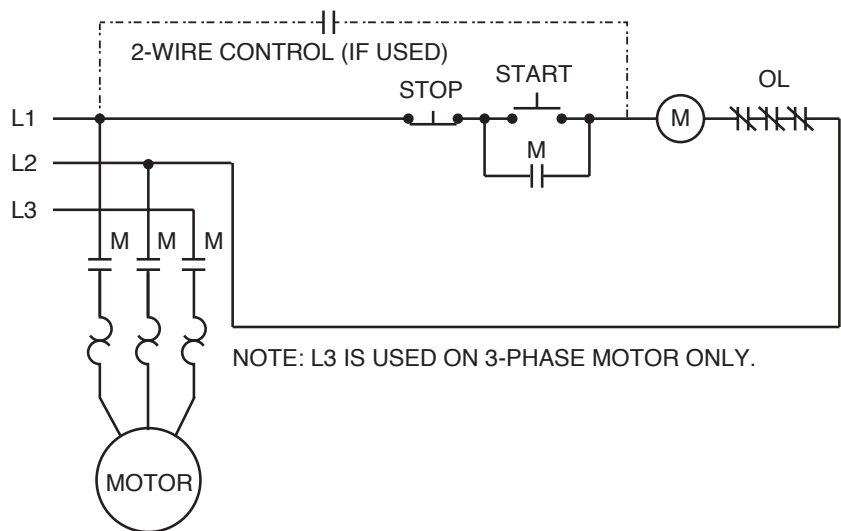

Figure 4

Operation

Starting and Operating Instructions

Warning

Among other sources, outbreaks of Legionnaires' Disease have reportedly been traced to cooling towers. Maintenance and water treatment procedures that prevent amplification and dissemination of Legionella and other airborne bacteria should be formulated and implemented BEFORE systems are operated and continued regularly thereafter to avoid the risk of sickness or death.

1. New installations should be cleaned and treated with biocides by a water treatment expert before startup.
2. Clean all debris, such as leaves and dirt from the cooling tower fill and basin.
3. Fill the circulating system with water. The cold water basin should be filled with water until level is at the rim of the overflow.

The water conditions during the initial tower operation are crucial in preventing premature corrosion of galvanized steel (white rust). For at least the first eight weeks of operation, pH should be controlled between 6.5 and 8.0 with hardness and alkalinity levels between 100 and 300 ppm (expressed as CaCO₃).

Note

If tower is equipped with a standard side-suction connection, vent any accumulated air from the top of the suction hood by removing one or both tap screws provided at that location. Replace these tap screws when venting is complete.

4. Start your pump(s). Observe system operation. Since the water system external to the tower will have been filled only to the level in the cold water basin, some "pump-down" of the basin water level will occur before water completes the circuit and begins to fall from the fill. The initial pump-down may not be enough to cause the float valve to open. However, you can check its operation by pressing down on the operating lever. Adjust the float valve during tower operation with heat load to maintain 4" water depth in the depressed section of the basin on Models 490A through 493B. Maintain 5½" water depth on Models 494A through 496B.

Note

Hot water temperatures exceeding 125°F could damage PVC fill.



Operation

5. Make sure blowdown line is discharging water.
6. Depth of water in hot water basin should be uniform. If the basin overflows, reduce the flow rate. Do not pump more water than design capacity.
7. Continue pump operation for about 15 minutes, after which it is recommended that the water system be drained, flushed, and refilled.
8. While operating the condensing water pump(s) and prior to operating the cooling tower fan, execute one of the two alternative biocidal treatment programs described in the following:
 - Resume treatment with the biocide which had been used prior to shutdown. Utilize the services of the water treatment supplier. Maintain the maximum recommended biocide residual (for the specific biocide) for a sufficient period of time (residual and time will vary with the biocide) to bring the system under good biological control.
 - or***
 - Treat the system with sodium hypochlorite to a level of 4 to 5 mg/L (ppm) free chlorine residual at a pH of 7.0 to 7.6. The chlorine residual must be held at 4 to 5 mg/L (ppm) for six hours, measurable with standard commercial water test kits.

If the cooling tower has been in operation and then shut down for a duration of time and not drained, perform one of the two previous biocidal treatment programs directly to the cooling water storage vessel (cooling tower sump, drain down tank, etc.) without circulating stagnant water over the cooling tower fill or operating the cooling tower fan.

After biocidal pretreatment has been successfully completed, cooling water may be circulated over the tower fill with the fan off.

When biocidal treatment has been maintained at a satisfactory level for at least six hours, the fan may be turned on and the system returned to service. Resume the standard water treatment program, including biocidal treatment.

9. Check fan for free rotation and check oil level in bearing housing as required (see maintenance instructions). Start motor and check direction of rotation. Fan must rotate clockwise when viewed from the fan discharge side. If the rotation is incorrect, change any two of the three motor leads.

Note

Do not allow the total motor acceleration time to exceed 30 seconds per hour.

Maintenance

⚠ Warning

Maintenance Instructions

Always make certain that mechanical equipment is inoperable during periods of maintenance—or during any situation of possible endangerment to personnel. If your electrical system contains a disconnect switch, lock it out until the period of exposure to injury is over.

The top of the tower is not a working surface. Do not stand, sit or walk on top of the tower. Use an appropriate ladder adjacent to the tower whenever you perform any maintenance activity on the tower's upper surfaces.

This product is constructed using cold-formed sheet metal. Use protective clothing, gloves and shoes as appropriate for protection against edges of thin gage material.

Motor

Lubricate the motor according to the motor manufacturer's supplied instructions. Remove any oil, dust or scale deposits from the motor which can cause excessive insulation temperatures.

Refer to *Electric Motors on Cooling Towers*, Manual 92-1475, for additional maintenance and lubrication information.

Fan Shaft Bearing Housing

Check bearing housing oil cup level. Fill to the proper level with SAE 30 (ISO 100) weight oil.

Belt Tension

Check belt tension every two to three weeks during peak operating season.

Makeup Float Valve

Check float valve periodically for proper operation and proper water level.

Basin and Suction Screen

Drain and clean cold water basin and suction screen periodically.

Blowdown

Check the blowdown for continuous water discharge during operation.

Maintenance Schedule

Maintenance Service	Monthly	Semi-annually	Seasonal Startup or Annually
Inspect General Condition and Operation	x		x
Observe Operation of:			
Mechanical—motor, fan and drive mechanism	x		x
Makeup valve (if equipped)	x		x
Inspect for unusual noise or vibration	x		x
Inspect and Clean:			
Air inlet	x		x
PVC drift eliminators	x		x
Distribution basin, nozzles and collection basin	x		x
Fan motor exterior	x		x
Check:			
Collection water basin level	x		x
Blowdown—adjust as required	x		x
Belt drive:			
Fan shaft bearing lubrication (every 3 mo.)		every 3 months	every 3 months
Check and tighten support fasteners			x
Check shaft, sheave and belt alignment			x
Check belt tension and condition		x	x
Check sheave bushing fastener torque			x
Fan:			
Check and tighten blade and hub fasteners			x
Check fan blade pitch and tip clearance			x
Check fan cylinder for loose fasteners			x
Motor:			
Lubricate (grease as required)			R
Check mounting bolts for tightness			x
Operate at least	3 hours a month	3 hours a month	3 hours a month
Basin Heater (if equipped):			
Check for proper operation of temp/low water level sensor			x
Inspect/clean buildup of contaminant from sensor		x	x
Structure:			
Inspect/tighten all fasteners		x	x
Inspect and touch up all metal surfaces			x

R — Refer to Component User Manual

Note: It is recommended at least weekly, that the general operation and condition be observed. Pay attention to any changes in sound or vibration that may signify a need for closer inspection.

Maintenance

Cooling Tower Cleaning

⚠ Warning

Any evaporative-type cooling tower must be thoroughly cleaned on a regular basis to minimize the growth of bacteria, including Legionella Pneumophila, to avoid the risk of sickness or death. Service personnel must wear proper personal protective equipment during decontamination. Do NOT attempt any service unless the fan motor is locked out.

Operators of evaporative cooling equipment, such as water cooling towers, should follow maintenance programs which will reduce to an absolute minimum the opportunity for bacteriological contamination. Public Health Service officials have recommended that “good housekeeping” procedures be followed, such as: regular inspections for concentrations of dirt, scale, and algae; periodic flushing and cleaning; and the following of a complete water treatment program including biocidal treatment. See **Starting and Operating Instructions** on page 12.

A visual inspection should take place at least once a week during the operating season. Inspect for bacterial growth and general operation conditions. Bacterial growth should be reported to your water treatment expert for immediate attention. At a minimum, cooling towers should be cleaned and disinfected with biocides twice a year. Systems with biofouling or positive cultures of legionella may require additional cleaning.

Inspect louvers, drift eliminators and basin trash screens and remove any debris or scale which may have accumulated. Replace any damaged or worn out components. The louvers, drift eliminators and easily accessible fill surfaces should be flushed by use of a moderate-pressure water nozzle, being careful not to cause physical damage. Use of high-pressure water may damage the eliminator and louver material. A reliable water treatment program should be installed and maintained. Filtration devices may be employed to reduce the suspended solids concentrations, thus increasing the effectiveness of the water treatment program.

Maintenance

Blowdown

A cooling tower cools water by continuously causing a portion of it to evaporate. Although the water lost by evaporation is replenished by the makeup system, it exits the tower as pure water—leaving behind its burden of dissolved solids to concentrate in the remaining water. Given no means of control, this increasing concentration of contaminants can reach a very high level.

In order to achieve water quality which is acceptable to the cooling tower (as well as the remainder of your circulating water system), the selected water treatment company must work from a relatively constant level of concentrations. This stabilization of contaminant concentrations is usually accomplished by blowdown, which is the constant discharge of a portion of the circulating water to waste. As a rule, acceptable levels on which to base a treatment schedule are in the range of 2–4 concentrations. The following table gives approximate blowdown rates (percent of total water flow rate constantly wasted) to achieve those concentrations at various cooling ranges*:

Blowdown Rate		
Cooling Range (°F)	Two Concentrations	Four Concentrations
10	0.7%	0.17%
15	1.1%	0.30%
20	1.5%	0.43%

* Range is the difference between hot water temperature entering the tower and cold water temperature leaving the tower.

Note

When water treatment chemicals are added, they should not be introduced into the circulating water system via the cold water basin of the cooling tower. Water velocities are lowest at that point, which results in inadequate mixing and may damage the cooling tower.

Intermittent Wintertime Operation:

If periods of shutdown (nights, weekends, etc.) occur during freezing weather, measures must be taken to prevent the water in the cold water basin—and all exposed pipework—from freezing. Several methods are used to combat this, including Marley automatic basin heater system.

Unless some means of freeze prevention is incorporated into your system, the tower basin and exposed pipework should be drained at the beginning of each wintertime shutdown period.

If tower basin is drained, verify that all basin heaters have been shut off either by automatic cutoff or disconnect switch.

⚠ Caution

⚠ Warning

Maintenance

Seasonal Shutdown Instructions

When the system is to be shut down for an extended period of time, it is recommended that the entire system (cooling tower, system piping, heat exchangers, etc.) be drained. Leave the basin drain open.

During shutdown, clean the tower and make any necessary repairs. Apply protective coating as required to all metal parts. Pay particular attention to bearing housing supports.

Bearing Housing

- At shutdown, check the oil level in the oil cup.
- At start of new operating season, operate until the oil is warm—drain and refill. Use SAE 30 (ISO 100) weight oil.
- Bearing housing must be refilled at the point where the oil line from the oil reservoir cup connects to the bearing housing. Attach oil line and fill line and oil cup. Fan guard will have to be removed to change oil. Each month check the oil level at the oil cup.

Electric Motor

Clean and lubricate motor at close of each operating season. Refer to motor manufacturer's recommendations.

Warning

Do not start motor before determining that there will be no interference with free rotation of the fan drive.

The motor should be run for three hours at least once a month to dry out windings and relubricate bearing surfaces. Refer to *Electric Motors on Cooling Towers*, Manual 92-1475.

At start of new operating season, make sure bearings are adequately lubricated before returning motor to service.

Prolonged Shutdown

If shutdown period is longer than seasonal, contact your Marley Sales Representative for additional information.

Note

Whenever you order parts or correspond with us about your tower, please include the tower serial number located on the tower's name plate.

Troubleshooting

Trouble	Cause	Remedy
Unusual motor noise	Motor running single-phase	Stop motor and attempt to start it. Motor will not start if single-phased. Check wiring, controls and motor.
	Motor leads connected incorrectly	Check motor connections against wiring diagram on motor.
	Bad bearings	Check lubrication. Replace bad bearings.
	Electrical unbalance	Check voltage and currents of all three lines. Correct if required.
	Rotor unbalance	Rebalance.
Motor runs hot	Motor overload, wrong voltage or unbalanced voltage	Check voltage and current of all three lines against nameplate values.
	Wrong fan RPM	Check nameplate RPM of motor and sheave ratio against parts list. Measure RPM.
	Bearings overgreased	Remove grease reliefs. Run motor up to speed to purge excessive grease.
	Wrong lubricant in bearings	Change to proper lubricant. See motor manufacturer's instructions.
	One phase open	Stop motor and attempt to start it. Motor will not start if single-phased. Check wiring, controls and motor.
	Poor ventilation	Clean motor and check ventilation openings. Allow ample ventilation around motor.
	Winding fault	Check with Ohmmeter.
	Bent motor shaft	Straighten or replace shaft.
	Insufficient grease	Remove plugs and regrease bearings.
	Too frequent starting	Limit cumulative starting time to a total of 30 seconds each hour.
	Deterioration of or foreign material in grease	Flush bearings and relubricate.
Unusual fan drive vibration	Bearings damaged	Replace bearings.
	Loose bolts and cap screws	Tighten all bolts and cap screws on all mechanical equipment and supports.
	Worn fan shaft bearings	Replace bearings.
	Bent shaft	Replace shaft.
	Misalignment	Make sure fan and motor are straight and properly aligned.
	Loose or stretched belt	Check belt for proper tension.
	Unbalanced motor	Disconnect load. Remove sheave, tape key in keyway and operate motor. If motor still vibrates, rebalance motor.

Wiring Diagrams

Capacitor Start Single Phase Motors, Reversible, Double Voltage

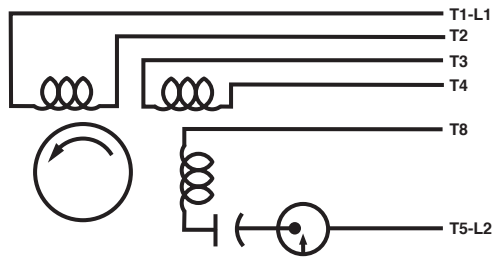

Without Thermal Overload (Integral HP)

High Voltage

1. Connect T1 and L1 and insulate.
2. Connect T2, T3 and T8 and insulate.
3. Connect T4, T5 and L2 and insulate.

Low Voltage

1. Connect T2, T3, T8 and L1 and insulate.
2. Connect T2, T4, T5 and L2 and insulate.

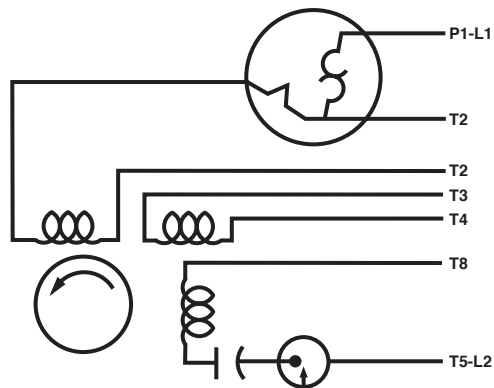

With Thermal Overload (Fractional HP)

High Voltage

1. Insulate P2.
2. Connect T2, T3 and L8 and insulate.
3. Connect T4, T5 and L2 and insulate.
4. Connect P1 and L1 and insulate.



Wiring Diagrams

Low Voltage

1. Connect P1 and L1 and insulate.
2. Connect P2, T3, and T8 and insulate.
3. Connect T2, T4, T5 and L2 and insulate.

General

Colors may be substituted for numbers as follows:

T1—Blue	T5—Black
T2—White	T6—Red
T3—Orange	P1—No Color Assigned
T4—Yellow	P2—Brown

To reverse rotation, interchange leads T5 and T8.

Three Phase Motors

There are two basic ways of wiring a three phase motor, Wye and Delta. The following show the terminal connections that could be used in Marley motors. Numbers could be stamped on insulation or cloth, plastic or metal bands around each lead.

1. Three Wire Single Voltage Motors—Leads are not always numbered. They could be numbered 1,2,3 or T1, T2 and T3.

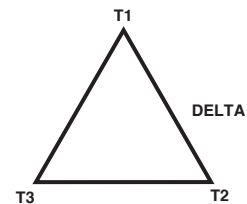
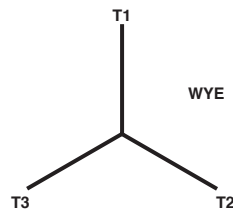

2. Nine Wire Dual Voltage Motors—Leads are numbered 1, 2, 3, 4, 5, 6, 7, 8 and 9 or T1, T2, T3, T4, T5, T6, T7, T8 and T9.

Wiring Diagrams

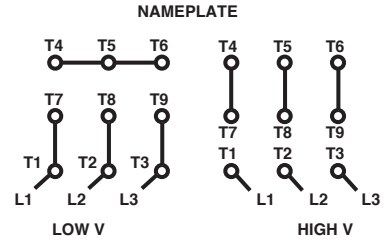
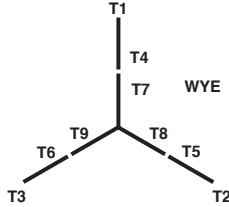

Voltage	L1	L2	L3	Tie Together
Low	T1 T7	T2 T8	T3 T9	T4 T5 T6
High	T1	T2	T3	(T4 T7) (T5 T8) (T6 T9)

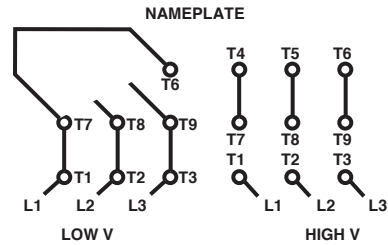
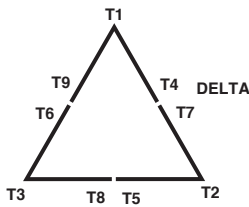

Voltage	L1	L2	L3	Tie Together
Low	(T1 T7 T6)	(T2 T8 T4)	(T3 T5 T9)	
High	T1	T2	T3	(T4 T7) (T5 T8) (T6 T9)

3. Two Speed Single Winding (Consequent Pole) Variable Torque Motor—Leads are marked 1, 2, 3, 4, 5 and 6 or T1, T2, T3, T4, T5 or

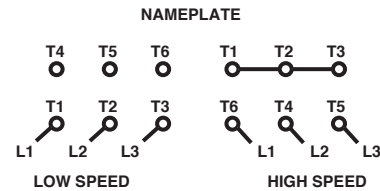
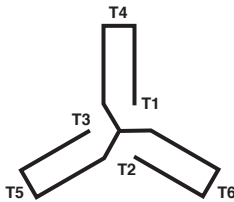

Speed	L1	L2	L3	Tie Together	Insulate Separately
Low	T1	T2	T3		T4-T5-T6
High	T6	T4	T5	T1 T2 T3	

Parts List 4900 Aquatower — 60 Cycle Motor Application

Contact your local Marley sales representative for prices and availability, to place your order, or for help with identifying parts. To find you local Marley sales representative call 800 462 7539 or check the internet at spxcooling.com

Model Number		490A	490B	492A	492B	493A	493B	
V-Belt	A75	693531	693531					
	A112			221820	221820			
	A103					564534		
	A105						320333	
Motor Sheave*		D24662	176552	173534	187880	058891	157503	
Fan Sheave		D24665	D24665	224717	224717	D24665	D24665	
Fan	24" Dia.	D02974	D02974					
	36" Dia.			D02975	D02975			
	42" Dia.					D02976	D02976	
1301SE Bearing Housing		C72316	C72316	C72316	C72316	C72316	C72316	
Fan Guard	24" Dia. HDG	C53623	C53623					
	36" Dia. HDG			C53624	C53624			
	42" Dia. HDG					C53625	C53625	
Float Valve	Brass Body 3/4" NPT	155929	155929	155929	155929	155929	155929	
	Brass Stem	720755	720755	720755	720755	720755	720755	
	Plastic Float	720680	720680	720680	720680	720680	720680	

Model Number		494A	494B	494C	495A	495B	496A	496B
V-Belt	2A128	216234	216234	216234				
	B133				D24630			
	B136					D19540		
	2BX136						D24674	D24674
Motor Sheave*		254425	D24663	D24664	D19541	187880	254425	265314
Fan Sheave		D24666	D24666	D24666	B84734	B84734	D24666	D24666
Fan	48" Dia.	D02977	D02977	D02977				
	54" Dia.				D02978	D02978		
	66" Dia.						D02979	D02979
118SE Bearing Housing		574194	574194	574194	574194	574194	574194	574194
Fan Guard	48" Dia. HDG	C53626	C53626	C53626				
	54" Dia. HDG				C53627	C53627		
	66" Dia. HDG						C53628	C53628
Float Valve	Brass Body 3/4" NPT	155929	155929	155929	155929	155929	155929	155929
	Brass Stem	088708	088708	088708	088708	088708	088708	088708
	Plastic Float	720680	720680	720680	720680	720680	720680	720680

Parts List 4900 Aquatower — 50 Cycle Motor Application

Model Number		490A	490B	492A	492B	493A	493B
V-Belt	A75	693531					
	A77		D24672				
	A112			221820			
	A120				197632		
	A105					320333	320333
Motor Sheave*		161505	D24671	D24670	197756	D24669	173492
Fan Sheave		D24665	D24665	224717	224717	D24665	D24665
Fan	24" Dia.	D02974	D02974				
	36" Dia.			D02975	D02975		
	42" Dia.					D02976	D02976
1301SE Bearing Housing		C72316	C72316	C72316	C72316	C72316	C72316
Fan Guard	24" Dia. HDG	C53623	C53623				
	36" Dia. HDG			C53624	C53624		
	42" Dia. HDG					C53625	C53625
Float Valve	Brass Body 3/4" NPT	155929	155929	155929	155929	155929	155929
	Brass Stem	720755	720755	720755	720755	720755	720755
	Plastic Float	720680	720680	720680	720680	720680	720680

Model Number		494A	494B	494C	495A	495B	496A	496B
V-Belt	2A128	216234	216234					
	2A136			D24673				
	B136				D19540	D19540		
	2B140						B32344	B32344
Motor Sheave*		266205	D24664	D19594	196246	D19542	266205	273771
Fan Sheave		D24666	D24666	D24666	B84734	B84734	D24666	D24666
Fan	48" Dia.	D02977	D02977	D02977				
	54" Dia.				D02978	D02978		
	66" Dia.						D02979	D02979
118SE Bearing Housing		574194	574194	574194	574194	574194	574194	574194
Fan Guard	48" Dia. HDG	C53626	C53626	C53626				
	54" Dia. HDG				C53627	C53627		
	66" Dia. HDG						C53628	C53628
Float Valve	Brass Body 3/4" NPT	155929	155929	155929	155929	155929	155929	155929
	Brass Stem	088708	088708	088708	088708	088708	088708	088708
	Plastic Float	720680	720680	720680	720680	720680	720680	720680

* Motor sheave part number shown is for a standard motor frame application. Because of the various motor frame options the Aquatower serial number is required to insure correct sheave replacement part.

Parts List 4900 Aquatower — 60 Cycle Motor

Use this table to identify the Aquatower motor. Contact your local Marley sales representative for prices and availability, to place your order, or for help with identifying the correct motor.

Model Number	490A	490B	492A	492B	493A	493B
Motor 60 Cycle						
1/3 hp 1/60/115/230/1800 rpm 56 Frame*	454215					
1 hp 3/60/200/1800 rpm 143T Frame		C04703	C04703			
1 hp 3/60/230/460/1800 rpm 143T Frame*		C04704	C04704			
1 hp 3/60/575/1800 rpm 143T Frame		C04705	C04705			
2 hp 3/60/200/1800 rpm 145T Frame				C04719	C04719	
2 hp 3/60/230/460/1800 rpm 145T Frame*				C04720	C04720	
2 hp 3/60/575/1800 rpm 145T Frame				C04721	C04721	
3 hp 3/60/200/1800 rpm 182T Frame						C04736
3 hp 3/60/230/460/1800 rpm 182T Frame*						C04737
3 hp 3/60/575/1800 rpm 182T Frame						C04738

Model Number	494A	494B	494C	495A	495B	496A	496B
Motor 60 Cycle							
2 hp 3/60/200/1800 rpm 145T Frame	C04719						
2 hp 3/60/230/460/1800 rpm 145T Frame*	C04720						
2 hp 3/60/575/1800 rpm 145T Frame	C04721						
3 hp 3/60/200/1800 rpm 182T Frame		C04736					
3 hp 3/60/230/460/1800 rpm 182T Frame*		C04737					
3 hp 3/60/575/1800 rpm 182T Frame		C04738					
5 hp 3/60/200/1800 rpm 184T Frame			C11602	C11602		C11602	
5 hp 3/60/230/460/1800 rpm 184T Frame*			C11604	C11604		C11604	
5 hp 3/60/575/1800 rpm 184T Frame			C11606	C11606		C11606	
7 1/2 hp 3/60/200/1800 rpm 213T Frame					C11618		C11618
7 1/2 hp 3/60/230/460/1800 rpm 213T Frame*					C11620		C11620
7 1/2 hp 3/60/575/1800 rpm 213T Frame					C11622		C11622
7 1/2 hp 3/60/208/1800/900 rpm 215T Frame					235085		235085
7 1/2 hp 3/60/460/1800/900 rpm 215T Frame					652636		652636
7 1/2 hp 3/60/575/1800/900 rpm 215T Frame					235168		235168

*Indicates standard motor for each model. Other motors shown are supplied for particular electrical supply characteristics. Check the motor nameplate before you order.

Parts List 4900 Aquatower — 50 Cycle Motor

Use this table to identify the Aquatower motor. Contact your local Marley sales representative for prices and availability, to place your order, or for help with identifying the correct motor.

Model Number	490A	490B	492A	492B	493A	493B
Motor 50 Cycle						
1/3 hp 1/50/115/230/1500 rpm 56 Frame	205492					
1 hp 3/50/220/380/1500 rpm 143T Frame		221176	221176			
2 hp 3/50/220/380/1500 rpm 182T Frame				223974	223974	
3 hp 3/50/220/380/1500 rpm 182T Frame						230722

Model Number	494A	494B	494C	495A	495B	496A	496B
Motor 50 Cycle							
2 hp 3/50/220/380/1500 rpm 182T Fram	223974						
3 hp 3/50/220/380/1500 rpm 182T Frame		230722					
5 hp 3/50/220/380/1500 rpm 213T Frame			233056	233056			
7½ hp 3/50/220/380/1500 rpm 215T Frame					235275	233056	235275

SPX **Cooling Technologies**

Balcke | Hamon Dry Cooling | Marley

/ 7401 W 129 Street // Overland Park, KS USA 66213 // +1 913 664 7400 // spxcooling@ct.spx.com // www.spxcooling.com /

In the interest of technological progress, all products are subject to design and/or material change without notice
©2007 SPX Cooling Technologies, Inc. | Printed in USA

Manual 01-1248D