

Graco Power Flo Air Powered Pump Model 2065 96

Mfg: Graco

Model: 2065 96

Stock No. 35.139

Serial No. 71

Graco, Power Flo Air Powered Pump, Model 2065 96, S/N 71. Ratio 10:1. Overall dimensions: 10 in. W, 10 in. L, 46 in. H. Maximum supply air pressure 120 psi. This pump can handle 1,000 psi fluid pressure, has 3/4 npsm female inlet, 4 in. fluid inlet, 1-1/2 in. npt female fluid outlet. Cost new about \$5,100

Technical Specifications

- Fluid to air pressure ratio 10:1
 - Maximum fluid pressure 1000 psi (70 bar; 7 MPa)
 - Maximum fluid flow at 100 cpm 13.3 gpm (50.3 lpm)
 - Maximum fluid flow at 60 cpm 8 gpm (31 lpm)
 - Maximum volume per cycle 0.14 gal. (0.54 liter)
 - Maximum air input pressure 100 psi (7 bar; 0.7 MPa)
 - Air inlet size 3/4 npsm(f)
 - Fluid inlet size 4 in. (10.2 cm)
 - Fluid outlet size 1-1/2 npt(f)
 - Weight 101 lbs. (46 kg)
 - Wetted parts SST, Teflon®, UHMWPE, Acetal, Delrin®
 - Instruction manual 306916
- Teflon® and Delrin® are registered trademarks of DuPont.*



Bulldog[®] and King[®] Pumps

306916S

Stainless Steel with PTFE Packings and Priming Piston

See [List of Models](#) and [Table of Contents](#) on page 2.

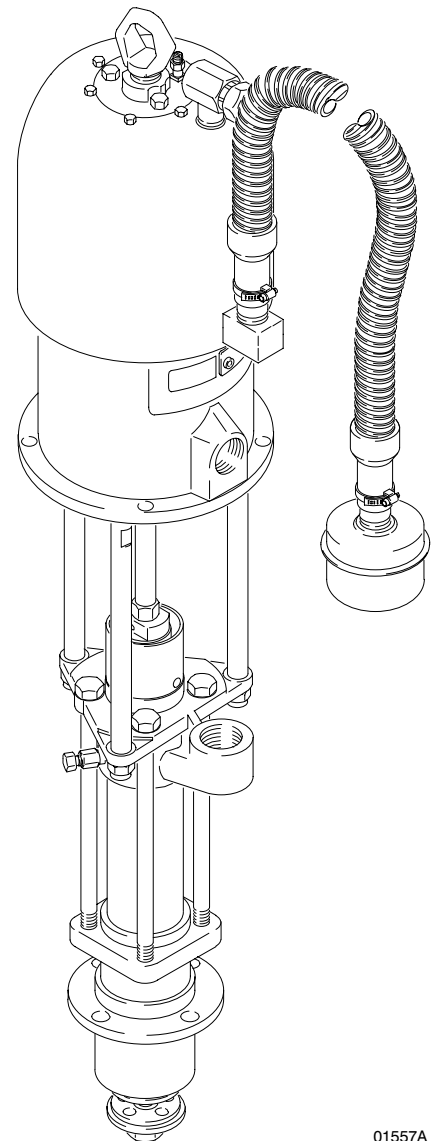

01557A

List of Models

Part No. (Series)	Pump Type	Pump Size	Ratio	Maximum Fluid Working Pressure	Maximum Pump Air Input Pressure
949444 (A)	Bulldog	55 gal. (200 liter) Drum	10:1	1000 psi (7 MPa, 70 bar)	100 psi (0.7 MPa, 7 bar)
954180 (A)	Bulldog	55 gal. (200 liter) Drum	10:1	1000 psi (7 MPa, 70 bar)	100 psi (0.7 MPa, 7 bar)
220648 (B)	King	55 gal. (200 liter) Drum	20:1	1800 psi (12 MPa, 124 bar)	90 psi (0.6 MPa, 6.2 bar)

Table of Contents

Warnings	2	Parts	14
Typical Installation	7	Dimensions	18
Installation	7	Mounting Hole Layout	18
Operation	8	Technical Data	19
Troubleshooting	10	Graco Warranty	20
Service	11	Graco Information	20

Symbols

Warning Symbol



This symbol alerts you to the possibility of serious injury or death if you do not follow the instructions.

Caution Symbol



This symbol alerts you to the possibility of damage to or destruction of equipment if you do not follow the instructions.

WARNING



INSTRUCTIONS

EQUIPMENT MISUSE HAZARD

Equipment misuse can cause the equipment to rupture or malfunction and result in serious injury.

- This equipment is for professional use only.
- Read all instruction manuals, tags, and labels before operating the equipment.
- Use the equipment only for its intended purpose. If you are not sure, call your Graco distributor.
- Do not alter or modify this equipment. Use genuine Graco parts and accessories.
- Check equipment daily. Repair or replace worn or damaged parts immediately.
- Do not exceed the maximum working pressure stated on the equipment or in the **Technical Data** for your equipment. Do not exceed the maximum working pressure of the lowest rated component in your system.
- Use fluids and solvents which are compatible with the equipment wetted parts. Refer to the **Technical Data** section of all equipment manuals. Read the fluid and solvent manufacturer's warnings.
- Handle hoses carefully. Do not pull on hoses to move equipment.
- Route hoses away from traffic areas, sharp edges, moving parts, and hot surfaces. Do not expose Graco hoses to temperatures above 66°C (150°F) or below -40°C (-40°F).
- Wear hearing protection when operating this equipment.
- Do not move or lift pressurized equipment.
- Comply with all applicable local, state, and national fire, electrical, and safety regulations.

WARNING

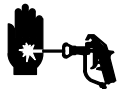

INJECTION HAZARD

Spray from the valve, leaks or ruptured components can inject fluid into your body and cause extremely serious injury, including the need for amputation. Fluid splashed in the eyes or on the skin can also cause serious injury.

- Fluid injected into the skin is a serious injury. The injury may look like just a cut, but it is a serious injury. Get immediate medical attention.
- Do not point the valve at anyone or at any part of the body.
- Do not put your hand or fingers over the valve tip.
- Do not stop or deflect leaks with your hand, body, glove or rag.
- Do not “blow back” fluid; this is not an air spray system.
- Always have the tip guard and the trigger guard on the valve when spraying.
- Be sure the valve trigger safety operates before dispensing.
- Lock the valve trigger safety when you stop dispensing.
- Follow the **Pressure Relief Procedure** on page 8 if the spray tip clogs and before cleaning, checking or servicing the equipment.
- Tighten all fluid connections before operating the equipment.
- Check the hoses, tubes, and couplings daily. Replace worn, damaged, or loose parts immediately. Permanently coupled hoses cannot be repaired; replace the entire hose.



MOVING PARTS HAZARD

Moving parts, such as the pump’s priming piston, can pinch or amputate your fingers.

- Keep clear of all moving parts when starting or operating the pump.
- Keep hands and fingers away from the priming piston during operation and whenever the pump is charged with air.
- Before checking or servicing the equipment, follow the **Pressure Relief Procedure** on page 8 to prevent the equipment from starting unexpectedly.

WARNING



FIRE AND EXPLOSION HAZARD

Improper grounding, poor ventilation, open flames or sparks can cause a hazardous condition and result in a fire or explosion and serious injury.



- Ground the equipment and the object being sprayed. Refer to **Grounding** on page 6.
- If there is any static sparking or you feel an electric shock while using this equipment, **stop spraying immediately**. Do not use the equipment until you identify and correct the problem.
- Provide fresh air ventilation to avoid the buildup of flammable fumes from solvents or the fluid being sprayed.
- Keep the spray area free of debris, including solvent, rags, and gasoline.
- Before operating this equipment, electrically disconnect all equipment in the spray area.
- Before operating this equipment, extinguish all open flames or pilot lights in the spray area.
- Do not smoke in the spray area.
- Do not turn on or off any light switch in the spray area while spraying or while operating if fumes are present.
- Do not operate a gasoline engine in the spray area.



TOXIC FLUID HAZARD

Hazardous fluid or toxic fumes can cause serious injury or death if splashed in the eyes or on the skin, inhaled, or swallowed.

- Know the specific hazards of the fluid you are using.
- Store hazardous fluid in an approved container. Dispose of hazardous fluid according to all local, state and national guidelines.
- Always wear protective eyewear, gloves, clothing and respirator as recommended by the fluid and solvent manufacturer.

Installation

General Information

NOTE: Reference numbers and letters in parentheses in the text refer to the callouts in the Installation and Parts drawings.

NOTE: Always use Genuine Graco Parts and Accessories, available from your Graco distributor.

Grounding

WARNING



FIRE AND EXPLOSION HAZARD

Before operating the pump, ground the system as explained below. Also read the section **FIRE AND EXPLOSION HAZARD** on page 5.

1. *King Pumps:* Use a ground wire and clamp as shown in Fig. 1. Remove the ground screw (Z) and insert through eye of ring terminal at the end of ground wire (Y). Fasten ground screw back onto pump and tighten securely. Connect the other end of the wire to a true earth ground. Order Part No. 222011 Ground Wire and Clamp.

Bulldog Pumps: Use a ground wire and clamp as shown in Fig. 2. Loosen the grounding lug locknut (W) and washer (X). Insert one end of a 12 ga (1.5 mm²) minimum ground wire (Y) into the slot in lug (Z) and tighten the locknut securely. Connect the other end of the wire to a true earth ground.

2. *Air and fluid hoses:* Use only electrically conductive hoses with a maximum of 500 ft (150 m) combined hose length to ensure grounding continuity,
3. *Air compressor:* Follow the manufacturer's recommendations.

4. *Spray gun/dispersing valve:* Grounding is obtained through connection to a properly grounded fluid hose and pump.
5. *Fluid supply container:* According to your local code
6. *Object being sprayed:* According to your local code.
7. *All solvent pails used when flushing:* According to your local code. Use only metal pails, which are conductive, placed on a grounded surface. Do not place the pail on a nonconductive surface, such as paper or cardboard, which interrupts the grounding continuity.
8. *To maintain grounding continuity when flushing or relieving pressure,* always hold a metal part of the gun/valve firmly to the side of a grounded metal pail, then trigger the gun/valve.

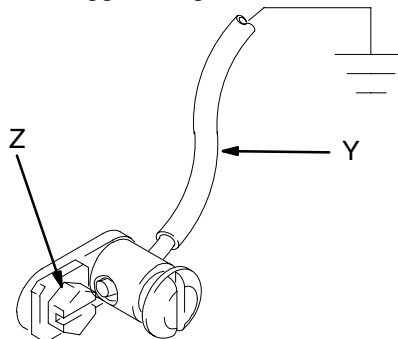

Fig. 1

T11052

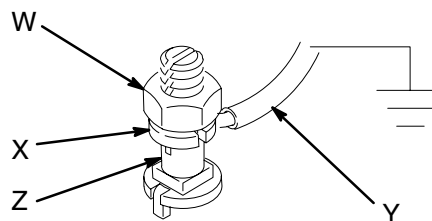

Fig. 2

Installation

Typical Installation

KEY

- A Grounded Air Hose to Pump
- B Air Line Filter
- C Air Regulator and Gauge
- D Bleed-Type Master Air Valve (required, for pump)
- E Air Line Lubricator
- F Pump Runaway Valve
- G Air Powered Ram
- H Fluid Drain Valve (required)
- J Bleed-Type Master Air Valve (for accessories)
- K Air Exhaust Hose (Models 949444 and 954180 only)
- L Muffler (Models 949444 and 954180 only)
- M Fluid Hose
- N Whip Hose
- P Gun/Dispensing Valve
- R Air Supply Hose to Ram
- Y Pump Ground Wire

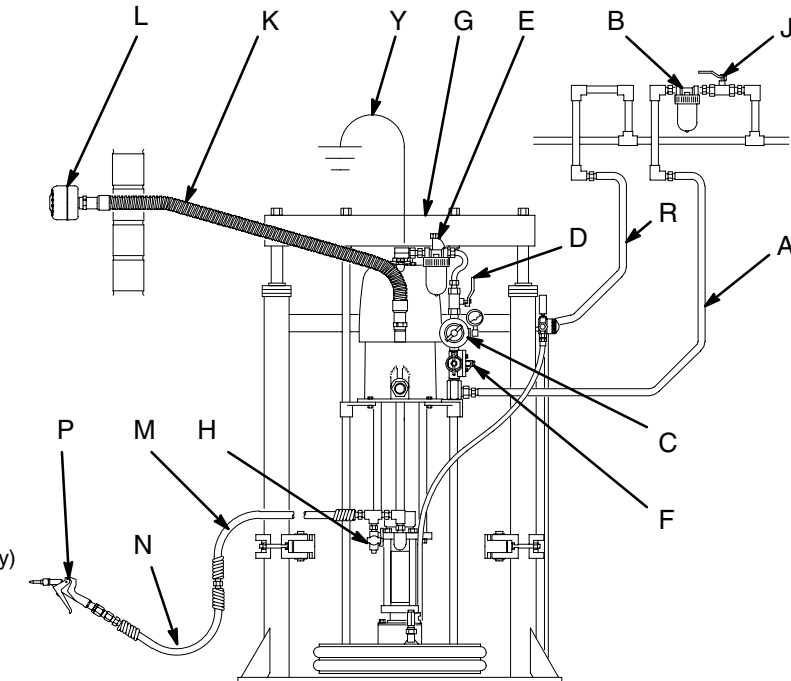

01559

The Typical Installation above is only a guide to selecting and installing accessories. For assistance in designing a system to meet your needs, contact your Graco distributor.

The Dimensional Drawings on page 18 provide necessary measurements for mounting the pump. If you use an accessory ram (G), as shown in the Typical Installation, refer to the separate ram manual for mounting dimension requirements.

System Accessories

Install the air line accessories in the order shown in the Typical Installation. Working upstream from the pump air inlet, install an air line lubricator (E) for automatic air motor lubrication, a bleed-type master air valve (D) to relieve air trapped between the valve and the pump, and an air regulator (C) to control pump speed. Install a pump runaway valve (F) to shut off the air to the pump if the pump accelerates beyond the preadjusted setting. A pump which runs too fast can be seriously damaged.

Install an air line filter (B) to remove harmful dirt and moisture from the compressed air supply, and a second bleed valve (J) to isolate the accessories for servicing. Be sure the pump air line (A) is properly grounded, and is large enough to supply an adequate volume of air to the motor.

! WARNING

A bleed-type master air valve (D) and a fluid drain valve (H) are required in your system. These accessories help reduce the risk of serious injury including fluid injection, splashing in the eyes or on the skin, and injury from moving parts if you are adjusting or repairing the pump.

The bleed-type master air valve relieves air trapped between this valve and the pump after the air is shut off. Trapped air can cause the pump to cycle unexpectedly. Position the valve close to the pump.

The fluid drain valve assists in relieving fluid pressure in the displacement pump, hose and gun; triggering the gun to relieve pressure may not be sufficient.

On the pump fluid line (M), install a fluid drain valve (H) close to the pump fluid outlet.

NOTE: To use the optional fluid outlet at the base of the air motor, connect a riser tube between the standard outlet and the optional outlet.

On models 949444 and 954180 only, connect the air exhaust hose (K) and muffler (L) to the air motor.

Operation

Pressure Relief Procedure

WARNING



INJECTION HAZARD

Fluid under high pressure can be injected through the skin and cause serious injury. To reduce the risk of an injury from injection, splashing fluid, or moving parts, follow the **Pressure Relief Procedure** whenever you:

- are instructed to relieve the pressure,
- stop spraying/dispensing,
- check or service any of the system equipment,
- or install or clean the spray tips/nozzles.

1. Lock the gun/valve trigger safety.
2. Shut off the air to the pump.
3. Close the bleed-type master air valve (required in your system).
4. Unlock the gun/valve trigger safety.
5. Hold a metal part of the gun/valve firmly to the side of a grounded metal pail, and trigger the gun/valve to relieve pressure.
6. Lock the gun/valve trigger safety.
7. Open the drain valve and/or the pump bleeder valve (required in your system), having a container ready to catch the drainage.
8. Leave the drain valve open until you are ready to dispense again.

*If you suspect that the spray tip or hose is completely clogged, or that pressure has not been fully relieved after following the steps above, **very slowly** loosen the tip guard retaining nut or hose end coupling and relieve pressure gradually, then loosen completely, then clear the tip or hose.*

WARNING



MOVING PARTS HAZARD

Moving parts can pinch or amputate your fingers or other body parts. When the pump is operating, the priming piston (located at the pump intake) and the air motor piston (located behind the air motor shield) move. Therefore, never operate the pump with the air motor shield removed, and keep your fingers and hands away from the priming piston.

Before attempting to clear an obstruction from the priming piston or service the pump, **relieve the pressure** to prevent the pump from starting accidentally.

Flush the Pump Before Using

This pump was tested with water, and some of it may still be in the pump. If the water will contaminate the fluid you are pumping, flush it out with a compatible solvent before using.

Keep the packing nut/wet-cup (45) one-half full with Graco Throat Seal Liquid (TSL), to help prevent the fluid being pumped from drying on the displacement rod and damaging the packings. See Fig. 3. Do not use TSL with food or sanitary applications.

Starting and Adjusting the Pump

1. Make sure the air regulator (C), drain valve (H), and pump bleeder valve plug (52) are closed.
2. Open the bleed-type master air valve (D).
3. Hold a metal part of the gun/valve firmly to the side of a grounded metal pail, and trigger the gun/valve.
4. Slowly open the air regulator (C) until the pump starts running slowly (about 20 psi [1.4 bar, 0.14 MPa]). Run the pump slowly until all the air is purged from the pump and lines.
5. If the pump is not priming properly, open the bleeder valve plug (52) slightly. Use the bleed hole on the underside of the valve body (50) as a priming valve until the fluid appears at the hole. Close the plug (52).

WARNING

To reduce the risk of fluid injection, do not use your hand or fingers to cover the bleeder hole when priming the pump.

Operation

6. Release the trigger and lock the trigger safety. The pump will stall against pressure.
7. In a direct supply system, the pump will start and stop as the gun/valve is opened and closed. In a circulating system, it will run continuously and speed up or slow down as the system demands. Always use the lowest pressure necessary to obtain the desired results.

⚠ WARNING

To reduce the risk of serious injury, including fluid injection and splashing in the eyes or on the skin, and property damage, never exceed the maximum air and fluid working pressure of the lowest rated component in your system.

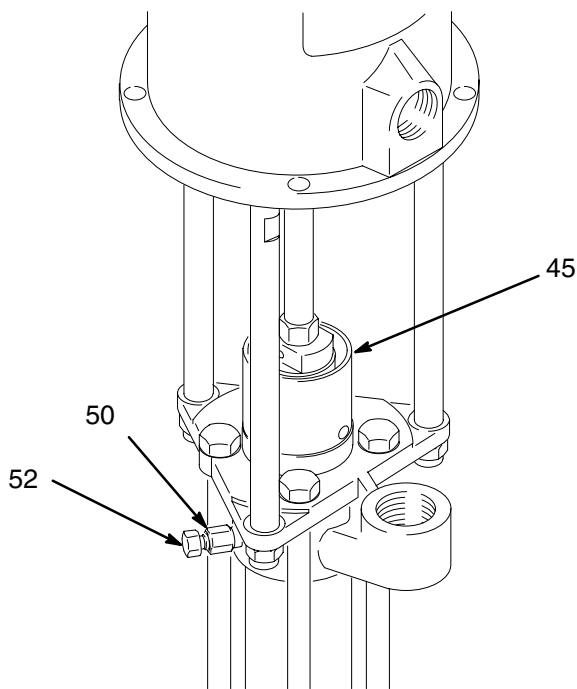

Fig. 3

01560A

Shutdown and Care of the Pump

⚠ WARNING

To reduce the risk of serious injury whenever you are instructed to relieve pressure, always follow the **Pressure Relief Procedure** on page 8.

Relieve the pressure. Whenever you shut off the pump. Stop the pump at the bottom of its stroke to keep fluid from drying on the exposed displacement rod and damaging the throat packings.

Every 40 hours of operation, check that the packing nut/wet cup is tight. **Relieve the pressure** and tighten the nut just snug – do not overtighten, or the packings may be damaged.

Always flush the pump before the fluid dries in the pump and hoses. If the pump is to be stored for any period of time, and you are pumping water-based fluid, first flush the pump with water, then with mineral spirits to protect the pump parts.

Never allow the pump to run dry of the fluid being pumped. A dry pump will quickly accelerate to a high speed, possibly damaging itself. If your pump accelerates quickly, or is running too fast, stop it immediately and check the fluid supply. If the supply container is empty and air has been pumped into the lines, prime the pump and the lines with fluid, or flush the pump and leave it filled with a compatible solvent. Be sure to eliminate all air from the fluid system.

NOTE: A pump runaway valve (F) can be installed on the air line to automatically shut off the pump if it starts to run too fast.

Flushing

To reduce the risk of fluid injection injury, static sparking, or splashing in the eyes or on the skin, **relieve the pressure**, and remove the spray tip (spray guns or spray valves only) before flushing. Hold a metal part of the gun/valve firmly to the side of a grounded metal pail and use the lowest possible fluid pressure during flushing.

Lubrication

The accessory air line lubricator (E) provides automatic air motor lubrication. For daily, manual lubrication, disconnect the air supply, place about 15 drops of light machine oil in the pump air inlet, and reconnect the air supply to blow oil into the motor.

Troubleshooting

WARNING

To reduce the risk of serious injury whenever you are instructed to relieve pressure, always follow the **Pressure Relief Procedure** on page 8.

Before servicing this equipment, always make sure to **relieve the pressure**.

NOTE: Check all possible problems and solutions before disassembling the pump.

Problem	Cause	Solution
Pump fails to operate	Exhausted fluid supply	Refill and reprime or flush
	Restricted line or inadequate air supply	Clear line; see Technical Data on page 19
	Insufficient air pressure; closed or clogged air valve, etc.	Open; clear
	Obstructed fluid hose or gun	Clear*
	Dried fluid built up on the displacement rod.	Clean; see Service on page 11
	Dirty or worn motor parts	Clean; service, see manual 307049 and 309347
Pump operates, but output is low on both strokes	Exhausted fluid supply	Refill and reprime or flush
	Restricted line or inadequate air supply	Clear line; See Technical Data on page 19
	Insufficient air pressure; closed or clogged air valve, etc.	Open, clear
	Obstructed fluid hose or gun	Clear*
	Open or worn bleeder valve	Close; replace
	Air leaking into fluid pressure chamber	Check inductor on ram plate, seal, etc.
	Fluid too heavy for pump to prime	Use bleeder valve (see Operation on page 8). Use inductor or ram unit
	Worn throat packings in displacement pump	Clear; service
Pump operates, but output low on down stroke	Fluid too heavy for pump to prime	Use bleeder valve (see Operation on page 8). Use inductor or ram unit
	Held open or worn intake valve	Clear, service
Pump operates but output low on up stroke	Held open or worn piston valve or packings	Clear; service
Erratic or accelerated pump speed	Exhausted fluid supply	Refill and reprime or flush
	Fluid too heavy for pump to prime	Use bleeder valve (See Operation on page 8). Use inductor or ram unit
	Held open or worn piston valve or packings	Clear; service
	Held open or worn intake valve	Clear; service
	Worn throat packings in displacement pump	Clear; service

* **Relieve the pressure** and disconnect the fluid hose. If the pump starts when the air is turned on, the hose, spray gun, or dispensing valve is clogged

Service

WARNING

To reduce the risk of serious injury whenever you are instructed to relieve pressure, always follow the **Pressure Relief Procedure** on page 8.

WARNING



MOVING PARTS HAZARD

Moving parts can pinch or amputate your fingers or other body parts. When the pump is operating, the priming piston (located at the pump intake) and the air motor piston (located behind the air motor shield) move. Therefore, never operate the pump with the air motor shield removed, and keep your fingers and hands away from the priming piston.

Before attempting to clear an obstruction from the priming piston or service the pump, **relieve the pressure** to prevent the pump from starting accidentally.

Before You Start

1. Repair Kit 220862 is available. For best results, use all the new parts in the kit. Kit parts are indicated in the text and the parts list with an asterisk, for example (22*).
2. To reduce down time, keep spare parts on hand. Recommended spare parts are indicated in the parts list with a dagger, for example (2†).
3. The intake valve and throat gland/packing stacks (54* and 55*^) are preassembled. Do not disassemble the stacks when you install them.
4. For air motor service and parts information, refer to manual 307049 (Bulldog), 307050 (Bulldog Adjust-a-Stroke), and 306068 (King).
5. If possible, flush the pump before service with a compatible solvent. **Relieve the pressure** and stop the pump at the bottom of its stroke.
6. Disconnect all the hoses. Remove the pump from its mounting and clamp it in a vise.

Disassembly

1. Remove the cotter pin (2). Unscrew the coupling nut (14) and the three tie rod locknuts (5). See Fig. 4. Pull the displacement pump (18) off the air motor.
2. Remove the cotter pin (3), loosen the locknut (7), and unscrew the connecting rod (16) from the displacement rod (27).
3. Insert a 1/4 in. (6 mm) diameter rod in the holes of the packing nut/wet-cup (45), and loosen the packing nut/wet-cup. Push the displacement rod (27) down until the priming piston (48) clears the intake valve housing (25). Remove the nut (21), priming piston (48), valve plate (30), and plate guide (31).
4. Unscrew the four tie bolts (19) and pull the intake valve housing (25) off the pump. Pull the priming rod (28) and displacement rod (27) out of the bottom of the cylinder (29). See Fig. 4. Remove the pin (20) and unscrew the priming rod (28) from the adapter (41).
5. Pull the cylinder (29) down out of the outlet housing (26). Inspect the inner surface of the cylinder and the outer surface of the displacement rod (27) for scratches or scoring, which can cause premature packing wear and leaking. To check, run a finger over the surface or hold the part up to the light at an angle.
6. Disassemble the intake valve (33). See Fig. 4. Clean and inspect all parts, replacing as necessary. Check the intake valve seat (32) for nicks or damage.
7. Unscrew the adapter (41) from the displacement rod (27). Disassemble the piston.
8. Unscrew the packing nut/wet-cup (45). Remove the throat packings from the outlet housing (26).
9. Unscrew the bleeder valve plug (52) completely from the valve body (50). Clean the valve threads and the bleed hole. It is not necessary to remove the valve body from the pump outlet housing (26).
10. Clean and inspect all parts, replacing as necessary.

Service

Reassembly

1. Lubricate the throat gland/packing stack (55^{*}^). Install the gland/packing stack into the outlet housing (26), with the lips of the v-packings facing down. See Detail A of Fig. 4. The gland/packing stack is preassembled. Do not disassemble the stack. Loosely install the packing nut/wet-cup.
2. See Detail B of Fig. 4. Install the two bearings (43^{*}) and the u-cup packing (22^{*}) on the piston (42). Be sure the lips of the u-cup packing are facing up. Install the valve plate (44), piston assembly, and adapter (41) on the displacement rod (27).
3. Install the PTFE gasket (39^{*}) in the outlet housing (26). Screw the priming rod (28) into the adapter (41) and secure with the pin (20). Push the displacement rod (27) and priming rod (28) up into the outlet housing so the top of the displacement rod just protrudes from the packing nut/wet-cup (45). Lubricate the priming rod.
4. Install the cylinder (29) in the outlet housing (26), being careful not to scratch the polished inner surface.
5. See Detail C of Fig. 4. Assemble the intake valve by installing the intake gland/packing stack (54^{*}) in the intake valve seal housing (33). Be sure the lips of the v-packings are facing up. The stack is preassembled. Do not disassemble the stack. Tighten the packing nut (37). Install the valve seat (32) in the intake valve housing (25). Place the intake valve seal housing (33) on the seat.
6. Install the two PTFE gaskets (39^{*}) on the valve guide plate (38) and install the bearing (40^{*}) in the center hole of the plate. Install the plate in the intake valve housing (25).
7. Carefully guide the intake valve housing (25) up over the priming rod (28) and install it on the cylinder (29). Install the four washers (56) on the tie bolts (19) and insert the tie bolts through the outlet housing (26) so they engage the holes in the intake valve housing. Torque the tie bolts oppositely and evenly to 60 ft-lb (81 N•m).
8. Install the valve plate guide (31), valve plate (30), priming piston (48), and nut (21) on the priming rod (28). If necessary, push down on the displacement rod (28) to provide sufficient clearance from the intake valve housing (25).
9. Lubricate the threads of the bleeder valve plug (52). The plug has two sets of threads. Be sure to screw the plug completely into the valve body (50). Torque the plug to 22–28 ft-lb (30–38 N•m).
10. Tighten the packing nut/wet-cup (45) just enough to prevent leakage – no tighter.
11. Screw the connecting rod (16) into the displacement rod (27). Insert the cotter pin (3) and tighten the locknut (7). See Fig. 4.
12. Align the pump outlet on the outlet housing (26) with the optional outlet at the base of the air motor (1). Screw the tie rod locknuts (5) onto the tie rods (15) loosely. Tighten the coupling nut (14) to attach the displacement pump to the motor. Install the cotter pin (2).
13. Set the pump and run it slowly to check for binding. Adjust the tie rods as necessary, then torque the locknuts (5) to 40–50 ft-lb (54–68 N•m).
14. Reconnect the fluid, air, and exhaust lines. Reconnect the ground wire if it was disconnected during service.

Service

- ⚠¹ Torque to 40–50 ft-lb (54–68 N•m)
- ⚠² Torque to 60 ft-lb (81 N•m)
- ⚠³ Lips of v-packings must face down
- ⚠⁴ Lips of v-packings must face up

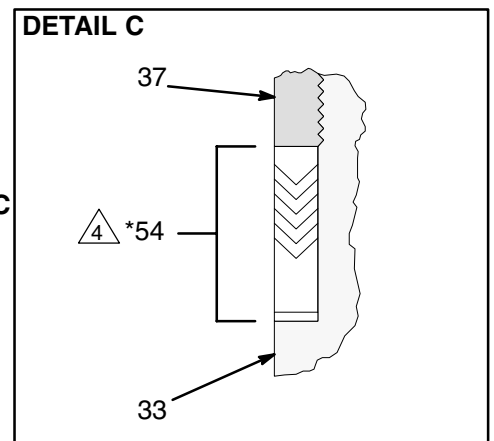
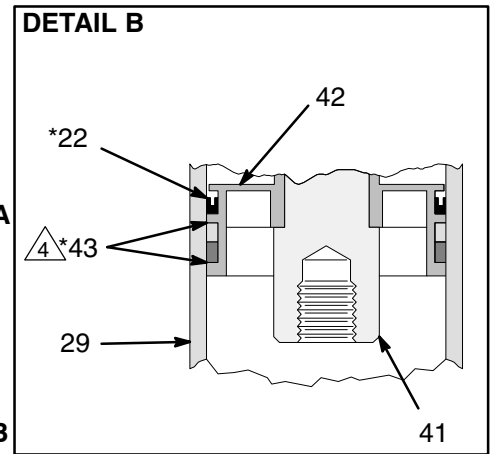
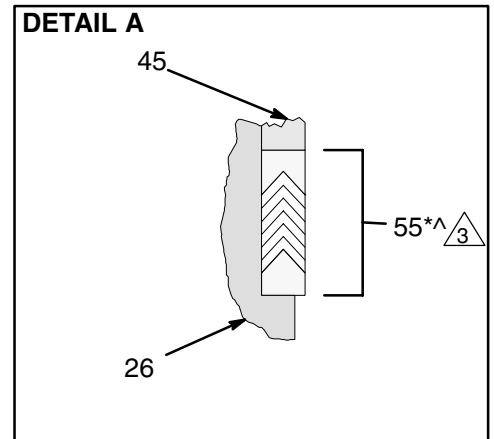
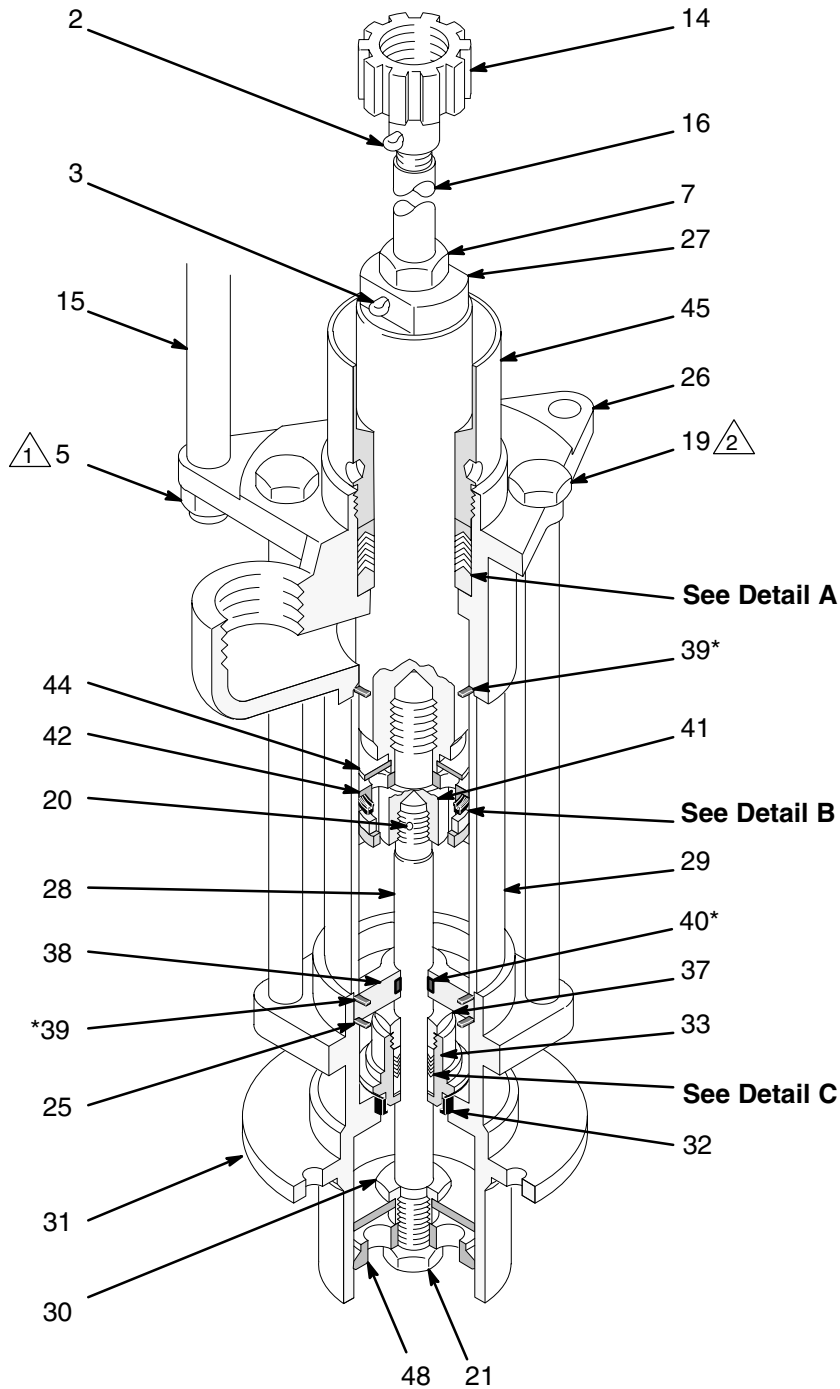

01561

Fig. 4

Parts

Model 954180, Series A
10:1 Ratio Bulldog Sanitary Pump
with Adjust-A-Stroke
 Includes items 1–5

Model 949444, Series A
10:1 Ratio Bulldog Sanitary Pump
 Includes items 1–56

- △1 Torque to 60 ft-lb (81 N•m)
- △2 Torque to 40–50 ft-lb (54–68 N•m)
- △3 Lubricate
- △4 Lubricate Top Threads

- △5 Torque to 22–28 ft-lb (30–38 N•m)
- △6 Lips of V-Packings Must Face Down
- △7 Torque to 40–50 ft-lb (54–68 N•m)
- △8 Lips of V-Packings Must Face Up

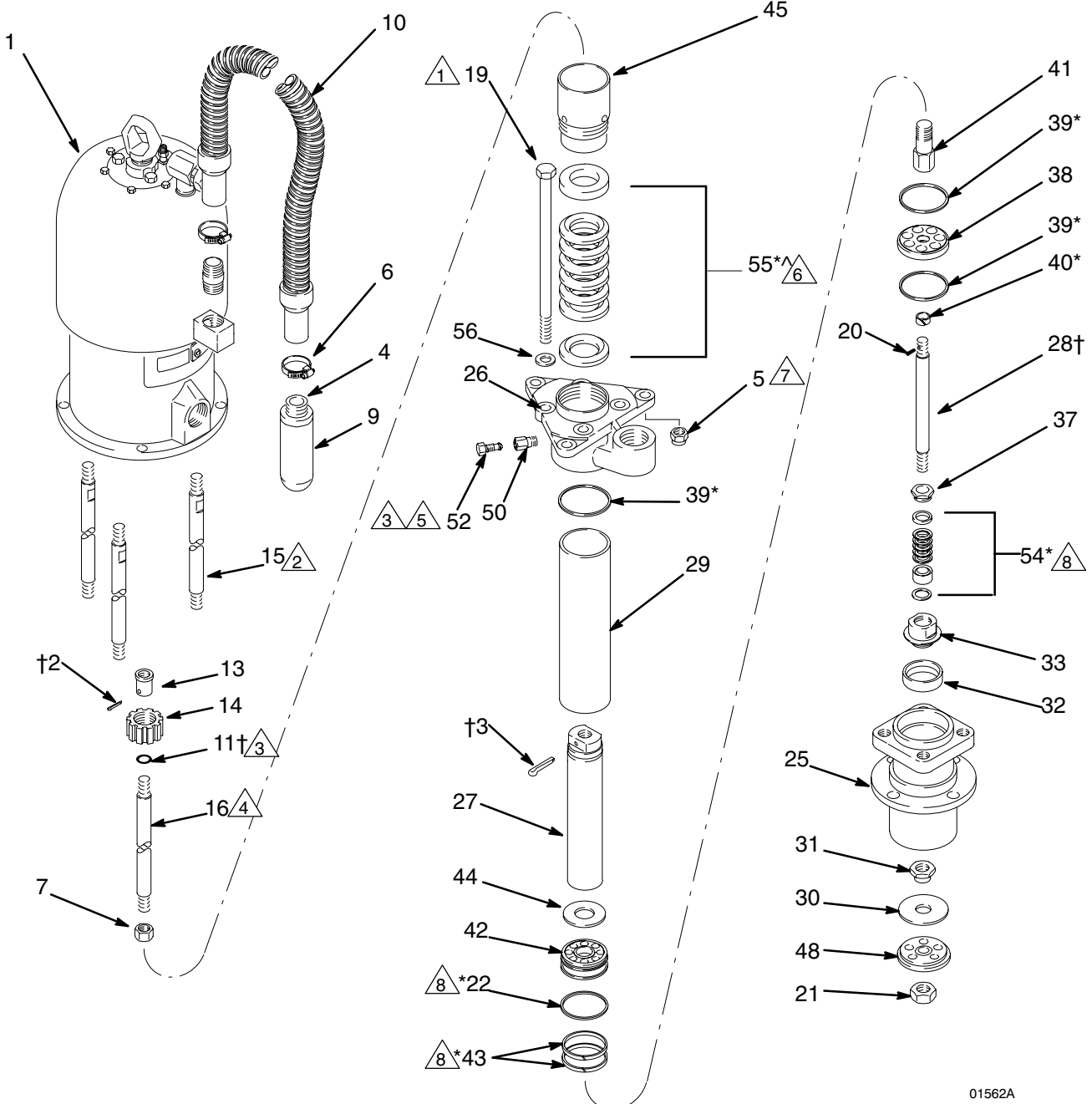

01562A

Parts

Model 949444, Series A
10:1 Ratio Bulldog Sanitary Pump
 Includes items 1–56

Model 954180, Series A
10:1 Ratio Bulldog Sanitary Pump with Adjust–A–Stroke
 Includes items 1–56

Ref. No.	Part No.	Description	Qty.	Ref. No.	Part No.	Description	Qty.
1	625794	SANITARY BULLDOG AIR MOTOR See manual 307049 for parts (949444)	1	19	102215	. SCREW, hex hd cap; 5/8–11 x 12" (305 mm) long	4
	946247	SANITARY BULLDOG AIR MOTOR with Adjust–A–Stroke See manual 307050 for parts (954180)	1	20	102532	. PIN, spring; sst	1
				21	102533	. NUT, hex jam; 5/8–18; sst	1
				22*	108543	. PACKING, u-cup; UHMWPE	1
				25	167473	. HOUSING, intake valve; sst	1
				26	167474	. HOUSING, outlet, sst	1
2†	101946	PIN, cotter; 0.120" (3 mm) dia. x 1.5" (38 mm) long (949444)	2	27	167475	. ROD, displacement; sst	1
	100103	PIN, cotter; 0.125" (3.2 mm) dia. x 1.5" (38 mm) long (954180)	1	28†	167476	. ROD, priming; sst	1
				29	167477	. CYLINDER, pump; sst	1
3†	100104	PIN, cotter; 0.125" (3.2 mm) dia. x 1.75" (45 mm) long (954180 only)	1	30	167479	. PLATE, valve; sst	1
				31	167480	. GUIDE, valve plate; sst	1
4	503857	NIPPLE, pipe; 1" npt	1	32	167481	. SEAT, valve; sst	1
5	102216	NUT, lock; 5/8–11; w/nylon insert (949444)	3	33	167482	. HOUSING, intake valve seal	1
	101712	NUT, lock; 5/8–11; w/nylon insert (954180)	3	37	167486	. NUT, packing; sst	1
				38	167487	. PLATE, guide; sst	1
6	101818	CLAMP, hose; for 13/16" to 1–1/2" OD hose; sst	2	39*	167488	. GASKET, flat; PTFE	3
				40*	167489	. BEARING, shaft; PTFE	1
7	102217	NUT, hex, jam; 3/4" (949444)	1	41	167490	. ADAPTER; 3/4–10 unc x 1"–14 nf; sst	1
	101936	NUT, hex, jam; 3/4" (954180)	1	42	181892	. PISTON; sst	1
9	512914	MUFFLER	1	43*	181897	. BEARING, piston; acetal	2
10	102810	HOSE, flexible; vinyl; 1–1/4" ID; 6 ft. (1.83 m) long	1	44	167493	. PLATE, valve; sst	1
				45	181895	. NUT, packing, w/wet-cup; sst	1
11†	158674	O-RING, nitrile rubber (949444 only)	1	48	172200	. PISTON, priming; sst	1
				50	184392	. HOUSING, bleeder valve	1
13	166048	COUPLING, connecting rod (949444)	1	52	190293	. PLUG, bleeder valve	1
	161543	COUPLING, connecting rod (954180)	1	54*	223543	. GLAND/PACKING STACK, intake; PTFE, acetal, sst	1
				55*^	223544	. GLAND/PACKING STACK, throat; PTFE, acetal, sst	1
14	161544	NUT, swivel (949444)	1	56	111477	. WASHER; 0.640"; sst	4
	161544	NUT, shouldered (954180)	1				
15	624858	ROD, tie; 14" (356 mm) long, shoulder to shoulder (949444)	3				
	168824	ROD, tie; 13–7/8" (352.4 mm) long, shoulder to shoulder (954180)	3				
16	625904	ROD, connecting (949444)	1				
	168054	ROD, connecting (954180)	1				
18	207242	DISPLACEMENT PUMP ASSEMBLY, Series E Includes items 19–56	1				

* Included in Repair Kit 220862.

† Recommended Tool Box spare parts. Keep these spare parts on hand to reduce down time.

^ Alternate U–cup based throat packing stack 119354; Acetal, UHMWPE, FDA nitrile.

Parts

Model 220648, Series B
20:1 Ratio King Pump
 Includes items 1–56

- △1 Torque to 60 ft-lb (81 N•m)
- △2 Torque to 40–50 ft-lb (54–68 N•m)
- △3 Lubricate
- △4 Lubricate Top Threads

- △5 Torque to 22–28 ft-lb (30–38 N•m)
- △6 Lips of V-Packings Must Face Down
- △7 Torque to 40–50 ft-lb (54–68 N•m)
- △8 Lips of V-Packings Must Face Up

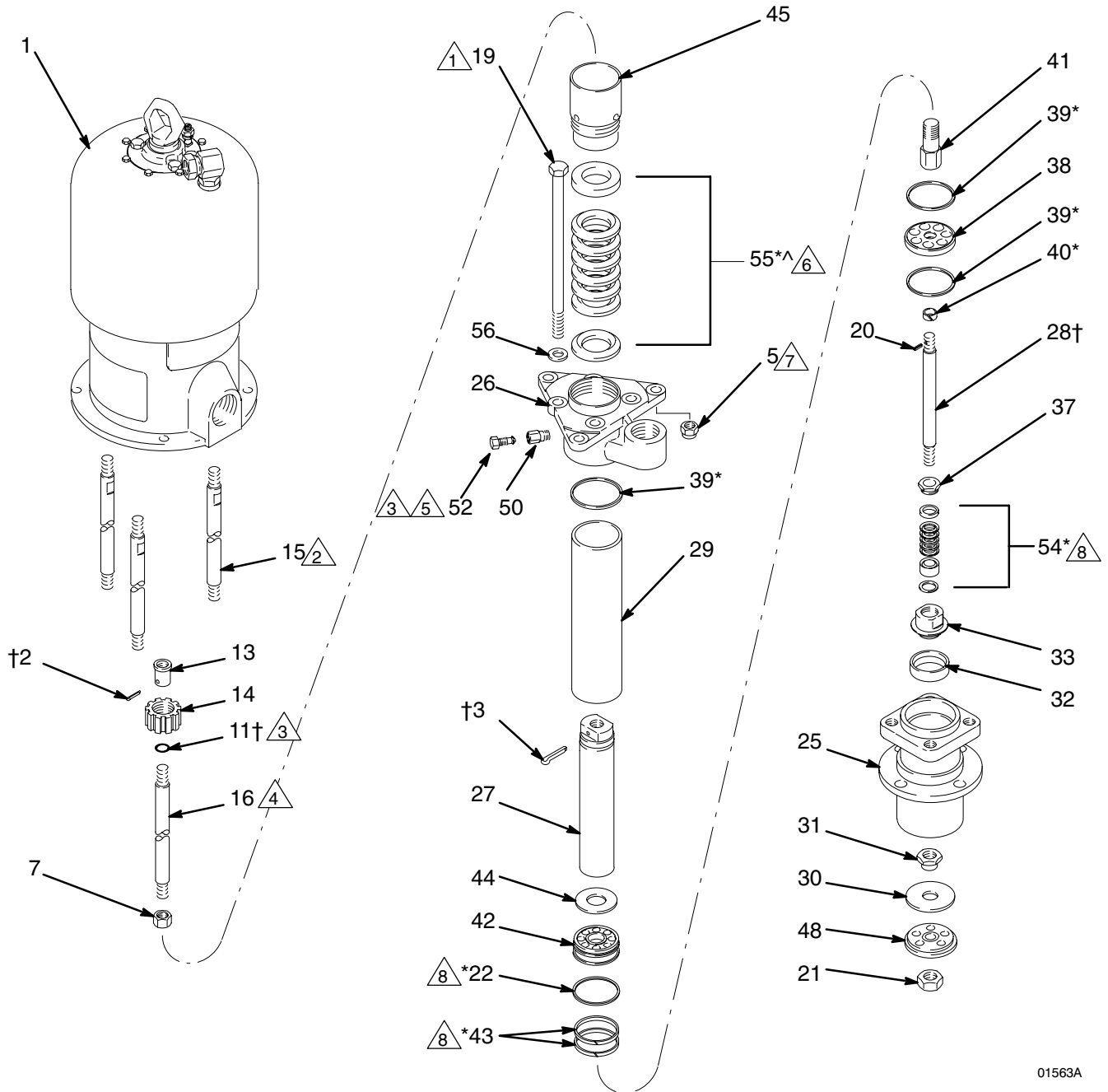

01563A

Parts

Model 220648, Series B

20:1 Ratio King Pump

Includes items 1–56

Ref. No.	Part No.	Description	Qty.	Ref. No.	Part No.	Description	Qty.
1	245111	KING AIR MOTOR See 309347 for parts	1	31	167480	. GUIDE, valve plate; sst	1
2†	100103	PIN, cotter; 0.125" (3.2 mm) dia. x 1.5" (38 mm) long	1	32	167481	. SEAT, valve; sst	1
3†	100104	PIN, cotter; 0.125" (3.2 mm) dia. x 1.75" (45 mm) long	1	33	167482	. HOUSING, intake valve seal; sst	1
5	101712	NUT, lock; 5/8–11; w/nylon insert	3	37	167486	. NUT, packing; sst	1
7	101936	NUT, hex, jam; 3/4"	1	38	167487	. PLATE, guide; sst	1
11†	158674	O-RING, nitrile rubber	1	39*	167488	. GASKET, flat; PTFE	3
14	168210	NUT, shouldered	1	40*	167489	. BEARING, shaft; PTFE	1
15	168824	ROD, tie; 13–7/8" (352.4 mm) long, shoulder to shoulder	3	41	167490	. ADAPTER; 3/4–10 unc x 1"–14 nf; sst	1
16	168253	ROD, connecting; 9–5/16" (236.5 mm) long	1	42	181892	. PISTON, sst	1
18	207242	DISPLACEMENT PUMP ASSEMBLY, Series E Includes items 19–56	1	43*	181897	. BEARING, piston; acetal	2
19	102215	. SCREW, hex hd cap; 5/8–11 x 12" (305 mm) long	4	44	167493	. PLATE, valve; sst	1
20	102532	. PIN, spring; sst	1	45	181895	. NUT, packing, w/wet-cup; sst	1
21	102533	. NUT, hex, jam; 5/8–18; sst	1	48	172200	. PISTON, priming, sst	1
22*	108543	. PACKING, u-cup; UHMWPE	1	50	184392	. HOUSING, bleeder valve	1
25	167473	. HOUSING, intake valve; sst	1	52	190293	. PLUG, bleeder valve	1
26	167474	. HOUSING, outlet; sst	1	54*	223543	. GLAND/PACKING STACK, intake; PTFE, acetal, sst	1
27	167475	. ROD, displacement; sst	1	55*^	223544	. GLAND/PACKING STACK, throat; PTFE, acetal, sst	1
28†	167476	. ROD, priming; sst	1	56	111477	. WASHER; 0.640"; sst	4
29	167477	. CYLINDER, pump; sst	1				
30	167479	. PLATE, valve; sst	1				

* Included in Repair Kit 220862.

† Recommended Tool Box spare parts. Keep these spare parts on hand to reduce down time.

^ Alternate U-cup based throat packing stack 119354; Acetal, UHMWPE, FDA nitrile.

Dimensions

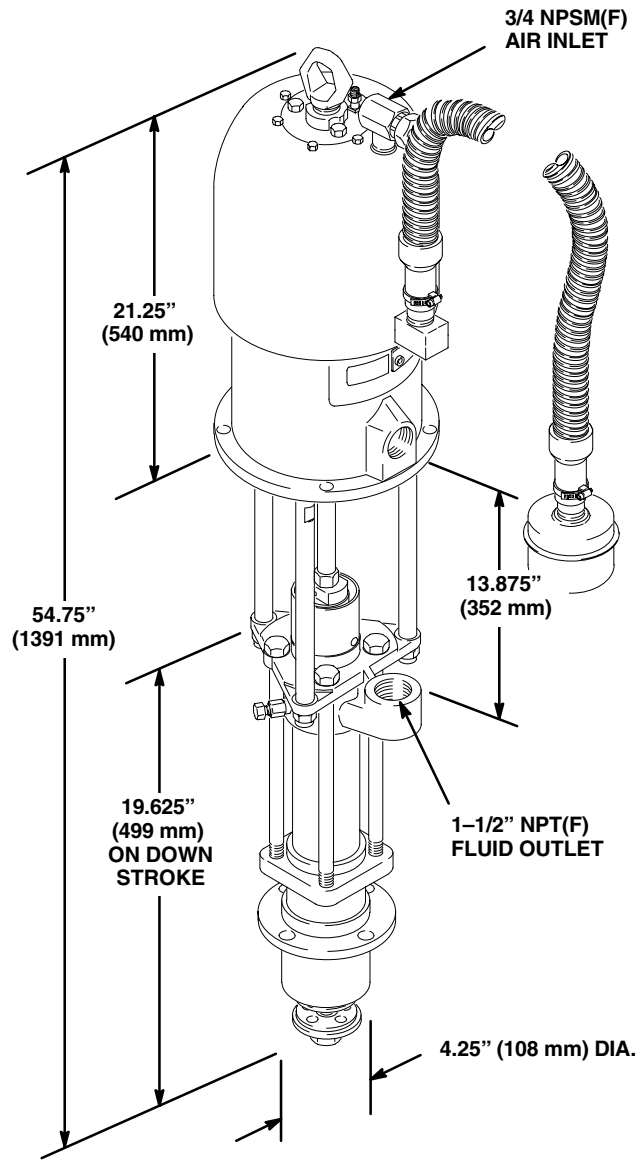

01564A

Air Motor Mounting Pump Intake Mounting

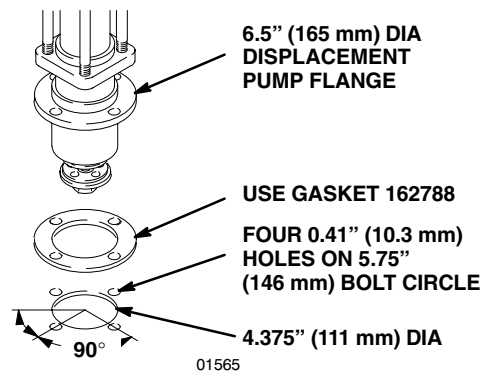
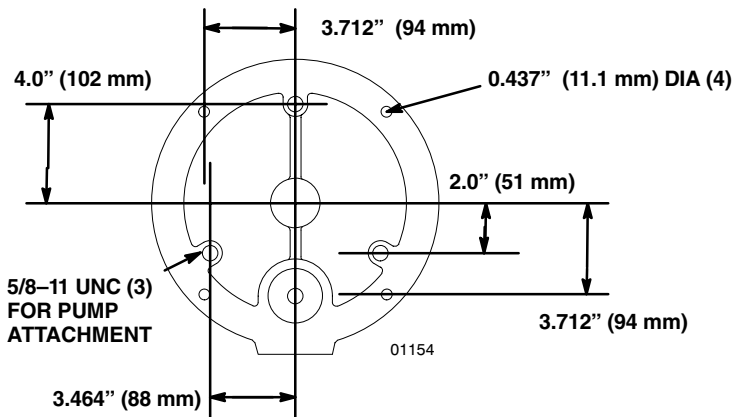

Technical Data

Category	Data
Air Operating Range	Models 949444 and 954180: 40–100 psi (3–7 bar, 0.3–0.7 MPa) Model 220648: 40–90 psi (3–6 bar, 0.3–0.6 MPa)
Air Consumption	13 cfm per gallon pumped (0.10 m ³ /min/liter) at 100 psi (7 bar, 0.7 MPa) air pressure; up to 120 cfm (3.4 m ³ /min/liter) with pump operated within recommended range
Pump Cycles Per Gallon (liter)	7 (26.6)
Maximum Recommended Pump Speed	60 cycles/min; 8.5 gpm (32 liter/min) delivery
Maximum Pump Discharge Pressure	Models 949444 and 954180: 1000 psi (70 bar, 7 MPa) Model 220648: 1800 psi (124 bar, 12 MPa)
Wetted Parts	302, 303, and 304 grade Stainless Steel, PTFE, Delrin [®] , Acetal, Ultra-High Molecular Weight Polyethylene
Weight	101 lb (46 kg)

Delrin[®] and Viton[®] are registered trademarks of the DuPont Co.

Sound Pressure Levels (dBa) (measured at 1 meter from unit)

Air Motor	Input Air Pressures at 15 cycles per minute			
	0.28 MPa, 2.8 bar (40 psi)	0.48 MPa, 4.8 bar (70 psi)	0.6 MPa, 6 bar (90 psi)	0.7 MPa, 7 bar (100 psi)
King	78.8 dB(A)	82.7 dB(A)	90.5 dB(A)	not applicable
Bulldog	82.4 dB(A)	87.3 dB(A)	88.5 dB(A)	90.0 dB(A)

Sound Power Levels (dBa) (tested in accordance with ISO 9614–2)

Air Motor	Input Air Pressures at 15 cycles per minute			
	0.28 MPa, 2.8 bar (40 psi)	0.48 MPa, 4.8 bar (70 psi)	0.6 MPa, 6 bar (90 psi)	0.7 MPa, 7 bar (100 psi)
King	86.5 dB(A)	88.8 dB(A)	97.7 dB(A)	not applicable
Bulldog	91.6 dB(A)	95.9 dB(A)	97.4 dB(A)	98.1 dB(A)

The Graco Standard Warranty

Graco warrants all equipment manufactured by Graco and bearing its name to be free from defects in material and workmanship on the date of sale to the original purchaser for use. With the exception of any special, extended, or limited warranty published by Graco, Graco will, for a period of twelve months from the date of sale, repair or replace any part of the equipment determined by Graco to be defective. This warranty applies only when the equipment is installed, operated and maintained in accordance with Graco's written recommendations.

This warranty does not cover, and Graco shall not be liable for general wear and tear, or any malfunction, damage or wear caused by faulty installation, misapplication, abrasion, corrosion, inadequate or improper maintenance, negligence, accident, tampering, or substitution of non-Graco component parts. Nor shall Graco be liable for malfunction, damage or wear caused by the incompatibility of Graco equipment with structures, accessories, equipment or materials not supplied by Graco, or the improper design, manufacture, installation, operation or maintenance of structures, accessories, equipment or materials not supplied by Graco.

This warranty is conditioned upon the prepaid return of the equipment claimed to be defective to an authorized Graco distributor for verification of the claimed defect. If the claimed defect is verified, Graco will repair or replace free of charge any defective parts. The equipment will be returned to the original purchaser transportation prepaid. If inspection of the equipment does not disclose any defect in material or workmanship, repairs will be made at a reasonable charge, which charges may include the costs of parts, labor, and transportation.

THIS WARRANTY IS EXCLUSIVE, AND IS IN LIEU OF ANY OTHER WARRANTIES, EXPRESS OR IMPLIED, INCLUDING BUT NOT LIMITED TO WARRANTY OF MERCHANTABILITY OR WARRANTY OF FITNESS FOR A PARTICULAR PURPOSE.

Graco's sole obligation and buyer's sole remedy for any breach of warranty shall be as set forth above. The buyer agrees that no other remedy (including, but not limited to, incidental or consequential damages for lost profits, lost sales, injury to person or property, or any other incidental or consequential loss) shall be available. Any action for breach of warranty must be brought within two (2) years of the date of sale.

Graco makes no warranty, and disclaims all implied warranties of merchantability and fitness for a particular purpose in connection with accessories, equipment, materials or components sold but not manufactured by Graco. These items sold, but not manufactured by Graco (such as electric motors, switches, hose, etc.), are subject to the warranty, if any, of their manufacturer. Graco will provide purchaser with reasonable assistance in making any claim for breach of these warranties.

In no event will Graco be liable for indirect, incidental, special or consequential damages resulting from Graco supplying equipment hereunder, or the furnishing, performance, or use of any products or other goods sold hereto, whether due to a breach of contract, breach of warranty, the negligence of Graco, or otherwise.

FOR GRACO CANADA CUSTOMERS

The parties acknowledge that they have required that the present document, as well as all documents, notices and legal proceedings entered into, given or instituted pursuant hereto or relating directly or indirectly hereto, be drawn up in English. Les parties reconnaissent avoir convenu que la rédaction du présente document sera en Anglais, ainsi que tous documents, avis et procédures judiciaires exécutés, donnés ou intentés à la suite de ou en rapport, directement ou indirectement, avec les procédures concernées.

Graco Information

TO PLACE AN ORDER, contact your Graco distributor, or call one of the following numbers to identify the distributor closest to you:

1-800-367-4023 Toll Free

612-623-6921

612-378-3505 Fax

All written and visual data contained in this document reflects the latest product information available at the time of publication. Graco reserves the right to make changes at any time without notice.

Sales Offices: Minneapolis, Detroit
International Offices: Belgium, Korea, Hong Kong, Japan

www.graco.com

PRINTED IN U.S.A. 306916 11/1966, Revised 02/2004