



**TRANE™**

**Installation  
Operation  
Maintenance**

**CGA-IOM-2**

Library	Service Literature
Product Section	Refrigeration
Product	Recip. Liquid Chillers - A/C Cold Generators
Model	CGA
Literature Type	Installation/Operation/Maintenance
Sequence	2
Date	September 1992
File No.	SV-RF-CG-CGA-IOM-2-9/92
Supersedes	New

**10 and 15 ton  
Air-Cooled  
Cold Generators®**

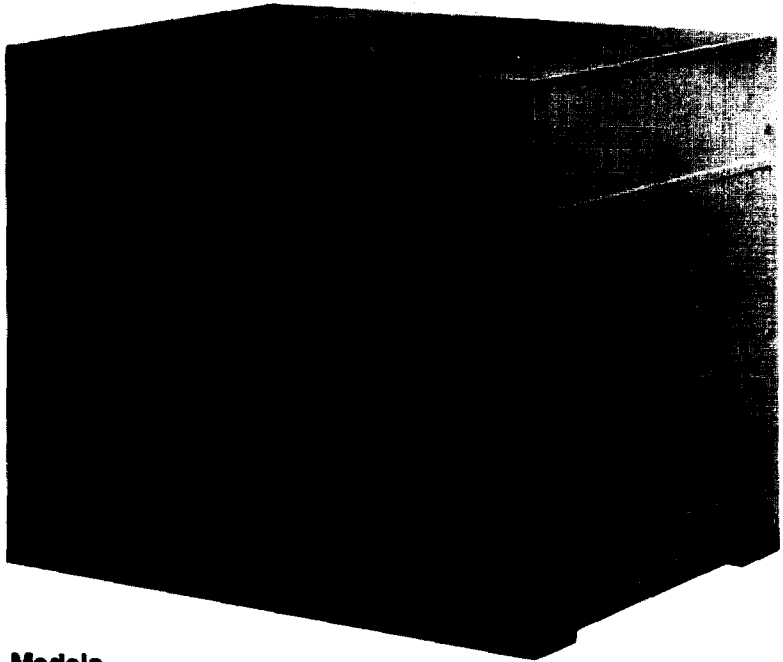

**Models**  
CGA-120B \_ \_ \_ B \_ \_  
CGA-180B \_ \_ \_ B \_ \_  
(Model Number Digit 11 is "B")

**Important Note:**

Do not release refrigerant to the atmosphere!  
If required service procedures include the adding or removing of refrigerant, the service technician must comply with all federal, state, and local laws. Refer to general service bulletin MSCU-SB-1 (latest edition).

Since the Trane Company has a policy of continuous product improvement, it reserves the right to change specifications and design without notice. The installation and servicing of the equipment referred to in this booklet should be done by qualified, experienced technicians.

# Table of Contents

---

<b>3 Unit Model Number Description</b>	<b>17 Operation</b>
<b>4 General Information</b>	17 Start-Up Procedure
4 Literature Change History	17 Checking Operating Conditions
4 "Warnings" and "Cautions"	18 Refrigerant Charge Information
4 Unit Description	18 Temporary Unit Shut-down and Re-start
4 Unit Inspection	18 Extended Unit Shut-down/Winterization
4 Inspection Checklist	19 System Re-start after Extended Shut-down
4 Nameplates	19 Low Ambient Operation
4 —Unit Nameplate	19 —Head Pressure Control
<b>5 Installation</b>	19 Freeze Protection
5 Unit Dimensions and Weights	19 Electrical Control System
5 Handling	19 Unit Safety Controls
5 Drainage	19 —Low pressure Cutout (LPCO1, LPCO2)
5 Rigging	20 —High Pressure Cutout (HPCO1, HPCO2)
5 Location and Clearance Requirements	20 —Reset Relays (RR1, RR2)
5 —Unit Isolation	20 —Low Temperature Cutout (LTC)
8 Unit Water Piping	20 —Motor Overloads
8 —General Piping Recommendations	20 Unit Operational Controls
8 —Evaporator	20 —Water Temperature Thermostat (WTT)
8 —Piping Components	20 —Low Ambient Start Timer (LAST1, LAST2)
8 —Evaporator Drain	20 —Hot Gas Bypass (HGBT, HGBS)
8 —Evaporator Flow Switch	20 —Anti-Short Cycle Timers (ASCT1, ASCT2)
9 Freeze Protection	20 Delay Between Compressors (DBC)
9 —General	21 Unit Control System
9 —Heat Tape Installation	21 —Sequence of operation
12 Electrical Wiring	22 Determining Setpoint for Water Temp T-Stat
12 —General	22 Water Temp T-Stat Operation
12 —CGA Unit Power Supply	24 CGA120 Unit Refrigeration Schematic
12 —Heat Tape Power Supply (For Unit Evaporator)	25 CGA180 Unit Refrigeration Schematic
12 —Heat Tape Power Supply (For Field Installed Piping)	<b>26 Maintenance</b>
12 Interconnecting System Wiring	26 Periodic Maintenance
12 —Chilled Water Pump Motor (CWPM) Power Supply	26 Weekly Maintenance
12 —Flow Switch Interlock	26 Monthly Maintenance
12 Factory Supplied, Field Installed Accessories	26 Annual Maintenance
<b>13 Installation Checklist</b>	26 Maintenance Procedures
<b>14 Pre-Start Procedures</b>	27 —Coil Cleaning
14 Unit Voltage and Amperage Checks	27 —Cleaning Procedure
14 —Voltage Supply	27 —Cleaning the Evaporator
15 —Voltage Imbalance	27 Water Treatment
15 Water System	28 Trouble Analysis
15 —Water Flow Rates	28 Low Ambient Start Timer Checkout Procedure
15 —Pressure Drop Measurement	28 —Preliminary Trouble Inspection
16 —Ethylene Glycol Adjustment Factor	28 —Trouble Shooting Charts
	32 Operator's Maintenance Log

# Unit Model Number Description

All standard Trane products are identified by a multiple-character model number that precisely identifies a particular type of unit. An explanation of the alphanumeric identification codes used for CGA units is provided on this page. Its use will enable the owner/operator, installing contractors, and service engineers to define the operation, components and options for any specific unit.

**CGA 120 B 3 00 B A**  
1 2 3 4 5 6 7 8 9 10 11 12

### Digits 1,2,3

CGA = Cold Generator

### Digits 4,5,6

#### Nominal Capacity (Mbh)

120 = 10 Tons  
180 = 15 Tons

### Digit 7

#### Form or Configuration

(Number of Refrigerant Circuits/  
Number of Compressors)

B = 2 Ref. Ckts/ 2 Comprs.

Unit  
Nameplate

### Digit 8

#### Voltage

1 = 208-230V/60Hz/1\*  
3 = 208-230V/60Hz/3  
4 = 460V/60Hz/3  
W = 575V/60Hz/3  
D = 380-415V/50Hz/3

\* = Not Available on CGA180 Units

### Digits 9

#### Factory Installed Options

O = No Options  
H = Hot Gas Bypass  
C = Chromate Coil  
K = Hot Gas Bypass  
And Chromate Coil

Service  
Data Plate

### Digit 10

#### Expansion Valve

O = Standard Expansion Valve  
V = Low Leaving Solution Temp  
Expansion Valve

### Digit 11

#### Major Design Change

B

### Digit 12

#### Service Digt/Minor Design Change

Figure 1  
(See Note)

AMERICAN STANDARD INC.					
THE TRANE CO.					
MODEL NO.	MFG. DATE				
SERIAL NO.					
UNIT RATED POWER	VOLT	PH	HZ		
MAX. FUSE (AMPS)			MIN. CKT. AMP. (AMPS)		
	VOLT	PH	HZ	RLA	LRA
COMPR MOTOR 1					
COMPR MOTOR 2					
COND FAN MTR (S)	QTY	PH	HZ	FLA	HP
		VOLTS		PH	HZ
POWER REQUIREMENTS FOR EVAPORATOR HEAT TAPE					
FACTORY CHARGED R22 REFRIGERANT		(CKT. 1)		(CKT. 2)	
		LB	OZ	LB	OZ
TEST PRESSURE	PSIG HIGH		PSIG LOW		
SUITABLE FOR OUTDOOR USE					
MAXIMUM CIRCUIT BREAKER SIZE CANADIAN INSTALLATION (CSA) ONLY					AMPS
FT. SMITH, AR. 72903		MADE IN U.S.A.		21C93220P01	

PRODUCT SERVICE DATA			
MODEL NO.	MFG. DATE		
SERIAL NO.			
REFRIGERANT R22 CHARGE	CKT 1	LB	OZ
	CKT 2	LB	OZ

DRG. 21C932220

Note: The unit nameplate is located adjacent to the high voltage access hole near the control panel. The service data plate is located inside the control box.

# General Information

---

## Literature Change History

### CGA-IOM-2 (September 1992)

Original issue of manual covering CGA 10 and 15-ton units of "B" design. (See digit 11)

## Warnings and Cautions

"Warnings" and "Cautions" appear at appropriate points in this manual. Cautions indicate areas where special attention is required to prevent equipment or property damage. Warnings focus attention on the personal safety of installing and operating personnel. The instructions given in each warning that appears in this manual must be followed carefully.

## Installation Checklist

An Installation Checklist is provided at the end of the "Installation" section of this manual. Use the checklist to verify that all necessary installation procedures have been completed. **Do not use the checklist as a substitute for reading the detailed information contained in the manual.** Read the entire manual before beginning installation procedures.

## Unit Description

10 and 15-ton Model CGA air-cooled Cold Generators are designed for outdoor installation with a vertical air discharge. Each refrigerant circuit is provided with an operating charge of refrigerant and refrigerant oil, a filter drier, sight glass/moisture indicator and thermostatic expansion valve. All units are dehydrated, leak tested, charged and tested for proper control operation before shipment.

An access panel(s) provides access to the compressor section(s), and a removable cover allows access to the control box.

A bag containing the installation/operation/maintenance manual and the unit wiring diagrams ships inside the unit control box. Be sure to read this literature **before** installing and operating the unit. Refer to Figures 2 and 3 for unit access panel locations and other exterior components.

## Unit Inspection

When the unit is delivered to the job site, verify that the correct unit has been shipped by comparing the information on the unit nameplate with ordering, submittal and shipping information. Refer to "Nameplates".

Inspect the unit—inside and out—for damage. Rotate the condenser fan(s) to ensure that they turn freely. Report any apparent damage or material shortage to the carrier and make a "unit damage or shortage" notation on the carrier's delivery receipt. Specify the extent and type of damage found, and notify the appropriate Trane sales office. Do not proceed with installation of a damaged unit without sales office approval.

## Inspection Checklist

To protect against loss due to damage incurred in transit, complete the following checklist upon receipt of the unit:

- Inspect individual pieces of the shipment before accepting the unit. Check for obvious damage to the unit or packing material.
- Check the unit for concealed damage before it is stored and as soon as possible after delivery. Concealed damage must be reported within 15 days.
- If concealed damage is discovered, stop unpacking the shipment. Do not remove damaged material from the receiving location. Take photos of the damage, if possible. The owner must provide reasonable evidence that the damage did not occur after delivery.
- Notify the carrier's terminal of damage immediately by phone and by mail. Request an immediate joint inspection of the damage by the carrier and the consignee.
- Notify the Trane sales representative and arrange for repair. Do not repair the unit, however, until damage is inspected by the carrier's representative.

## Nameplates

The nameplates on these machines provide valuable information pertaining to the identification of the unit and its components. Be sure to provide all pertinent nameplate data when ordering parts or literature, and when making other inquiries.

## Unit Nameplate

The CGA unit nameplate is mounted on the front of the unit, at the compressor end. This nameplate (shown in Figure 1) specifies unit model number, serial number, electrical characteristics, heat tape power requirements and refrigerant charge information.

# Installation

Complete the "Installation Checklist" during installation to verify completion of all recommended procedures before unit start-up.

## Unit Dimensions and Weights

CGA-10 and -15 unit dimensions and weights are provided in Figures 2 and 3 and Table 1.

## Handling

Each CGA unit is banded to a shipping skid for shipment to the job site. Move the unit using a forklift of suitable capacity. See Table 1 for unit shipping weights.

**WARNING: TO AVOID POSSIBLE INJURY OR UNIT DAMAGE, DO NOT REMOVE THE UNIT FROM ITS SHIPPING SKID UNTIL IT IS AT THE INSTALLATION SITE.**

## Drainage

Locate the unit near a large-capacity drain to allow system drainage during unit shutdown and repair.

## Rigging

Use a forklift, crane or helicopter of suitable capacity to move the unit to its mounting location. Unit shipping weights are provided in Table 1.

**Table 1  
Unit Weights**

Model No.	Aprox. Corner weight (lbs) 1				Max. Unit Shipping Weight
	#1	#2	#3	#4	
CGA120B	187	180	116	112	657
CGA180B	222	223	205	204	942

Note 1 Corner weights include weight of water in the evaporator.

**WARNING: TO AVOID POSSIBLE INJURY, DEATH AND EQUIPMENT DAMAGE, ENSURE THAT ON-SITE LIFTING EQUIPMENT IS CAPABLE OF HANDLING UNIT WEIGHT.**

Rig the unit using either belt or cable slings. Fasten the slings to the unit at the four holes provided in the unit's base. Use spreaders to protect the top of the unit when it is lifted. The point at which the slings meet at the lifting hook must be at least 6 feet above the unit. Test-lift the unit to ensure proper balance and rigging.

**WARNING: TO PREVENT INJURY, DEATH OR EQUIPMENT DAMAGE, USE CABLES STRONG ENOUGH TO SUPPORT UNIT WEIGHT. TEST-LIFT UNIT TO ENSURE PROPER BALANCE AND RIGGING.**

## Location and Clearance Requirements

Select an installation site where air will flow upward, unobstructed, through the condenser coil and away from the fan discharge. Protect the unit's condenser intakes from crosswinds exceeding 5 mph. Position the unit above the snowline, and above the path of any windblown debris. Refer to Figures 2 and 3 for clearances.

**CAUTION: Do not install the unit under an overhang, since obstructing vertical air discharge will cause recirculation of warm air.**

If the unit is installed in a well or pit, the height of the pit walls must not exceed the height of the unit; the normal condenser air clearances must be doubled as well. In those applications where multiple units are installed, the minimum distance between each unit is 6 feet, (entire perimeter).

## Unit Isolation

Mounting methods that will minimize sound and vibration problems are:

1. Mount the unit directly on an isolated concrete pad or on isolated concrete footings at each unit mounting point.
2. Install the optional neoprene or spring isolators at each mounting location. Refer to the appropriate isolator installer's guide for installation.

**Figure 2**  
**CGA120B Unit**  
**(10 Ton)**

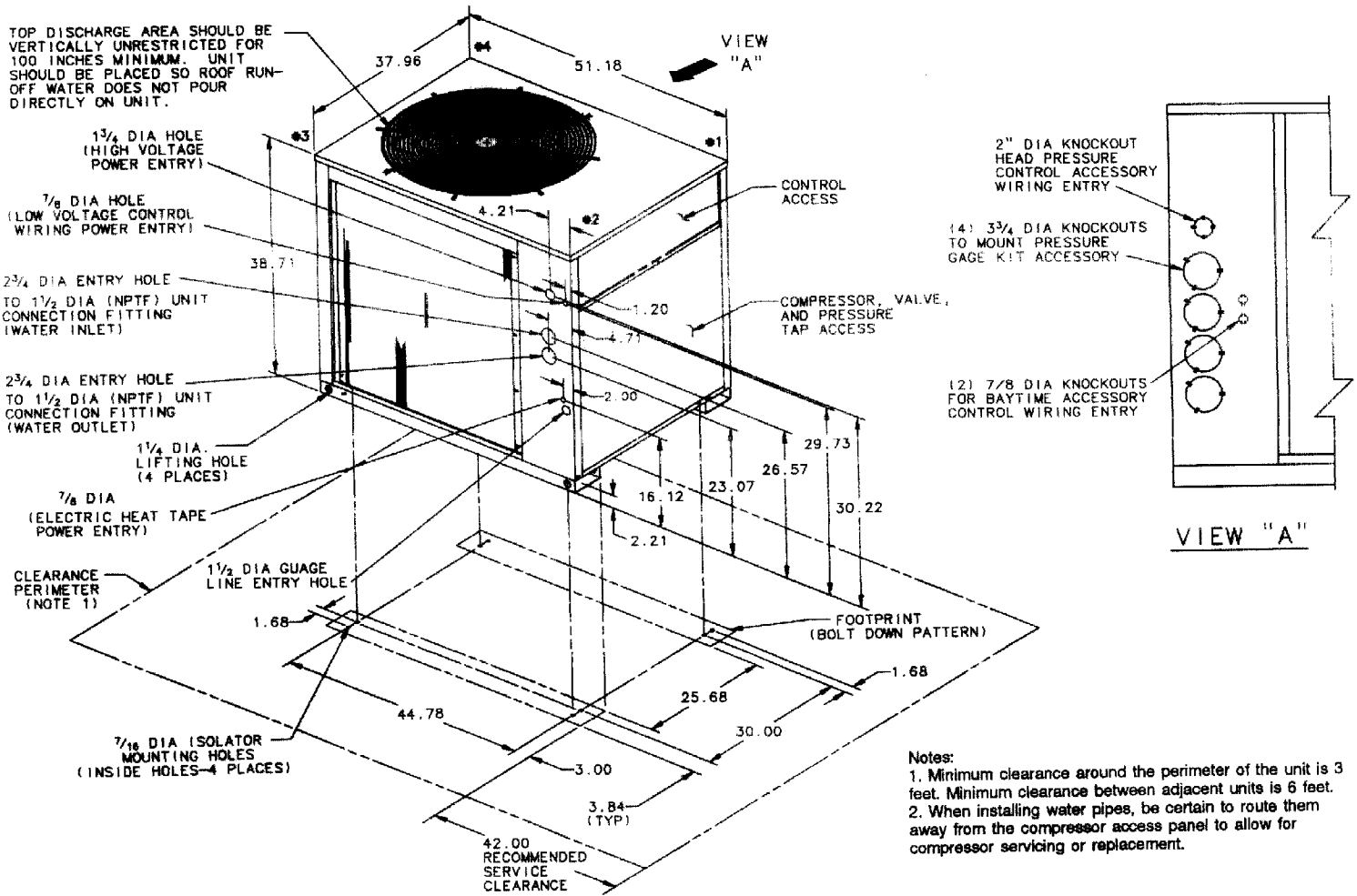

Drg. 21C681359

**Figure 3**  
**CGA180B Unit**  
**(15 Ton)**

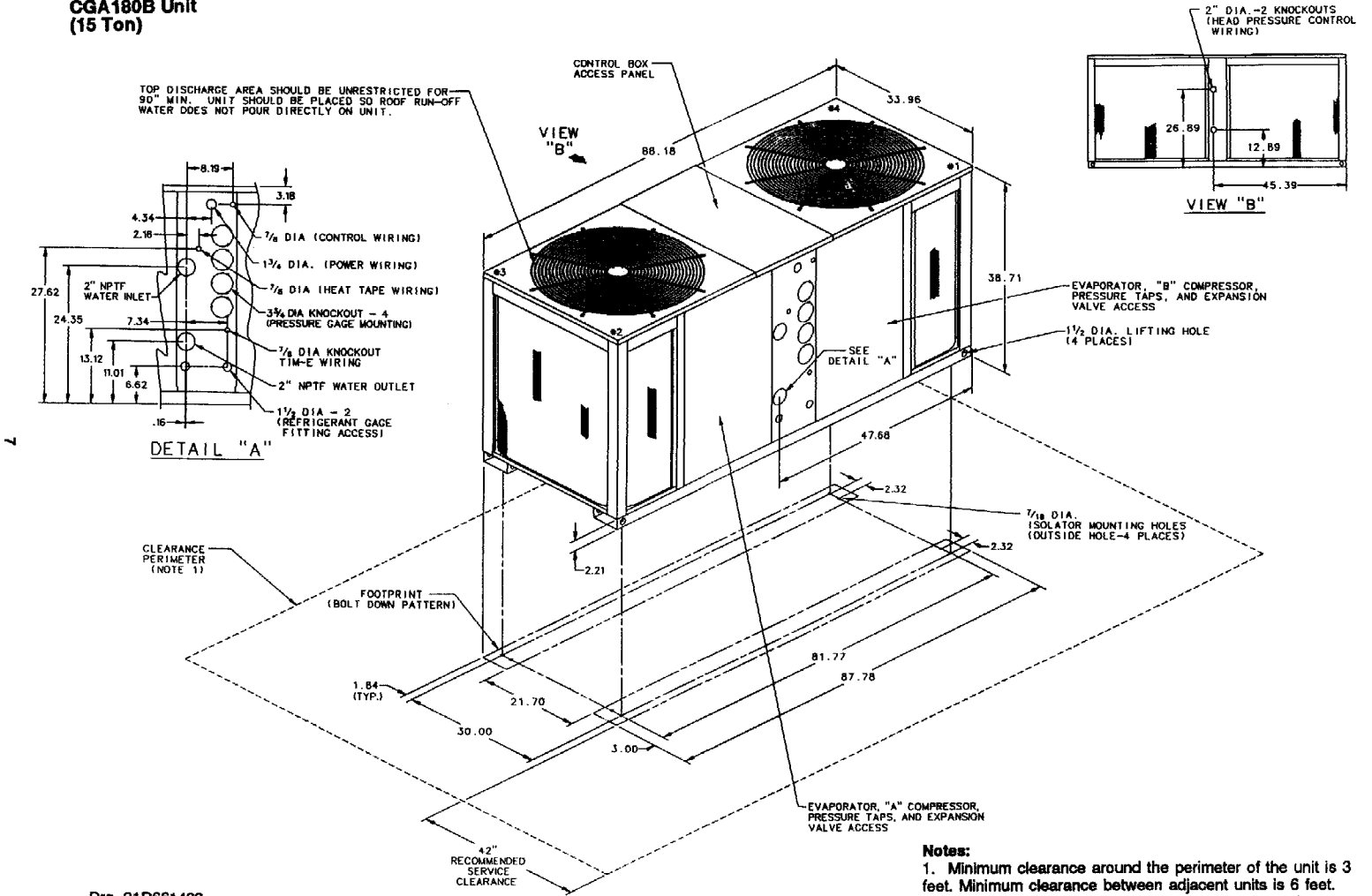

Drg. 21D661492

**Notes:**

1. Minimum clearance around the perimeter of the unit is 3 feet. Minimum clearance between adjacent units is 6 feet.
2. When installing water pipes, be certain to route them away from the compressor access panels to allow for compressor servicing or replacement.

## Unit Water Piping

### General Piping Recommendations

Thoroughly flush all water supply piping **before** making the final piping connections to the unit.

**CAUTION:** If using an acidic commercial flushing solution, construct a temporary bypass around the unit to prevent damage to the evaporator's internal components.

**CAUTION:** To avoid possible equipment damage, do not use untreated—or improperly treated—system water.

Refer to the "Trane Reciprocating Refrigeration Manual" for a complete discussion of proper piping practices and sizing methods. This manual is available through local Trane sales offices.

### Evaporator Water Piping

The unit's water connection sizes and locations are shown in Figures 2 and 3.

**CAUTION:** To prevent unit damage, do NOT reverse system water piping connections to the unit; water entering the evaporator must enter at the designated "Water Inlet", and leaving water must exit the evaporator through the designated Water Outlet "Outlet" connection.

### Piping Components

Figure 4 illustrates typical evaporator piping components. Components and layout will vary slightly depending upon the locations of the connections and water source.

**Figure 4**  
**Recommended Piping Components**  
**For Typical Evaporator Installation**  
(10 ton unit shown)

**Important!**  
When installing water pipes, be certain to route them away from the compressor access panels to allow for compressor servicing or replacement.

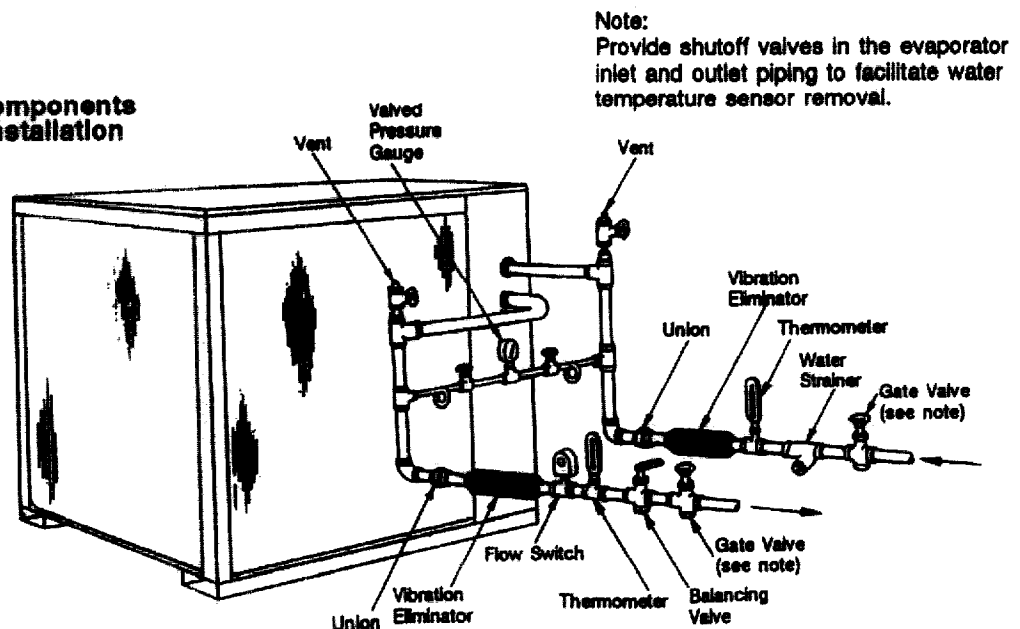

Provide vents at high points in the piping to bleed air from the chilled water system. Install pressure gauge(s) to monitor entering and leaving chilled water pressure.

**CAUTION:** To prevent damage to waterside components, do not allow evaporator pressure to exceed 350 psig (i.e., maximum working pressure).

Provide shutoff valves in the water line(s) to the gauge(s)—as shown in Figure 4—to isolate them from the rest of the system when they are not in use. Use pipe unions to simplify disassembly for system service, and vibration eliminators to prevent vibration transmission through the water lines.

Install thermometers in the lines to monitor evaporator entering and leaving water temperatures, and a balancing cock in the leaving water line to establish a balanced water flow. Install shutoff valves in both the entering and leaving water lines to isolate the evaporator for service.

To protect components from water-borne debris, install a pipe strainer in the evaporator supply line.

### Evaporator Drain

The 1/2 inch NPT drain plug is located in the leaving water tee near the bottom of the evaporator. See "Extended Unit Shutdown/Winterization" on page 18 for draining instructions.

**Note:** If the system has been drained for shutdown, do not energize heat tapes.

### Evaporator Flow Switch

Use of a flow sensing device such as a flow switch is required to prevent or stop compressor operation if the evaporator water flow drops off dramatically. Refer to unit schematic and to the flow switch installation instructions when installing this device.



## Freeze Protection

### General

Use the procedure described below to ensure that the chilled water system is adequately protected from freeze-up in those applications where the unit remains operational at subfreezing ambient temperatures.

1. Install chilled water piping heat tape along with a fused disconnect switch, refer to the instructions outlined under "Heat Tape Installation". Ensure that all exposed piping is adequately protected.

**Note:** Heat tape is factory-installed on the unit evaporator. This heat tape will protect the evaporator from freeze-up at ambient temperatures down to -20 deg F when used in conjunction with properly applied heat tape on the field-installed water lines. Heat tape power draw is 84 watts on CGA180 units and 126 watts on CGA120 units.

2. Freeze-proof the chilled water system by adding a non-freezing, low-temperature, heat-transfer fluid to the chilled water system. Provide protection against ice formation at 10 F below the lowest expected ambient temperature.

**Note:** Use of an ethylene glycol-type antifreeze reduces unit cooling capacity; this condition must be accounted for during total system design. (Refer to "Ethylene Glycol Adjustment Factor" on page 16).

### Heat Tape Installation

Install heat tape on all water piping that may be exposed to freezing temperatures. Be sure to use heat tape that is recommended for low-temperature applications; it should be rated at 110/120 volts, thermostatically-controlled, and dissipate 6 to 7 watts per linear foot.

Heat tape selection should be based on the lowest expected ambient temperature—including any wind chill factor. For those tapes not automatically (i.e., thermostatically) controlled, be sure to install an accessory thermostat.

Refer to Tables 2 and 3 for typical heat tape characteristics.

To install the heat tape properly, follow the instructions provided by the heat tape manufacturer. If none are provided, use the recommendations outlined below:

1. Wrap the heat tape around the pipe—or apply it straight along the pipe—as necessary to provide the required protection. (See Tables 2 and 3)
2. Use friction tape to secure the heat tape to the water pipe.
3. Place the thermostat tightly against—and parallel to the water pipe, then tape it into place at both ends. Be sure to install the thermostat on the most exposed (i.e., coldest) portion of the pipe.
4. Wrap the pipe with weatherproof tape. On vertical pipe runs, start the wrap at the bottom and work up as shown in Figure 5. Be sure to overlap the tape so that it will shed moisture.

**Note:** If additional protection is required, insulate the pipe with fiberglass wrap before installing the outer wrap.

**CAUTION:** To prevent excessive heat generation, resulting in electrical failure of the tape, frozen pipes, and unit damage, do not install fiberglass insulation under the outer wrap when using non-thermostatically-controlled heat tape.

If freezing is a potential problem, all exposed piping, pumps and other components must be similarly protected with heat tape and insulation.

**Figure 5**  
Typical Insulated Heat Tape Installation (Spiralled Application)

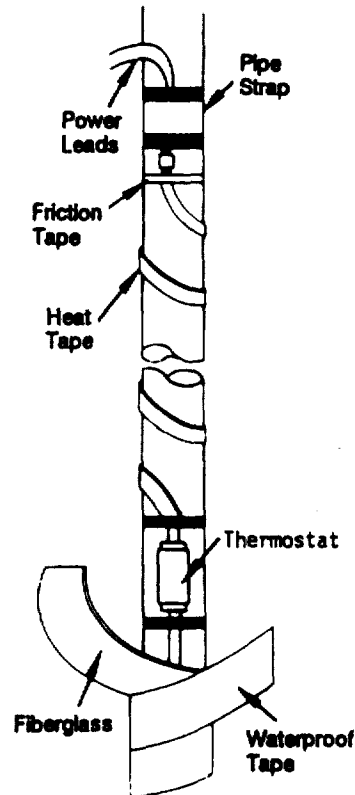

**Table 2**  
**Heat Tape Selection Table for Proper**  
**Pipe Protection with Fiberglass and Outer Wrap**  
 (Tape Installed Straight Along Pipe) \*

Method of Wrapping	Nominal Copper Pipe Size									
	3/8"	1/2"	3/4"	1"	1-1/4"	1-1/2"	2"	3"	4"	6"
Tape Required per Foot of Pipe	1'	1'	1'	1'	1'	1'	1'	1'	1'	1'
Protection Down to (F)	-60	-41	-30	-19	-12	-6	0	+9	+14	+26

\* All values calculated at 0 MPH wind, metallic pipe. Fiberglass wrap should not be used with non-automatic models unless used in conjunction with properly installed thermostat.

**Table 3**  
**Heat Tape Selection Table for Proper**  
**Pipe Protection with Fiberglass and Outer Wrap**  
 (Tape Installed Spiralled Around Pipe 3 Turns per Foot) \*

Method of Wrapping	Nominal Copper Pipe Size									
	3/8"	1/2"	3/4"	1"	1-1/4"	1-1/2"	2"	3"	4"	6"
Tape Required per Foot of Pipe	NR	NR	1'6"	1'8"	1'10"	2'1"	2'4"	2'11"	3'11"	5' 0"
Protection Down to (F)	NR	NR	-60	-55	-51	-50	-45	-41	-37	-35

\* All values calculated at 0 MPH wind, metallic pipe. Fiberglass wrap should not be used with non-automatic models unless used in conjunction with properly installed thermostat.  
 NR = Not Recommended.

**Table 4**  
**Electrical Data for**  
**CGA 10 and 15 ton units**

Model Number	Basic Unit Characteristics				Compressor Motor			Outdoor Fan Motor		
	Unit Electrical Characteristics	Allowable Voltage Range	Minimum Circuit Ampacity	Maximum Fuse Size	Qty.	Amps		Qty.	HP	FLA
						RLA	LRA			
CGA120B1	208-230/60/1	187-254	71.0	90	2	28.9	150	1	1	6.0
CGA120B3	208-230/60/3	187-254	48.3	60	2	18.8	118	1	1	6.0
CGA120B4	460/60/3	414-506	25.2	35	2	10.0	71	1	1	2.7
CGA120BW	575/60/3	518-632	17.3	20	2	6.8	43	1	1	2.0
CGA180B3	208-230/60/3	187-254	72.6	90	2	29.5	156	2	.5	3.1
CGA180B4	460/60/3	414-506	33.6	40	2	13.5	79	2	.5	1.6
CGA180BW	575/60/3	518-632	26.7	35	2	10.8	57	2	.5	1.2

**Notes:**

1. Minimum circuit ampacity is 125% of the largest compressor RLA (see Table 4) plus 100% of the second compressor RLA plus the sum of the condenser fan FLAs per NEC 440-33.
2. Maximum fuse size is 225% of the largest compressor RLA plus 100% of the second compressor RLA plus the sum of the condenser fan FLAs, per NEC 440-22.

3. Recommended dual-element fuse size is 150% of the largest compressor RLA plus 100% of the second compressor RLA plus the sum of the condenser fan FLAs.
4. Rated load amps (RLA) rated in accordance with UL Standard 466.
5. Use copper conductors only.
6. Local codes may take precedence.

**Table 5  
Minimum Starting Ambient  
Temperatures for CGA Units**

	Standard Units		Low Ambient Units	
	with HGBP	No HGBP	with HGBP	NO HGBP
CGA120B	60	50	15	0
CGA180B	60	45	15	0

Notes:

1. Minimum starting ambients in degrees F, based on unit at minimum step of unloading and 5 mph wind across condenser.

**Table 6  
Control Settings and  
Time Delays for CGA Units**

Control Description	Electrical Designation	Contacts Open	Contacts Close (Reset)
High Pressure Cutout	HPC01, HPC02	400 ± 10 psig	250 ± 15 psig
Low Pressure Cutout	LPC01, LPC02		
Std. Units		38.5 ± 1 psig	44.5 ± 2 psig
*LLST Units		See Table 6A	See Table 6A
Low Temperature Cutout	LTC		
Std. Units		36 ± 1.5° F	Manual Reset
*LLST Units		See Table 6A	See Table 6A
Control Description	Electrical Designation	Contact Status	Time Delay Duration
Anti-Short Cycle Timer	ASCT1, ASCT2	Normally-open timed to close	3 Minutes
Delay Between Compressors	DBC	Normally-open timed to close	30 Seconds
Low Ambient Start Timer	LAST1, LAST2	Normally-Closed timed to open	4 minutes
Hot Gas Bypass Timer	HGBT	Normally-Closed timed to open	30 Minutes

\*LLST = Low Leaving Solution Temp Units.

**Table 6A  
Control Settings for  
Low Leaving Solution Temperature Units**

Minimum Design LST (deg F)	Ethylene-Glycol Concentration (%)	Solution Freeze Temp (F)	Low Temperature Cutout (deg F)		Low Pressure Cutout (psig)	
			Open	Close	Open	Close (Reset)
35	8	27	31	Manual Reset	33.8	38.5
30	13	22	27	Manual Reset	29.1	33.8
25	19	17	22	Manual Reset	24.9	29.1
20	24	11	16	Manual Reset	20.1	24.0
10	32	2	7	Manual Reset	13.9	17.2

Note: The settings are field adjusted to match the required leaving solution temperature.

## Electrical Wiring:

### General

**WARNING: TO PREVENT INJURY OR DEATH, DISCONNECT ELECTRICAL POWER SOURCE BEFORE COMPLETING WIRING CONNECTIONS TO UNIT.**

All wiring must comply with National Electrical Code (NEC) and state and local requirements. Outside the United States, the national and/or local electrical requirements of other countries shall apply. The installer must provide properly sized system interconnecting and power supply wiring with appropriate fused disconnect switches. Type and locations of disconnects must comply with all applicable codes.

**CAUTION: Use only copper conductors for terminal connections to avoid corrosion and overheating.**

Figures 2 and 3 show the locations of the unit electrical access openings. Table 4 provides minimum circuit ampacities, recommended fuse sizes, and motor electrical data.

### CGA Unit Power Supply

Refer to the unit wiring schematic pasted to the control panel cover. The installer must provide a power supply of proper voltage and a fused disconnect switch to the CGA unit.

Run properly sized power wiring through the electrical access opening on the front of the CGA unit, (see Figures 2 and 3), and connect it to the High Voltage Terminal Block (HTB) in the unit control panel. Install a fused disconnect switch as required by local codes. Provide proper equipment grounds for the ground connections in the unit control panel and at the fused disconnect switch.

**Important!** All 208-230 volt units are factory-wired for 230 volt applications. If the power supply voltage is less than 215 VAC, refer to the unit electrical schematic pasted to the inside of the control panel cover to convert the transformer to 208 volt.

### Heat Tape

#### Power Supply (For Unit Evaporator)

The evaporator is insulated from ambient air, and protected from freezing by thermostatically controlled heat tape(s). Whenever the thermostat senses  $40\text{ F} \pm 6\text{ F}$ , it closes, energizing the heat tape(s).

Provide an independent power source with a fused disconnect switch to the evaporator heater junction box shown in the unit schematic diagram. Power requirement for unit heat tape only is 115V max fuse size is 7 amps. Customer connections are illustrated in Figures 2 and 3. Electrical wiring between the evaporator heat tape and the junction box is factory installed.

### Heat Tape

#### Power Supply (For Field-Installed Piping)

Provide power supply wiring—along with a properly sized fused disconnect switch—for any electrical heat tape applied to the system water piping.

### Interconnecting System Wiring

**WARNING: TO PREVENT INJURY OR DEATH, DISCONNECT ELECTRICAL POWER SOURCE BEFORE COMPLETING WIRING CONNECTIONS TO UNIT.**

**CAUTION: Use copper conductors only to prevent galvanic corrosion and overheating at terminal connections.**

### Chilled Water Pump Motor (CWPM)

#### Power Supply

Refer to the unit wiring schematic pasted to the control panel cover. The installer must provide a power supply of proper voltage and a fused disconnect switch to the chilled water pump motor circuit.

Run properly sized power wiring to the chilled water pump motor and install a fused disconnect switch as required by local codes. Provide proper equipment grounds for the ground connections at the pump motor and at the fused disconnect switch.

Notice that the chilled water pump starter (CWPS) must have two normally—open auxiliary contacts; one of which must be wired in series with and upstream of the flow switch.

### Flow Switch Interlock

To avoid possible evaporator freeze-up resulting from restricted water flow, install a flow switch (or other flow sensing device) in the evaporator water line; see "Unit Water Piping". This sensing device must be adjusted to stop compressor operation if water flow to the evaporator drops below 50 percent of the system design full-flow rate.

The installing contractor must provide interconnecting wiring between the unit control panel, the auxiliary contacts of the chilled water pump starter (CWPS), and the flow-sensing device in the evaporator water line. Connect the switch between LTB1-8 and LTB1-9 in the unit control panel.

### Factory Supplied, Field Installed Accessories

The following is a list of factory supplied, field installed accessories that may be purchased with the CGA 10 and 15 ton units. For proper installation and wiring (if applicable) of each accessory, refer to the installer's guide that ships with each accessory.

1. Integrated Comfort System Interface\*
2. Head Pressure Control(s) (Low Ambient Controls)
3. Power Supply Monitor\*\*
4. Elapsed Time Meter/# of Starts Counter
5. Flow Switch
6. Unit Isolators
7. Coil Guard Kit
8. Pressure Gauges

\*ICS kit and TCM module are both required for Integrated Comfort System Interface. These two items must be ordered separately.

\*\* Not available on Single Phase Units

# Installation Checklist

---

Complete this checklist as the unit is installed to verify that all recommended procedures are accomplished before the unit is started. **This checklist does not replace the detailed instructions given in the "Installation" section of this manual!** Read the entire section carefully to become familiar with installation procedures before installing the unit.

## Receiving

- Verify that unit nameplate data corresponds with ordering information.
- Inspect unit for shipping damages and material shortages; report any damages or shortages found to the carrier.

## Unit Location and Mounting

- Inspect unit installation location for adequate ventilation.
- Provide drainage facilities for evaporator water.
- Remove and discard any shipping materials (e.g., cartons, crates, etc.)
- Inspect to determine that service access clearances are adequate.
- Install optional unit neoprene-in-shear or spring-flex isolators.
- Secure unit to mounting surface.
- Level the unit.

## Evaporator Piping

- Flush and clean all chilled water piping.

**CAUTION: If using an acidic commercial flushing solution, construct a temporary bypass around the unit to prevent damage to internal components of the evaporator.**

**CAUTION: To avoid possible equipment damage, do not use untreated—or improperly treated—system water.**

- Make evaporator water connections.
- Vent chilled water system at high points in system piping.
- Install pressure gauges, thermometers and shutoff valves on water inlet and outlet piping.
- Install water strainer in evaporator supply line.
- Install balancing valve and flow switch on water outlet piping.
- Apply heat tape and insulation as necessary to protect all exposed field installed piping from freeze-up.

## Electrical Wiring

**WARNING: TO PREVENT INJURY OR DEATH, DISCONNECT ELECTRICAL POWER SOURCE BEFORE COMPLETING WIRING CONNECTIONS TO UNIT.**

**CAUTION: Use only copper conductors to prevent galvanic corrosion and overheating at terminal connections.**

- Connect unit power supply wiring (with fused disconnect) to appropriate terminals on terminal block (HTB) in power section of unit control panel.
- 208-230 Volt Units Only. If supply power is 208 V, modify transformer wiring as described on unit wiring diagrams.
- Connect chilled water pump power supply wiring (with fused disconnect) to the proper terminals of the chilled water pump.
- Properly ground the CGA unit, the chilled water pump motor, all disconnects, and other devices which require grounds.
- Install wiring between field-supplied, fused disconnect switch and unit evaporator heat tape junction box.
- Connect power supply wiring, along with a fused disconnect switch, to any auxiliary heat tape installed on system water piping.
- Install wiring to connect chilled water pump switch (CWPSW) to chilled water pump starter (CWPS).
- Connect auxiliary contacts of chilled water pump starter (CWPS) to flow switch and unit control panel.
- Install wiring to connect flow switch to unit control panel.

## Field-Installed Accessories

- Install and wire any accessories per the appropriate installer's guide (see "Electrical Wiring: Factory Supplied, Field Installed Accessories").

# Pre-Start Procedures

---

## Pre-Start Checklist

Once the unit is installed, complete each step in the checklist that follows, check off each step as it is completed. When all are accomplished, the unit is ready for operation.

**WARNING: MORE THAN ONE DISCONNECT SWITCH MAY BE REQUIRED TO DE-ENERGIZE UNIT FOR SERVICING. REFER TO UNIT SCHEMATIC AND OPEN ALL ELECTRICAL DISCONNECTS TO PREVENT INJURY OR DEATH DUE TO ELECTRICAL SHOCK.**

Inspect all wiring connections; electrical connections should be clean and tight.

**WARNING: USE EXTREME CARE WHEN ELECTRICALLY TROUBLESHOOTING COMPRESSORS. IF ELECTRICAL POWER IS APPLIED TO A DAMAGED FUSITE TERMINAL, A FIRE OR EXPLOSION COULD OCCUR, RESULTING IN INJURY OR DEATH.**

**CAUTION: Check tightness of all connections in the compressor power circuit (disconnects, terminal block, contactors, compressor junction box terminals, etc.) to prevent overheating at connections and under voltage conditions at the compressor motor.**

Check power supply voltage to the unit at the main power fused disconnect switch; the voltage reading obtained must be within the voltage utilization range shown in Table 4. Also, voltage imbalance must not exceed 2 percent. (Refer to "Unit Voltage and Amperage Checks")

Check the condenser fan assemblies; the fan blades should rotate freely in the fan orifice, and be securely attached to the fan shaft.

Remove control circuit Fuse (FU) from the main unit control panel; then energize the compressor crankcase heaters by closing the unit's fused disconnect switch. The crankcase heaters should operate at least 8 hours before the compressors are allowed to start.

**Note:** To prevent compressor operation during this 8-hour interval, control circuit Fuse (FU) must be removed from the unit control panel.

**CAUTION: Compressor crankcase heaters must be energized at least 8 hours before unit start-up to prevent compressor mechanical damage.**

Fill the chilled water (evaporator) circuit, leaving the system air vents open. Close vents after filling.

**CAUTION: Do not use untreated or improperly treated water, or equipment damage may result.**

Close the chilled water circuit fused disconnect switch, and start the chilled water pump motor (CWPM). With water circulating through the chilled water system, inspect all piping connections for leaks and make any necessary repairs.

Adjust the water flow rate through the chilled water circuit, and check the water pressure drop through the evaporator. Refer to "Water System".

Open the CGA unit disconnect switch; then reinstall control circuit Fuse (FU) in the unit control panel (i.e., provided the compressor crankcase heaters have been energized at least 8 hours), and reclose the disconnect switch. Adjust the flow switch (installed on the evaporator outlet piping) to provide proper operation.

**Note:** With the water pump operating, throttle the water flow to approximately 50 percent of the full flow rate. Following the manufacturer's instructions, adjust the flow switch contacts to open at this point. Use an ohmmeter to verify opening and closure of the switch contacts.

Stop the chilled water pump.

Open all fused disconnect switches.

## Unit Voltage and Amperage Checks

**WARNING: USE EXTREME CARE WHEN CHECKING VOLTAGE AND AMPERAGE AT LIVE TERMINALS TO AVOID SERIOUS INJURY OR DEATH DUE TO ELECTRICAL SHOCK.**

Electrical power to the unit must meet stringent requirements for the unit to operate properly. Total voltage supply and voltage imbalance between phases should be within the following tolerances.

### Voltage Supply 3-Phase Units Only

Measure each leg of supply voltage at all line voltage disconnect switches. Readings must fall within the voltage utilization range shown on the unit nameplate. If voltage on any leg does not fall within tolerance, notify the power company to correct this situation before operating the unit. Inadequate voltage to the unit will cause control components to malfunction and shorten the life of electrical components and compressor motors.

### Voltage Imbalance

Excessive voltage imbalance between phases in a three-phase system will cause motors to overheat and eventually fail. Maximum allowable imbalance is 2 percent. Voltage imbalance is defined as follows:

$$\% \text{ Voltage Imbalance} = \frac{100 \times |V_A - V_D|}{V_A}$$

where  $V_A = \frac{V_1 + V_2 + V_3}{3}$  (Avg. Voltage)

$V_1, V_2, V_3$  = Line Voltages

$V_D$  = Line voltage that deviates farthest from  $V_A$

#### Example:

If the three voltages measured at the line voltage fused disconnect are 221 volts, 230 volts and 227 volts, the average ( $V_A$ ) would be:

$$\frac{221 + 230 + 227}{3} = 226 \text{ volts}$$

The percentage of imbalance is then:

$$\frac{100 \times |226 - 221|}{226} = 2.2 \%$$

The 2.2 percent imbalance that exists in the example above exceeds maximum allowable imbalance by 0.2 percent. This much imbalance between phases can equal as much as 20 percent current imbalance with a resulting increase in winding temperature that will decrease compressor motor life.

**Table 7  
CGA Evaporator Data**

Unit	Water* Volume	Minimum Flow Rate	Maximum Flow Rate
	gal.	gpm	gpm
CGA120B	1.4	12	36
CGA180B	1.5	18	54

\* Includes water tubing provided by the factory.

### Water System: Water Flow Rates

Establish a balanced water flow through the evaporator. Flow rates should fall between the minimum and maximum values indicated in Table 7. Evaporator water flow rates below the minimum acceptable values will result in a stratified flow; this reduces heat transfer and causes either loss of expansion valve control or repeated nuisance low pressure cutouts. Conversely, excessively high flow rates may cause erosion of components in the evaporator.

### Pressure Drop Measurement

Measure the water pressure drop through the evaporator at the pressure gauge(s) on the system water piping. Pressure drop readings at the gauges should approximate those indicated by the pressure drop chart in Figure 6.

**Note:** The pressure drop curves shown in Figure 6 are calculated at the unit water inlet and outlets. Be sure to account for any piping or fittings that may create an additional pressure drop between the unit and the pressure gauge locations.

**Figure 6  
CGA 10 and 15 ton  
Evaporator Water  
Pressure Drop (English)**

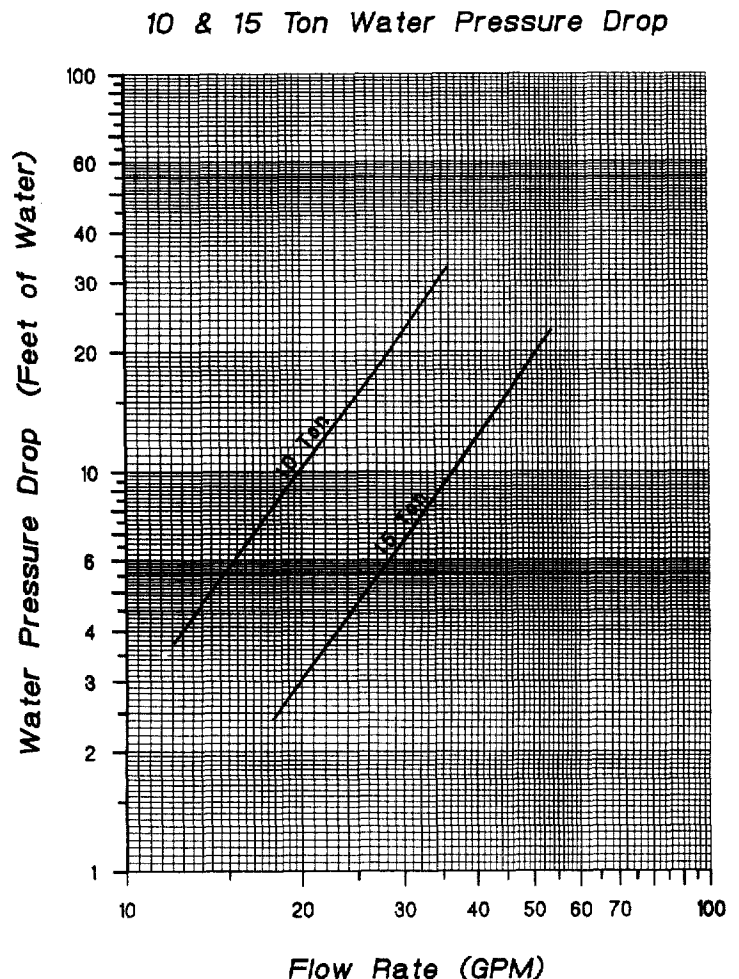

**Table 8**  
**Normal Operating Pressures (Approximate)**

Ambient (F)	CGA120		CGA180	
	Suction Press (psig)	Disch Press (psig)	Suction Press (psig)	Disch Press (psig)
45	58	128	56	139
60	59	163	58	174
75	60	204	59	214
85	61	234	60	244
95	62	266	61	276
105	63	301	62	310
115	64	339	63	347

- NOTES:
1. Based on steady state conditions with 54° F entering water temp (EWT) and 44° F leaving water temperature (LWT).
  2. An increase of 5° F in LWT while keeping the 10° F temperature drop will result in an increase of approximately 6 psi in suction pressure and an increase of approximately 10 psi in discharge pressure when compared to the 54° EWT, 44° LWT given in Table 8.
  3. Pressures at low ambients will not match this table if a head pressure control is installed and operating.

**Ethylene Glycol Adjustment Factor**

The addition of ethylene glycol to the chilled water system reduces unit capacity. To determine pressure drop of a glycol solution, obtain the pressure drop adjustment factor from the chart in Figure 7 and multiply times the pressure drop of water without glycol, i.e.;

$$\text{Glycol } \Delta P = \text{H}_2\text{O } \Delta P \times \text{Adj. Factor}$$

**Figure 7**  
**Performance Adjustments and Solution Freezing Points (Ethylene Glycol in Evaporator)**

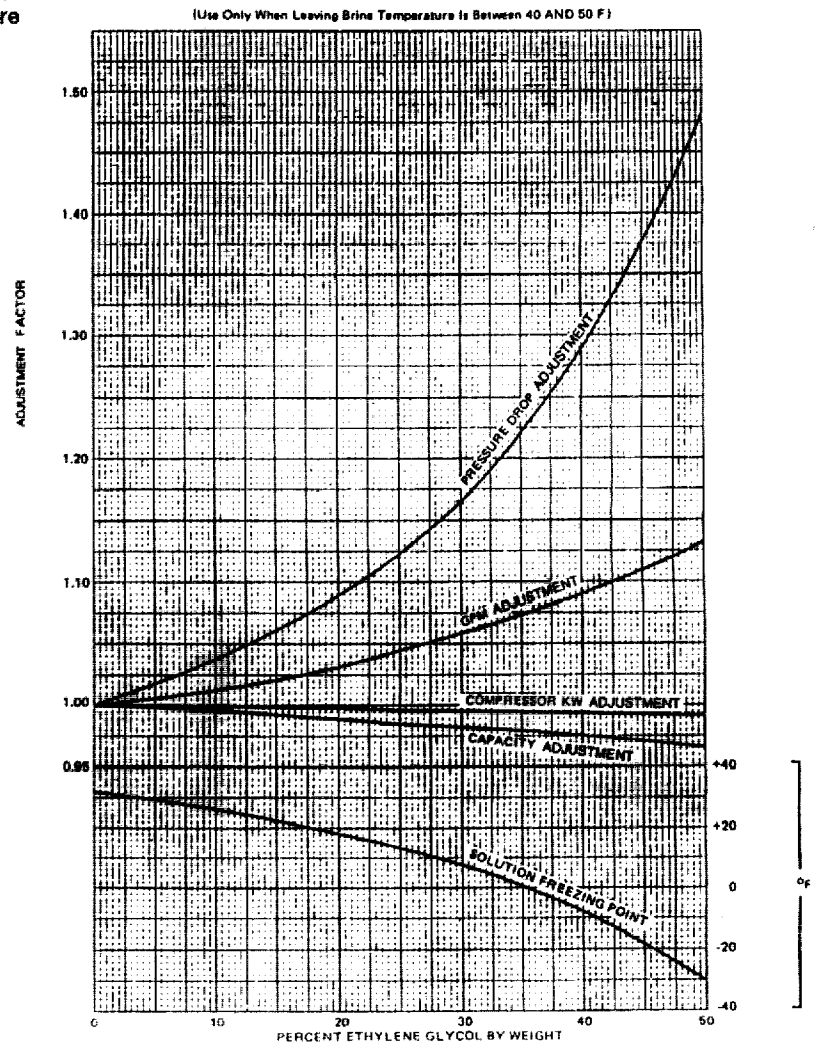



# Operation

---

## Start-Up Procedure

To properly start the unit, execute each step of the checklist that follows in the sequence indicated; check off each step as it is completed. Do not start the unit until the "Pre-Start Procedures" are complete. (Refer to Figure 9 for the unit operating controls locations.)

Open the unit disconnect switch; then remove control circuit Fuse (FU) from the unit control panel. (This will prevent the compressors from energizing when the disconnect switch is closed.)

**WARNING: MORE THAN ONE DISCONNECT SWITCH MAY BE REQUIRED TO DE-ENERGIZE UNIT FOR SERVICING. REFER TO UNIT SCHEMATIC AND OPEN ALL ELECTRICAL DISCONNECTS TO PREVENT INJURY OR DEATH DUE TO ELECTRICAL SHOCK.**

Close the fused disconnect switch for the evaporator chilled water pump. Start the pump.

Close the fused disconnect switch for the CGA unit.

**Note:** The unit's compressor crankcase heaters will energize when the disconnect switch is closed; these crankcase heaters must operate at least 8 hours before the compressors are allowed to start.

**CAUTION: Compressor crankcase heaters must be energized at least 8 hours before unit start-up to prevent compressor mechanical damage.**

After the compressor crankcase heaters have operated a minimum of 8 hours, open the unit disconnect switch, reinstall control circuit Fuse (FU) in the unit control panel, and reclose the disconnect switch.

Energize the evaporator heaters by closing the fused disconnect switch provided by the installer. (The factory-installed evaporator heat tape should be energized whenever there is water in the unit evaporator.)

Reset any control that requires a manual reset.

If the unit is a low leaving solution temperature model, adjust the low pressure cutout setting and the low temperature cutout setting according to Table 6A. Disconnect power before adjusting.

Set the water temperature thermostat (WTT) as described on page 22.

## Checking Operating Conditions

Once the unit has operated for at least 30 minutes and the system has stabilized, complete the following checklist to ensure proper unit operation.

Re-check evaporator water flow and pressure drop. These readings should be stable at proper levels. Refer to "Water System". If pressure differential drops off, clean all evaporator water supply strainers.

Measure unit suction and discharge pressures by installing pressure gauges on the discharge and suction line access ports. Refer to Table 8 for approximate normal operating pressures.

**Note:** Many application variables exist which can affect operating pressures; these include ambient dry bulb temperature, as well as the installation of such options as head pressure controls or hot gas bypass. Since these variables can give misleading results, do not use operating pressures as the sole check of system operation.

Check compressor amp draw.

Check electrical power supply.

Check the liquid line sight glasses/moisture indicators for the presence of moisture.

**Note:** Bubbles in the liquid line may indicate either a low refrigerant charge, or excessive pressure drop in the liquid line. Such a restriction can often be identified by a noticeable difference in line temperature on either side of the restricted area. (Frost often forms on the outside of the liquid line at the point of restriction, as well.) Bubbles are not necessarily a symptom of improper system operation.

**CAUTION: A clear sight glass does not necessarily mean that the system is sufficiently charged; be sure to consider system superheat, subcooling, and unit operating pressures and ambient temperatures.**

Proper unit refrigerant charge—per circuit—is indicated on the unit nameplate and also under "Refrigerant Charge Information" on page 18 of this manual.

Measure system superheat.

Normal system superheat is 12 to 15 deg F for each circuit at ARI conditions (54° entering water, 44° leaving water, and 95° ambient temperature). If the superheat measured for either circuit does not fall within this range, alter the setting of the superheat adjustment on the thermal expansion valve to obtain the desired reading. Allow 15 to 30 minutes between adjustments for the expansion valve to stabilize at each new setting.

Measure system subcooling.

Normal subcooling for each circuit is 12 to 22 deg F at ARI conditions (54° entering water, 44° leaving water, and 95° ambient temperature). If subcooling for either circuit is not in this range, check superheat for the circuit and adjust, if required. If superheat is normal but subcooling is not, contact a qualified service technician.

If operating pressure, sight glass, superheat and subcooling readings indicate refrigerant shortage, find and repair leaks and, gas-charge refrigerant into each circuit. Refrigerant shortage is indicated if operating pressures are low and subcooling is also low.

## Refrigerant Charge Information

The CGA120B units have 9 lbs 8 oz. of refrigerant per circuit, and the CGA180B units have 12 lbs. 7 oz. of refrigerant per circuit.

**CAUTION: If suction and discharge pressures are low, but subcooling is normal, no refrigerant shortage exists. Adding refrigerant will result in overcharging.**

Add refrigerant vapor with the unit running by charging through the access port on the suction line until operating pressures are normal.

**CAUTION: To prevent compressor damage, do not allow liquid refrigerant to enter the suction line. Liquid charge at the liquid line only.**

[ ] If operating pressures indicate an overcharge, slowly (to minimize oil loss) recover refrigerant at the liquid line service valve.

### Important Note:

Do **Not** release refrigerant to the atmosphere! Refer to general service bulletin MSCU-SB-1 (latest edition).

**WARNING: TO PREVENT INJURY DUE TO FROSTBITE, AVOID SKIN CONTACT WITH REFRIGERANT.**

[ ] If the unit is equipped with hot gas bypass, check regulating and solenoid valves for proper operation.

[ ] Be sure that all remote sensing bulbs are properly installed in bulb wells with heat transfer compound. Remote bulb capillary tubes must be secured (i.e., protected from vibration and abrasion) and undamaged.

[ ] Inspect the unit. Remove any debris, tools and hardware. Secure all exterior panels, including the control and compressor access panels. Replace and tighten all retaining screws.

## Temporary Unit Shutdown and Restart

To shut down the unit for a short time:

1. Open the unit disconnect switch; then remove control circuit Fuse (FU) from the main unit control panel. Once control circuit Fuse (FU) is removed, reclose the unit disconnect switch. This will ensure that the compressor crankcase heaters remain energized.

**WARNING: TO PREVENT INJURY OR DEATH DUE TO ELECTRICAL SHOCK, DO NOT USE THIS PROCEDURE TO SHUT DOWN THE UNIT FOR SERVICE. SERVICE PROCEDURES MUST BE PERFORMED WITH UNIT DISCONNECT(S) OPEN.**

2. Stop operation of the chilled water pump.

To restart the unit after a temporary shutdown:

1. Restart the chilled water pump.  
2. Open the unit disconnect switch; then reinstall control circuit Fuse (FU) in the main unit control panel. Once Fuse (FU) is installed, close the unit disconnect switch.

**WARNING: TO PREVENT INJURY OR DEATH DUE TO ELECTRICAL SHOCK, OPEN UNIT DISCONNECT SWITCH BEFORE INSTALLING CONTROL CIRCUIT FUSE (FU) IN CONTROL PANEL.**

The unit will now operate normally provided that: (1) the water temperature thermostat (WTT) is calling for cooling, and (2) all system operating interlocks and safety circuits are satisfied.

## Extended Unit Shutdown/Winterization

If the system is taken out of operation for long periods of time for any reason (e.g., seasonal shutdown), use this procedure to prepare the system for shutdown:

1. Check the refrigerant piping for leaks, fixing any that exist.  
2. Service the chilled water pump and any air handling equipment according to the manufacturer's recommendations.  
3. Open both electrical disconnect switches for the unit and chilled water pump; lock both disconnects in the open position.

**CAUTION: Lock both unit and chilled water pump disconnects in open position to prevent compressor or pump damage due to accidental start-up while system is in "shutdown" condition.**

Winterization: Close all evaporator water supply valves and drain the evaporator by removing the drain plug and opening the vent on the entering water line just outside the unit. Re-install the drain plug. Since the evaporator does not drain completely, add one quart of ethylene glycol antifreeze to the remaining water through the vent or evaporator drain hole, to keep the water from freezing. Or refer to Table 7 and fill the evaporator with antifreeze. Protect system to 10 F below the expected ambient temperature and energize the evaporator heat tape(s) by closing the heat tape fused disconnect switch provided by the installer.

**CAUTION: To prevent freeze damage to evaporator internal components, protect with adequate strength antifreeze, and be certain to energize evaporator heat tapes.**

**NOTE:** If system has been drained for shutdown do not energize heat tape(s).

## System Restart after Extended Shutdown

Use this procedure to prepare the system for restart after an extended shutdown:

1. Remove winterization antifreeze as it can reduce system capacity.
2. Verify that both the unit and the chilled water pump disconnect switches are open; then remove control circuit Fuse (FU) from the unit control panel.
3. Close the unit disconnect switch to energize the compressor crankcase heaters.

**Note:** The unit's compressor crankcase heaters will energize when the disconnect switch is closed; these crankcase heaters must operate at least 8 hours before the compressors are allowed to start.

**CAUTION: Compressor crankcase heaters must be energized at least 8 hours before unit start-up to prevent compressor mechanical damage.**

4. Fill the chilled water (i.e., evaporator) circuit; evaporator storage capacities are indicated in Table 7 (see "Water System"). Be sure to vent the system while filling it, and close the vent when system is full.

**CAUTION: To avoid possible equipment damage, do not use untreated—or improperly treated—system water.**

5. Close the chilled water circuit disconnect switch, and start the chilled water pump motor. With water circulating through the chilled water system, inspect all piping connections for leaks and make any necessary repairs.
6. Adjust the water flow rate through the chilled water circuit, and check the water pressure drop through the evaporator. Refer to "Water System".
7. Adjust the flow switch (installed on the evaporator outlet piping) to provide proper operation.

**Note:** With the water pump operating, throttle the water flow to approximately 50 percent of the full flow rate. Following the manufacturer's instructions, adjust the flow switch contacts to open at this point. Use an ohmmeter to check for contact opening and closure.

8. Stop the chilled water pump.
9. Open all fused disconnect switches; then reinstall control circuit Fuse (FU) (removed in Step 1) in the main unit control panel.

The unit is now ready for normal operation; refer to "Start-Up Procedure".

## Low Ambient Operation:

### Field Installed

#### Head Pressure Control Accessory

Standard units will operate in outdoor ambient temperatures down to (50 deg F - CGA120, 45 deg F - CGA180) w/o HGBP. This accessory will enable units to operate down to 0 deg F w/o HGBP. (See Table 5).

Head pressure control for CGA units is regulated by means of a field installed head pressure accessory which varies condenser fan speed in relation to discharge pressure.

When discharge pressure is 270 psig or higher, the condenser fan runs at full speed. At pressures between 270 psig and 180 psig, the fan speed is adjusted (increased or decreased) in direct relation to the pressure, with minimum fan speed (10% of rated motor RPM) occurring when the pressure reaches 180 psig. At pressures below 180 psig, the fan will not run.

When discharge pressure rises to 180 psig, the fan will start and run at the reduced speed. Fan speed will continue to increase as the pressure increases until full speed is reached at 270 psig.

## Freeze Protection

If the unit will remain operational at subfreezing ambient temperatures, follow the recommendations outlined below to ensure adequate protection for the chilled water system.

1. Energize the chilled water piping heat tape at the fused disconnect switch supplied by the installing contractor. Verify that all exposed piping is adequately protected.
2. "Freeze-proof" the chilled water system by adding a nonfreezing, low-temperature heat transfer fluid to the chilled water. The solution used must be strong enough to provide sufficient protection to prevent ice formation at 10 F below the lowest expected ambient temperature.

Follow the manufacturer's recommendations for installation and testing procedures for any freeze-proofing fluid used. Refer to Table 7 for evaporator liquid capacities.

**Note:** Use of an ethylene-glycol type fluid will reduce system capacity. This factor must be considered during system design. (See Figure 7).

## Electrical Control System

The controls used on CGA 10 and 15-ton units are classified either as "safety" controls or "operational" controls. Brief descriptions of the specific safety and operating controls used in the CGA control scheme are provided in the following paragraphs.

Refer to the following control descriptions and to Tables 6 and 6A for control settings, and to Figure 9 for control locations.

### Unit Safety Controls:

#### Low Pressure Cutout (LPCO1, LPCO2)

These units are protected by low pressure cutouts that open and stop compressor operation if the operating pressure drops below  $38.5 \pm 1$  psig. The cutout automatically resets when the pressure reaches  $44.5 \pm 2$  psig. The LPCO is a Single Pole Double Throw (SPDT) device and if it opens at low ambient start-up, it will energize Outdoor Fan (ODF) relay, stopping the outdoor fan(s) while the compressor remains energized through the Low Ambient Start Timer (LAST).

#### (Low Leaving Solution Temperature Units)

The LPCO open and reset values are to be field adjusted based on the ethylene glycol concentration per the values shown in Table 6A.

### High Pressure Cutout (HPC01, HPC02)

These units have high pressure cutouts that open and stop compressor operation if the discharge pressure reaches  $400 \pm 10$  psig. The cutout automatically resets when pressure drops to  $250 \pm 15$  psig.

### Reset Relays (RR1, RR2)

If the unit is shut down by the low pressure cutout (or high pressure cutout), the reset relay locks out the compressor contactor (CC1, CC2). This prevents the system from recycling until the condition that caused the low (or high) pressure cutout to trip is determined and corrected.

**CAUTION: To prevent unit damage, do not reset the control circuit until the cause of the safety lockout is identified and corrected.**

To reset RR1 and RR2, open and reclose the unit disconnect switch.

### Low Temperature Cutout (LTC)

The LTC is designed to protect the evaporator from freeze damage in the event of a water temperature thermostat (WTT) malfunction or restricted water flow. The LTC's remote sensing bulb is mounted at the outlet end of the evaporator, where it monitors leaving water temperature. If—during normal unit operation—the leaving chilled water temperature falls to the trip point, the LTC will open to interrupt compressor operation. (Manual reset is required).

#### (Low Leaving Solution Temperature Units)

The LTC open value is to be field adjusted based on the ethylene glycol concentration per the values shown in Table 6A.

### Motor Overloads

These units have internal compressor and condenser fan motor overloads. These overloads protect the motors from overcurrent and overheating conditions and automatically reset as soon as they cool sufficiently.

### Unit Operational Controls:

#### Water Temperature Thermostat (WTT)

System operation for 10 and 15-ton CGA units is governed by a two-stage water temperature thermostat (WTT). The remote sensing bulb of this device is factory-installed in a bulb well located on the evaporator water inlet; here, it monitors the temperature of the water returning to the evaporator. It has a control range of 5° F per stage, a differential of 5.0 deg F between stages and a set point range of -30 to + 100 deg F.

For an explanation on determining the WTT's setpoint and a description of the WTT in operation refer the page 22.

### Low Ambient Start Timer (LAST1, LAST2)

When LAST1 or LAST2 energizes, the low pressure control is bypassed for 4 minutes, this allows time for suction pressure to build sufficiently for the low pressure cutout contacts to close.

**Note:** A low ambient start timer checkout procedure is given on page 28 of this manual.

### Hot Gas Bypass Timer, Solenoid (HGBT, HGBS)

The hot gas bypass option is factory installed only, and is used in a chilled water system to keep the 1st stage compressor on line and maintain suction pressure to a set point during short no-load or light-load conditions. When Water Temperature Thermostat (WTT) 1st stage opens, 24V power is supplied to the Compressor Contactor (CC1) through Hot Gas Bypass Timer (HGBT) pins 1 and 4. Power is also applied from WTT-B to HGBT coil (fixed 30 minute time delay pick-up) and to the Hot Gas Bypass Solenoid (HGBS) through HGBT pins 8 and 5. If 1st stage cooling remains satisfied for 30 minutes, HGBT coil will energize and open HGBT pins 1 and 4 shutting down the compressor. If there is a call for cooling during HGBP mode, the unit will return to cooling mode.

The adjustable hot gas bypass valve is factory set to begin opening at 70 psig.

**Note:** Hot gas bypass is available only on the lead compressor circuit.

### Anti-Short Cycle Timers (ASCT1, ASCT2)

An anti-short cycle timer is provided in each compressor control circuit to protect the compressors from starting too frequently. This can occur as a result of poor thermostat control associated with light loads and water loops that are too short. It can also occur because of sudden power outages of short duration. Whenever the contacts of the water temperature thermostat (WTT) open—or when there is a momentary power outage—the anti-short cycle timer will lock out compressor operation for 3 minutes.

### Delay Between Compressors (DBC)

The delay between compressors prevents both compressors from starting at the same time by delaying compressor #2 for 30 seconds.

---

## Unit Control System

### Sequence of Operation

Refer to the unit wiring schematic pasted to the inside of the control panel cover when reviewing the control sequence described below. Refer to this legend for an explanation of the acronyms used in this sequence.

CWFIR \_\_\_\_\_ Chilled Water Flow Interlock Relay  
LPCO \_\_\_\_\_ Low Pressure Cutout  
HPCO \_\_\_\_\_ High Pressure Cutout  
ASCT \_\_\_\_\_ Anti-short Cycle Timer  
CC \_\_\_\_\_ Compressor Contactor  
LTC \_\_\_\_\_ Low Temperature Cutout  
DBC \_\_\_\_\_ Delay Between Compressors  
WTT \_\_\_\_\_ Water Temperature Thermostat  
RR \_\_\_\_\_ Reset Relay  
CWPS \_\_\_\_\_ Chilled Water Pump Starter

### 10 Ton Operation

With unit fused disconnect switch closed, power is supplied to the crankcase heaters, and the 24 V control circuit.

Starting the chilled water pump closes the CWPS Aux contacts and completes the flow switch.

When the entering water temperature (EWT) rises 5° F above the WTT's setpoint, its first stage switch closes, allowing power to pass through CWPS Aux contacts, the flow switch, the LTC, the ASCT1, the RR1 contacts, the LPCO1, and the HPCO1 to energize the CC1 coil. This starts compressor #1 and the outdoor fan.

### Single Phase Units Only

The single phase compressor requires a start capacitor and a run capacitor to operate. When the CC1 coil energizes and its normally-open contacts close, both the compressor start capacitor (CS1) and the compressor run capacitor (CR1) energize. CR1 remains energized as long as CC1 is energized, but CS1 is dropped out of the circuit when compressor start relay (CSR1) energizes and opens its normally-closed contacts.

If the EWT rises 10°F above the WTT's setpoint, its 2nd stage switch closes, allowing power to pass through the DBC switch, the ASCT2, the RR2 contacts, the LPCO2, and the HPCO2 to energize the CC2 coil which starts compressor #2.

### 15 Ton Operation

With unit fused disconnect switch closed, power is supplied to the crankcase heaters, and the 24 V control circuit.

Starting the chilled water pump closes the CWPS Aux contacts and completes the flow switch, allowing power to pass through the LTC to energize the CWFIR.

When the entering water temperature (EWT) rises 5° above the WTT's setpoint, its first stage switch closes, allowing power to pass through the CWFIR contacts, the ASCT1, the RR1 contacts, the LPCO1, and the HPCO1 to energize the CC1 coil. This starts compressor #1 and outdoor fan #1.

If the EWT rises 10° F above the WTT's setpoint, its 2nd stage switch closes, allowing power to pass through the CWFIR contacts, the DBC switch, the ASCT2, the RR2 contacts, the LPCO2, and the HPCO2 to energize the CC2 coil. This starts compressor #2 and outdoor fan #2.

## Determining the setpoint for the Water Temperature Thermostat (WTT)

To determine the WTT setpoint, divide the system design delta T by two, and add that number to the desired average Leaving Water Temperature (LWT avg.).

$$\text{Equation: WTT setpoint} = (\text{Design } \Delta T \div 2) + \text{LWT avg.}$$

After determining the WTT setpoint, check the minimum LWT.

$$\text{LWT min} = \text{WTT setpoint} - \text{Design } \Delta T.$$

**CAUTION:** To prevent the possibility of ice forming in the system loop, make sure that the minimum leaving water temperature (LWT min) is not lower than 40 deg F. If the (LWT min) is lower than 40 deg F, add the appropriate amount of ethylene glycol and adjust the safety control settings as shown in Table 6A.

Example:

Design  $\Delta T = 10 \text{ deg F}$   
Desired Average LWT = 45 deg F

$$\begin{aligned} \text{WTT Setpoint} &= (10 \div 2) + 45 \\ &= 50 \text{ deg F} \end{aligned}$$

$$\begin{aligned} \text{LWT min} &= 50 - 10 \\ &= 40 \text{ deg F} \end{aligned}$$

In this example, the WTT setpoint is 50 deg F, and the LWT min is 40 deg F. Since the LWT min is not below 40 deg F, there is no need to add ethylene glycol.

## Water Temperature Thermostat Operation

At start up, if the entering water temperature (EWT) is less than 5 deg F above the WTT setpoint, the unit will not run. When the EWT rises to 5 deg F above the WTT setpoint, its first stage switch closes, energizing compressor #1.

If the EWT continues to rise and reaches 10 deg F above the WTT setpoint, its second stage switch closes, energizing compressor #2.

When the cooling demand is met and the EWT drops to 5 deg F above the WTT setpoint, its second stage switch opens, dropping out compressor #2.

If the EWT continues to fall and reaches the WTT setpoint, its first stage switch opens, dropping out compressor #1.

A graphic representation of the above explanation is shown in figure 8.

**Figure 8**  
**WTT Switching Action**

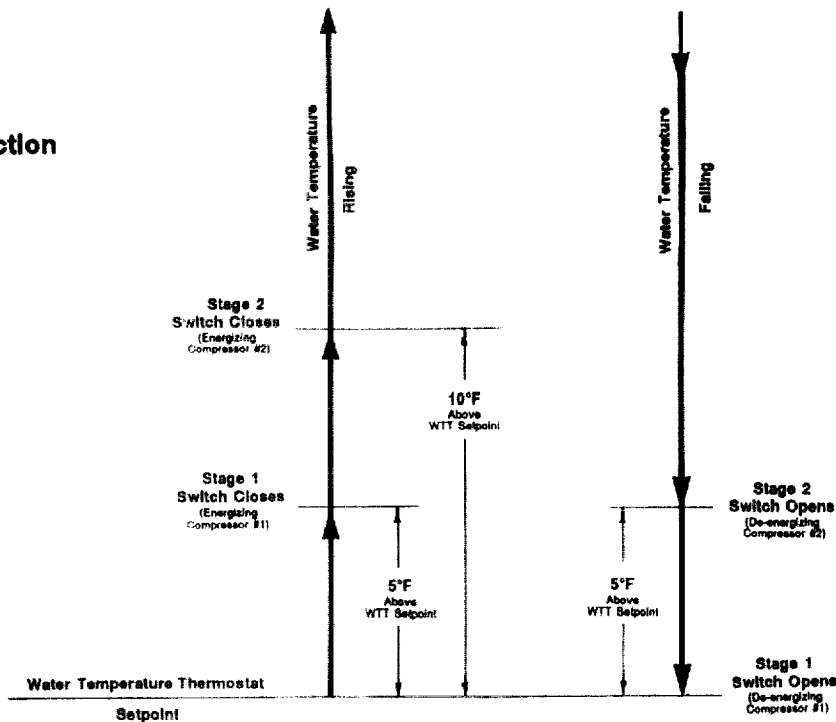

**Figure 9  
Unit Control Panels**

**CGA120 Control Panel**

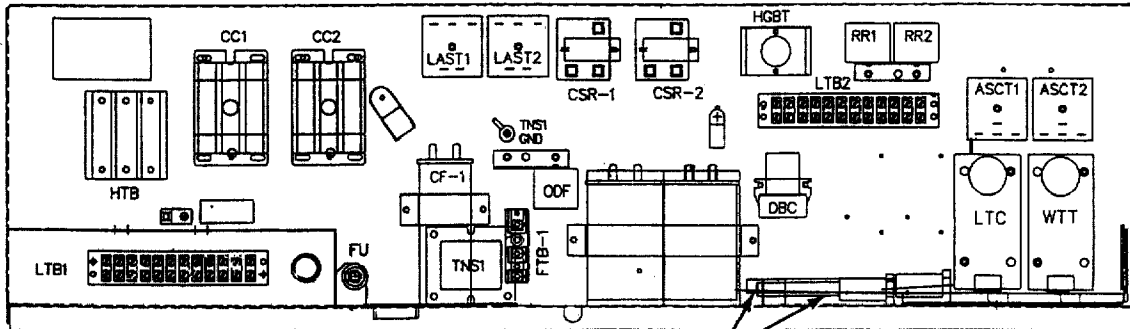

DRG. 21D661765

LTC and WTT bulbs are installed in the entering and leaving water lines.

- |              |                                    |              |                              |
|--------------|------------------------------------|--------------|------------------------------|
| ASCT1, ASCT2 | Anti-Short Cycle Timers            | HTB          | High Voltage Terminal Block  |
| CC1, CC2     | Compressor Contactors              | LAST1, LAST2 | Low Ambient Start Timers     |
| CF1, CF2     | Outdoor Fan Capacitors             | LTB1, LTB2   | Low Voltage Terminal Blocks  |
| CWFIR        | Chilled Water Flow Interlock Relay | LTC          | Low Temperature Cutout       |
| DBC          | Delay Between Compressors          | ODF1, ODF2   | Outdoor Fan Relays           |
| FTB1, FTB2   | Fan Terminal Blocks                | RR1, RR2     | Reset Relays                 |
| FU           | Control Circuit Fuse               | TNS1         | Control Power Transformer    |
| HGBT         | Hot Gas Bypass Timer               | WTT          | Water Temperature Thermostat |
| LPCO1, LPCO2 | Low Pressure Cutouts               |              |                              |

**CGA180 Control Panel**

LTC and WTT bulbs are installed in the entering and leaving water lines.

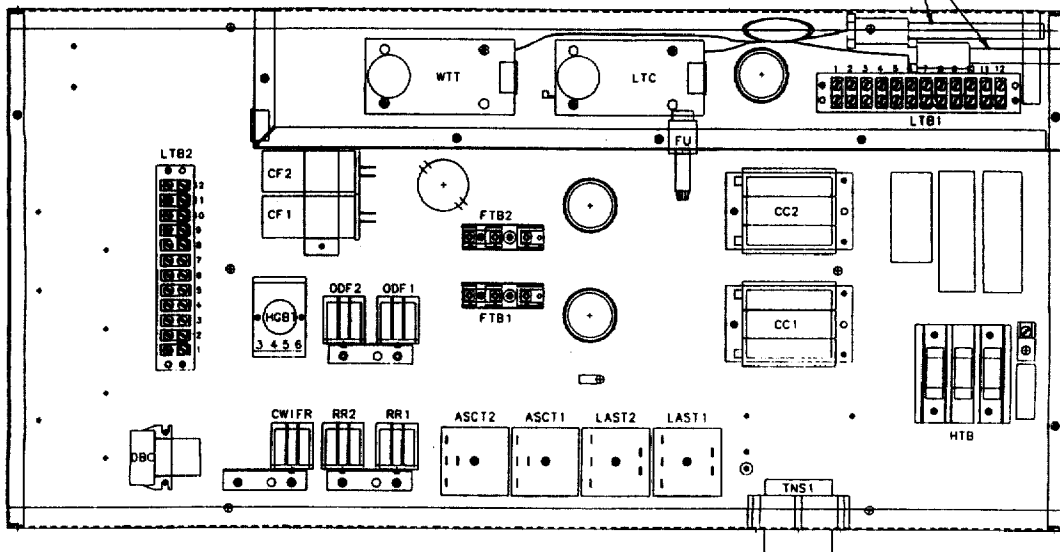

DrG. 21D728704

**Figure 10**  
**Unit Refrigeration Schematic**  
**for CGA120B Units**

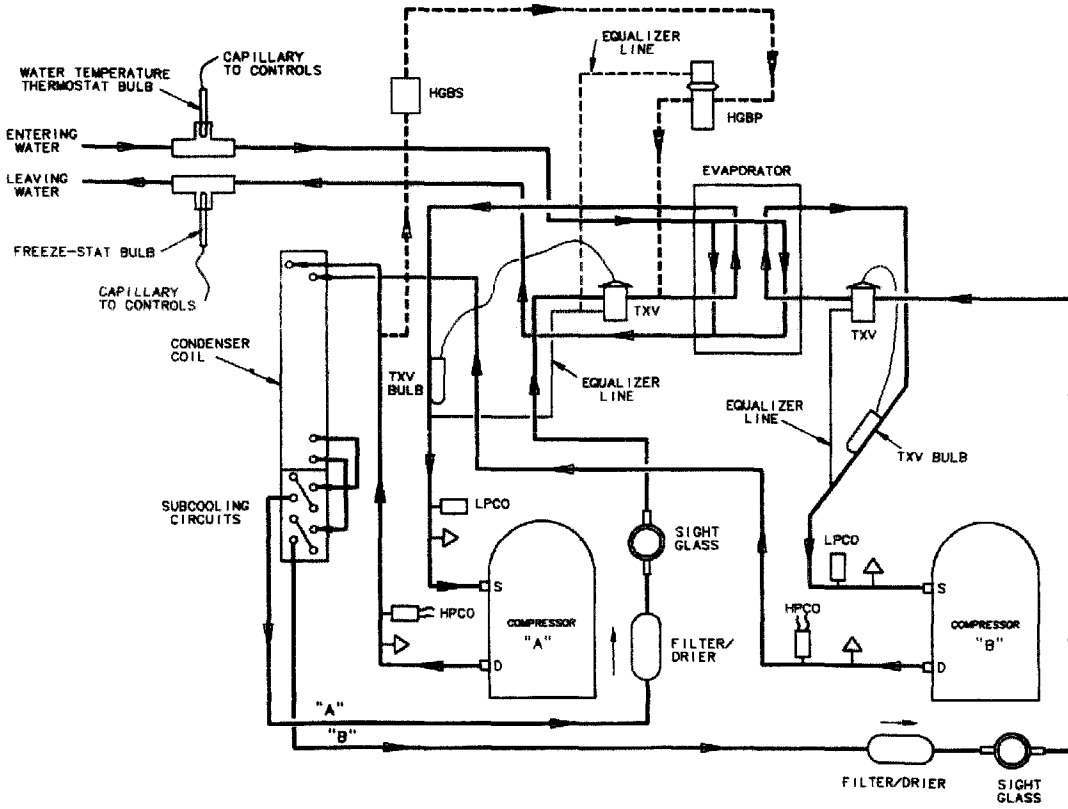

NOTES: 1. CIRCUITS THROUGH THE CONDENSER COIL ARE NOT SHOWN.

**SYMBOL DEFINITION**

- PRESSURE GAGE CONNECTION
- LPCO LOW PRESSURE CONTROL CONNECTION
- HPCO HIGH PRESSURE CUT OUT SWITCH
- TXV THERMAL EXPANSION VALVE
- HGBS HOT GAS BYPASS SOLENOID (ALTERNATE CONSTRUCTION-FACTORY INSTALLED)
- HGBP HOT GAS BYPASS VALVE (ALTERNATE CONSTRUCTION-FACTORY INSTALLED)

Org. 21C661998

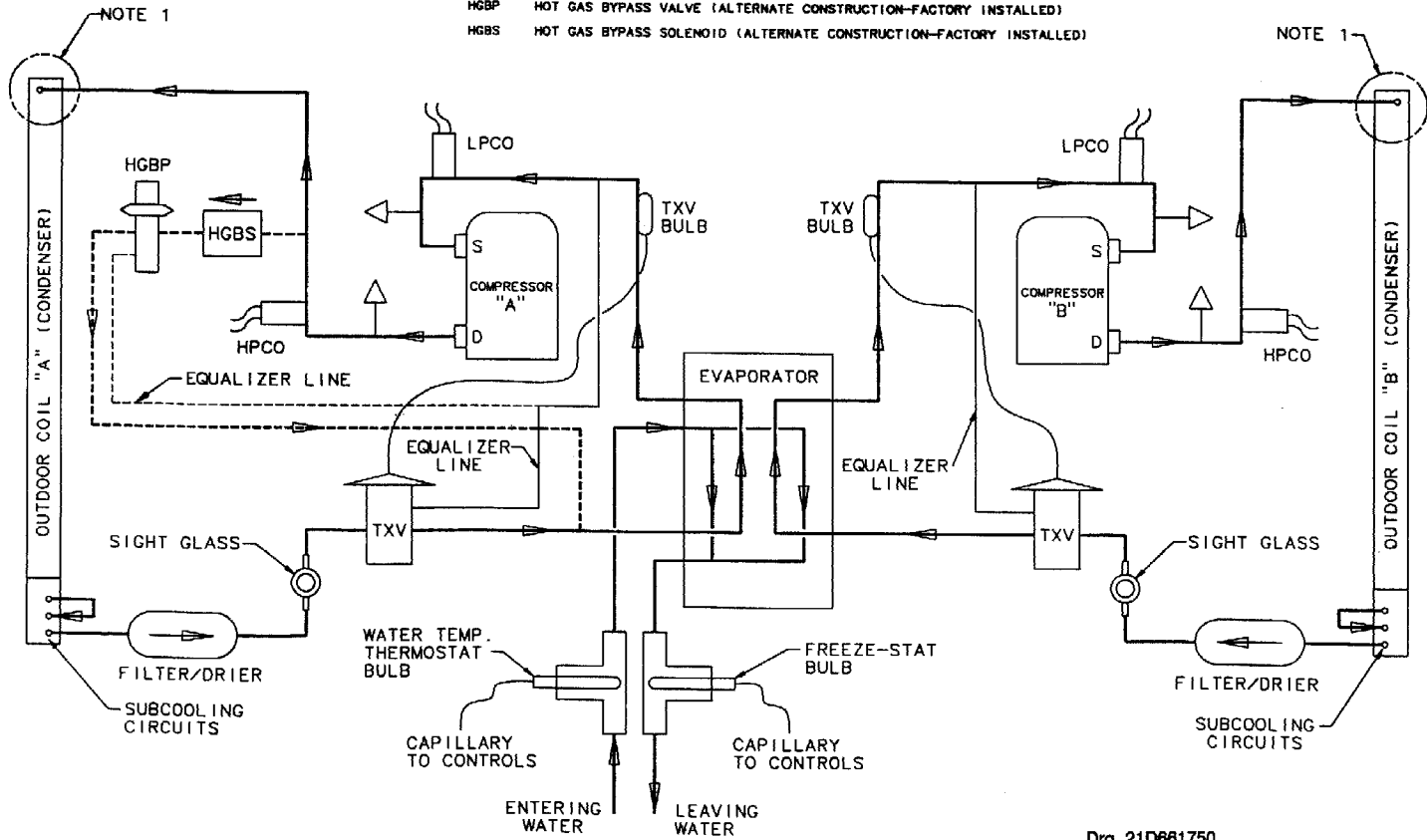

**Figure 11**  
**Unit Refrigeration Schematic**  
**for CGA180B Units**

NOTE 1: CIRCUITS THROUGH THE CONDENSER COILS ARE NOT SHOWN.

**SYMBOL DEFINITION**

- PRESSURE GAGE CONNECTIONS
- LPCO LOW PRESSURE CONTROL CONNECTION
- HPCO HIGH PRESSURE CUT OUT SWITCH
- TXV THERMAL EXPANSION VALVE
- HGBP HOT GAS BYPASS VALVE (ALTERNATE CONSTRUCTION—FACTORY INSTALLED)
- HGBS HOT GAS BYPASS SOLENOID (ALTERNATE CONSTRUCTION—FACTORY INSTALLED)



Drq. 21D681750

# Maintenance

---

## Periodic Maintenance

Perform all of the indicated maintenance procedures at the intervals scheduled. This will prolong the life of the unit and reduce the possibility of costly equipment failure.

**Note:** Use an "Operator's Log" (such as the one at the back of this manual) to record a weekly operating conditions history for the unit. This operating log can be a valuable diagnostic tool for service personnel; by noticing trends in operating conditions, the operator can often foresee and prevent problem situations before they become serious.

If the unit does not perform properly during any of these maintenance inspections, consult the "Trouble Analysis" section of this manual for possible causes and recommended repairs.

## Weekly Maintenance

Once the unit has been operating for about 30 minutes and the system has stabilized, check operating conditions and complete the checkout procedure described below:

Check suction and discharge pressures. (Refer to "Checking Operating Conditions".)

Check the liquid line sight glasses/moisture indicators. (Refer to "Checking Operating Conditions".)

If operating pressures and sight glass/moisture indicator conditions indicate a refrigerant shortage, measure system superheat and system subcooling. (Refer to "Checking Operating Conditions".)

If operating conditions indicate an overcharge, slowly (to minimize oil loss) recover refrigerant at the liquid line service valve.

### Important Note:

Do **Not** release refrigerant to the atmosphere! Refer to general service bulletin MSCU-SB-1 (latest edition).

## WARNING: TO PREVENT INJURY DUE TO FROSTBITE, AVOID SKIN CONTACT WITH REFRIGERANT.

Inspect the entire system for unusual conditions and inspect coils for dirt and debris. If coils are dirty, clean them. (Refer to "Coil Cleaning").

**Note:** Use an operating log (such as the one at the end of this manual) to record a weekly operating conditions history for the unit. A complete operating log is a valuable diagnostic tool for service personnel.

## Monthly Maintenance

Perform all weekly maintenance procedures.

Measure and record system superheat.

Measure and record system subcooling.

Open the unit disconnect switch; then manually rotate the outdoor fans to ensure proper orifice clearance.

## WARNING: MORE THAN ONE DISCONNECT MAY BE REQUIRED TO DE-ENERGIZE UNIT FOR SERVICING. REFER TO UNIT SCHEMATIC AND OPEN ALL ELECTRICAL DISCONNECTS TO PREVENT INJURY OR DEATH DUE TO ELECTRICAL SHOCK.

Inspect the fan mounting bolts for tightness.

Check fan set screws for tightness.

## Annual Maintenance

Perform all weekly and monthly maintenance procedures.

Have a qualified service technician check the setting and function of each control and inspect the condition of all contactors and replace as necessary.

If the chiller is not piped to drain facilities, make sure the drain is clear to carry away system water.

Drain water from evaporator and associated piping systems. Inspect all piping components for leakage, damage, etc. Clean out any in-line water strainers.

Clean and repaint any corroded surfaces.

Clean condenser coils. (Refer to "Coil Cleaning").

Inspect the expansion valve sensing bulbs for cleanliness; clean if required. These sensing bulbs must make good contact with the suction lines, and must be properly insulated.

Determine whether or not lubrication of the outdoor fan motor bearings is needed; lubricate bearings with a light-weight oil (e.g., SAE-20 non-detergent or equivalent), if necessary.

**Note:** CGA outdoor fan motor assemblies are permanently lubricated and usually do not require additional oiling unless the unit is installed in a "dirty" environment. Under such conditions, lubricate the fan motor bearings after every 10,000 hours of operation. Do not over-lubricate!

Clean condenser fans.

## Maintenance Procedures

This section describes specific maintenance procedure(s) which must be performed as a part of the normal maintenance program for this unit. Be certain that electrical power to the unit is disconnected before performing these procedures.

## WARNING: MORE THAN ONE DISCONNECT SWITCH MAY BE REQUIRED TO DE-ENERGIZE UNIT FOR SERVICING. REFER TO UNIT SCHEMATIC AND OPEN ALL ELECTRICAL DISCONNECTS TO PREVENT INJURY OR DEATH DUE TO ELECTRICAL SHOCK.

---

## Coil Cleaning

Clean the condenser refrigerant coil at least once each year (or more frequently if the unit is located in a "dirty" environment) to help maintain proper unit operating efficiency. Specific instructions for cleaning refrigerant coils are outlined below. Follow these instructions as closely as possible to avoid potential damage to the coils.

To clean the refrigerant coil, a soft brush and sprayer (i.e., either a garden pump-up type, or a high-pressure sprayer) must be used. In addition, a high-quality detergent is required; suggested brands include "SPREX A.C.", "OAKITE 161", "OAKITE 166", and "CQILOX".

**Note:** If the detergent is strongly alkaline (i.e., has a pH value greater than 8.5) after mixing, an inhibitor must be added.

### Cleaning Procedure:

1. Disconnect power to the unit.

**WARNING: MORE THAN ONE DISCONNECT SWITCH MAY BE REQUIRED TO DE-ENERGIZE UNIT FOR SERVICING. REFER TO UNIT SCHEMATIC AND OPEN AND LOCK ALL ELECTRICAL DISCONNECTS TO PREVENT INJURY OR DEATH DUE TO ELECTRICAL SHOCK.**

2. Remove enough panels and components from the unit to gain access to the condenser coils.
3. Protect all electrical devices such as motors and controls from dust and water.
4. Straighten coil fins with a fin rake, if necessary.
5. Use a soft brush to remove loose dirt and debris from both sides of the coil.
6. Mix the detergent with water according to the manufacturer's instructions. To improve the cleansing ability of the solution, heat it to a maximum of 150 F.

**WARNING: SPRAYING COIL WITH A SOLUTION HOTTER THAN 150 F MAY CAUSE COIL TO BURST, RESULTING IN POSSIBLE INJURY AND EQUIPMENT DAMAGE.**

7. Place the cleaning solution in the sprayer. Be sure to follow these guidelines if a high-pressure sprayer is used: (1) minimum nozzle spray angle is 15 degrees; (2) spray solution at 90 degrees to the coil face; (3) keep sprayer nozzle at least six inches from the coil; and, (4) sprayer pressure must not exceed 600 psi.
8. Spray the leaving air side of the coil first; then spray the entering air side of the coil. Allow the detergent-and-water solution to stand on the coil for 5 minutes.
9. Rinse both sides of the coil with cool, clean water.
10. Inspect the condenser coil. If it still appears to be dirty, repeat Steps 7 and 8.
11. Remove protective covers installed in step 3.
12. Reinstall all unit components and panels; then restore electrical power to the unit.

## Cleaning the Evaporator

The chilled water system is a closed loop. It should not accumulate a large amount of scale or sludge. If the chiller is fouled, first try to dislodge foreign material by backflushing the system several times. If this does not work, take a water sample from the evaporator and analyze it. Determine treatment based on the findings.

**CAUTION: Do not use an acidic type cleaning agent that will damage the internal evaporator components.**

### Water Treatment

The use of untreated or improperly treated water in these units may result in the formation of scale, erosion, corrosion, algae or slime. It is recommended that the services of a qualified water treatment specialist be engaged to determine what treatment, if any, is required. The Trane Company assumes no responsibility for equipment failure that results from the use of untreated or improperly treated water.

# Trouble Analysis

---

## Low Ambient Start Timer (LAST) Checkout Procedure

To determine whether or not a low ambient start timer is defective, follow these steps.

1. Remove power from the CGA unit by opening the supply power fused disconnect switch.
2. Disable both low pressure cutouts (LPC01 and LPC02) by disconnecting the wires from their number 1 terminals. Tape the disconnected wires to prevent shorting.
3. Restore power to the system, energize compressor number one and check how long it runs before cutting out.
4. Remove power from the system and disable compressor number one. Tape any wires removed to prevent shorting.
5. Restore power to the system, energize compressor number two and check how long it runs before cutting out.
6. Remove power from the system and re-connect the wires removed from the low pressure cutouts in step two. Re-connect the wires that disabled compressor number one.
7. Restore power to the unit.

**Conclusion:** Compare the compressor run times verified in steps 3 and 5 with the rated duration of the low ambient start timers. (The rated duration times are usually stamped on the timers or given in the unit literature). If the compressor run times don't match the duration times of the low ambient start timers, the timers are defective and must be replaced.

## Preliminary Troubleshooting Inspection

If operational difficulties are encountered, be sure to perform these preliminary checks before referring to the troubleshooting charts:

- [ ] Check the water temperature thermostat (WTT) to ensure that it is set correctly, receiving control power, and "making/breaking" at the proper intervals.
- [ ] Verify that the unit is receiving electrical supply power, and that the fuses in the fused disconnect switch(es) and main control panel are intact.
- [ ] Check the evaporator for proper water supply. Check the flow switch for proper operation, and take pressure drop readings across the evaporator.

After completing the preliminary checks described above, be sure to inspect the unit for other obvious causes of trouble such as an excessively dirty condenser coil, leaking water connections, broken or disconnected wires, etc. If everything appears to be in order—but the unit still fails to operate properly—refer to the appropriate troubleshooting chart and contact a qualified service technician.

## Troubleshooting Charts

The troubleshooting charts which follow are provided to serve as an aid for identifying the cause of any system malfunctions that may occur. Within each chart are three columns: (1) the Symptom column describes the behavior the unit is exhibiting; (2) the Probable Cause column identifies the most likely sources of the malfunction; and, (3) the Recommended Action column describes the suggested action for correcting the problem.

**Note:** The troubleshooting charts which follow are provided solely as a guide for determining the cause of mechanical failure or malfunction. When mechanical problems do occur, The Trane Company recommends that qualified service personnel be contacted to help ensure proper diagnosis and repair of the unit.

**WARNING: TO AVOID INJURY OR DEATH DUE TO ELECTRICAL SHOCK OR CONTACT WITH MOVING PARTS, NEVER OPEN ACCESS PANEL(S) TO INSPECT OR SERVICE UNIT WITHOUT FIRST OPENING UNIT DISCONNECT SWITCH(ES).**

## Symptom

### A. Compressor neither starts nor hums.

Probable Cause	Recommended Action
1. No power to unit.	Check for the following: a. Disconnect switch open. b. Fuse(s) blown.
2. No call for cooling.	Check for the following: a. Defective thermostat. b. Broken or improper control wiring. c. Blown control power fuse.
3. Anti-short cycle timer has not timed out.	Wait at least 3 minutes for the anti-short cycle timer to time out.
4. Unit locked out by reset relay.	Check for the following: a. Excessive discharge pressure; see "Discharge Pressure Too High." b. Defective high pressure control. c. Low Charge; Low pressure switch open. d. Defective reset relay contact.
5. Compressor contactor will not close.	Check for the following: a. Defective compressor contactor. b. Improper wiring. c. Reset relay open. d. Low pressure control open. e. Cooling relay not energized. Defective relay; check thermostat circuit. See Probable Cause #2 above.
6. Compressor winding stat open.	See "Compressor Motor Winding Stat Open". a. Check compressor amp draw.

## Symptom

### B. Compressor hums, but will not start.

Probable Cause	Recommended Action
1. Low voltage at compressor.	Check for the following: a. Single blown fuse. b. Low line voltage. c. Defective compressor contactor. d. Loose wiring connections.
2. Defective compressor.	Check for the following: a. Open motor winding. b. Excessive amp draw on all phases.
3. Insufficient starting Voltage (Single-Phase Units Only)	Check for the following: a. Defective start capacity b. Defective Start Relay

## Symptom

### C. 2nd stage compressor fails to start.

Probable Cause	Recommended Action
1. Time delay contacts fail to close.	Replace time delay relay.
2. No call for cooling.	Check for the following: a. Defective thermostat. b. Broken or improper control wiring.
3. Unit locked out by reset relay.	See Symptom A, Probable Cause #4.
4. Compressor contactor will not close.	See Symptom A, Probable Cause #5.

## Symptom

### D. Compressor short cycles.

Probable Cause	Recommended Action
----------------	--------------------

(Continued on Next Page)

1. Intermittent contact in control circuit.

Check for the following:

- a. Defective relay contacts.
- b. Loose wiring connections.

## Symptom

### E. Compressor runs continuously.

#### Probable Cause

#### Recommended Action

1. Unit undersized for load (cannot maintain water temperature).

Check for cause of excessive load.

2. Thermostat setpoint too low.

Readjust thermostat.

3. Defective thermostat or control wiring.

Replace thermostat. Replace or repair control wiring.

4. Welded contacts on compressor contactor.

Repair or replace contactor.

5. Leaky valves in compressor (indicated by abnormally low discharge and high suction pressures).

Replace compressor.

6. Shortage of refrigerant (indicated by reduced capacity, high superheat, low subcooling, and low suction pressure).

Find and repair refrigerant leak. Recharge system.

## Symptom

### F. Compressor motor winding stat open.

#### Probable Cause

#### Recommended Action

1. Excessive load on evaporator (indicated by high supply water temperature).

Check for the following:

- a. Excessive water flow.
- b. High return water temperature.

2. Lack of motor cooling (indicated by excessive superheat).

Check for the following:

- a. Improper expansion valve setting.
- b. Faulty expansion valve.
- c. Restriction in liquid line.

3. Improper voltage at compressor.

Check for the following:

- a. Low or imbalanced line voltage.
- b. Loose power wiring.
- c. Defective compressor contactor.

4. Internal parts of compressor damaged.

Replace compressor.

## Symptom

### G. Compressor is noisy.

#### Probable Cause

#### Recommended Action

1. Internal parts of compressor damaged or broken (compressor knocks).

Replace compressor.

2. Liquid floodback (indicated by abnormally cold suction line and low superheat).

Check and adjust superheat.

3. Liquid refrigerant in compressor at start-up (indicated by abnormally cold compressor shell).

Check crankcase heater.

Check for refrigerant overcharge

## Symptom

### H. System short of capacity.

#### Probable Cause

#### Recommended Action

1. Low refrigerant charge (indicated by high superheat and low subcooling).

Add refrigerant.

2. Clogged filter drier (indicated by temperature change in refrigerant line thru drier).

Replace filter drier or filter drier core.

3. Incorrect expansion valve setting.

Readjust expansion valve.

4. Expansion valve stuck or obstructed (i.e., high superheat and high water temperature).

Repair or replace expansion valve.

5. Low evaporator water flow.

Check strainers. Adjust water flow.

6. Noncondensibles in system.

Evacuate and recharge system.

7. Leaky valves in compressor (i.e., operation at abnormally high suction and low discharge pressures).

Replace compressor.

## Symptom

### I. Suction pressure too low.

#### Probable Cause

1. Shortage of refrigerant (i.e., high superheat, low subcooling).
2. Thermostat set too low (i.e., low discharge pressure, low leaving water temperature).
3. Low water flow.
4. Clogged filter drier.
5. Expansion valve power assembly has lost charge.
6. Obstructed expansion valve (i.e., high superheat).

#### Recommended Action

- Find and repair leak; recharge system.
- Readjust thermostat.
- Check for clogged strainers and incorrect balancing valve settings.
- Check for frost on filter drier. Replace if needed.
- Repair or replace expansion valve power head assembly.
- Clean or replace valve.

## Symptom

### J. Suction pressure too high.

#### Probable Cause

1. Excessive cooling load (i.e., high supply water temperatures).
2. Expansion valve over-feeding (i.e., superheat too low, liquid flooding to compressor).
3. Suction valves broken (i.e., noisy compressor).

#### Recommended Action

- See Symptom E.
- Adjust superheat setting; verify that remote bulb is properly attached to suction line.
- Replace compressor.

## Symptom

### K. Discharge pressure too low.

#### Probable Cause

1. Shortage of refrigerant (i.e., low subcooling, high superheat, bubbles in sight glass).
2. Broken or leaky compressor discharge valves.
3. Defective low pressure switch.
4. Unit running below minimum operating ambient.

#### Recommended Action

- Find and repair leak; recharge system.
- Replace compressor.
- Replace defective control.
- Provide adequate head pressure controls, or an ambient lockout switch.

## Symptom

### L. Discharge pressure too High.

#### Probable Cause

1. Too little or too warm condenser air; airflow restricted.
2. Air or noncondensable gas in system (i.e., exceptionally hot condenser).
3. Refrigerant overcharge (i.e., high subcooling, low superheat, high suction pressure).
4. Excessive system load.
5. Defective condenser fan or fan pressure control (i.e., 1 fan off, high condenser pressure).

#### Recommended Action

- Clean coil; check fans and motors for proper function.
- Evacuate and recharge system.
- Recover excess refrigerant.
- Reduce load.
- Repair or replace switch.







**TRANE™**

# Wiring

# CGA-W-2A

Library	Service Literature
Product Section	Refrigeration
Product	Recip. Liquid Chillers - A/C Cold Generators
Model	CGA
Literature Type	Unit Wiring
Sequence	2A
Date	March 1993
File No.	SV-RF-CG-CGA-W-2A-3/93
Supersedes	CGA-W-2-9/92

## 10 and 15 ton Air-Cooled Cold Generators®

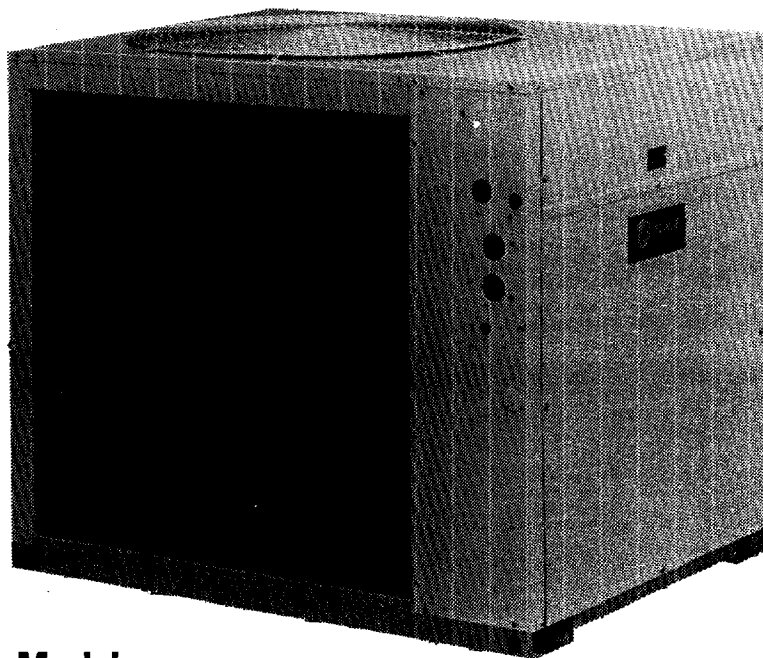

### Models

CGA 120 B \_ \_ \_ B \_

CGA 180 B \_ \_ \_ B \_

(Model # Digit 11 is "B")

Since the Trane Company has a policy of continuous product improvement, it reserves the right to change specifications and design without notice. The installation and servicing of the equipment referred to in this booklet should be done by qualified, experienced technicians.

# CGA 120B and 180B Unit Wiring Manual

---

## Table of Contents

- 02 Literature Change History
- 03 Model Number Description
  
- 04 CGA120B1 (208-230V/60/1) Schematic
- 06 CGA120B1 (208-230V/60/1) Connection
  
- 08 CGA120B3 (208-230V/60/3) Schematic
- 10 CGA120B3 (208-230V/60/3) Connection
  
- 12 CGA120B4 (460V/60/3) Schematic
- CGA120BW (575V/60/3) Schematic
  
- 14 CGA120B4 (460V/60/3) Connection
- CGA120BW (575V/60/3) Connection
  
- 16 CGA180B3 (208-230V/60/3) Schematic
- 18 CGA180B3 (208-230V/60/3) Connection
  
- 20 CGA180B4 (460V/60/3) Schematic
- CGA180BW (575V/60/3) Schematic
  
- 22 CGA180B4 (460V/60/3) Connection
- CGA180BW (575V/60/3) Connection

---

## Literature Change History

CGA-W-2 (September 1992)  
Original issue of manual; provides typical field and control panel connection diagrams and electrical schematics for 10 and 15 ton CGA units of "B" design. (See digit 11 of the unit model number.)

CGA-W-2A (March 1993)  
Revised Manual to include TCM changes.

## Warnings and Cautions

Notice that Warnings and Cautions appear at appropriate intervals throughout this manual.

Warnings are provided to alert installing contractors and operating or service personnel to potential hazards that could result in personal injury or death, while Cautions are intended to alert personnel to conditions, that could result in equipment damage.

Your personal safety and the proper operation of this system depend upon the strict observance of these precautions.

# Model Number Description

---

All standard Trane products are identified by a multiple-character model number that precisely identifies a particular type of unit. An explanation of the alphanumeric identification codes used for CGA units is provided on this page. Its use will enable the owner/operator, installing contractors, and service engineers to define the operation, components and options for any specific unit.

<u>C</u>	<u>G</u>	<u>A</u>	<u>1</u>	<u>2</u>	<u>0</u>	<u>B</u>	<u>3</u>	<u>0</u>	<u>0</u>	<u>B</u>	<u>A</u>
1	2	3	4	5	6	7	8	9	10	11	12

## Digits 1,2,3

### Unit Model

CGA = Cold Generator

## Digits 4,5,6

### Nominal Capacity

120 = 10 Tons

180 = 15 Tons

## Digit 7

### Form or Configuration

(Number of Refrigerant Circuits/  
Number of Compressors)

B = 2 Ref. Ckts/ 2 Compr.

## Digit 8

### Voltage

1 = 208-230V/60Hz/1 \*

3 = 208-230V/60Hz/3

4 = 460V/60Hz/3

W = 575V/60Hz/3

D = 380-415V/50Hz/3

\* = Not Available on CGA180 Units

## Digit 9

### Factory Installed Options

O = No Options

H = Hot Gas Bypass

C = Chromate Coil

K = Hot Gas Bypass  
and Chromate Coil

## Digit 10

### Expansion Valve

O = Standard Expansion Valve

V = Low Leaving Water Temp  
Expansion Valve

## Digit 11

### Major Design Change

B

## Digit 12

### Service Digit/Minor Design Change

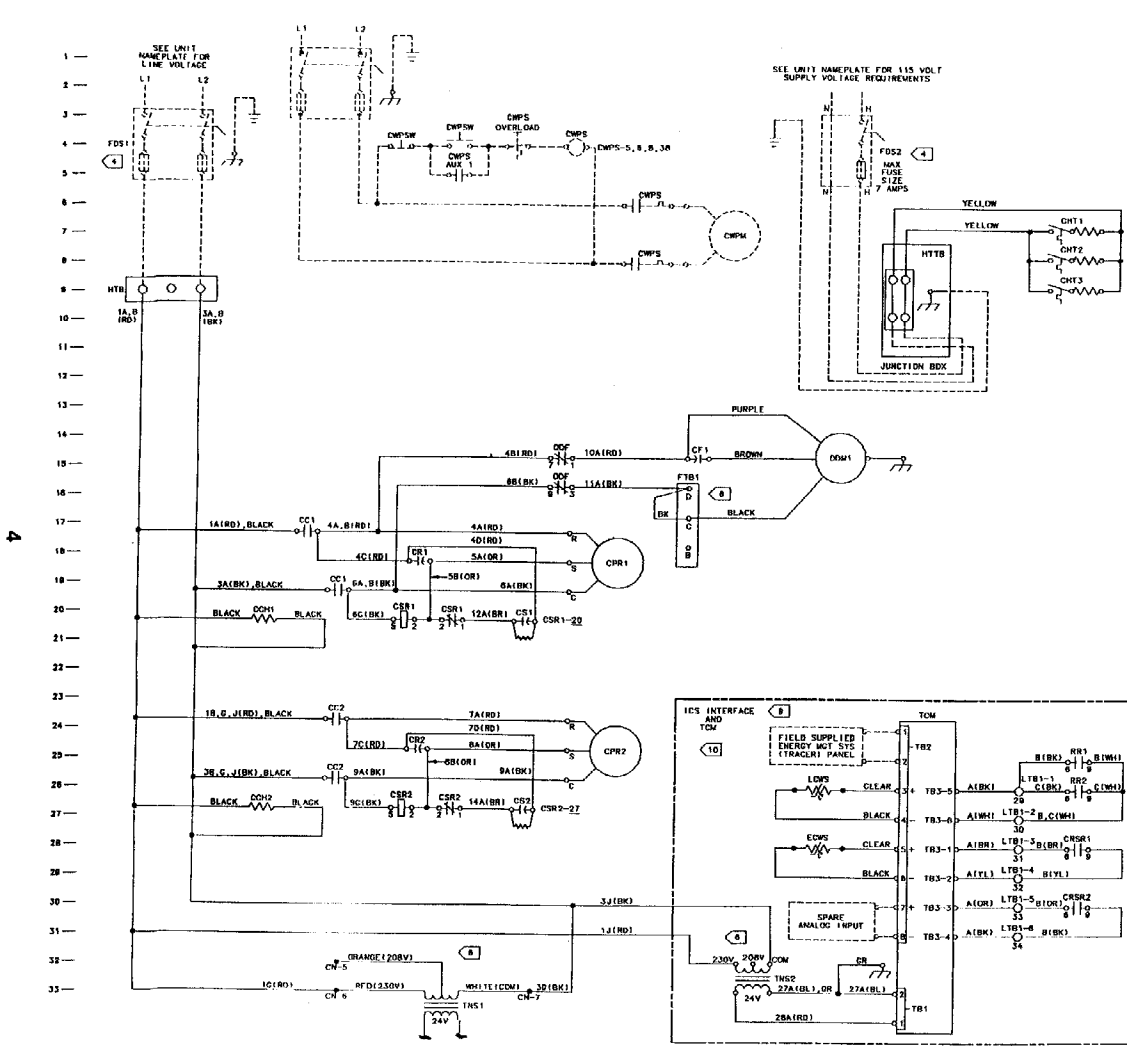

DEVICE DESIGNATION	DESCRIPTION	LINE NUMBER
ASC1, ASC2	ANTI-SHORT CYCLE TIMER	40, 50
CC1, CC2	COMPRESSOR CONTACTOR	41, 51
CCM1, CCM2	CRANKCASE HEATER	20, 27
CF	OUTDOOR FAN CAPACITOR	19
CHT1, CHT2, CHT3	CHILLER HEAT TAP	7, 8, 9
CN	CONNECTOR OR WIRF NUT	
CPR1, CPR2	COMPRESSOR	18, 24
CR1, CR2	COMPRESSOR RUN CAPACITOR	18, 25
CRM1, CRM2	COMPRESSOR RUN METER	44, 54
CRSR1, CRSR2	COMPRESSOR RUN STATUS RELAY	42, 52
CS1, CS2	COMPRESSOR START CAPACITOR	20, 27
CSE1, CSE2	COMPRESSOR START COUNTER	45, 55
CSR1, CSR2	COMPRESSOR START RELAY	20, 27
CWP	CHILLER WATER PUMP MOTOR	7
CWPS	CHILLER WATER PUMP STARTER	4
CWPSW	CHILLER WATER PUMP SWITCH	4
DBC	DELAY BETWEEN COMPRESSORS	39
ECWS	ENTERING CHILLED WATER SENSOR	28
FDS1, FDS2	FUSED DISCONNECT SWITCH	4, 5
FS	FLOW SWITCH	38
FTB1	FAN TERMINAL BLOCK	16
FV	CONTROL CIRCUIT FUSE	36
HGBS	HOT GAS BYPASS SOLENOID	48
HGBT	HOT GAS BYPASS TIMER	40
HPD1, HPD2	HIGH PRESSURE CUTOFF	42, 52
HV	HIGH VOLTAGE TERMINAL BLOCK	9
HTB	HEAT TAP TERMINAL BLOCK	5, 9
LAST1, LAST2	LOW AMBIENT START TIMER	47, 58
LWS	LEAVING CHILLER WATER SENSOR	28
LPD1, LPD2	LOW PRESSURE CUTOFF	42, 52
LFT1, LFT2	LOW VOLTAGE TERMINAL BLOCK	
LTC	LOW TEMPERATURE CUTOFF	36
ODF	OUTDOOR FAN RELAY	47
ODM1	OUTDOOR FAN MOTOR	15
RR1, RR2	RESET RELAY	41, 51
TSM	TCM MODULE	24, 38, 50
TNS1	CONTROL POWER TRANSFORMER	33
TNS2	TCM POWER SPLY TRANSFORMER	32
WT	WATER TEMP T-STAT (2 STEP)	44

**WARNING**  
DISCONNECT ELECTRIC POWER SUPPLY BEFORE SERVICING TO PREVENT INJURY OR DEATH DUE TO ELECTRICAL SHOCK.

**AVERTISSEMENT**  
DÉBRANCHER DU CIRCUIT D'ALIMENTATION ÉLECTRIQUE AVANT L'ENTRETIEN POUR ÉVITER BLESSURE OU MORT PAR ÉLECTROCUTION.

**CAUTION**  
USE COPPER CONDUCTORS ONLY TO PREVENT EQUIPMENT DAMAGE. UNIT TERMINALS ARE NOT DESIGNED TO ACCEPT ANY OTHER WIRING.

**ATTENTION**  
UTILISER SEULEMENT DES CONDUCTEURS EN CUIVRE POUR ÉVITER D'ENDOMMAGER L'ÉQUIPEMENT. LES BORNES NE SONT PAS PRÉVUES POUR AUTRES TYPES DE FILS CONDUCTEURS.

(Continued on next page)

NOTES:

1. UNLESS OTHERWISE NOTED, ALL SWITCHES ARE SHOWN AT 25°C (77°F), AT ATMOSPHERIC PRESSURE, AT 50% RELATIVE HUMIDITY, WITH ALL UTILITIES TURNED OFF AND AFTER A NORMAL SHUTDOWN HAS OCCURRED.
2. DASHED LINE INDICATE RECOMMENDED FIELD WIRING BY OTHERS, DASHED LINE ENCLOSURES AND/OR BASHED DEVICE OUTLINES INDICATE COMPONENTS PROVIDED BY THE FIELD. PHANTOM LINE ENCLOSURES INDICATE ALTERNATE CONSTRUCTION CIRCUITRY OR AVAILABLE FIELD INSTALLED ACCESSORIES. SOLID LINE INDICATES WIRING BY TRAME CO.
3. NUMBERS ALONG THE RIGHT SIDE OF THE SCHEMATIC DESIGNATE THE LOCATION OF CONTACTS BY LINE NUMBER. AN UNDERLINED NUMBER INDICATES A NORMALLY CLOSED CONTACT, AN OPEN ARROWHEAD BELOW THE LINE NUMBER POINTING UPWARD INDICATES A TIMED CONTACT WHICH BEGINS TIMING WHEN ENERGIZED.

4. FOR CANADIAN INSTALLATION (CSA) ONLY. LOCAL INSPECTION AUTHORITIES MAY REQUIRE SINGLE POWER SOURCE DISCONNECTING MEANS.
5. WHEN ICS INTERFACE ACCESSORY IS INSTALLED, REMOVE JUMPS BETWEEN LTB1-9 & LTB1-10 AND LTB1-11 & 12.
6. CONNECTIONS SHOWN ARE FOR 230V OPERATION. WHEN 200V OPERATION IS REQUIRED, SWITCH RED AND ORANGE TRANSFORMER LEADS AROUND AT TRANSFORMER TMS. ISOLATE THIS RED WIRE LEAD TO AVOID ACCIDENTLY SHEDDING AT TRANSFORMER TMS. SWITCH WIRE 12 FROM TERMINAL 230V TO TERMINAL 200V.
7. LOW VOLTAGE WIRING MUST BE 18 AWG MINIMUM UNLESS OTHERWISE NOTED.
8. ALTERNATE CONSTRUCTION (FACTORY INSTALLED ONLY).
9. ACCESSORY (IF FIELD INSTALLED ONLY).
10. TCM IS NOT INCLUDED IN THE ICS INTERFACE ACCESSORY.

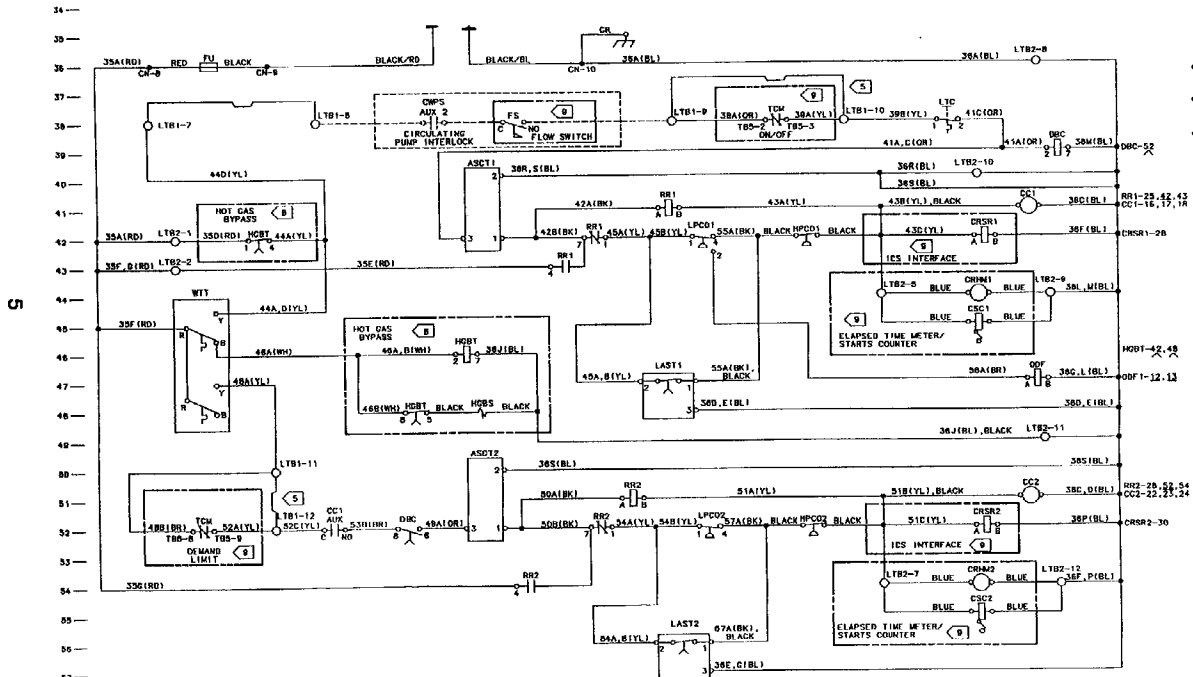

WIRE COLOR DESIGNATION			
ABBR	COLOR	ABBR	COLOR
BK	BLACK	OR	ORANGE
BL	BLUE	WD	WIRE
BR	BROWN	WH	WHITE
GR	GREEN	YL	YELLOW



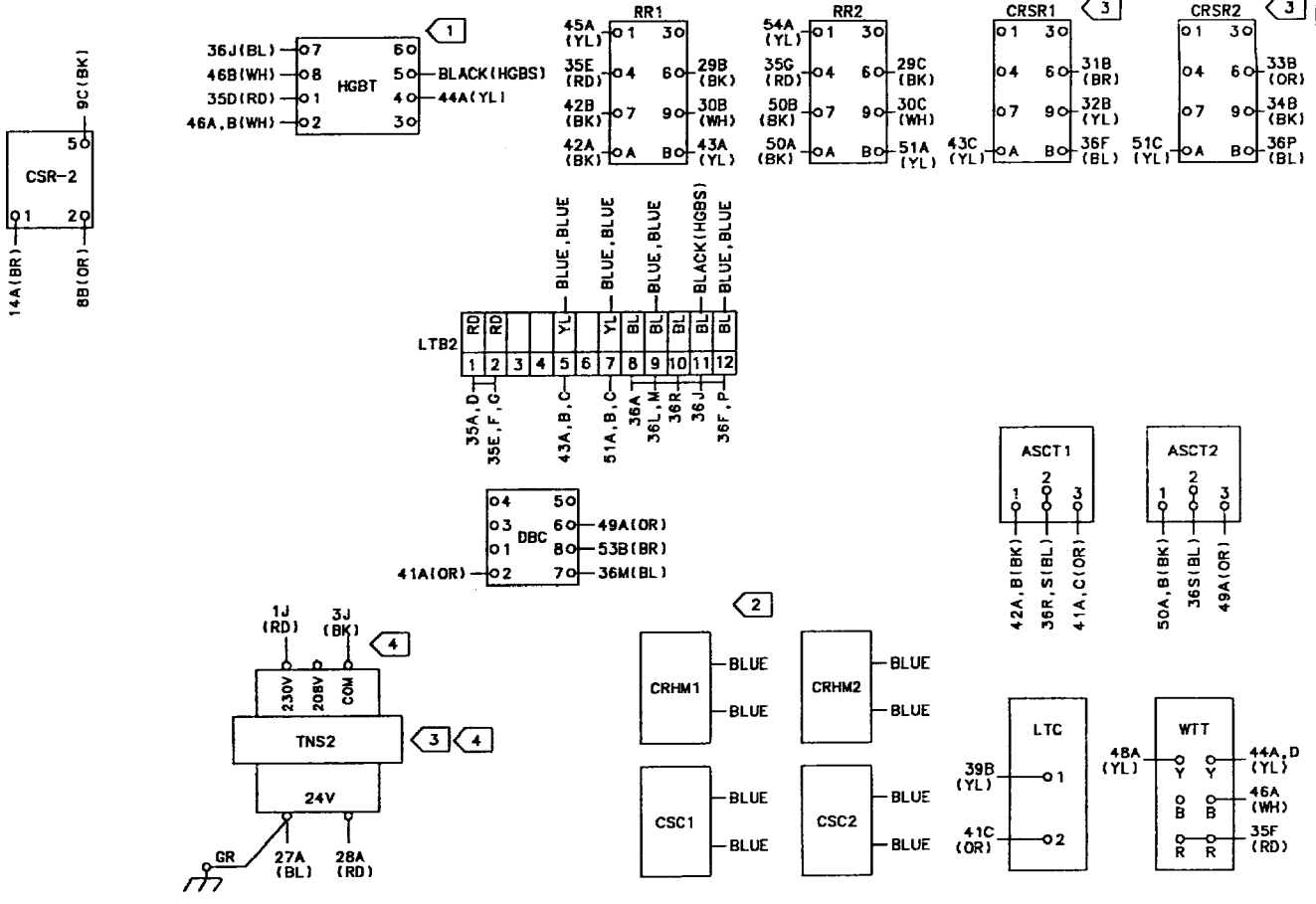

NOTES:

- ① HOT GAS BYPASS ALTERNATE CONSTRUCTION INCLUDES HGBT, HGBS AND ASSOCIATED WIRING (FACTORY INSTALLED ONLY).
- ② FIELD INSTALLED ELAPSED TIME METER AND START COUNTER ACCESSORIES.
- ③ FIELD INSTALLED INTEGRATED COMFORT SYSTEM INTERFACE ACCESSORY. REMOVE JUMPERS BETWEEN LTB1-9 & LTB1-10 AND LTB1-11 & LTB1-12 WHEN INSTALLED.
- ④ CONNECTIONS SHOWN ARE FOR 230V OPERATION. WHEN 208V OPERATION IS REQUIRED, SWITCH RED AND ORANGE TRANSFORMER LEADS AROUND AT TRANSFORMER TNS1. INSULATE TNS1 RED WIRE LEAD TO AVOID ACCIDENTLY SHORTING. AT TRANSFORMER TNS2, SWITCH WIRE 1J(RD) FROM TERMINAL 230V TO TERMINAL 208V.

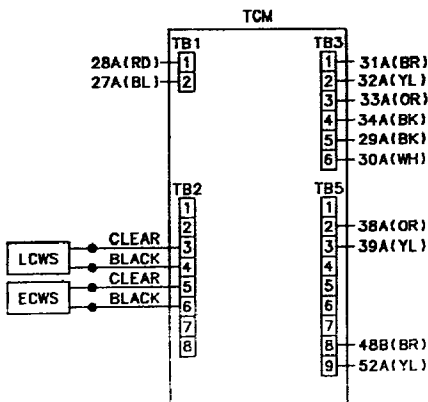
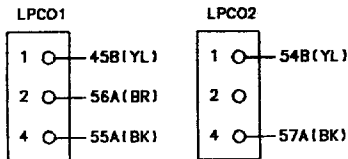

<p><b>⚠ WARNING</b></p> <p>DISCONNECT ELECTRIC POWER SUPPLY BEFORE SERVICING TO PREVENT INJURY OR DEATH DUE TO ELECTRICAL SHOCK.</p> <p><b>AVERTISSEMENT</b></p> <p>DEBRANCHER DU CIRCUIT D'ALIMENTATION ELECTRIQUE AVANT L'ENTRETIEN POUR EVITER BLESSURE OU MORT PAR ELECTROCUTION.</p>	<p><b>⚠ CAUTION</b></p> <p>USE COPPER CONDUCTORS ONLY TO PREVENT EQUIPMENT DAMAGE. UNIT TERMINALS ARE NOT DESIGNED TO ACCEPT ANY OTHER WIRING.</p> <p><b>ATTENTION</b></p> <p>UTILISER SEULEMENT DES CONDUCTEURS EN CUIVRE POUR EVITER D'ENDOMMAGER L'EQUIPEMENT. LES BORNES NE SONT PAS PREVUES POUR AUTRES TYPES DE FILS CONDUCTEURS.</p>
-------------------------------------------------------------------------------------------------------------------------------------------------------------------------------------------------------------------------------------------------------------------------------------------	---------------------------------------------------------------------------------------------------------------------------------------------------------------------------------------------------------------------------------------------------------------------------------------------------------------------------------------------

**Figure 3**  
CGA120B3  
(208-230V/60/3) Schematic Diagram

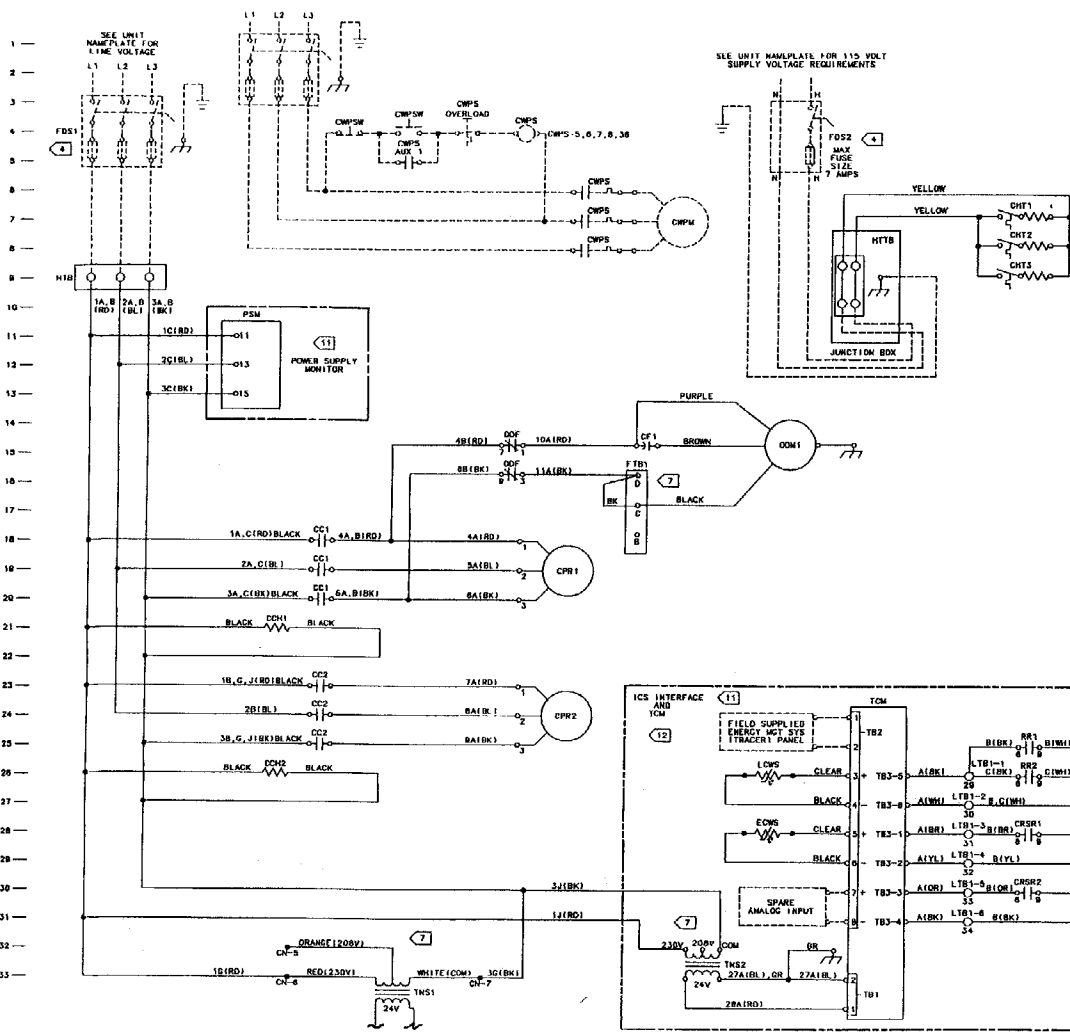

DEVICE DESIGNATION	DESCRIPTION	LINE NUMBER
ACT1,ACT2	ANTI-SHORT CYCLE TIMER	40,50
CC1,CC2	COMPRESSOR CONTACTOR	41,51
CCM1,CCM2	CRANKCASE HEATL	21,28
CF1	OUTDOOR FAN CAPACITOR	15
CHT1,CHT2,CHT3	CHILLER HEAT TAPE	7,8,9
CM	CONTACTOR OR WIRE NUT	7
CPR1,CPR2	COMPRESSOR	19,24
CRM1,CRM2	COMPRESSOR RUN HOUR METER	44,54
CRSR1,CRSR2	COMPRESSOR RUN STATUS RELAY	42,52
CCCT,CCCT2	COMPRESSOR START COUNTER	45,55
CWPM	CHILLER WATER PUMP MOTOR	7
CWPS	CHILLER WATER PUMP STARTER	6
CWPSW	CHILLER WATER PUMP SWITCH	4
DRD	DELAY BETWEEN COMPRESSORS	38
ECWS	ENTERING CHILLED WATER SENSOR	28
FBS1,FBS2	FUSED DISCONNECT SWITCH	4,4
FS	FLOW SWITCH	36
FTB1	FAN TERMINAL BLOCK	19,17,18
F3	CONTROL CIRCUIT FUSE	38
HBS9	HOT GAS BYPASS SOLENOID	40
HBT	HEAT TAPE TERMINAL BLOCK	8,8,10
HPD1,HPD2	HIGH PRESSURE CUTOFF	42,52
HTD	HIGH VOLTAGE TERMINAL BLOCK	8
HTTB	HEAT TAPE TERMINAL BLOCK	8,8,10
LAST1, LAST2	LOW AMBIENT START TIMER	47,58
LEWS	LEAVING CHILLED WATER SENSOR	28
LPD1,LPD2	LOW PRESSURE CUTOFF	42,52
LTB1,LTB2	LOW VOLTAGE TERMINAL BLOCK	38
LTC	LOW TEMPERATURE CUTOFF	38
ODF	OUTDOOR FAN RELAY	4,7
ODM1	OUTDOOR FAN MOTOR	15
PSM	POWER SUPPLY MONITOR	11,12,13
RR1,RR2	RESET RELAY	41,51
TCM	TCM MODULE	24,38,52
TNS1	CONTROL POWER TRANSFORMER	33
TNS2	TCM POWER SPL TRANSFORMER	32
TNT	WATER TEMP T-STAT (2 STEP)	44

**WARNING**  
DISCONNECT ELECTRIC POWER SUPPLY BEFORE SERVICING TO PREVENT INJURY OR DEATH DUE TO ELECTRICAL SHOCK.

**AVERTISSEMENT**  
DERRANCHER DU CIRCUIT D'ALIMENTATION ELECTRIQUE AVANT L'ENTRÉE EN FONCTIONNEMENT POUR ÉVITER BLESSURE OU MORT PAR ÉLECTROCUTION.

**CAUTION**  
USE COPPER CONDUCTORS ONLY TO PREVENT EQUIPMENT DAMAGE. UNIT TERMINALS ARE NOT DESIGNED TO ACCEPT ANY OTHER WIRING.

**ATTENTION**  
UTILISER SEULEMENT DES CONDUCTEURS EN CUIVRE POUR ÉVITER D'ENDOMMAGER L'ÉQUIPEMENT. LES BORNES NE SONT PAS PRÉVUES POUR AUTRES TYPES DE FILS CONDUCTEURS.

(Continued on next page)



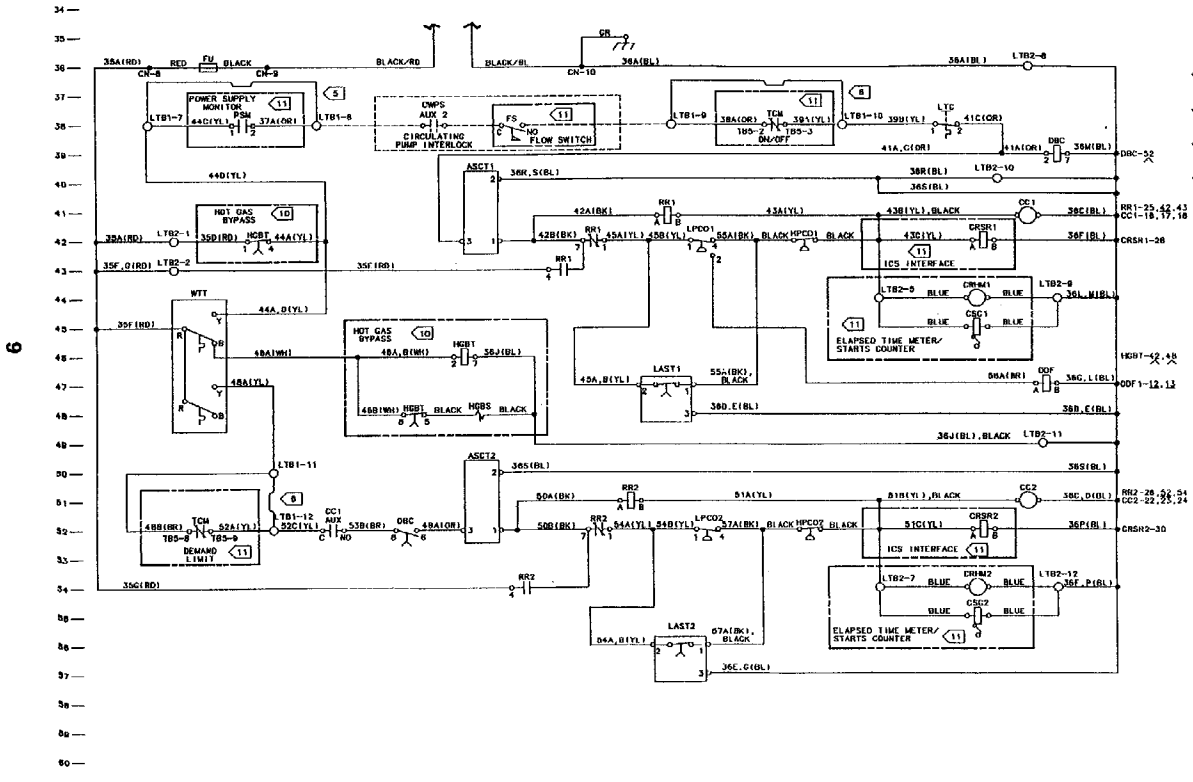

- NOTES:
1. UNLESS OTHERWISE NOTED, ALL SWITCHES ARE SHOWN AT 25°C (77°F) AT ATMOSPHERIC PRESSURE, AT 50% RELATIVE HUMIDITY WITH ALL UTILITY LEADS OPEN AND AFTER A NORMAL SHUTDOWN HAS OCCURRED.
  2. DASHED LINES INDICATE RECOMMENDED FIELD WIRING BY OTHERS. DASHED LINE INDICATES AND/OR DASHED IN PLACE OUTLINES INDICATE COMPONENTS PROVIDED BY THE FIELD. PHANTOM LINE ENCLOSURES INDICATE ALTERNATE CONSTRUCTION INCLUDING ON AVAILABLE FIELD INSTALLED ACCESSORIES. SOLID LINE INDICATES WIRING BY TRANE CO.
  3. NUMBERS ALONG THE RIGHT SIDE OF THE SCHEMATIC DE SIGNIFY THE LOCATION OF CONTACTS BY LINE NUMBER. AN UNDERLINED NUMBER INDICATES A NORMALLY CLOSED CONTACT. AN OPEN ARROWHEAD BELOW THE LINE NUMBER POINTING UPWARD INDICATES A TIMED CONTACT WHICH BEGINS TIMING WHEN ENERGIZED.
- 4 FOR CANADIAN INSTALLATION (CSA) ONLY. LOCAL INSPECTION AUTHORITIES MAY REQUIRE SINGLE POWER SOURCE DISCONNECTING MEANS.  
 5 WHEN POWER SUPPLY MONITOR ACCESSORY IS INSTALLED, REMOVE JUMPER BETWEEN LTB1-7 AND LTB1-8.  
 6 WHEN ICS INTERFACE ACCESSORY IS INSTALLED, REMOVE JUMPER BETWEEN LTB1-9 & LTB1-10 AND LTB1-11 & 12.  
 7 CONNECTIONS SHOWN ARE FOR 230V OPERATION. WHEN 208V OPERATION IS REQUIRED, SWITCH RED AND ORANGE TRANSFORMER LEADS AROUND AT TRANSFORMER TAP. ISOLATE HOT WIRE LEAD TO AVOID ACCIDENTLY SHORTING AT TRANSFORMER TAP. SWITCH WIRE 15 FROM TERMINAL 230V TO TERMINAL 208V.  
 8 ALL THREE PHASE MOTORS SUPPLIED WITH THE UNIT ARE PROTECTED UNDER PRIMARY SINGLE PHASE FAILING CONDITIONS.  
 9 LOW VOLTAGE WIRING MUST BE 18 AWG MINIMUM.  
 10 ALTERNATE CONSTRUCTION (FACTORY INSTALLED ONLY).  
 11 ACCESSORY (FIELD INSTALLED ONLY).  
 12 TCM IS NOT INCLUDED IN THE ICS INTERFACE ACCESSORY.

WIRE COLOR DESIGNATION			
ABBR	COLOR	ABBR	COLOR
BK	BLACK	OR	ORANGE
BL	BLUE	RD	RED
BR	BROWN	WH	WHITE
GR	GREEN	YL	YELLOW

**Figure 4**  
**CGA120B3**  
**(208-230V/60/3) Connection Diagram**

(Continued on next page)

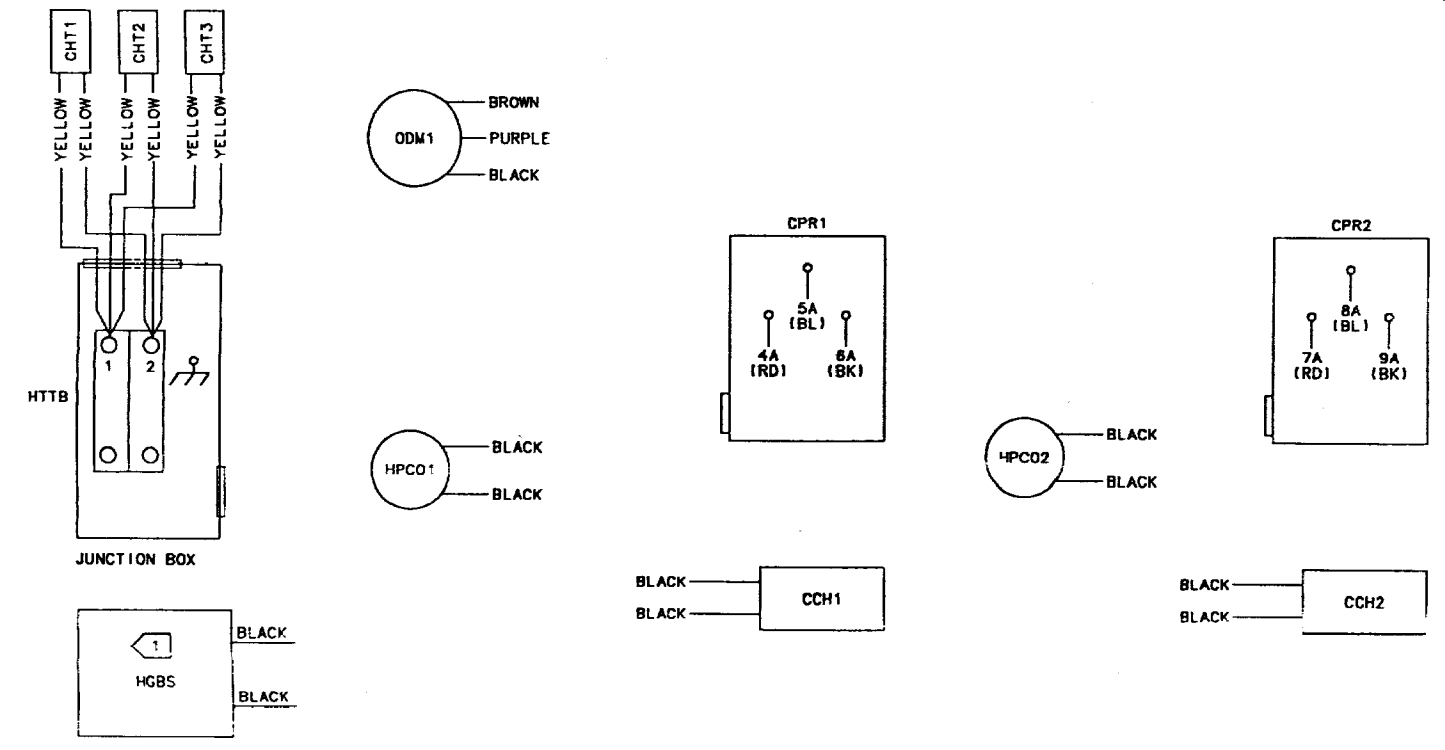
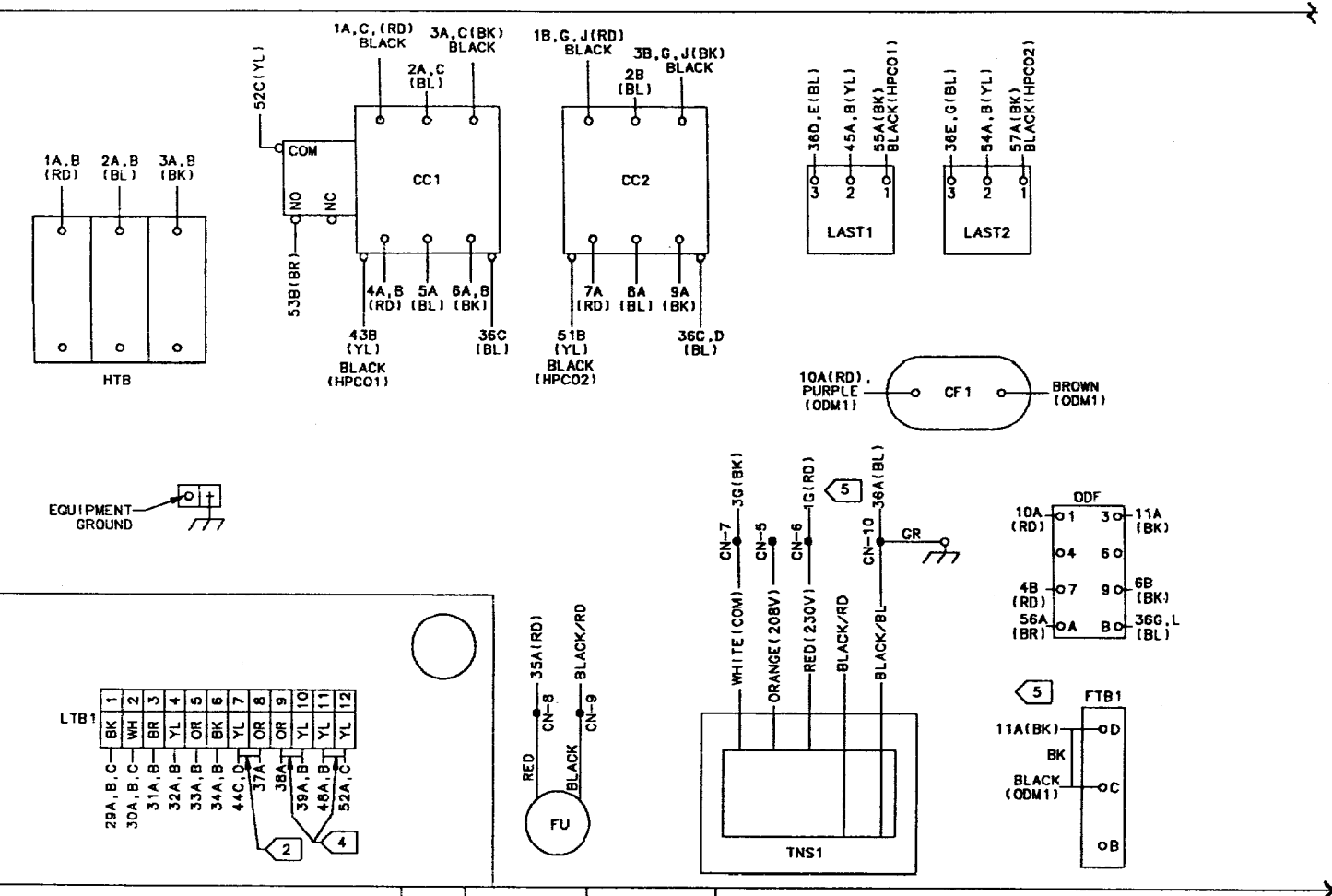

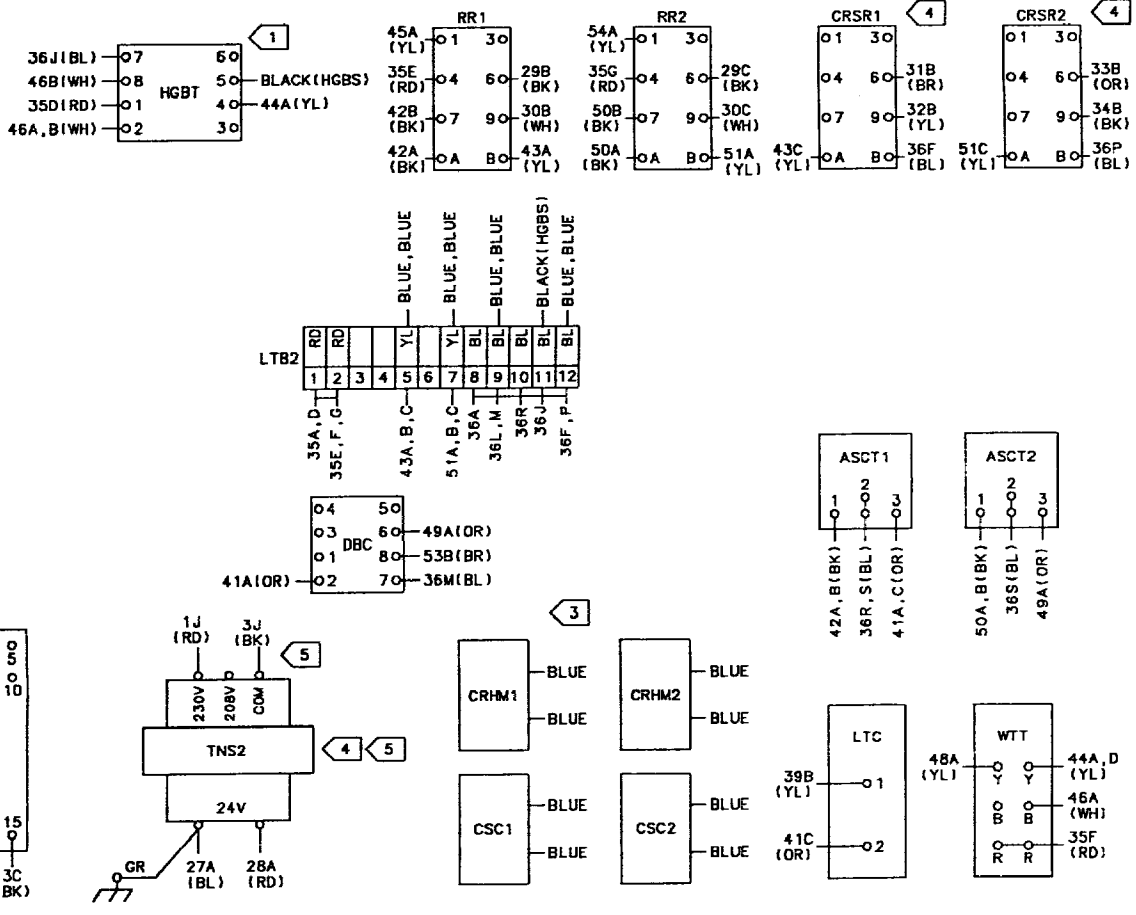

NOTES:

- ① HOT GAS BYPASS ALTERNATE CONSTRUCTION INCLUDES HGBT, HGBS AND ASSOCIATED WIRING (FACTORY INSTALLED ONLY).
- ② FIELD INSTALLED POWER SUPPLY MONITOR ACCESSORY. REMOVE JUMPER BETWEEN LTB1-7 AND LTB1-8 WHEN INSTALLED.
- ③ FIELD INSTALLED ELAPSED TIME METERS AND START COUNTER ACCESSORIES.
- ④ FIELD INSTALLED INTEGRATED COMFORT SYSTEM INTERFACE ACCESSORY. REMOVE JUMPERS BETWEEN LTB1-9 & LTB1-10 AND LTB1-11 & LTB1-12 WHEN INSTALLED.
- ⑤ CONNECTIONS SHOWN ARE FOR 230V OPERATION. WHEN 208V OPERATION IS REQUIRED, SWITCH RED AND ORANGE TRANSFORMER LEADS AROUND AT TRANSFORMER TNS1. INSULATE TNS1 RED WIRE LEAD TO AVOID ACCIDENTLY SHORTING. AT TRANSFORMER TNS2, SWITCH WIRE 1J(RD) FROM TERMINAL 230V TO TERMINAL 208V.

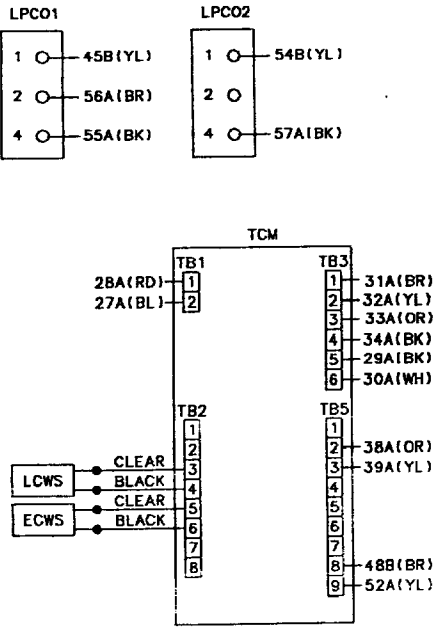

<p><b>⚠ WARNING</b></p> <p>DISCONNECT ELECTRIC POWER SUPPLY BEFORE SERVICING TO PREVENT INJURY OR DEATH DUE TO ELECTRICAL SHOCK.</p> <p><b>AVERTISSEMENT</b></p> <p>DEBRANCHER DU CIRCUIT D'ALIMENTATION ELECTRIQUE AVANT L'ENTRETIEN POUR EVITER BLESSURE OU MORT PAR ELECTROCUTION.</p>	<p><b>⚠ CAUTION</b></p> <p>USE COPPER CONDUCTORS ONLY TO PREVENT EQUIPMENT DAMAGE. UNIT TERMINALS ARE NOT DESIGNED TO ACCEPT ANY OTHER WIRING.</p> <p><b>ATTENTION</b></p> <p>UTILISER SEULEMENT DES CONDUCTEURS EN CUIVRE POUR EVITER D'ENDOMMAGER L'EQUIPEMENT. LES BORNES NE SONT PAS PREVUES POUR AUTRES TYPES DE FILS CONDUCTEURS.</p>
-------------------------------------------------------------------------------------------------------------------------------------------------------------------------------------------------------------------------------------------------------------------------------------------	---------------------------------------------------------------------------------------------------------------------------------------------------------------------------------------------------------------------------------------------------------------------------------------------------------------------------------------------

**Figure 5**  
**CGA120B4 (460V/60/3) and**  
**CGA120BW (575V/60/3) Schematic Diagram**

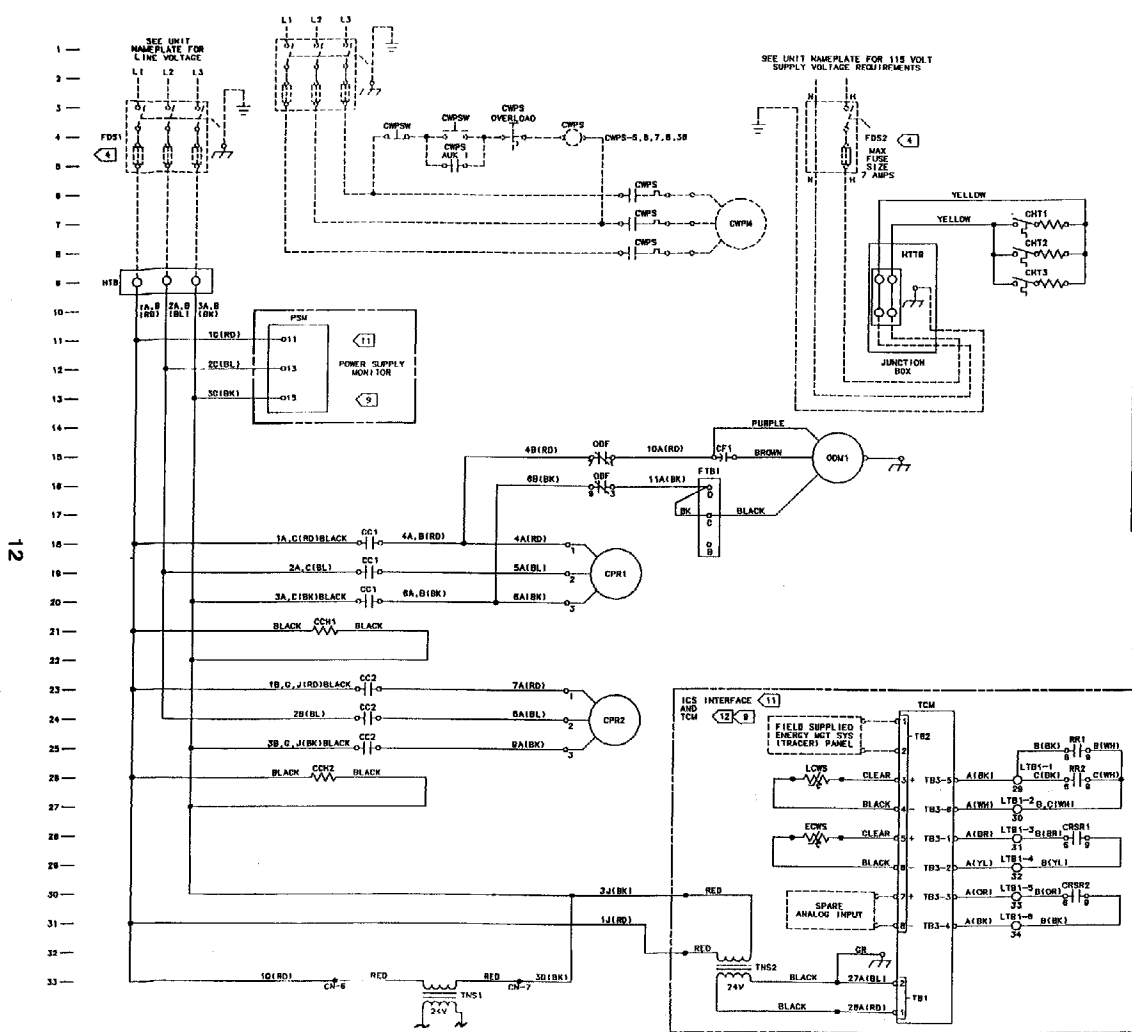

DEVICE DESIGNATION	DESCRIPTION	LINE NUMBER
ASCT1,ASCT2	ANTI-SHORT CYCLE TIMER	40,50
CC1,CC2	COMPRESSOR CONTACTOR	41,51
CH1,CH2	CRANKCASE HEATER	21,26
CF1	OUTDOOR FAN CAPACITOR	15
CH11,CH12,CH13	CHILLER HEAT TAPE	7,8,9
CK	CONNECTOR OR WIRE MAT	
CPH1,CPH2	COMPRESSOR	18,24
CRH1,CRH2	COMPRESSOR RUN HOUR METER	44,54
CRS1,CRS2	COMPRESSOR RUN STATUS RELAY	42,52
CRSL,CRSZ	COMPRESSOR START COILS	15,55
CPW	CHILLER WATER PUMP MOTOR	7
OWS	CHILLER WATER PUMP STARTER	4
OWSW	CHILLER WATER PUMP SWITCH	4
OWC	DELAY BETWEEN COMPRESSORS	39
OWS	ENTERING CHILLED WATER SENSOR	28
FDS1,FDS2	FUSED DISCONNECT SWITCH	4,4
FS	FLOW SWITCH	38
FTB1	FAN TERMINAL BLOCK	18,17,18
FU	CONTROL CIRCUIT FUSE	38
HGS	HOT GAS BYPASS SOLENOID	49
HGBT	HOT GAS BYPASS TIMER	48
HPD1,HPD2	HIGH PRESSURE CUTOFF	42,52
HTB	HIGH VOLTAGE TERMINAL BLOCK	9
HTB	HEAT TAPE TERMINAL BLOCK	8,9,10
LAST1,LAST2	LOW AMBIENT START THER	47,50
LWS	LEAVING CHILLED WATER SENSOR	28
LPCD1,LPCD2	LOW PRESSURE CUTOFF	42,52
LTB1,LTB2	LOW VOLTAGE TERMINAL BLOCK	11,12,13
LTC	LOW TEMPERATURE CUTOFF	39
ODF	OUTDOOR FAN RELAY	47
ODM1	OUTDOOR FAN MOTOR	15
PSM	POWER SUPPLY MONITOR	11,12,13
RRT,RBZ	RESET RELAY	41,51
TCM	TCM MODULE	24,38,52
TNS1	CONTROL POWER TRANSFORMER	33
TNS2	TCM POWER SPLY TRANSFORMER	32
WT	WATER TEMP 1-STAT 12-STEP	44

**⚠ WARNING**  
 DISCONNECT ELECTRIC POWER SUPPLY BEFORE SERVICING TO PREVENT INJURY OR DEATH DUE TO ELECTRICAL SHOCK.

**AVERTISSEMENT**  
 DEBRANCHER DU CIRCUIT D'ALIMENTATION ELECTRIQUE AVANT L'ENTRETIEN POUR EVITER BLESSURE OU MORT PAR ELECTROCUTION.

**⚠ CAUTION**  
 USE COPPER CONDUCTORS ONLY TO PREVENT EQUIPMENT DAMAGE. UNIT TERMINALS ARE NOT DESIGNED TO ACCEPT ANY OTHER WIRING.

**ATTENTION**  
 UTILISER SEULEMENT DES CONDUCTEURS EN CUIVRE POUR EVITER D'ENDOMMAGER L'EQUIPEMENT. LES BORNES NE SONT PAS PREVUES POUR AUTRES TYPES DE FILS CONDUCTEURS.

(Continued on next page)

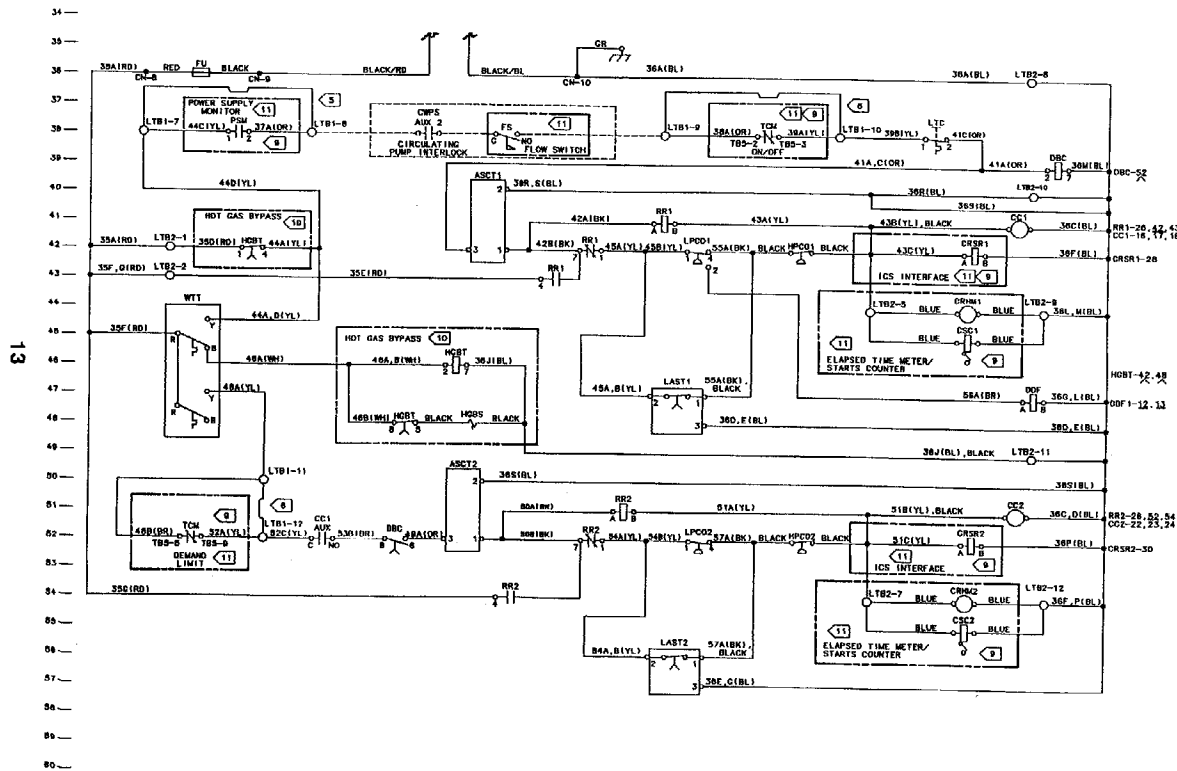

- NOTES:
- UNLESS OTHERWISE NOTED, ALL SWITCHES ARE SHOWN AT 25°C (77°F), AT ATMOSPHERIC PRESSURE, AT 50% RELATIVE HUMIDITY. WITH ALL UTILITIES TURNED OFF, AND AFTER A NORMAL SHUTDOWN HAS OCCURRED.
  - DASHED LINES INDICATE RECOMMENDED FIELD WIRING BY OTHERS. DASHED LINE ENCLOSURES AND/OR DASHED DEVICE OUTLINES INDICATE COMPONENTS PROVIDED BY THE FIELD. PHANTOM LINE ENCLOSURES INDICATE ALTERNATE CONSTRUCTION CIRCUITRY OR AVAILABLE FIELD INSTALLED ACCESSORIES. SOLID LINE INDICATES WIRING BY TRANE, CO.
  - NUMBERS ALONG THE RIGHT SIDE OF THE SCHEMATIC DESIGNATE THE LOCATION OF CONTACTS BY LINE NUMBER. AN UNDERLINED NUMBER INDICATES A NORMALLY CLOSED CONTACT. AN OPEN ARROWHEAD BELOW THE LINE NUMBER POINTING UPWARD INDICATES A TIMED CONTACT WHICH BEGINS TIMING WHEN ENERGIZED.
  - FOR CANADIAN INSTALLATION (CSA) ONLY. LOCAL INSPECTION AUTHORITIES MAY REQUIRE SINGLE POWER SOURCE DISCONNECTING MEANS.
  - WHEN POWER SUPPLY MONITOR ACCESSORY IS INSTALLED, REMOVE JUMPER BETWEEN LTB1-7 AND LTB1-8.
  - WHEN ICS INTERFACE ACCESSORY IS INSTALLED, REMOVE JUMPER BETWEEN LTB1-9 & LTB1-10 AND LTB1-11 & 12.
  - ALL THREE PHASE MOTORS SUPPLIED WITH THE UNIT ARE PROTECTED UNDER PRIMARY SINGLE PHASE FAILURE CONDITIONS.
  - LOW VOLTAGE WIRINGS MUST BE 18 AWG MINIMUM.
  - ACCESSORIES ARE NOT AVAILABLE FOR 36P-10 W/50 HZ/3 P - 1 W/50 HZ/3 P.
  - ALTERNATE CONSTRUCTION (FACTORY INSTALLED ONLY).
  - ACCESSORY (FIELD INSTALLED ONLY).
  - TOM IS NOT INCLUDED IN THE ICS INTERFACE ACCESSORY.

WIRE COLOR DESIGNATION			
ASBN	COLOR	LABSN	COLOR
BK	BLACK	OR	ORANGE
BL	BLUE	RD	RED
BR	BROWN	WH	WHITE
GR	GREEN	YL	YELLOW

**Figure 6**  
**CGA120B4 (460V/60/3) and**  
**CGA120BW (575V/60/3) Connection Diagram**

(Continued on next page)

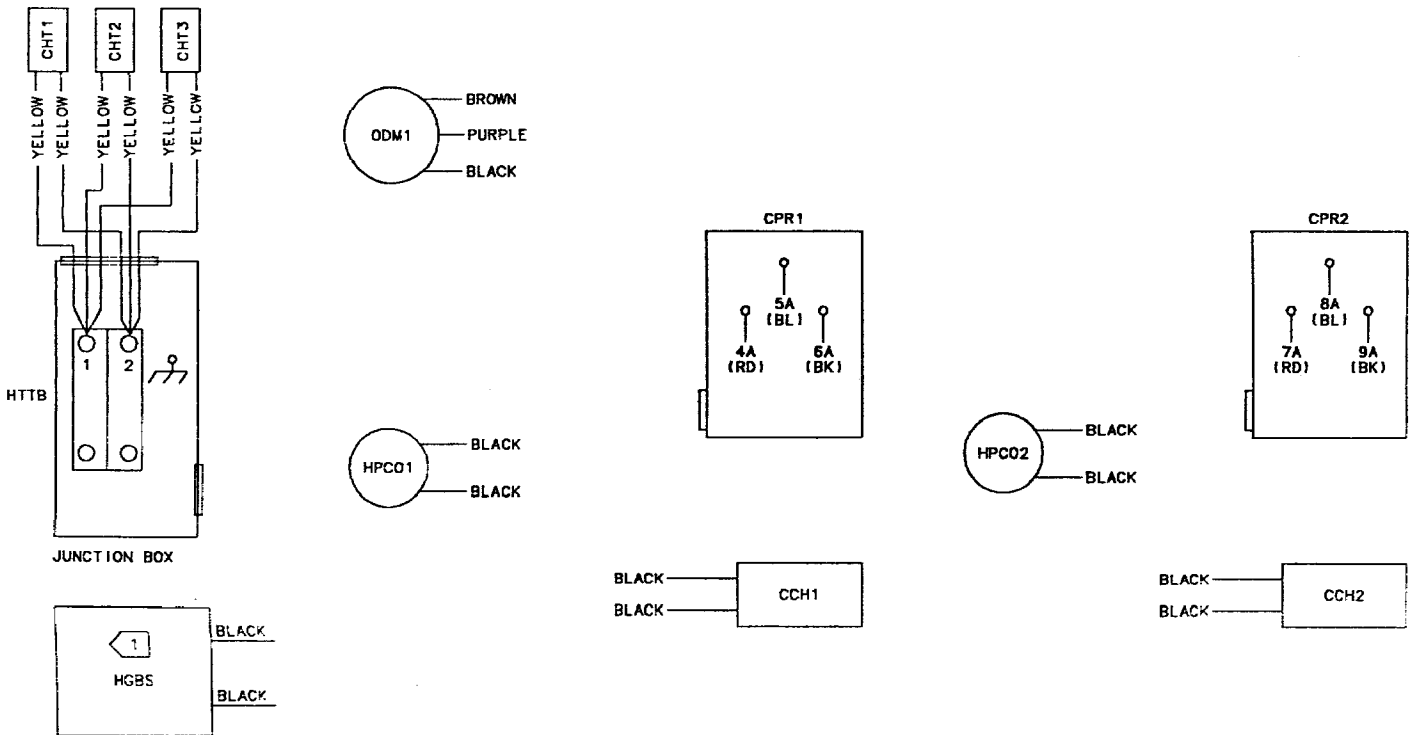
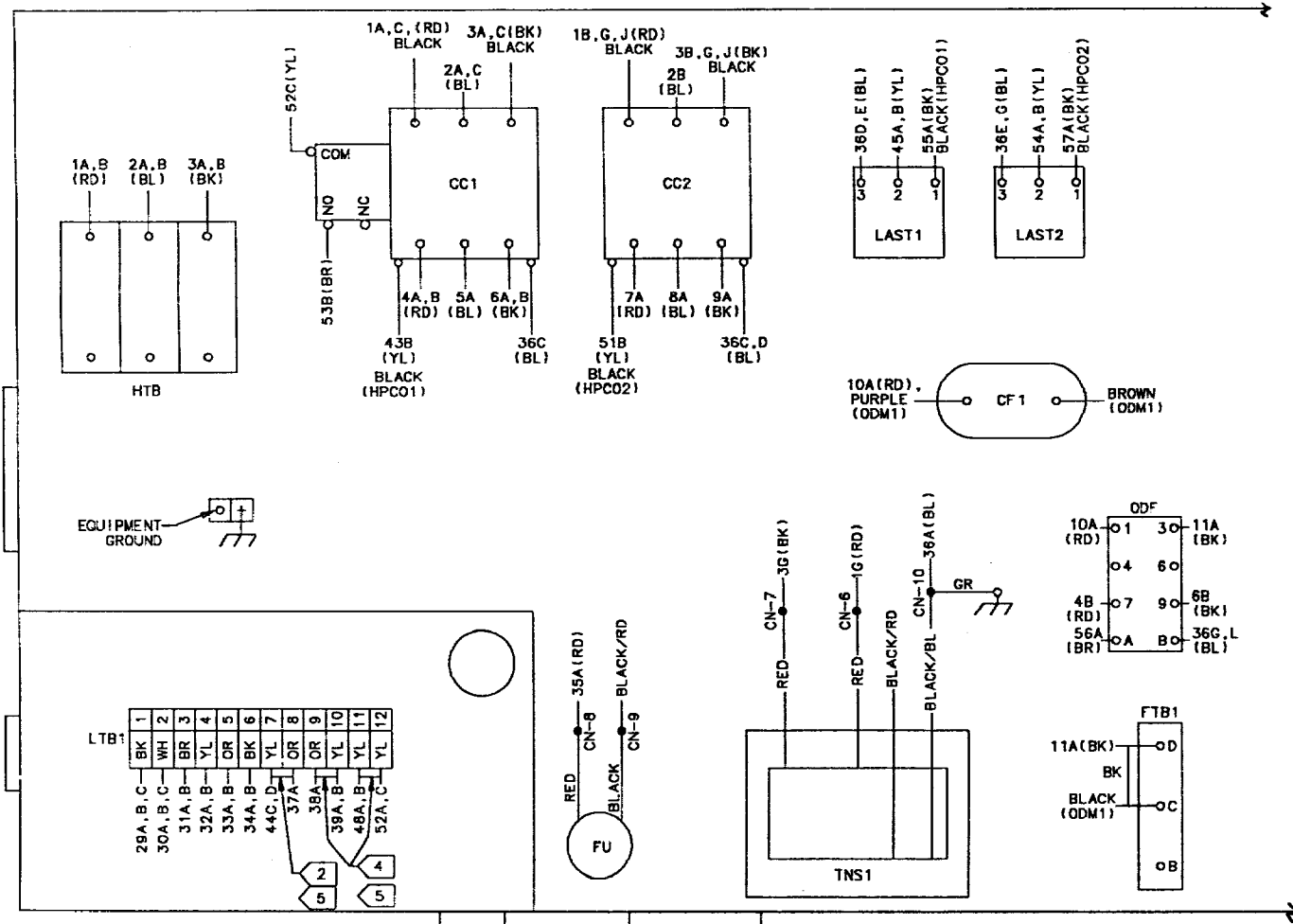

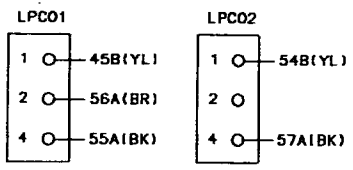
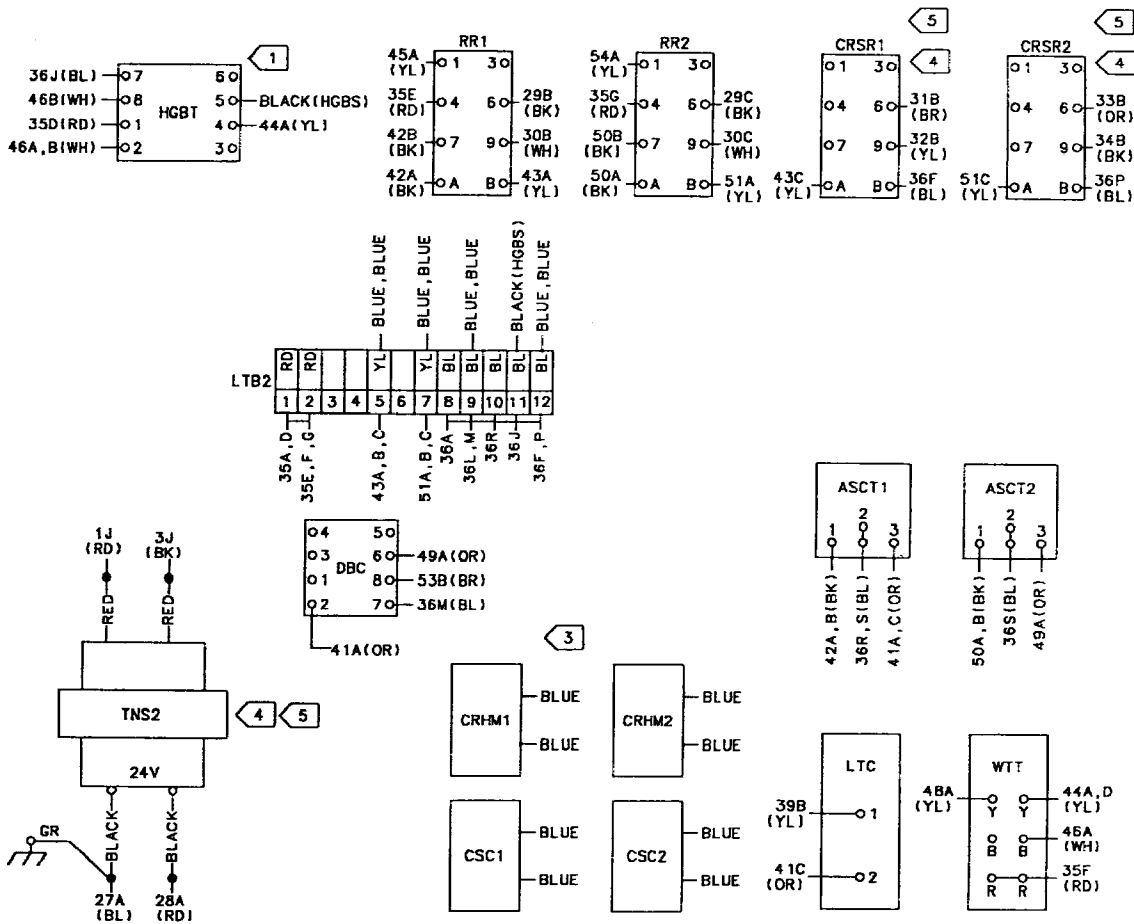

NOTES:

- 1 HOT GAS BYPASS ALTERNATE CONSTRUCTION INCLUDES HGBT, HGBS AND ASSOCIATED WIRING (FACTORY INSTALLED ONLY).
- 2 FIELD INSTALLED POWER SUPPLY MONITOR ACCESSORY. REMOVE JUMPER BETWEEN LTB1-7 AND LTB1-8 WHEN INSTALLED.
- 3 FIELD INSTALLED ELAPSED TIME METER AND START COUNTER ACCESSORIES.
- 4 FIELD INSTALLED INTEGRATED COMFORT SYSTEM INTERFACE ACCESSORY. REMOVE JUMPERS BETWEEN LTB1-9 & LTB1-10 AND LTB1-11 & LTB1-12 WHEN INSTALLED.
- 5 THIS ACCESSORY NOT AVAILABLE FOR 380-415V./50 HZ./3 PHASE UNIT APPLICATION.

<p><b>⚠ WARNING</b></p> <p>DISCONNECT ELECTRIC POWER SUPPLY BEFORE SERVICING TO PREVENT INJURY OR DEATH DUE TO ELECTRICAL SHOCK.</p> <p><b>AVERTISSEMENT</b></p> <p>DEBRANCHER DU CIRCUIT D'ALIMENTATION ELECTRIQUE AVANT L'ENTRETIEN POUR EVITER BLESSURE OU MORT PAR ELECTROCUTION.</p>	<p><b>⚠ CAUTION</b></p> <p>USE COPPER CONDUCTORS ONLY TO PREVENT EQUIPMENT DAMAGE. UNIT TERMINALS ARE NOT DESIGNED TO ACCEPT ANY OTHER WIRING.</p> <p><b>ATTENTION</b></p> <p>UTILISER SEULEMENT DES CONDUCTEURS EN CUIVRE POUR EVITER D'ENDOMMAGER L'EQUIPEMENT. LES BORNES NE SONT PAS PREVUES POUR AUTRES TYPES DE FILS CONDUCTEURS.</p>
-------------------------------------------------------------------------------------------------------------------------------------------------------------------------------------------------------------------------------------------------------------------------------------------	---------------------------------------------------------------------------------------------------------------------------------------------------------------------------------------------------------------------------------------------------------------------------------------------------------------------------------------------

Figure 7  
CGA180B3  
(208-230V/60/3) Schematic Diagram

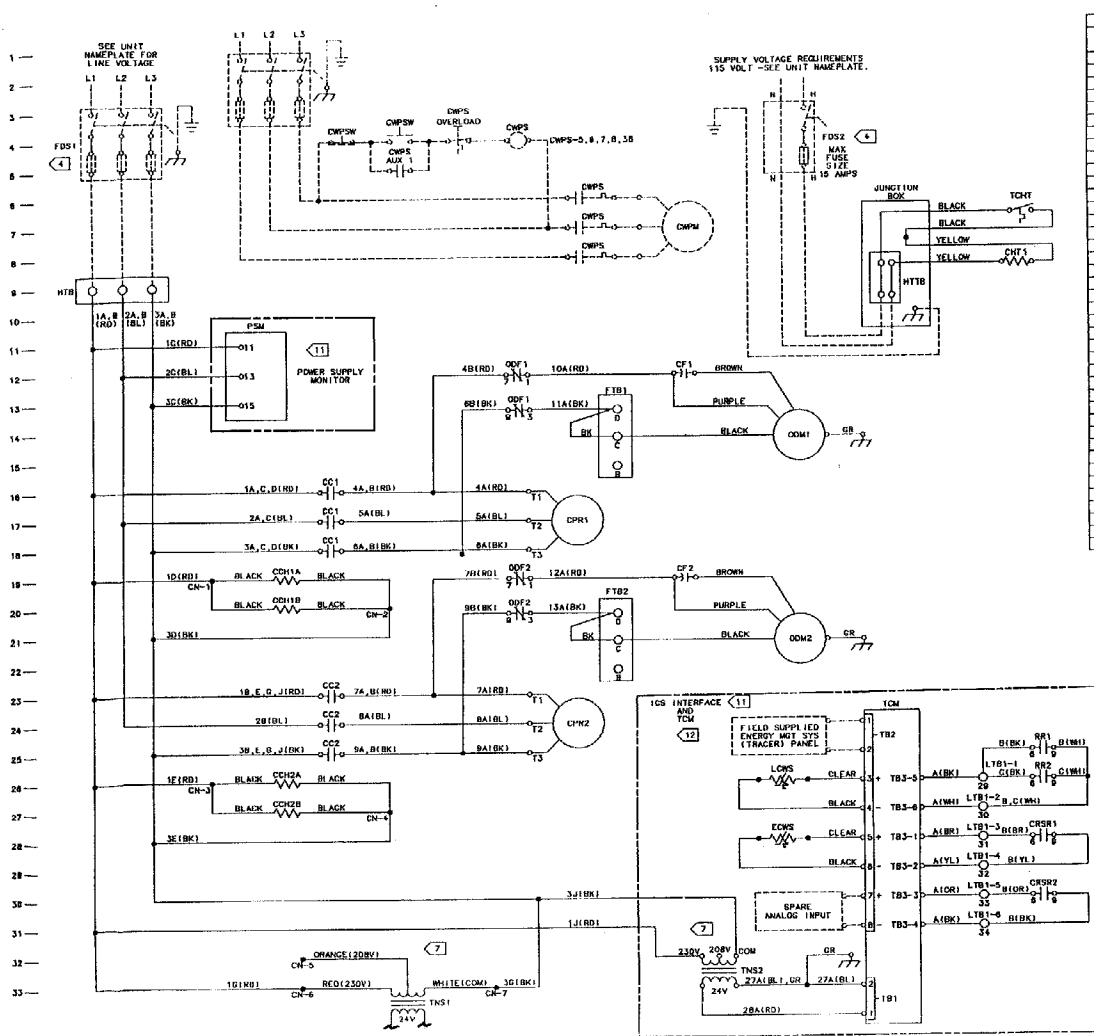

**WARNING**  
DISCONNECT ELECTRIC POWER SUPPLY BEFORE SERVICING TO PREVENT INJURY OR DEATH DUE TO ELECTRICAL SHOCK.

**AVERTISSEMENT**  
DÉBRANCHER DU CIRCUIT D'ALIMENTATION ÉLECTRIQUE AVANT L'ENTRETIEN POUR ÉVITER BLESSURE OU MORT PAR ÉLECTROCUTION.

**CAUTION**  
USE COPPER CONDUCTORS ONLY TO PREVENT EQUIPMENT DAMAGE. UNIT TERMINALS ARE NOT DESIGNED TO ACCEPT ANY OTHER WIRING.

**ATTENTION**  
UTILISER SEULEMENT DES CONDUCTEURS EN CUIVRE POUR ÉVITER D'ENDOMMAGER L'ÉQUIPEMENT. LES BORNES NE SONT PAS PRÉVUES POUR AUTRES TYPES DE FILS CONDUCTEURS.

(Continued on next page)



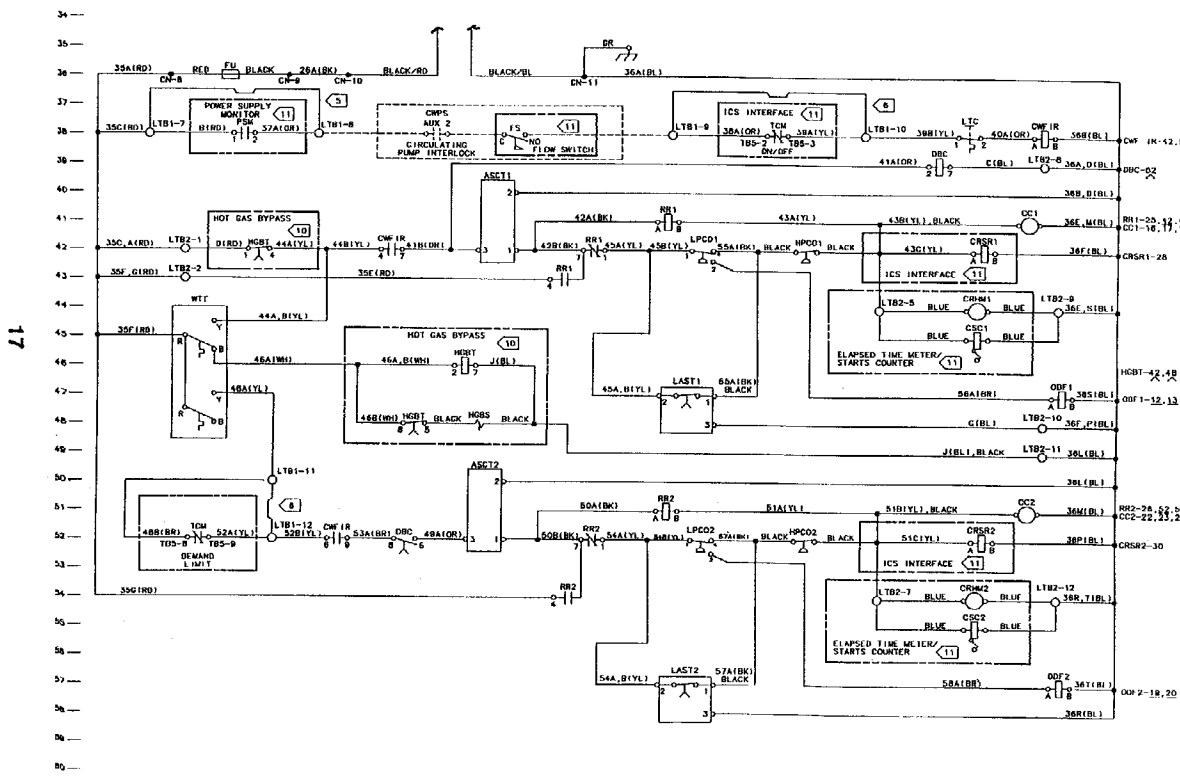

- NOTES:
- UNLESS OTHERWISE NOTED, ALL SWITCHES ARE SHOWN AT 25°C (77°F), AT ATMOSPHERIC PRESSURE, AT 50% RELATIVE HUMIDITY, WITH ALL UTILITIES ENERGIZED, AND AFTER A NORMAL SHUTDOWN HAS OCCURRED.
  - DASHED LINES INDICATE RECOMMENDED FIELD WIRING BY OTHERS. DASHED LINE ENCLOSURES AND/OR DASHED DEVICE OUTLINES INDICATE COMPONENTS PROVIDED BY THE FIELD. PHANTOM LINE ENCLOSURES INDICATE ALTERNATE CONSTRUCTION AVAILABLE IF AVAILABLE FIELD INSTALLED ACCESSORIES. SOLID LINE INDICATES WIRING BY TRANE CO.
  - NUMBERS ALONG THE RIGHT SIDE OF THE SCHEMATIC DESIGNATE THE LOCATION OF CONTACTS BY LINE NUMBER. AN UNDERLINED NUMBER INDICATES A NORMALLY CLOSED CONTACT. AN OPEN ARROWHEAD BELOW THE LINE NUMBER POINTING UPWARD INDICATES A LATCH CONTACT WHICH BEGINS TIMING WHEN ENERGIZED.
- (1) FOR CANADIAN INSTALLATION (CSA) ONLY, LOCAL INSPECTION AUTHORITIES MAY REQUIRE SINGLE POWER SOURCE DISCONNECTING MEANS.  
 (2) WHEN POWER SUPPLY MONITOR IS INSTALLED, RELAY JUMPER BETWEEN LTB1-7 AND LTB1-8.  
 (3) WHEN ICS INTERFACE ACCESSORY IS INSTALLED, RELAY JUMPER BETWEEN LTB1-9 & LTB1-10 AND LTB1-11 & 12.  
 (4) CONNECTIONS SHOWN ARE FOR 230V OPERATION. WHEN 200V OPERATION IS REQUIRED, SWITCH RED, B, AND ORANGE TRANSFORMER LEADS AROUND AT TRANSFORMER INS. INSULATE THIS RED BLUE LEAD TO AVOID ACCIDENTLY SHORTING AT TRANSFORMER TAP. SWITCH WIRE 1 FROM TERMINAL 230V TO TERMINAL 200V.  
 (5) ALL THREE PHASE MOTORS SUPPLIED WITH THE UNIT ARE PROTECTED UNDER PRIMARY SINGLE PHASE FAILURE CONDITIONS.  
 (6) ALTERNATE CONSTRUCTION, FACTORY INSTALLED ONLY.  
 (7) ACCESSORY; FIELD INSTALLED ONLY.  
 (8) ICM IS NOT INCLUDED IN THE ICS INTERFACE ACCESSORY.

WIRE COLOR	DEFINITION
BRK	BLACK
BL	BLUE
OR	ORANGE
RD	RED
WHT	WHITE
GR	GREEN
YL	YELLOW

**Figure 8**  
**CGA180B3**  
**(208-230V/60/3) Connection Diagram**

(Continued on next page)

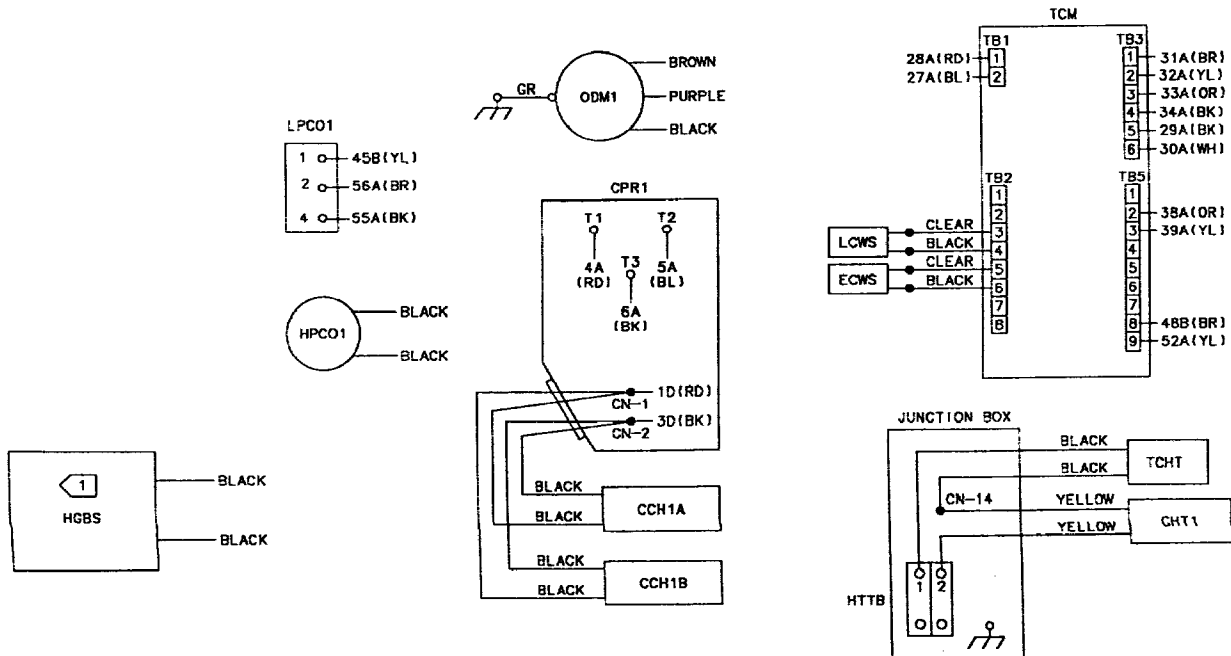
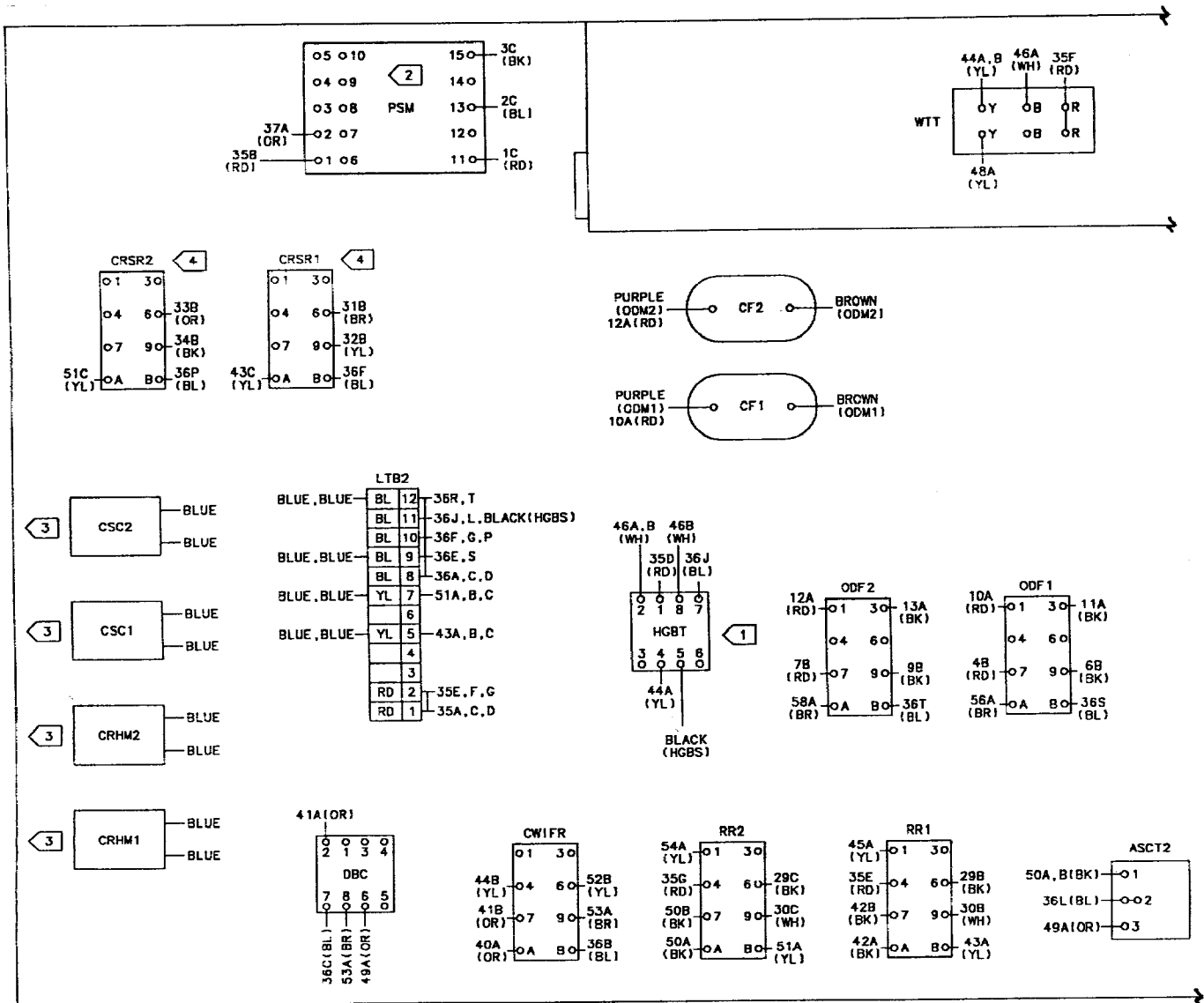



**Figure 9**  
**CGA180B4 (460V/60/3) and**  
**CGA180BW (575V/60/3) Schematic Diagram**

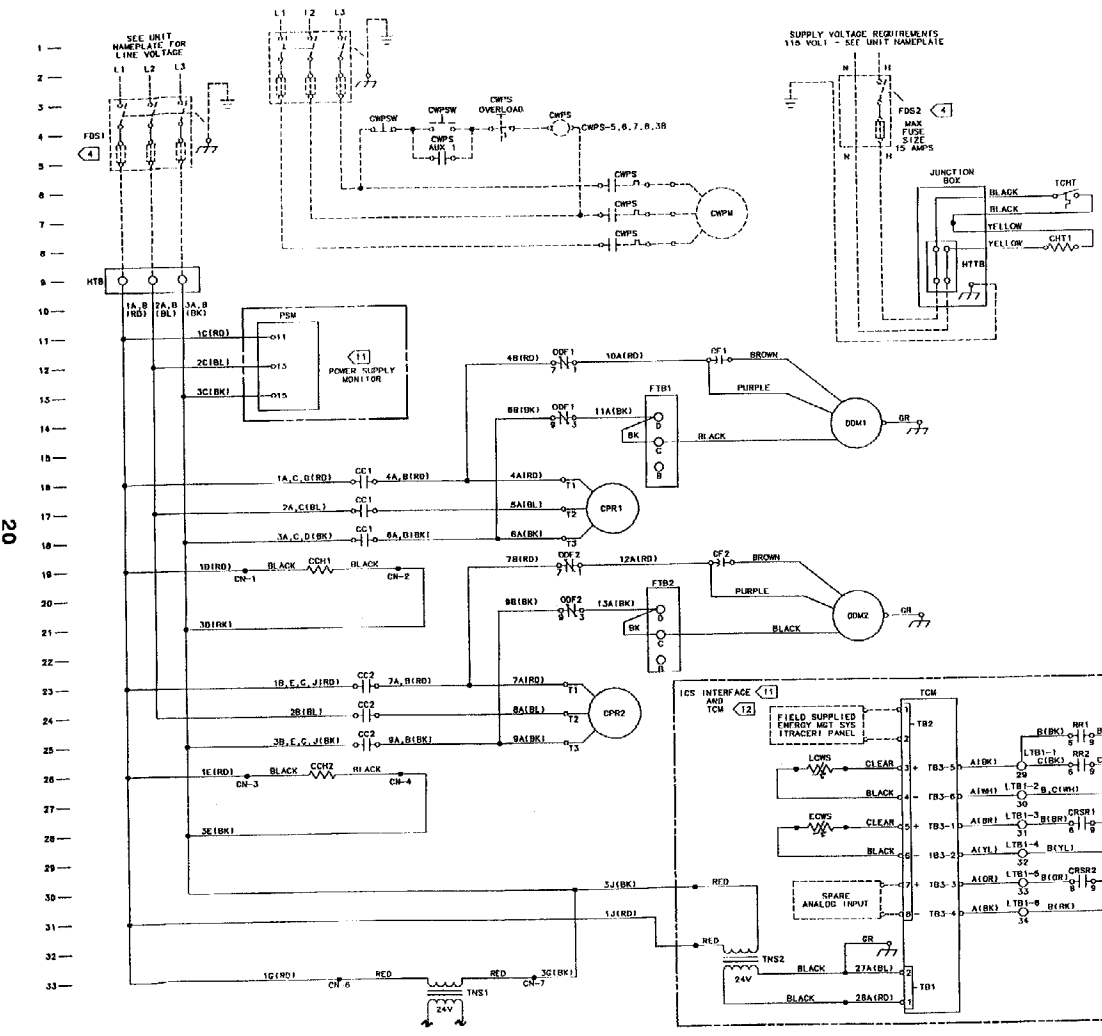

DEVICE DESIGNATION	DESCRIPTION	LINE NUMBER
ASCT1,ASCT2	ANTI-SHORT CYCLE TIMER	40,50
CC1,CC2	COMPRESSOR CONTACTOR	41,51
COHA	DRAINAGE HEATER	19
COHB	DRAINAGE HEATER	26
CF1,CF2	OUTDOOR FAN CAPACITOR	12,18
CHT1,CHT2	CHILLER HEAT TAPE	8,9
CN	CONNECTOR OR WIRE NUT	
CPR1,CPR2	COMPRESSOR	17,23
CHM1,CHM2	COMPRESSOR RUN HOUR METER	44,54
CRS1,CRS2	COMPRESSOR RUN STATUS RELAY	42,52
CSC1,CSC2	COMPRESSOR START COUNTER	45,55
CWR	CHILD WIND FLOW WATER/LOOK RELAY	38
CWP	CHILLER WATER PUMP MOTOR	7
CWPS	CHILLER WATER PUMP STARTER	4
CWPSW	CHILLER WATER PUMP SWITCH	4
DBC	RELAY BETWEEN COMPRESSORS	4
ECWS	ENTERING CHILLED WATER SENSOR	5,9
FDS1,FDS2	FUSED DISCONNECT SWITCH	4,4
FS	FLOW SWITCH	38
FTB1,FTB2	FAN TERMINAL BLOCK	15,20
FU	CONTROL CIRCUIT FUSE	11
HDS	HOT GAS BYPASS SOLENOID	48
HBT	HOT GAS BYPASS SWITCH	48
HPD1,HPD2	HIGH PRESSURE CUTOFF	42,52
HTB	HIGH VOLTAGE TERMINAL BLOCK	9
HTTB	HEAT TAPE TERMINAL BOARD	8,8
LAST1,LAST2	LOW AMBIENT START TIMER	47,57
LWS	LEAVING CHILLED WATER SENSOR	28
LPC1,LPC2	LOW PRESSURE CUTOFF	42,52
LTB1,LTB2	LOW VOLTAGE TERMINAL BLOCK	38
LTC	LOW TEMPERATURE CUTOFF	38
ODM1,ODM2	OUTDOOR FAN MOTOR	14,21
ODF1,ODF2	OUTDOOR FAN RELAY	47,57
PSM	POWER SUPPLY MONITOR	11
RH1,RH2	RESET RELAY	41,51
TCH	CHILLER HEAT TAPE THERMOSTAT	6
TCM	TCM MODULE	24,38,52
TNS1	CONTROL POWER TRANSFORMER	33
TNS2	TCM POWER SPLY TRANSFORMER	33
WT	WATER TEMP T-STAT (2-STEP)	44

**WARNING**  
 DISCONNECT ELECTRIC POWER SUPPLY BEFORE SERVICING TO PREVENT INJURY OR DEATH DUE TO ELECTRICAL SHOCK.

**AVERTISSEMENT**  
 DEBRANCHER DU CIRCUIT D'ALIMENTATION ELECTRIQUE AVANT L'ENTRETIEN POUR EVITER BLESSURE OU MORT PAR ELECTROCUTION.

**CAUTION**  
 USE COPPER CONDUCTORS ONLY TO PREVENT EQUIPMENT DAMAGE. UNIT TERMINALS ARE NOT DESIGNED TO ACCEPT ANY OTHER WIRING.

**ATTENTION**  
 UTILISER SEULEMENT DES CONDUCTEURS EN CUIVRE POUR EVITER D'ENDOMMAGER L'EQUIPEMENT. LES BORNES NE SONT PAS PREVUES POUR AUTRES TYPES DE FILS CONDUCTEURS.

(Continued on next page)

34  
35  
36  
37  
38  
39  
40  
41  
42  
43  
44  
45  
46  
47  
48  
49  
50  
51  
52  
53  
54  
55  
56  
57  
58  
59  
60

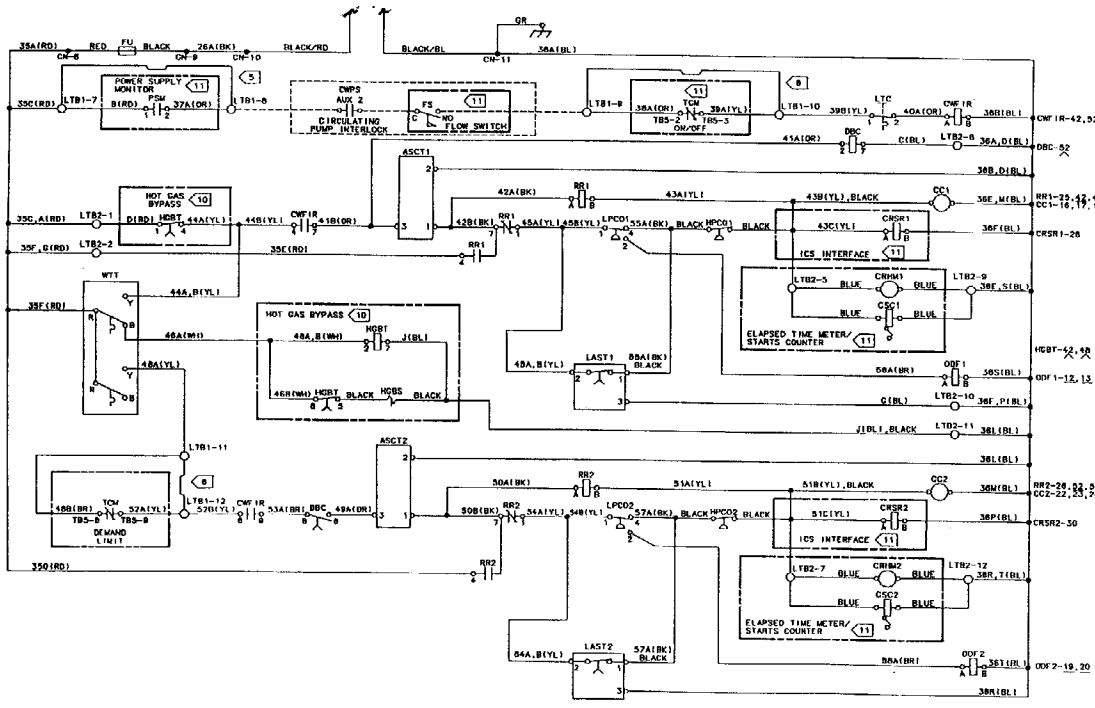

- NOTES:
- UNLESS OTHERWISE NOTED, ALL SWITCHES ARE SHOWN AT 25°C (77°F) AT ATMOSPHERIC PRESSURE. AT 50% RELATIVE HUMIDITY, WITH ALL UTILITIES TURNED OFF AND AFTER A NORMAL SHUTDOWN HAS OCCURRED.
  - DASHED LINES INDICATE RECOMMENDED FIELD WIRING BY OTHERS. DASHED LINE ENCLOSURES AND/OR DASHED DEVICE OUTLINES INDICATE COMPONENTS PROVIDED BY THE FIELD. PHANTOM LINE ENCLOSURES INDICATE ALTERNATE CONSTRUCTION CIRCUITRY OR AVAILABLE FIELD INSTALLED ACCESSORIES. SOLID LINE INDICATES WIRING BY TRANE CO.
  - NUMBERS ALONG THE RIGHT SIDE OF THE SCHEMATIC DESIGNATE THE LOCATION OF CONTACTS BY LINE NUMBER. AN UNDERLINED NUMBER INDICATES A NORMALLY CLOSED CONTACT. AN OPEN ARROWHEAD BELOW THE LINE NUMBER POINTING UPWARD INDICATES A TIMED CONTACT WHICH BEGINS TIMING WHEN ENERGIZED.
  - FOR CANADIAN INSTALLATION (CSA) ONLY. LOCAL INSPECTION AUTHORITIES MAY REQUIRE SINGLE POWER SOURCE DISCONNECTING MEANS.
  - WHEN POWER SUPPLY MONITOR IS INSTALLED, REMOVE JUMPER BETWEEN LT81-7 AND LT81-9.
  - WHEN ICS INTERFACE ACCESSORY IS INSTALLED, REMOVE JUMPER BETWEEN LT81-9 & LT81-11 & 12.
  - ALL THREE PHASE MOTORS SUPPLIED WITH THE UNIT ARE PROTECTED UNDER PRIMARY SINGLE PHASE FAILURE CONDITIONS.
  - LOW VOLTAGE WIRING MUST BE 18 AMP MINIMUM.
  - ACCESSORIES ARE NOT AVAILABLE FOR 350-415V/50 HZ/3Ø - (WHERE NOTED).
  - ALTERNATE CONSTRUCTION, FACTORY INSTALLED ONLY.
  - ACCESSORY: FIELD INSTALLED ONLY.
  - TCM IS NOT INCLUDED IN THE ICS INTERFACE ACCESSORY.

WIRE COLOR DESIGNATION			
ABBR	COLOR	ABBR	COLOR
BK	BLACK	OR	ORANGE
BL	BLUE	RD	RED
BR	BROWN	WH	WHITE
GR	GREEN	YL	YELLOW

**Figure 10**  
**CGA180B4 (460V/60/3) and**  
**CGA180BW (575V/60/3) Connection Diagram**

(Continued on next page)

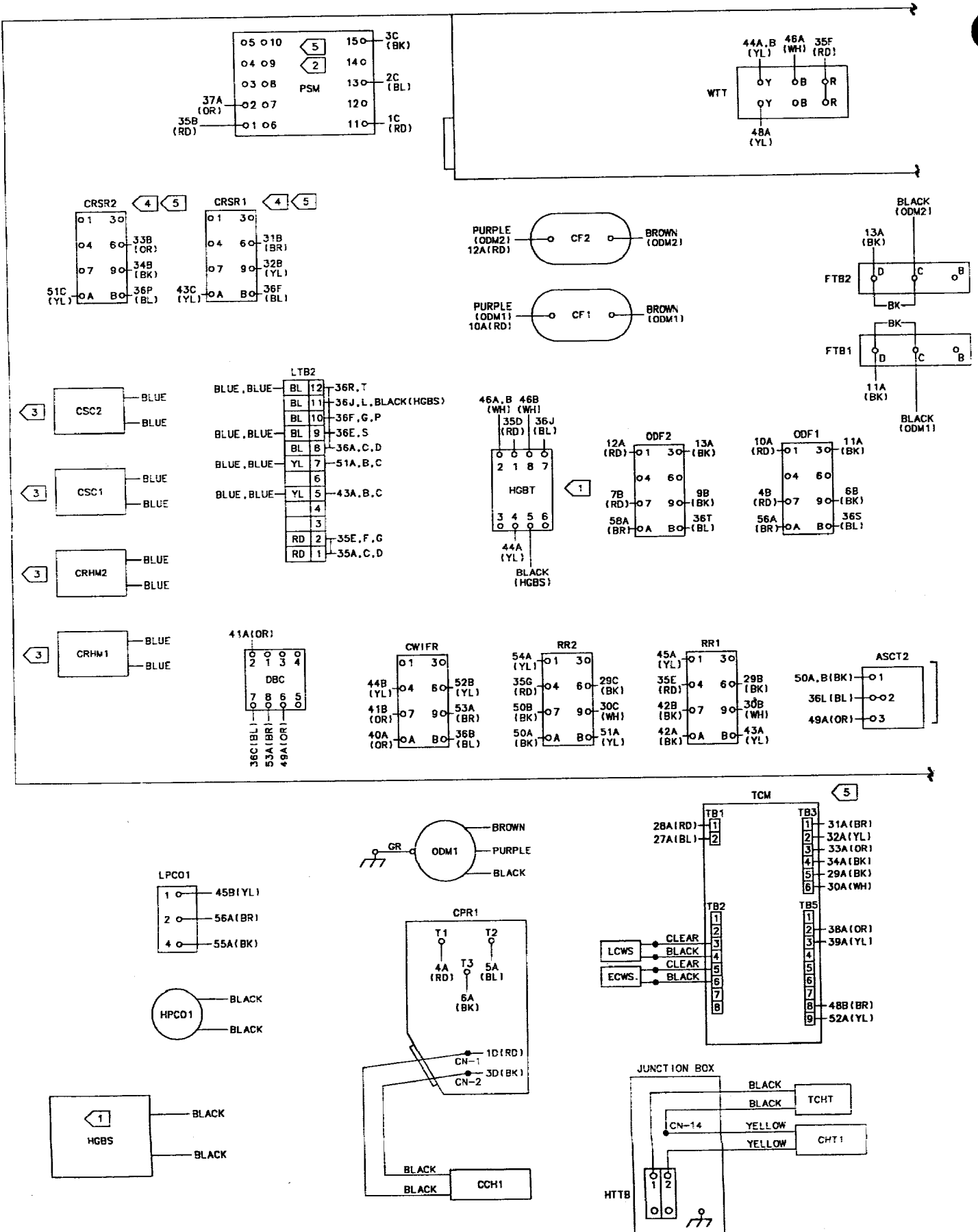

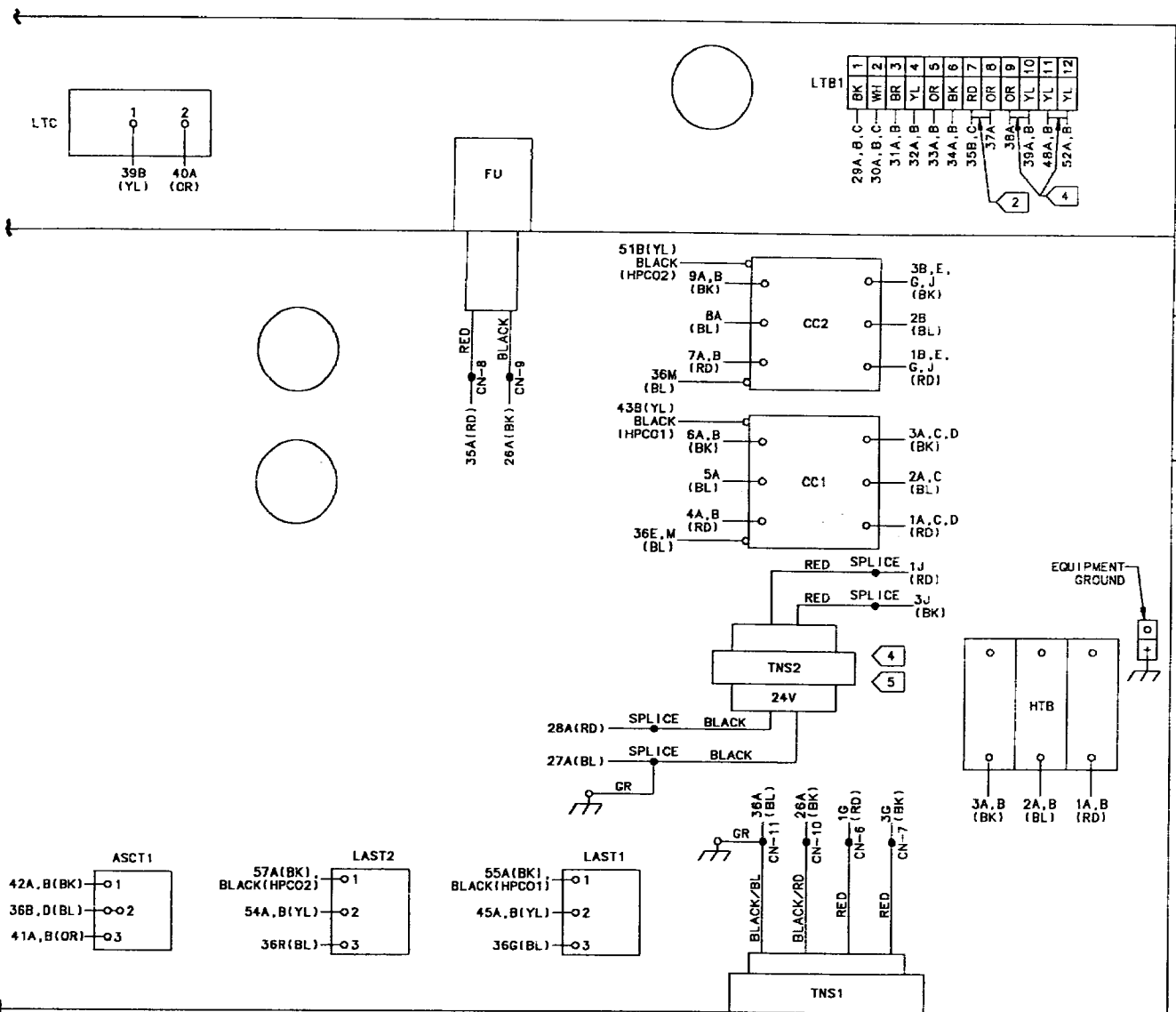

NOTES:

- 1 HOT GAS BYPASS ALTERNATE CONSTRUCTION INCLUDES HGBT, HGBS AND ASSOCIATED WIRING. (FACTORY INSTALLED ONLY).
- 2 FIELD INSTALLED POWER SUPPLY MONITOR ACCESSORY. REMOVE JUMPER BETWEEN LTB1-7 AND LTB1-8 WHEN INSTALLED.
- 3 FIELD INSTALLED ELAPSED TIME METER/ STARTS COUNTER ACCESSORY.
- 4 FIELD INSTALLED INTEGRATED COMFORT SYSTEM INTERFACE ACCESSORY. REMOVE JUMPERS BETWEEN LTB1-9 & LTB1-10 AND LTB1-11 & LTB1-12 WHEN INSTALLED.
- 5 THIS ACCESSORY NOT AVAILABLE FOR 380-415V/50 HZ/2 PH UNIT APPLICATION.

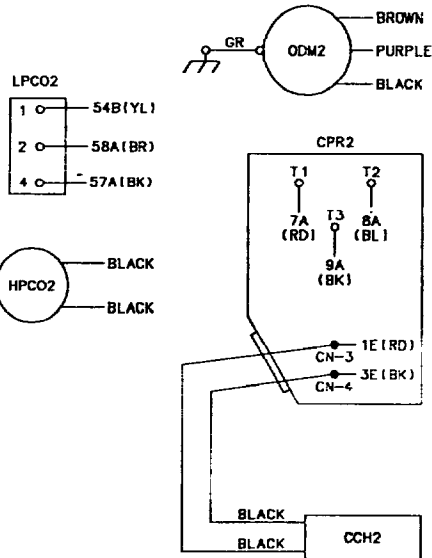

<p><b>⚠ WARNING</b> DISCONNECT ELECTRIC POWER SUPPLY BEFORE SERVICING TO PREVENT INJURY OR DEATH DUE TO ELECTRICAL SHOCK.</p> <p><b>AVERTISSEMENT</b> DEBRANCHER DU CIRCUIT D'ALIMENTATION ELECTRIQUE AVANT L'ENTRETIEN POUR EVITER BLESSURE OU MORT PAR ELECTROCUTION.</p>	<p><b>⚠ CAUTION</b> USE COPPER CONDUCTORS ONLY TO PREVENT EQUIPMENT DAMAGE. UNIT TERMINALS ARE NOT DESIGNED TO ACCEPT ANY OTHER WIRING.</p> <p><b>ATTENTION</b> UTILISER SEULEMENT DES CONDUCTEURS EN CUIVRE POUR EVITER D'ENDOMMAGER L'EQUIPEMENT. LES BORNES NE SONT PAS PREVUES POUR AUTRES TYPES DE FILS CONDUCTEURS.</p>
-------------------------------------------------------------------------------------------------------------------------------------------------------------------------------------------------------------------------------------------------------------------------------------	---------------------------------------------------------------------------------------------------------------------------------------------------------------------------------------------------------------------------------------------------------------------------------------------------------------------------------------

---

For further information on this product or other Trane products, refer to the "Trane Service Literature Catalog", ordering number IDX-IOM-1. This catalog contains listings and prices for all service literature sold by Trane. The catalog may be ordered by sending a \$35.00 check to: The Trane Company, Service Literature Sales, 3600 Pammel Creek Road, La Crosse WI 54601

RSS/PM

P.I. (C)