



Instruction Manual

V² Series

Centrifugal Pump



Read and understand this manual prior to operating or servicing this product.





INSTRUCTION and PARTS MANUAL

"V²" Series Centrifugal Pump

Model Number _____

Serial Number _____

General Assembly Number _____

Shaft Seal Type

- _____ Type 1 Rotating Carbon vs. 316 SS Back Plate
- _____ Type 2 Rotating Carbon vs. 316 SS Replaceable Insert in Back Plate
- _____ Type 3 John Crane, Rotating Carbon vs. 316 SS Replaceable Insert in Back Plate
- _____ Type 4 Water Flush John Crane Double Seal .
- _____ Type 5 Water Flush John Crane & APV Crepaco Double Seal

Optional Seal Feature

- _____ Teflon in place of rotating Carbon
- _____ Siliconized Carbon in place of rotating Carbon
- _____ Siliconized Carbon in place of 316 SS insert
- _____ Cascade Water Flush

Shaft Seal Gasket Material

- _____ Nitrile (Std.)
- _____ EPDM
- _____ Viton
- _____ Other (Please specify)

Casing O-ring Material

- _____ Nitrile (Std.)
- _____ EPDM
- _____ Viton
- _____ Other (Please specify)

Impeller O-ring Material

- _____ Nitrile (Std.)
- _____ EPDM
- _____ Viton
- _____ Other (Please specify)

Frame Size

04WP475770
(rev. 10/08/96 KAS)

Spares & Service Parts

1-888-APV-4321 Phone 1-888-APV-5329 Fax

APV CREPACO Instruction and Parts Manual

"V²" Sanitary Centrifugal Pump
Models 4V² 6V² 6VS² 8V² 8VS²

"V²" Industrial Centrifugal Pump
Models 14V² 16V² 16VS² 18V² 18VS²

Keep this Instruction and Parts manual in a safe place for future reference.

When requesting information about your pump, always state serial number.

Additional copies may be ordered through your local APV Crepaco Sales Representative.

APV, An SPX Brand

APV, An SPX Brand
611 Sugar Creek Road
Delavan, WI 53115
Phone: (888) 278-4321

APV Offices

611 Sugar Creek Road
Delavan, WI 53115
Phone: (888) 278-4321

1200 West Ash Street
Goldsboro, NC 27530
Phone: (919) 735-4570
Fax: (919) 581-1167

105 CrossPoint Parkway
Getzville, NY 14068
Phone: (800) 207-2708
Fax: (716) 692-1715

APV, An SPX Brand

APV, An SPX Brand
611 Sugar Creek Road
Delavan, WI 53115
Phone: (888) 278-4321

CANADA

3280 Langstaff Road
Concord, Ontario L4K 4Z8
Phone: (800) 263-3958
Fax: (905) 760-1865

INTERNATIONAL

Gotanda Chuo Building 3F
2-3-5 Higashi Gotanda, Shinagawa-ku
Tokyo 141-0022
Japan
Phone: (+81) 3 5793 5611
Fax: (+81) 35793 5615

Calle Amargura No. 60
Colonia Lomas de la Herradura,
Huixquilucan
Estados de Mexico 52760
Mexico
Phone: +525 555 263 0100
Fax: +525 555 557 2620

SOUTH AMERICA

Rua Joa Daprat 231
Sao Bernardo do Campo, SP 09600-010
Brazil
Phone: (+55) 11 21APVAPV (21 278 278)
Fax: (+55) 11 21APV260 (21 278 260)

Ricardo Lyon 222 Of. 503
Providencia, Santiago
Chile
Phone: (+56) 2 373 9887
Fax: (+56) 2 373 9886

Table of Contents

Introduction	1	Pre-Start-Up Procedures	22
APV Offices	2	First Cleaning	22
Standard Warranty	3	Drive	22
A Word About APV Crepaco		Flush Piping and Pump System	22
Service Parts	4	Check Impeller Diameter	
Safety Information	5	vs Motor Horsepower	23
Definitions	5	Impeller Trimming	24
Safety Decal Location	6	Machining Recommendations	
Safety Decals	7	for Impeller Trimming	25
Electrical Hazard	7	Impeller Balancing	26
Rotating Parts Hazard	8	Cleaning and Sanitizing	27
Cleaning/Sanitizing Chemical Hazard	8	Definitions	28
High Temperature Hazard	9	Methods for Cleaning and Sanitizing	28
High Pressure Hazard	9	Shaft Seals	30
Leaking Fluid Hazard	9	Type 1 Seal	31
Important Cautions	10	Type 2 Seal	31
Cavitation	10	Type 3 Seal	31
Corrosion Pitting	10	Type 4 Seal	31
Motor Overload	10	Type 5 Seal	31
Excessive Pressure	11	Theory of Operation	32
Impeller Shaft Location	11	Operation	34
General Information	12	Pump Operation	34
General Description	12	Maintenance	35
Models	12	Component Identification	35
Materials of Construction	12	Casing and Impeller	36
Serial Number	12	Backplate	37
Maximum Performance	13	Product Seals - Type 1, 2, and 5 Shaft Seals	38
General Specifications	13	John Crane™ Mechanical Seals	
Components and Services		Type 3 and 4	39
Furnished by Customer	14	Impeller Shaft	41
Receiving and Inspection	14	Routine Wear Checks	43
Installation	15	Lubrication	44
Selecting the Pump Location	15	Problem Solving Guide	45
Electrical Connections	15		
Piping Connections	16		
Welding Ferrules to Casing	18		
Pump Mounting Methods	18		
Mounting the Pump to the Motor	18		
Leveling Close Coupled Mounted Units	19		
Coupling Alignment	19		
Coupling Misalignment	19		
Water Flush Seals	21		

Table of Contents

Parts Manual	47
Models 4V², 6V², 6VS², 8V², 8VS²	
Standard	48
Options	50
Type 1 Seal	56
Type 2 Seal	58
Type 3 Seal	60
Type 4 Seal	62
Type 5 Seal	64
Models 14V², 16V², 16VS², 18V², 18VS²	
Standard	68
Options	70
Type 1 Seal	76
Type 2 Seal	78
Type 3 Seal	80
Type 4 Seal	82
Type 5 Seal	84
Recommended Inventory	87

Introduction

Congratulations, you are the owner of a quality built item of APV Crepaco. This machine was manufactured by the skilled craftsmen of a company which has served the needs of the dairy, food, and process industries for more than 100 years.

The purpose of this manual is to provide instructions for the safe installation, operation, and maintenance of your APV Crepaco equipment.

Read and understand the entire manual before removing from the crate and installing the equipment.

APV Crepaco is committed to provide quality equipment and customer satisfaction. We have a unique network of sales and service support throughout the world, which are listed on the following pages. Note the office nearest you. Should you have any questions concerning any information contained in this manual, contact the nearest office or our Delavan, Wisconsin office for assistance.

Receiving and Inspection

1. APV Crepaco equipment is run tested or inspected prior to shipment. When leaving the factory, it is well crated for normal transportation procedures. APV Crepaco cannot, however, guarantee safe arrival. Therefore, upon receipt of this equipment, check the received items against the packing list for damage or missing parts. Check the packing material thoroughly for small parts.
2. Visually inspect for damage or loss. Damage or loss should be reported immediately to the delivery carrier while present. Following the immediate notification of the lost or damaged parts, a detailed description including quantity, description of the loss or damage, and a cash value should be claimed against the carrier with respect to the guidelines set forth by the responsible carrier's policies. APV Crepaco's responsibility terminates F.O.B. point of manufacture unless otherwise specified per the General Terms and Conditions of Sale as published by APV Crepaco and amended from time to time. Contact APV Crepaco Order Services if shipping information is required for handling claims.
3. In the case of damage or loss to the equipment, APV Crepaco may perform three major functions:
 - a. **Manufacturer Function** - APV Crepaco manufactures quality equipment and stands behind the APV Crepaco Standard Warranty. Refer to the Standard Warranty.
 - b. **Assessor Function** - APV Crepaco offers assessment services for filing claims. The APV Crepaco assessor will accurately determine the extent of the damage (or loss), and cost of repairs to the equipment. Reimbursement for this service will be agreed upon prior to the assessment.
 - c. **Repair House Function** - APV Crepaco offers services for repairing the damage(s) or replacement of loss(es) to the equipment. APV Crepaco has the option to alter the Standard Warranty on refurbished or replacement parts. The cost of this service will be dependent upon the assessment that is made.

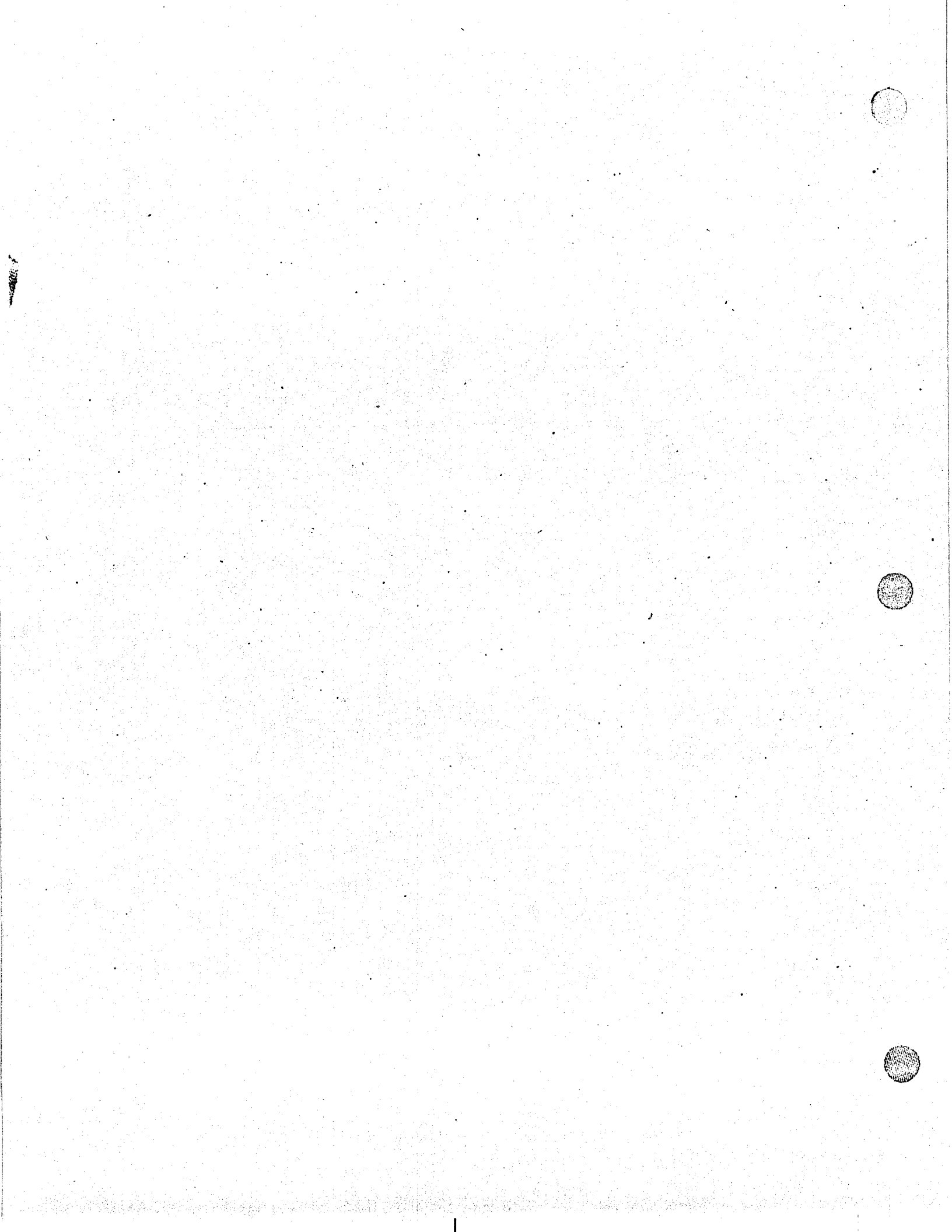

STANDARD WARRANTY

Obligations of Seller

During the warranty period, Seller shall repair, or at Seller's option, replace parts determined by Seller to be defective in material or workmanship. The warranty period is one (1) year from the date of delivery to Buyer F.O.B. point of manufacture. The foregoing shall be the sole obligation of Seller under this warranty with respect to the equipment and other property included in this Agreement. With respect to equipment, materials, parts and accessories manufactured by others, Seller's sole obligation shall be to use reasonable efforts to obtain for Buyer the full benefit of the manufacturers' warranties.

Warranty Exclusions

Repair or replacement of parts required because of misuse, improper care or storage, negligence, alteration, accident, use of incompatible supplies or lack of specified maintenance are excluded from Seller's warranty obligations.

DISCLAIMER OF WARRANTIES

THE FOREGOING WARRANTY EXPRESSIONS ARE IN LIEU OF ALL OTHER WARRANTIES, EXPRESSED OR IMPLIED, INCLUDING IMPLIED WARRANTIES OF MERCHANTABILITY AND FITNESS FOR A PARTICULAR PURPOSE, AND EXISTENCE OF ANY SUCH OTHER WARRANTY IS HEREBY DENIED.

Limitation of Liability and Remedies

The liability of Seller for breach of any warranty obligation hereunder is limited to:

1. The repair or replacement of the equipment on which the liability is based; or,
2. At Seller's option, the refund to Buyer of the amount paid by Buyer to Seller for said equipment.

All other liability of Seller with respect to this Agreement, or from the manufacture, installation, maintenance, repair or use of any equipment covered by or furnished under this Agreement, whether in contract or in tort, or otherwise, is limited to the amount paid by Buyer to Seller pursuant to the terms hereon: SELLER SHALL NOT BE LIABLE FOR INCIDENTAL OR CONSEQUENTIAL DAMAGES OF ANY KIND WHATSOEVER. THE REMEDIES SET FORTH HEREIN ARE EXCLUSIVE.

Breach

Any breach by Seller with respect to any item or unit of equipment shall be deemed a breach with respect to that item or unit only.

Infringement

Seller will not be liable for the infringement of any patent by the Buyer's use of any equipment or materials delivered hereunder.

POLICY REGARDING AVAILABILITY OF SERVICE PARTS

APV Crepaco will attempt to remain in a position to supply replaceable service parts during the normal life of any item of APV Crepaco equipment. This will be contingent upon availability of tools, material, and facilities of our own as well as of our suppliers.

After expiration of this period, supply of service parts will be limited to available stock of completed parts. If unable to supply the service part, drawings will be furnished when available to permit local manufacturing, if desired.

APV Crepaco reserves the right to improve, change or modify the construction of its equipment or any parts thereof without incurring any obligation to provide like changes to equipment previously sold.

A Word About APV Crepaco Service Parts

We want to raise your awareness to the problem associated with purchase of parts not manufactured to the high quality specifications of APV Crepaco, INC.

In addition to our high quality, APV Crepaco parts are manufactured to meet regulatory agency authorizations, approvals and certification (3-A Sanitary Standards, USDA, ASME, BISSC and OSHA). Where applicable, materials used in construction of APV parts conform to FDA regulations.

WARNING

PARTS NOT MANUFACTURED TO OUR SPECIFICATIONS MAY CAUSE DAMAGES TO YOUR APV CREPACO EQUIPMENT AND VOID ALL WARRANTIES. USE OF PARTS THAT DO NOT MEET APV CREPACO, INC. SPECIFICATIONS MAY CAUSE PROPERTY DAMAGES AND SERIOUS BODILY INJURY.

Types of equipment include, but are not limited to, rotary pumps, centrifugal pumps, homogenizers, ice cream freezers, scrape surface heat exchangers, plate heat exchangers, ingredient feeders, process tank and contact plate freezers.

We bring this potentially serious problem to your attention in order to safeguard your best interest and those of your employees.

If you have any questions, please feel free to call 1-800-358-4100 or your local APV Crepaco Regional Sales Office.

Safety Information

Definitions

DANGER

An immediate hazard with a possibility of severe personal injury or death if instructions, including recommended precautions, are not followed.

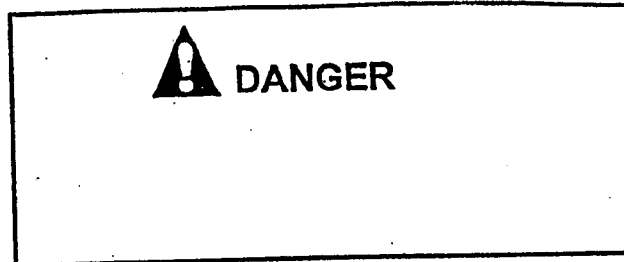

WARNING

Hazards or unsafe practices which could result in severe personal injury or death if instructions, including recommended precautions, are not followed.

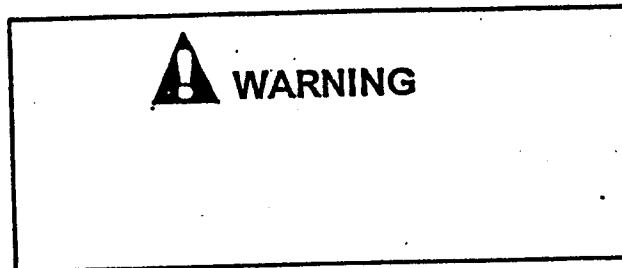

CAUTION

Possible hazards or unsafe practices which could result in minor injury or damage to product or property if instructions, including recommended precautions, are not followed.

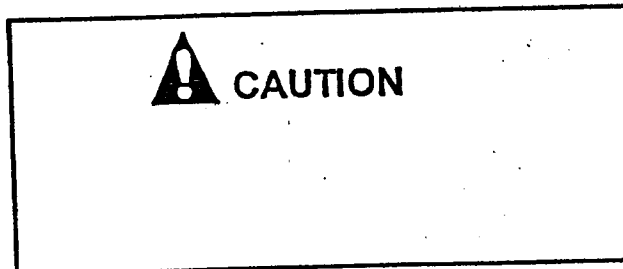

Lock Out

A positive means of securing the main electrical disconnect in the Off position, where only the person involved in the maintenance procedure has possession of the key.

Safety Information

The following information supplements the preceding **GENERAL SAFETY INSTRUCTIONS** and provides specific safety information on hazardous conditions which are inherent in the pump.

Safe installation, operation, and maintenance requires proper training of all personnel and their supervisors.

Our objective in providing instructions and warnings is to identify each area of potential hazards and its level of severity and to guide each worker for safe operation, service, and maintenance procedures.

APV Crepaco equipment is designed to provide minimum operator access to hazardous areas while providing adequate access for service by trained personnel.

Hazardous areas are provided with guards. Various types of fasteners may be used for the guards depending on how frequently routine access is required. Regardless of the type of fastener used, the existence of a guard should alert personnel to the presence of a hazard. Never operate or test run the equipment with a guard removed, unless under the supervision of properly trained and authorized personnel. Then use extreme caution to avoid the hazard.

Safety Decal Location

The illustration below shows the location of the safety information decals attached to the pump. If any decal is removed or becomes unreadable, replace it immediately with a new decal.

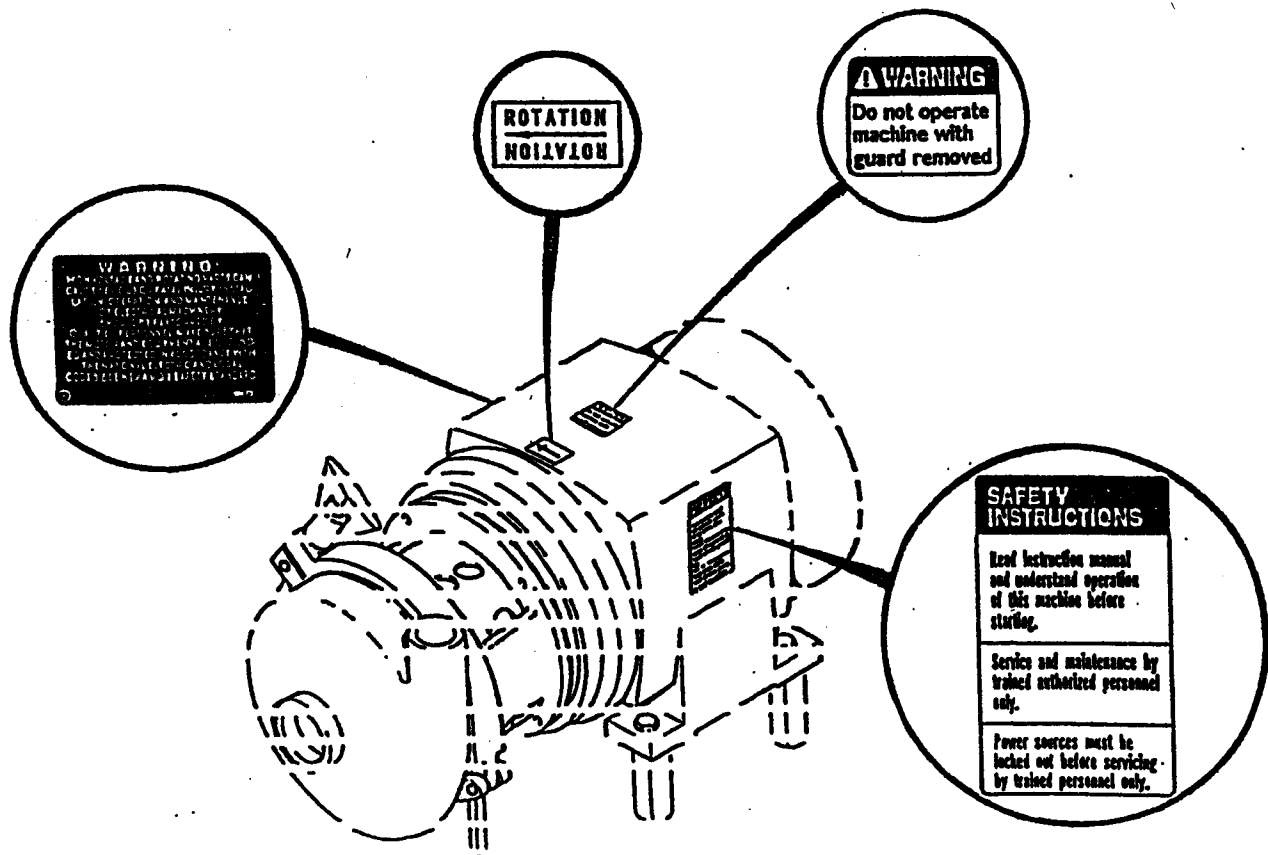

Typical Safety Decal Location

Safety Information

Safety Decals

The wording of the safety decals is shown below. If any decal is removed or becomes unreadable, replace it immediately with a new decal.

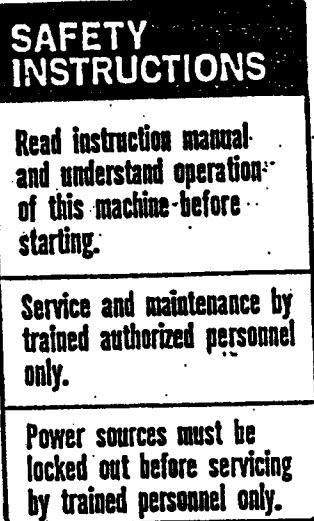

681-P-431690

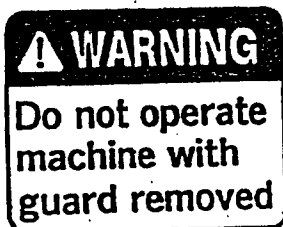

681-P-431689

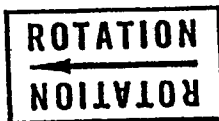

681-P-288335

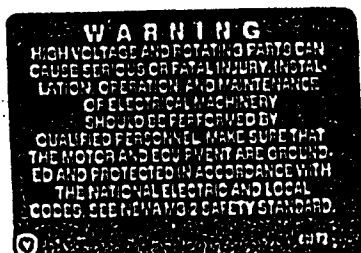

Safety Decals



DANGER

Electrical Hazard

A pump is normally powered by an electric motor. This creates a hazard of electrical shock which could cause severe injury or even loss of life.

To minimize the risk of this hazard:

1. All electric/electronic installation must comply with all applicable codes and standards including those established by the Occupational Safety and Health Administration (OSHA).
2. All electric/electronic installation, maintenance, and service must be performed by trained and authorized electricians only.
3. Install a main power disconnect On-Off switch that can be locked in the power Off position and have the key removed. This will allow maintenance or service to be performed with no possibility of the power being accidentally turned on.
4. Do Not perform any maintenance or service unless the main and control power sources have been turned off and Locked Out using a locking device for which only the person performing the maintenance has the key.
5. Thoroughly read the motor manufacturer's instructions before making installation.
6. Install an emergency shutoff switch within easy reach of the operator.
7. Make the installation suitable for a wet environment, including:
 - a. Protection from flooding. Do not install in an area which could fill with water to a level which would contact the motor.
 - b. Protection of all electric connections within a sealed junction box.
 - c. Proper grounding of the motor.

Safety Information



Rotating Parts Hazard

The pump contains close fitting parts which rotate during operation.

Routine cleaning and maintenance procedures require pump disassembly. Should the pump start unexpectedly while disassembled, severe injury could result.



ALWAYS turn off the electrical power supply and Lock Out, using a locking device for which only the person doing the work has the key, before performing service or maintenance.

To minimize the risk of this hazard: ..

1. Do Not assemble or disassemble the pump—
2. Do Not remove the guard from the adapter—
3. Do Not perform any maintenance or service on the motor or pump—
---unless the power source has been turned off and Locked Out, where only the person involved in the maintenance procedure has possession of the key.
4. Only trained and authorized personnel should perform maintenance or service work on the pump.
5. Install an emergency shutoff switch within easy reach of the operator.



Cleaning/Sanitizing Chemical Hazard

Cleaning and sanitizing a pump for use with food products may require the use of chemical solutions. Many of the commonly used chemical solutions are potentially harmful if contacted. The hazard is especially severe for eyes, skin, or inhalation. All personnel working with such solutions must be thoroughly trained in their safe handling and disposal following use as required by the OSHA.

Clean-In-Place (CIP) cleaning and sanitizing:

1. Refer to the Cleaning and Sanitizing section.
2. Make sure all line connections in the cleaning circuit are connected and tightened before starting.
3. Never disconnect any lines or fittings or disassemble the pump until it is known that the CIP cleaning sequence is completed and no chemical solutions or high temperature fluids are present.

Manual cleaning methods:

1. Refer to the Cleaning and Sanitizing section.
2. Turn the power source off and Lock Out, using a locking device for which only the person performing the maintenance procedure has the key, before doing any disassembly of the pump.
3. Equip all personnel using cleaning/sanitizing solutions with protective clothing, including eye protection.
4. Thoroughly train all personnel using cleaning/sanitizing solutions in their safe handling and disposal after use.
5. Never use toxic and/or flammable solvent for cleaning.

Safety Information



WARNING

High Temperature Hazard

Some pump applications may require processing of high temperature fluids and/or the use of high temperature cleaning/sanitizing solutions. Pumping high temperature fluids creates a hazard of burns from contact with the equipment or with leaking fluid.

To minimize the risk of this hazard:

1. All installation, maintenance, and service of piping, valves, and other controls must be performed by trained and authorized fitters only. This applies to process piping and cleaning/sanitizing piping.
 2. The installation of fittings must comply with all applicable codes and standards including those established by OSHA.
- All high temperature lines must be labeled, leak free, and insulated or otherwise protected from direct contact.
4. Never disconnect any lines or fittings or disassemble the pump until the line is not under pressure and the fluid inside is not hot or harmful.
 5. Operating personnel must be authorized and trained.



WARNING

High Pressure Hazard

Products processed by the pump are under pressure, which the possibility of a leak could occur. This creates a hazard to anyone in the area. Leaking high pressure fluid can cause injury from actual contact or by startling personnel.

To minimize the risk of this hazard:

1. All installation, maintenance, and service of piping, valves and other controls must be performed by trained and authorized fitters only. This applies to process piping and cleaning/sanitizing piping.
2. All fitting installation must comply with all applicable codes and standards including those established by OSHA.
3. Never disconnect any lines or fittings or disassemble the pump until the system is not under pressure and the fluid inside is not hot or harmful.
4. Should a leak occur, find and correct the cause immediately.



WARNING

Leaking Fluid Hazard

Fluid leaks or spills can occur in any pumping system. This creates a hazard to anyone in the area due to slippery floor conditions or contact with possibly hazardous fluids.

To minimize the risk of this hazard:

1. Always clean up leaks and spills immediately.
2. Find and correct the cause of the leak immediately.

Important Cautions



CAUTION

Cavitation

Cavitation is liquid vaporizing, then collapsing back to a liquid inside the pump. Cavitation, characterized by a noisy "rattling" sound, is caused by operating with too low of fluid pressure at the pump inlet connection. Cavitation can create a risk of severe damage to pump components and reduces pump performance significantly.

To minimize this risk:

Install and operate the pump so that the net positive suction head (NPSH) available to the pump equals or exceeds the NPSH required. To increase NPSH available:

1. Decrease the temperature of the product being pumped.
2. Increase the height of the product supply level.
3. Decrease the suction line length and remove restrictions to product flow such as elbows, valves, etc.
4. Increase the suction line size (diameter).
5. Reduce the pump flow rate (throttle discharge).
6. Reduce the product viscosity.
7. Decrease the vacuum in the product supply vessel.



CAUTION

Corrosion Pitting

Stainless steel is subject to a risk of corrosion when improperly cleaned or sanitized.

To minimize this risk:

1. Never use steel wool or a wire brush to clean stainless steel surfaces. Iron particles will embed and cause corrosion pits. Use a nonmetallic brush or scrub pad for stubborn soil.
2. Never allow prolonged contact of sanitizing solutions or other corrosive cleaning chemicals with stainless steel. Only use sanitizers immediately prior to processing. Do not use sanitizers on exterior, non-product contact surfaces.



CAUTION

Motor Overload

Depending on the application and motor horsepower, the pump motor could overload if operated with a fully opened, unrestricted discharge.

To minimize this risk:

1. BEFORE operating the pump, review the performance curve and application giving consideration to motor horsepower versus expected discharge flow rate and pressure. If the pump is operated with less than expected discharge pressure, the flow rate will increase and the load on the motor will increase.
2. Install a throttling type valve in the discharge piping to allow control of the pump discharge flow rate during initial operation. The valve may be removed after the system is proven to supply adequate discharge pressure to prevent motor overload.

Important Cautions



CAUTION

Excessive Pressure

Excessive pressure is a condition within the pump which is the result of internal pressures exceeding the pressure rating for the pump.

Operating the pump at pressures exceeding the pressure rating for the pump will create a risk of severe damage to the pump.

To minimize this risk:

1. Before operating the pump, review the pump maximum discharge pressure rating and the system in which the pump will be operating.
2. If the system discharge pressure is unknown, install gauges and start with a reduced flow rate to make sure operation will be below the maximum discharge pressure rating.



CAUTION

Impeller Shaft Location

The location of the impeller shaft on the motor shaft is critical for correct pump operation and to obtain maximum operating efficiency.

Incorrect location of the impeller shaft may cause the impeller to contact the casing or the backplate during operation.

This contact could create a risk of severe damage to pump components.

To minimize this risk:

Refer to the Maintenance section for the procedures to correctly locate the impeller shaft whenever:

1. A new pump is installed onto a motor or pedestal.
2. The impeller shaft is loosened or removed from the motor or pedestal shaft.
3. A replacement casing or backplate is installed.

General Information

General Description

The "V²" Series Centrifugal Pump is designed for pumping low to medium viscosity liquids. The unit features a four-blade, fully-open, non-clog impeller that is the optimum design for sanitary service. The volute design provides high efficiency over a wide range of operating conditions.

The casing has controlled wall thickness and dimensional accuracy throughout. The backplate is machined from heavy stainless steel plate. The unique clamping assembly uses clamp rings with a self-locking internal angle that resists distortion and provides optimum sealing between the casing and backplate. The clamp rings are investment cast for greater strength than the stamped clamp rings common to other sanitary pumps.

A replaceable seat is provided in the backplate with optional seal types #2, 3, 4, and 5. This seat is reversible, providing a new wear surface without part replacement.

All "V²" models are provided with a guard around the rotating shaft. The guard fits inside the adapter.



WARNING

The adapter guard must be in place any time the pump is operated.

Models

Sanitary Models

Sanitary models 4V², 6V², 6VS², 8V², and 8VS² are designed and constructed to meet the requirements of the 3-A Sanitary Standards for cleanability of dairy processing equipment.

Meeting these standards requires, in part, that materials of construction in product contact areas be stainless steel or other materials approved for food contact. All product contact surfaces must be smooth, free draining, and accessible for cleaning. The mechanical product components must be easy to disassemble for cleaning and/or inspection for cleanliness.

The outer construction must prevent outside contaminants from draining or dripping into the product area.

Sanitary models are provided with mounting legs as standard.

Industrial Models

Industrial models, 14V², 16V², 16VS², 18V², and 18VS², are identical to the sanitary models in design, performance, and quality of construction with the exception of the internal and external surface finish on the product contact parts.

Parts for the sanitary and industrial models of the same basic size are interchangeable.

Mounting legs are optional on industrial pumps.

Materials of Construction

All metal product contact parts are type 316 stainless steel, except the impeller retaining pin which is 15-5 PH stainless steel. Standard gaskets and seal materials are food grade nitrile rubber or carbon. Alternate seal materials are available as noted in the Service Parts section.

All models are designed with corrosion resistant smooth surfaces and crevice free construction for easy cleaning. In addition, they are easy to disassemble for manual cleaning or for inspection.

Serial Number

A nameplate with a serial number is attached to the adapter of each pump. Use the serial number for reference whenever requesting information or service parts. The serial number is a letter followed by four numbers (for example, A-1234). Each pump has a unique serial number.

General Information

Maximum Performance

Maximum performance ratings are based on pumping water at 70 F (21 C). For specific applications contact your APV Crepaco sales representative.

Impeller Size

Listed data is for maximum impeller diameter. Alternate, trimmed impeller diameters are available for lower performance requirements.

Pump RPM

Performance is rated at 1750 rpm and 3500 rpm, the two most common motor speeds used. Alternate, lower speed operation is possible (for example, 1450 or 2900 rpm with 50 hz motors). For specific applications contact your APV Crepaco sales representative.

Pump Mounting

The pump attaches directly to the motor (close coupled). A C-face, foot-mounted, motor is required for attaching to the pump adapter. The pump and motor are supported by legs attached to the motor feet and to the pump adapter.

General Specifications

Pump Model	Connections		Impeller Max. Dia. in. (mm)	Maximum Performance						Range of Motor Frame Sizes
	Inlet Size in. (mm)	Outlet Size in. (mm)		1750 rpm			3500 rpm			
				Capacity gpm (cu. m/hr)	Head ft. (m)	Shut-off Head ft. (m)	Capacity gpm (cu. m/hr)	Head ft. (m)	Shut-off Head ft. (m)	
4V ² or 14V ²	1-1/2 (38)	1-1/2 (38)	3-13/16 (97)	77 (17.5)	7 (2.1)	18 (5.5)	130 (29.5)	28 (8.5)	62 (18.8)	56C through 145TC
	2 (51)	1-1/2 (38)								
6V ² or 16V ²	2 (51)	1-1/2 (38)	5-13/16 (148)	135 (31)	23 (7)	41 (12.5)	280 (63.5)	87 (26.3)	167 (50.9)	56C through 215TC
	2-1/2 (63)	1-1/2 (38)								
6VS ² or 16VS ²	3 (76)	2 (51)	5-13/16 (148)	260 (60)	18 (5.5)	41 (12.5)	520 (118)	60 (18.3)	167 (50.9)	145TC through 286TSC
8V ² or 18V ²	2 (51)	1-1/2 (38)	7-13/16 (200)	220 (50)	32 (9.7)	76 (23)	405 (92)	163 (49.4)	305 (92.4)	143TC through 284TSC
	3 (76)	2 (51)								
8VS ² or 18VS ²	3 (76)	2 (51)	7-13/16 (200)	330 (75)	37 (11.2)	76 (23)	515 (117)	187 (56.6)	305 (92.4)	145TC through 326TSC

General Information

Components and Services Furnished by Customer

Drive

The drive for the pump is to be supplied and installed by the purchaser unless otherwise specified at the time of purchase.

Electrical Service

Provide correctly sized electrical service to the motor including a motor starter, overload protection, and Lock Out capability.

If an alternate, non-electrical drive is furnished as an option, special instructions will be included.

Process Piping

Piping must be well supported near the pump and in line with connection fittings so that no strain is put on the fittings. The use of large diameter lines and wide sweep elbows is recommended to keep pressures to a minimum level.

The purchase and installation of all piping is the responsibility of the purchaser. This includes any valves, ingredients, and cleaning solutions which are routed to and from the pump.

Piping, valves, etc., may be purchased through the APV Crepaco sales offices serving you.

Seal Flush Media and Media Piping

If the seal requires flush media, the media supply and the purchase and installation of piping, fittings, and valves for the media are the responsibility of the purchaser.

Receiving and Inspection

1. APV Crepaco equipment is run tested or inspected prior to shipment. When leaving the factory, it is well crated for normal transportation procedures. APV Crepaco cannot, however, guarantee safe arrival. Therefore, upon receipt of this equipment, check the received items against the packing list for damage or missing parts. Check the packing material thoroughly for small parts.
2. Visually inspect for damage or loss. Damage or loss should be reported immediately to the delivery carrier while present. Following the immediate notification of the lost or damaged parts, a detailed description including quantity, description of the loss or damage, and a cash value should be claimed against the carrier with respect to the guidelines set forth by the responsible carrier's policies. APV Crepaco's responsibility terminates F.O.B. point of manufacture unless otherwise specified per the General Terms and Conditions of Sale as published by APV Crepaco and amended from time to time. Contact APV Crepaco Order Services if shipping information is required for handling claims.
3. In the case of damage or loss to the equipment, APV Crepaco may perform three major functions:
 - a. **Manufacturer Function** - APV Crepaco manufactures quality equipment and stands behind the APV Crepaco Standard Warranty. Refer to the Standard Warranty.
 - b. **Assessor Function** - APV Crepaco offers assessment services for filing claims. The APV Crepaco assessor will accurately determine the extent of the damage (or loss), and cost of repairs to the equipment. Reimbursement for this service will be agreed upon prior to the assessment.
 - c. **Repair House Function** - APV Crepaco offers services for repairing the damage(s) or replacement of loss(es) to the equipment. APV Crepaco has the option to alter the Standard Warranty on refurbished or replacement parts. The cost of this service will be dependent upon the assessment that is made.

Installation

Selecting the Pump Location

When installing the pump, consider these items before selecting a location.

1. Install the pump close to the product source to keep suction piping to a minimum.
2. Locate with consideration that the suction and discharge piping should be direct with minimum elbows and fittings to minimize head loss due to friction.
3. Locate so the pump and pump drives are accessible for inspection and service.
4. Locate so the pump is low in relation to product supply to provide maximum static suction head.
5. Locate so the motor is protected from flooding.
6. Locate near floor drains with a hose station nearby.
7. Locate so there is space available for lifting equipment if the pump components, or the complete pump, weigh more than 50 lbs. (22 kg).

Electrical Connections



DANGER

Incorrect electrical installation could cause an electric shock which could result in severe injury or even loss of life. All electrical/electronic installation must be performed by trained and authorized electricians only. All electrical/electronic installation must comply with all applicable codes and standards including those established by the Occupational Safety and Health Administration (OSHA).

1. Provide a main power disconnect On-Off switch that can be locked in the power Off position and have the key removed. This will allow service and maintenance to be performed with no possibility of the power being accidentally turned on.
2. Make sure installation is suitable for a wet environment.
3. Thoroughly read the motor manufacturer's instructions prior to installation.
4. Make sure the motor nameplate data matches the electrical supply.
5. Make sure all wiring, switches, starters, and overload protection are correctly sized.
6. Make sure the pump rotation is counterclockwise when viewing the pump from the suction connection side.

Installation

Piping Connections



CAUTION

Thoroughly clean all pipe lines to remove all dirt and foreign material before connecting them to the pump. Do not operate the pump for initial flushing of the system after installation. Foreign material may enter the pump and cause damage.

1. Support the suction and discharge piping. Use sturdy supports, near the pump and in line with connection fittings so that no strain is transmitted to the pump casing. If expansion joints are used in the piping, install a support between the expansion joint and the pump.
2. Align joints and use reliable fitting gaskets to prevent leaks.
3. Install suction piping to minimize suction friction loss. This will also maximize pump suction performance and reduce possibility of damaging cavitation. Keep the line short, with a minimum of elbows and other fittings. Use a pipe size equal to or larger than the suction connection on the pump.
4. If branching is necessary in the suction line, a "Y" fitting is preferable to a tee.

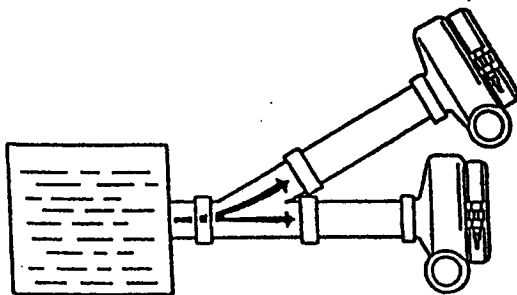

"Y" Pipe for Suction Line

5. Install a straight length of piping at least four diameters long at the suction and discharge connections before any elbows or other change-of-direction fittings.
6. Position the pump discharge so that when facing the pump the discharge is up, to the left or to points in between. With the discharge in these positions the pump casing is more likely to remain flooded. This minimizes the risk of damage to the pump caused by severe air slugging. When unavoidable air makes pump priming difficult, position the discharge 45 degrees to the left of vertical for best results.

Recommended
Discharge
Position

Best Position for Priming
With Air Present

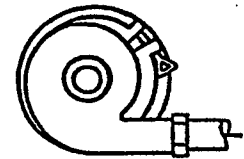
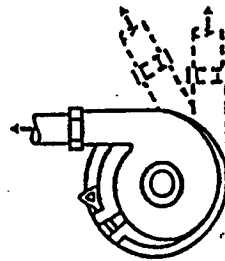

Recommended

NOT Recommended

Discharge Positions

7. Install a throttling type valve in the discharge piping (either permanently or temporarily until start-up is completed). Throttling discharge during initial start-up is recommended to guard against potential motor overload.

Throttling discharge during starting protects against "water hammer" which is most prevalent when using long pipe runs at high flow velocity.

Installation

Good Arrangements

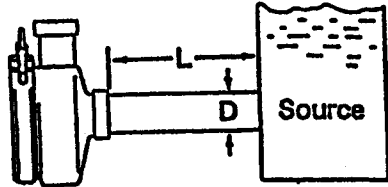

$10xD = L$

$10 \times 2 \text{ in.} = 20 \text{ in.}$

Ideal Piping Configuration

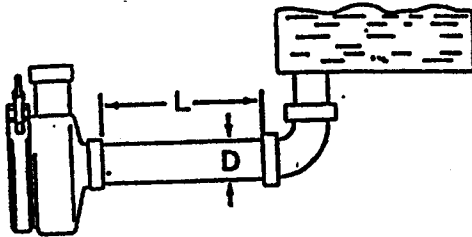

$10xD = L$

$10 \times 2 \text{ in.} = 20 \text{ in.}$

Minimum Elbows, Piping All in One Plane

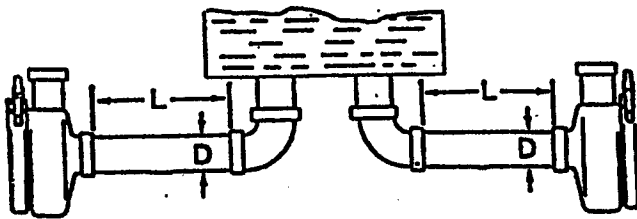

$10xD = L$

$10 \times 2 \text{ in.} = 20 \text{ in.}$

Two Pumps from a Common Source Preferred Configuration

Poor Arrangements

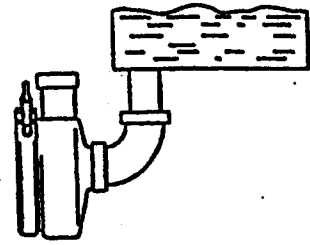

Elbow Connected Directly to Pump Section

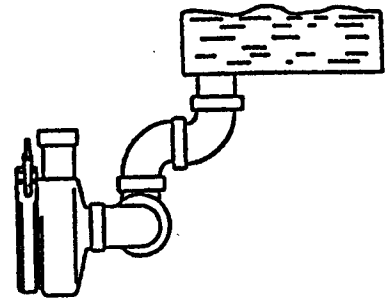

Too Many Elbows in Different Planes

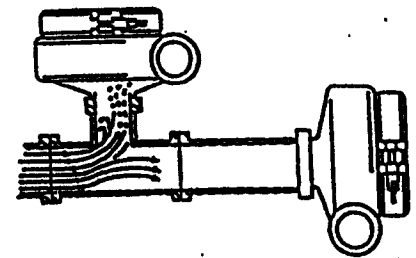

Pump Suction Too Close to Tee

Piping Arrangements

Installation

Welding Ferrules to Casing

Pumps supplied with butt weld type inlet and outlet connections require welding to the process piping or to casing connection ferrules. Use the TIG welding method and correct procedure to obtain a "sanitary" weld, free of pits, cracks, or crevices when processing food products.



CAUTION

Excessive heat during welding may distort the casing and change critical clearances within the pump. Use a heat sink and welding technique for minimum heating of the casing.

Pump Mounting Methods

Two methods may be used to mount the pump to the drive or motor, close coupled or pedestal. Each requires a different type of motor frame.

Close Coupled

1. The pump attaches directly to the motor. The pump and motor are supported by legs attached to the motor base and to the pump adapter.
2. The correct motor frame for close coupled pumps is a foot-mounted, C-face or D-face (metric) motor. C-face motors must meet NEMA dimensional standards.
3. The motor frame must be foot-mounted to support both the motor and the pump.
4. Sanitary design pumps are supplied with three legs. Two legs attach to the rear motor base. One leg attaches to the pump adapter.
5. Industrial design pumps are supplied without legs unless purchased as an option.

Pedestal Mount

1. The correct motor frame for pedestal mount pumps is any standard foot-mounted industrial motor.
2. The pump adapter (same as used for close coupling) attaches to the pedestal instead of the motor face.
3. The pedestal has a through shaft, supported by two bearings, which attaches to the pump impeller shaft on one end, and is coupled to the motor shaft on the other end.

Mounting the Pump to the Motor



CAUTION

Follow instructions for impeller shaft location on the motor shaft. Incorrect location of the impeller shaft may cause the impeller to contact the casing or the backplate during operation and cause extensive damage to the pump.

1. Check the motor G-face surface and the mounting surface of the pump adapter. Make sure the surfaces are clean, smooth, and flat. Remove any high spots due to excess paint.
2. Attach the adapter to the motor using the hex head screws provided.
3. Assemble the remaining pump components as described in the Maintenance section.

Installation

Leveling Close Coupled Mounted Units

1. Install the pump so that the motor and pump are level and all legs are supported equally.
2. If the floor area is not level, disassemble the legs and add stainless steel shim washers to the top of the legs as needed.
3. Secure washers in place by tightening the leg bolt.
4. If the pump is to be installed without legs, attach the motor base firmly to a rigid, level surface.
5. When installing a pump it is very important that proper alignment be maintained between the impeller shaft of the pump and the drive shaft of the motor.

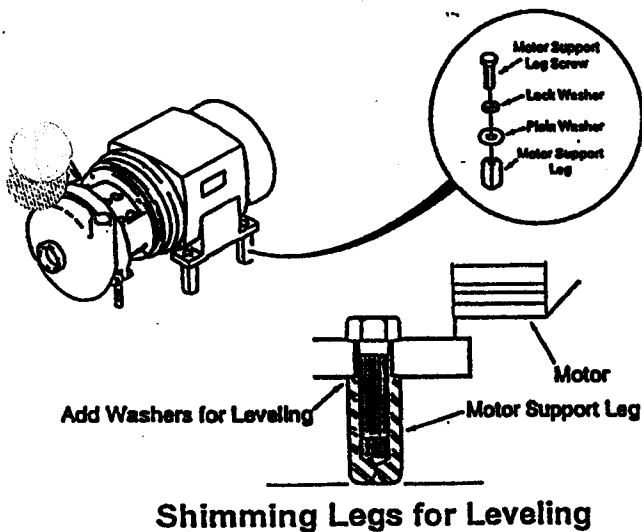

Coupling Alignment

With pedestal mounted units, before starting the pump it is necessary to check the coupling alignment of the pump shaft and the motor or drive shaft.

Check the coupling alignment of the pump shaft and drive shaft in the following instances:

- a. After the pump has been installed and leveled. (Factory supplied couplings are correctly aligned before shipment, however, all bases are flexible to some extent and the effect of shipment may cause a change in alignment)

- b. Any time the drive or pump is removed for service.
- c. Periodically after the unit is installed and operating.

A flexible coupling should not be used to compensate for misalignment of the shafts. The purpose of a flexible coupling is to compensate for temperature changes and to permit end movement of the shafts without interference with each other while transmitting power.

Coupling Misalignment

Coupling misalignment may occur in three forms as shown below.

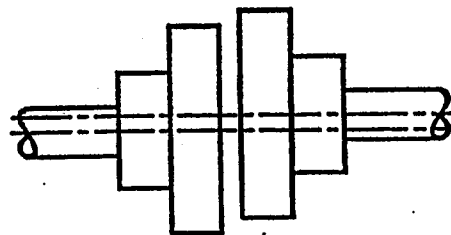

Parallel

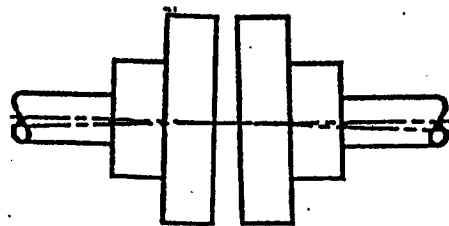

Angular

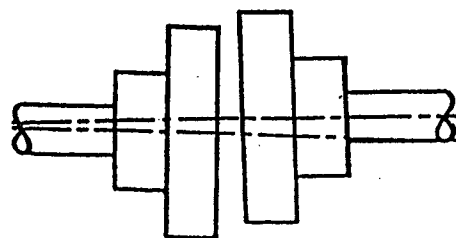

Angular and Parallel

Installation

Checking for Angular Misalignment

1. Rotate the complete coupling 1/4 turn, 1/2 turn, and 3/4 turn.
2. Use a feeler gauge to measure the gap between the coupling halves before each rotation.
3. The maximum recommended difference in measured spacing is .030 in. (0.76 mm).

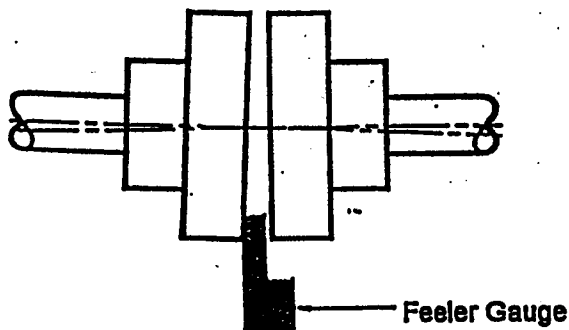

Checking for Angular Misalignment

Checking for Parallel Misalignment

1. Place a straight edge parallel to the shaft axis across both coupling halves.
2. Measure the offset at four places at 1/4 turn intervals around the coupling.
3. Adjust the motor mounting, using shims where necessary to achieve the correct parallel alignment.
4. If adjustments are necessary; be sure to maintain angular alignment.
5. Maximum recommended parallel offset is .015 in. (0.38 mm).

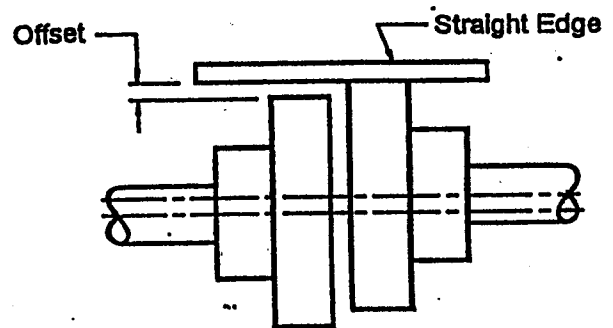

Checking for Parallel Misalignment

Installation

Water Flush Seals

Flooding the seals with water lubricates the seals and prevents build-up of abrasive or crystallized product on seal seat surfaces. Two methods of flushing the seal area with water are available, water to floor and contained.

Water to Floor Flush

1. The cascade-type, water-to-floor, seal flush is available for Type 1, 2, and 3, seals.
2. When this option is ordered, a bracket and tube for directing a flow of water onto the seal/back-plate area is provided.
3. The water supply should be cool and filtered free of any abrasive impurities.
4. Warm or hot water should be used instead of cool water if the product is sticky or crystalline at cool temperatures.

The connection for the flush is 1/8 in. (3 mm) F.P.T.

Contained Water Flush

1. The contained water flush is standard for Type 4 and 5 seals.
2. The flush media piping should include a block valve, filter, and pressure reducing valve.
3. The water supply should be cool and filtered free of any abrasive impurities.
4. Warm or hot water should be used instead of cool water if the product is sticky or crystalline at cool temperatures.
5. The recommended setting for the pressure reducing valve is 5 to 10 psig (.4 to .8 kg/cm²). Flow should be adjusted to approximately 5 gallons (20 liters) per hour.

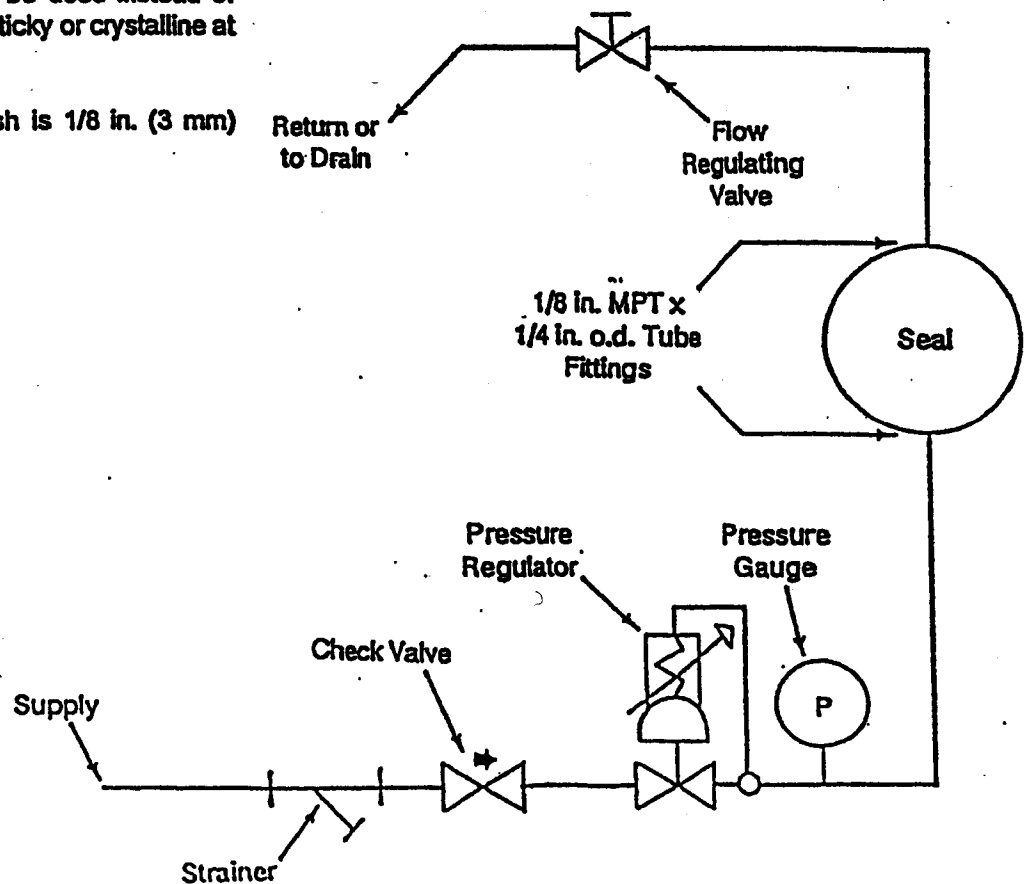

Recommended Contained Water Flush Piping

Pre-Start-Up Procedures

First Cleaning

Disassemble and manually clean all product contact parts and seal parts prior to the first operation. This gives personnel an opportunity to become familiar with the pump assembly. Also, this procedure will remove the protective coating of mineral oil and any foreign materials that may have accumulated during shipment or installation.

See the Maintenance section for complete disassembly and assembly instructions.

See the Cleaning and Sanitizing section for complete cleaning and sanitizing procedures.

Drive

1. Prepare the motor (or other drive) for operation according to instructions provided by the motor manufacturer.
2. Check for correct direction of rotation (counterclockwise when facing the pump inlet).
3. Lubricate the motor bearings per manufacturer's instructions.
4. If the pump was not shipped from the APV Crepaco factory pre-assembled onto a motor or pedestal mount, refer to the Maintenance section for the correct procedure for mounting the impeller shaft onto the motor shaft.

CAUTION

Thoroughly clean all pipe lines to remove all dirt and foreign material before connecting them to the pump. Do not operate the pump for initial flushing of the system after installation. Foreign material may enter the pump and cause damage.

Flush Piping and Pump System

When installing the pump in a new system or with other new equipment in a system:

1. Flush the entire system with solution before operating the pump.
2. Do not use the pump for the flushing. Install a temporary pump(s) for flushing, if necessary:
3. Flushing the system will help remove foreign material which may have accumulated during the manufacture, shipment, and installation of the pump, or other equipment.



CAUTION

Operation of the pump without product will cause damage to the pump.

Pre-Start-Up Procedures



DANGER

Incorrect electrical installation could cause an electric shock which could result in severe injury or even loss of life. All electrical/electronic installation must be performed by trained and authorized electricians only. All electrical/electronic installation must comply with all applicable codes and standards including those established by the Occupational Safety and Health Administration (OSHA).



CAUTION

The pump may overload the motor if operated with a fully open, unrestricted discharge (depending on motor horsepower). Prevent motor damage by checking the discharge pressure before first operation.



CAUTION

Do Not add restriction to the suction line. Operation with restricted suction may cause cavitation and serious damage to pump parts.



CAUTION

When product conditions change (viscosity, density, temperature) or when the process changes (capacity, suction or discharge pressure), the motor load changes also. Re-check the motor load to prevent motor damage.

Check Impeller Diameter vs Motor Horsepower

The performance capability and horsepower requirement of each pump is directly affected by the impeller diameter. Before operating the pump, review the performance curve and application, giving consideration to the motor horsepower and the impeller diameter compared to the expected discharge flow rate and pressure. Certain combinations of motor horsepower and impeller diameter are "non-overloading" when pumping a given fluid. The motor will not overload even if operated with flooded suction and open, unrestricted discharge (conditions for maximum motor load).

Other combinations of motor horsepower and impeller diameter will overload unless operated with sufficient discharge pressure to reduce the amount pumped and limit the motor load. If the pump is operated with less than expected discharge pressure, flow rate will increase and load on the motor will increase.

To determine if there is sufficient discharge pressure to prevent motor overload, perform the following test:

1. If there is no valve in the system downstream of the pump, temporarily install one at a convenient location. The valve should not restrict flow when fully open (for example, a ball valve).
2. Temporarily install an ammeter in the electrical service for the motor.
3. Adjust fluid levels, valves, controls, etc. in the system to simulate anticipated process conditions or cleaning circuits which will result in the lowest discharge pressure and the highest pump flow rate.
4. Close the valve in the discharge line.
5. Start the pump.
6. Gradually open the valve while monitoring the ammeter. If the ammeter indicates full motor load before the valve is fully open, additional restriction is required to prevent motor overload.
7. Trim the impeller or restrict process discharge until the valve may be fully opened without motor overload.

Pre-Start-Up Procedures

Impeller Trimming

1. When a reduced diameter impeller is required, use a factory pretrimmed impeller. These are available through your authorized APV Crepaco representative in a range of standard sizes as detailed in the Service Parts manual.
2. If it is necessary to field trim an impeller, the use of a lathe and standard machine shop procedures are recommended to make sure the impeller is accurately trimmed and balanced.
3. An arbor is required to hold the impeller in the lathe chuck. It is possible to use the impeller shaft supplied with the pump or purchase an arbor kit from APV Crepaco.
4. The impeller material is cast type 316 stainless steel. It is important to machine material equally from all four impeller blades and parallel to the shaft axis. Refer to the Machining Recommendations for Impeller Trimming section.
5. Remove burrs after machining.
6. Check the impeller balance. Refer to the Impeller Balancing section.

Pre-Start-Up Procedures

Machining Recommendations for Impeller Trimming

Field trim the impeller to the required diameter using a 1/32 in. (0.8 mm) radius tool.

1. Rough cut at 211 rpm
Feed Rate .006 in (0.15 mm) per revolution
Depth of cut .040 in. (1.0 mm)

2. Finish cut at 119 rpm (#4 or #6 sizes), 78 rpm (#8 sizes)
Feed Rate .0035 in. (0.09 mm) per revolution
Depth of cut .020 in. (0.5 mm)

Square to be Concentric with Arbor O.D. Within .005 in. (.12mm) T.I.R.

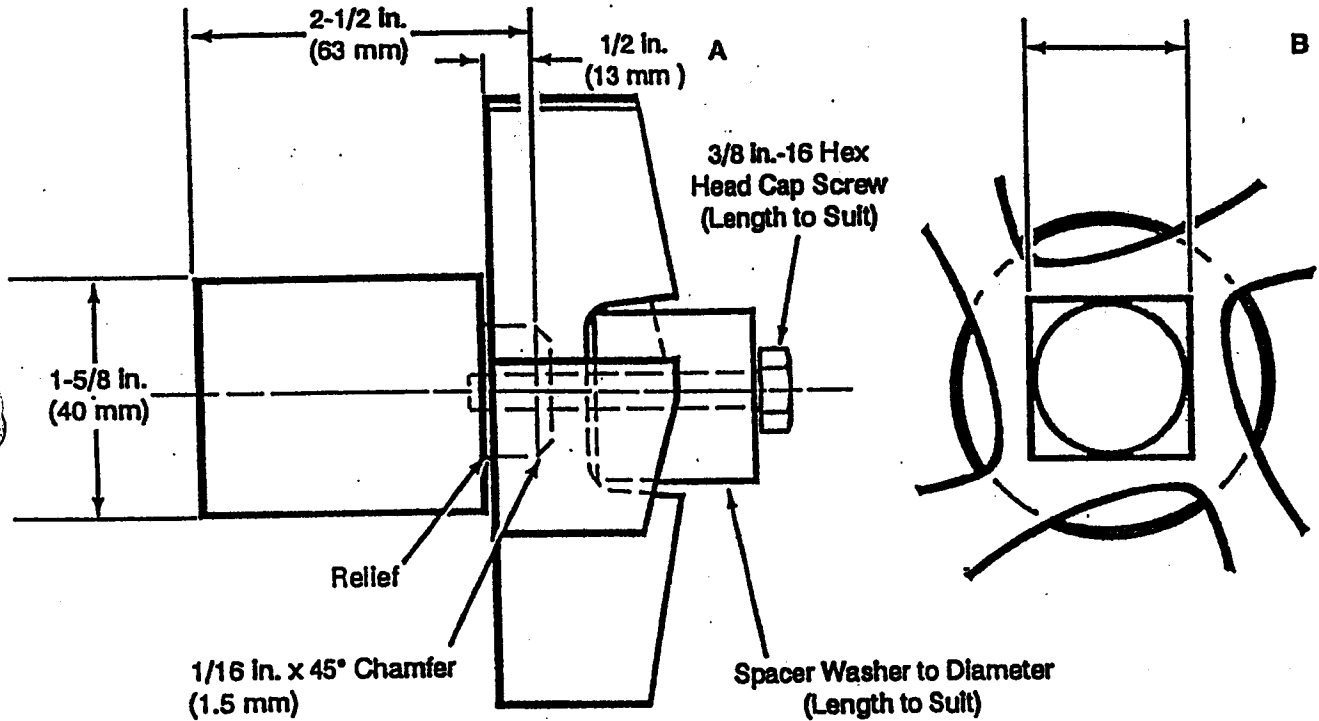

**TRIM ALL FOUR BLADES EQUALLY
PARALLEL TO SHAFT AXIS**

Recommended Arbor Dimensions - Field Manufacture

Pump Model	Kit No.		Untrimmed Impeller Full Diameter	Dimension	
				A	B
4V ² , 14V ²	04W-P-360031	in.	3-13/16	1	0.559/0.561
		mm	97	25	14.20/14.25
6V ² , 16V ² 6VS ² , 16VS ²	04W-P-360032	in.	5-13/16	1-1/4	0.747/0.749
		mm	148	30	18.97/19.02
8V ² , 18V ² 8VS ² , 18VS ²	04W-P-360033	in.	7-13/16	1-1/2	0.997/0.999
		mm	198	37	25.32/25.37

Pre-Start-Up Procedures

Impeller Balancing

Impellers purchased from APV Crepaco, either full diameter or trimmed, are balanced before shipment.

Impellers are trimmed in the field, however, they must be checked for balance before operating the pump.

Out of balance impellers must be field balanced or replaced with factory trimmed impellers.

Specialized equipment is commercially available for checking and correcting the balance of rotating machinery. The use of this equipment is recommended for field balancing of impellers.

One recommended piece of equipment is the "Static Balancing Way". Use the following method to check impeller balance:

1. Mount the impeller shaft with the fastened impeller onto a straight shaft of the same diameter as the motor shaft.

2. Place the shaft across the discs of the balancing way.
3. Rotate the impeller 90 degrees, then release.
4. If the impeller rotates either way of its own accord, it is out of balance; the downward pointing blade being too heavy.
5. Grind off metal from the trailing side of the heavy blade tip.
6. Repeat the procedure until the impeller may be rotated a full 360 degrees in 90 degree increments without any out-of-balance movement.

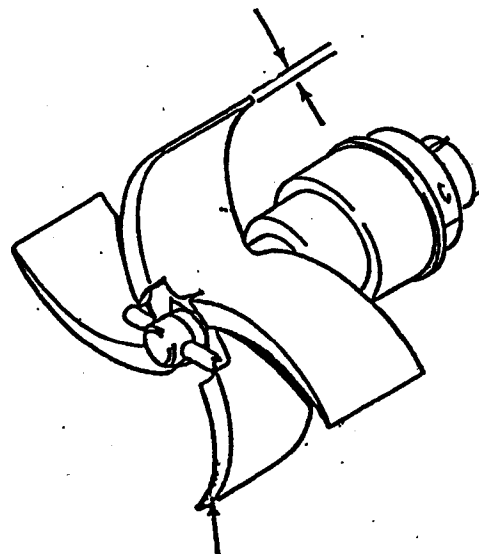
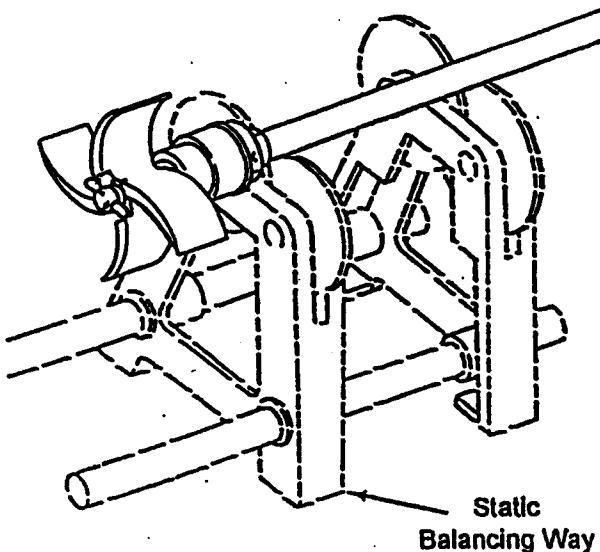

Impeller Balancing Using the Static Balancing Method

Cleaning and Sanitizing



DANGER

During Clean-In-Place (CIP) cleaning procedures the pump may start unexpectedly from a remote signal. This may cause severe injury to anyone in contact with pump parts. Do not contact any part of the pump during Clean-In-Place cleaning procedures. Before disassembling product contact parts for manual cleaning turn off the electric power supply and Lock Out using a locking device for which only the person performing the maintenance procedure has the key.

Cleaning and sanitizing of equipment is necessary on a routine basis whenever processing food products.

The frequency of cleaning and the chemicals and procedures used will vary depending on the product and process. It is the responsibility of the user to establish a suitable, well defined cleaning and sanitizing program. This program must take into consideration all applicable laws, regulations, and standards relative to the protection of public health and the safe use and disposal of chemicals.

For assistance in developing your program, contact your local health authority and a reputable supplier of cleaning and sanitizing chemicals for the food processing industry. You may also contact your local APV Crepaco sales representative for recommendations.

The sanitary models of "V²" Centrifugal Pumps have sanitary design and construction. They are designed with corrosion resistant smooth surfaces and crevice free construction for easy cleaning. In addition, it is easy to disassemble either for manual cleaning methods or for inspection for cleanliness. Depending on the product and cleaning solutions used, it may be possible to satisfactorily clean solely by circulation of chemical detergents and water rinses through the pump (CIP).

Industrial models of "V²" Centrifugal Pumps have identical design features to the sanitary models except for a lesser degree of surface finish. This surface finish may not be considered cleanable by food equipment regulatory agencies.



WARNING

Using unclean or unsanitary equipment may produce contaminated food products. Always clean and sanitize equipment before producing product for human consumption. See the Cleaning/Sanitizing Chemical Hazard in the Safety Information section.



WARNING

Direct contact with cleaning/sanitizing solutions may cause chemical or high temperature burns. Equip all personnel performing cleaning/sanitizing operations with protective clothing (including eye protection). Thoroughly train these personnel in the safe handling and disposal of the chemical and high temperature solutions they are using.



WARNING

When cleaning more than one centrifugal pump in a series in a closed system, the discharge pressures are additive. Pressures higher than normal process pressures are possible. Make sure that all system components are rated for the total pressure of all centrifugal pumps in the cleaning circuit.

Cleaning and Sanitizing

Definitions

Rinse

The purpose of rinsing is to remove excess residual product and reduce the load required for detergent removal. At the end of washing, rinsing removes residual chemical solutions. Without the rinse, the chemicals could be corrosive or react unfavorably with other chemical solutions.

Use a rinse water temperature which rapidly removes the excess product or residual chemical solutions. Generally this means warm water near 100 F (40.0 C). Use potable water for the final rinse.

Detergent Solution

The purchaser is responsible for using the correct chemical solutions. Your supplier of cleaning chemicals should recommend the type of chemical, concentration, temperature, and time of exposure for cleaning with your conditions.

Acid Rinse

Do not use any type of acid in the final rinse water.

Sanitizing

Sanitizing treatments are used to kill microorganisms on product contact surfaces prior to processing food products. Check local health and food regulatory agencies for required minimum sanitizing treatments.

Hot water may be used for sanitizing to avoid the corrosive effect of chemical solutions.

Methods for Cleaning and Sanitizing

General Procedure

The general sequence of steps for cleaning and sanitizing includes:

1. Rinse - Preliminary removal of excess residual product.
2. Wash - Use of detergent solution to remove residual product.
3. Rinse - Removal of residual detergent solution.
4. Sanitize - Treatment with heat or chemical solution prior to product processing to kill bacteria.



CAUTION

Sanitizing solutions are extremely corrosive, especially those which contain halogen compounds (chlorine, bromine, iodine) or strong acids (nitric, hydrochloric). When left in prolonged contact, solutions of these chemicals will attack the stainless steel pump parts. To prevent serious damage:

Do Not sanitize the pump more than 15 minutes immediately prior to starting product processing.

Do Not leave sanitizing solutions in prolonged contact with any surface - product contact or exterior. As droplets dry out they become more concentrated and may cause corrosion pitting.

Do Not use higher concentration, temperature, or exposure time than necessary for effective sanitizing treatment.

Clean-In-Place, (CIP) Cleaning Method

CIP is cleaning solely by flowing rinse, detergent, and sanitizing solutions through the product contact areas at high velocity. The solutions must be supplied from a separate source such as a central CIP system.

When using CIP methods for cleaning and sanitizing it is necessary to operate the pump during circulation of solutions.

At the end of cleaning, thoroughly rinse all pump parts with clean water.

With CIP methods, it is necessary to periodically disassemble the pump to check for cleanliness and the effectiveness of the CIP cleaning. Manually clean when necessary.

Cleaning and Sanitizing

Manual Cleaning Method

Manual cleaning means that the application of rinses, detergents, and sanitizing solutions is done by hand. For example, rinse water may be sprayed over product contact surfaces with a hose and detergent solution may be scrubbed on with a brush.



CAUTION

Using the wrong cleaning tools will damage product contact surfaces. Never use steel wool or a wire brush. Use a nonmetallic brush.

Shaft Seals

The "V²" pump is available with five different seal types, 1, 2, 3, 4, and 5, to accommodate various applications.

Options in seal seat and O-ring materials are available in each seal type. Selection of the seal type and materials is determined by the characteristics of product being pumped.

For products containing abrasives or where products may crystallize, caramelize, or build up at the sealing surface, flooding the seals with water lubricates the seals and prevents build-up of abrasive or crystallized product. The cascade-type, water-to-floor, seal flush is available for Type 1, 2, and 3 seals. The contained water flush seal is available for Type 4 and 5 seals.

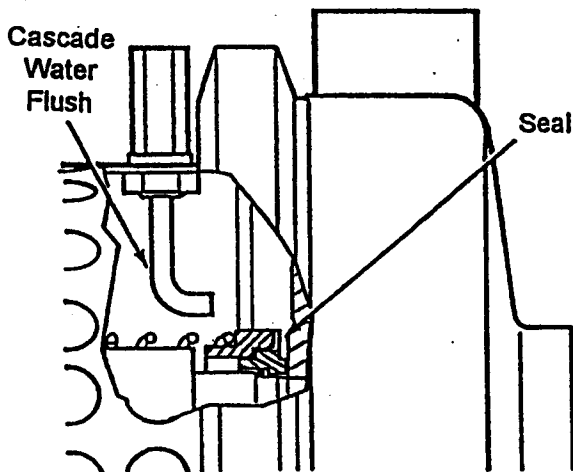

Cascade Water Flush

Type 1 - Product Seal (Standard)

A hydraulically balanced seat ring rotates against the backplate. The seat ring is positively driven by an interlocking drive ring. A Nitrile rubber O-ring seals between the seat ring and the shaft. Alternate materials are available for the seat ring and the O-ring as noted in the Service Parts section.

Type 2 - Product Seal with Replaceable Insert

The rotating seat ring is the same as the Type 1. The backplate has a replaceable seat (insert) at the wearing surface. The standard seat is constructed of Type 17-4 PH stainless steel and may be reversed for extended wear life. The O-ring, seat ring, and replaceable seat materials are available as noted in the Service Parts section.

Type 3 - John Crane™ Seal with Replaceable Insert

The rotating seat is a John Crane™ Type 8B1. The backplate has the same replaceable seat as described for Type 2.

The John Crane™ 8B1 seal features hydraulically balanced carbon seat, 316 stainless steel metal parts, and nitrile O-ring for sealing on the shaft. Alternate O-ring and replaceable seat materials are available as noted in the Service Parts section.

Type 4 - Contained Water Flush - John Crane™ Seal with Replaceable Insert

The Type 4 seal arrangement is designed for contained water flushing. The same John Crane™ 8B1 rotating seal and replaceable backplate seat described for the Type 2 seal are used. In addition, a second John Crane™ Type 8B2 seal is used to seal the rear of the water flush chamber. Alternated O-ring, replaceable seat, and stationary seat materials are available as noted in the Service Parts section.

Type 5 - Contained Water Flush - Product Seal and John Crane™ Rear Chamber Seal with Replaceable Insert

This seal arrangement is a water flush design similar to Type 4 except that the rotating seat ring is the same seat as described for the Type 1 seal. Alternate O-ring, seat ring, replaceable seat, and stationary seat materials are available as noted in the Service Parts section.

Shaft Seals

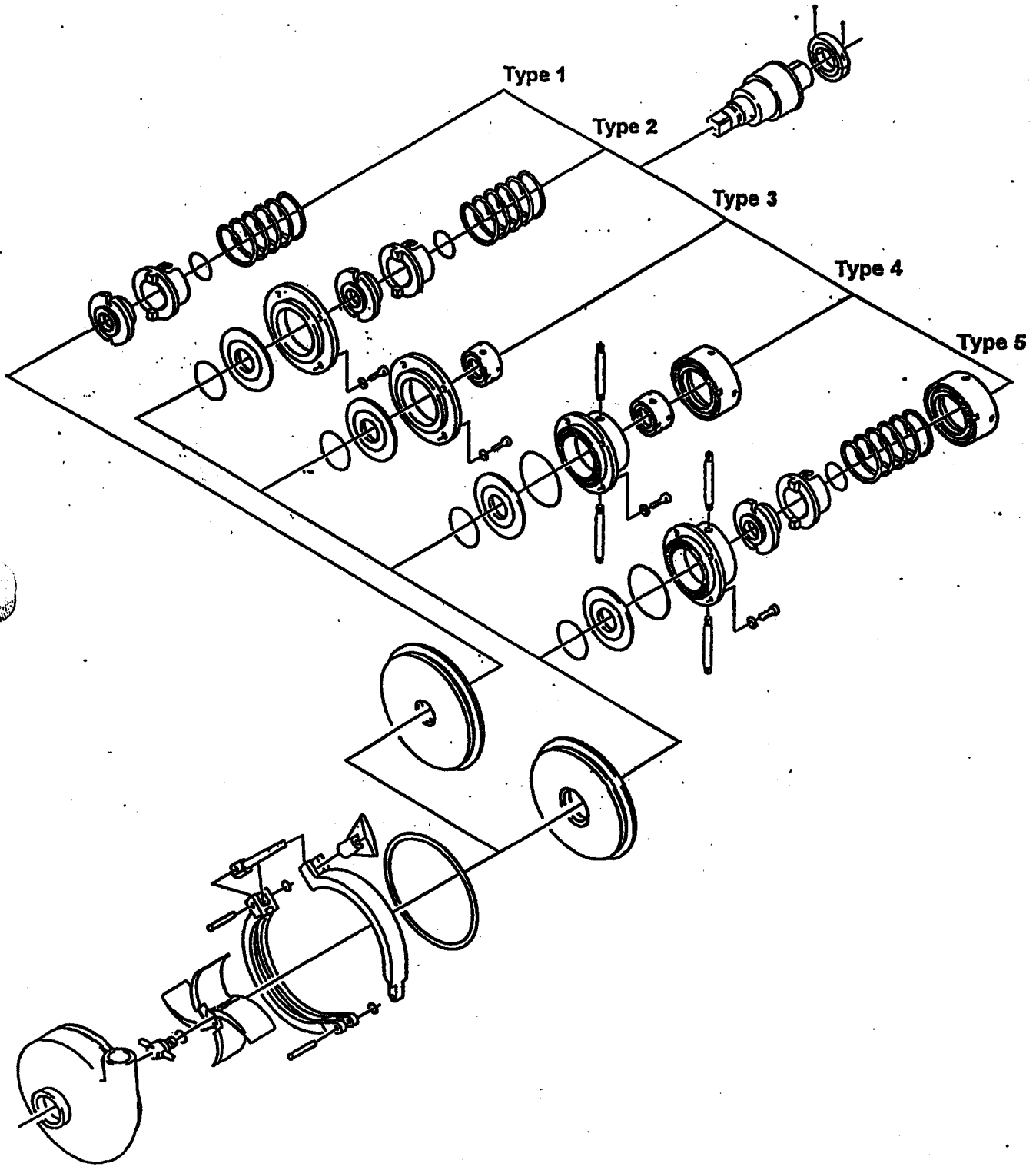

Shaft Seal Components

Theory of Operation

The "V²" Centrifugal Pump is designed for pumping low to medium viscosity fluids.

1. The pump design is horizontal, with fluids entering the casing through the end suction inlet.
2. The casing is attached to the backplate with a clamp ring assembly for convenient access to the impeller. The proprietary tapered clamp design provides improved sealing by holding the casing and backplate tight against the adapter.
3. The casing is made of a heavy, single piece investment casting with uniform wall thickness and dimensional accuracy for reliable, distortion-free high pressure service. The volute design provides high efficiency over a wide range of operating conditions.
4. The backplate is heavy duty to resist water hammer and cavitation. The thick cross section accommodates five standard seal types and may include a replaceable seat which can be reversed to double its wear life.
5. The impeller propels the fluid to a top discharge outlet. The impeller is fully-open, 4-blade, and has a reverse curve configuration.
6. The impeller is driven by a precision machined impeller shaft. It is secured to the motor shaft by two set screws and is key driven.
7. The pump is designed for a variety of operating speeds. Electric motors that operate at 3500 or 1750 rpm are generally used. The electric motor is customer supplied.

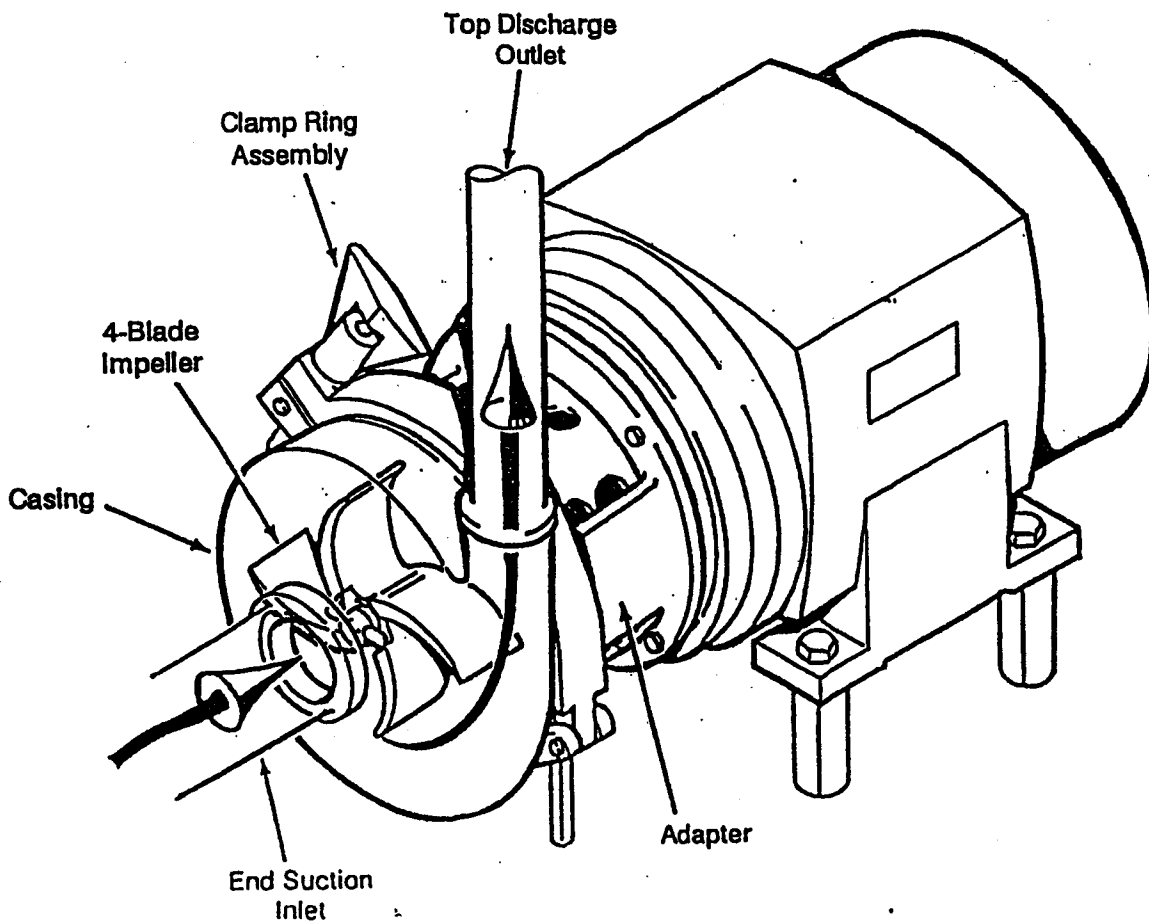

Pump Design

Theory of Operation

8. Product is sealed by a mechanical seal, available in five standard types. The basic Type 1 seal is a single, externally mounted design with a rotating carbon seat against a stationary type 316 stainless steel backplate. All seals are hydraulically balanced and positively driven.

Various seal seat material combinations are available to correspond to the pump application.

9. Two of the standard seal types are double mechanical seals for contained water flush.

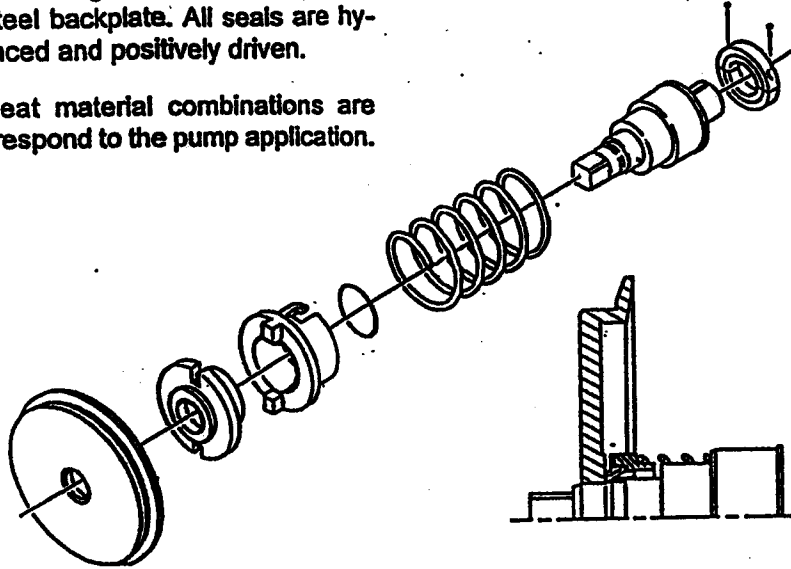

Single Mechanical - Type 1 Seal

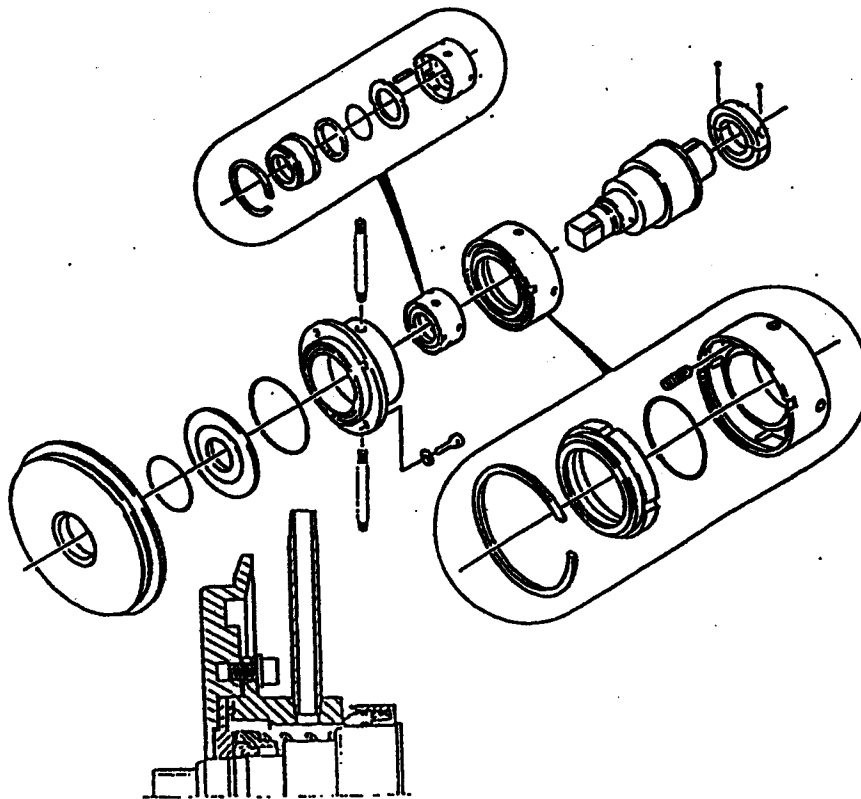

Double Mechanical - Type 4 Seal

Operation

Pump Operation

After all the procedures in the Pre-Start-Up section have been performed, the pump is ready to start.

1. If the pump is equipped with a flush shaft seal, start the flush media flowing. See the Installation section for recommendations on flow rate, pressure, and water quality.
2. Open the suction line and flood the pump casing with liquid before starting the pump drive.

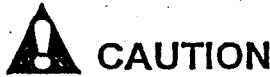

Continuous operation of the pump without liquid present will damage the shaft seal. Starting the pump "dry", then admitting liquid will cause mechanical damage to the pump and drive.

3. Start the pump drive. Check to see that flow is established and that connections and seals are not leaking.

Operating the pump with closed discharge is permissible for short periods depending on the type of product and its temperature. Under these conditions, mechanical heat is added to the product and it eventually will vaporize (boil).



Do Not allow the pump to operate continuously with closed discharge. Heat will build up, leading to damage of pump parts.

4. If normal pump operation includes valve openings and closures (especially automatic air or solenoid operated valves) check for evidence of water hammer. Water hammer is a sudden, extreme increase in pressure due to rapid changes in the velocity of a liquid flowing through a pipe line. If damaging water hammer is present, there will be noticeable line or pump movements and noise when valves are operated. Any water hammer detected must be corrected to prevent unwarranted mechanical failures. One method of preventing water hammer is to slow the rate of valve operation to provide gradual openings and closings.



The pressure caused by water hammer could far exceed normal operating discharge pressure and may be mechanically damaging to the pump and other system components.

5. Valves in the suction lines should never be closed or throttled during pump operation.
6. Stop the pump drive when pumping is completed. Do not allow the pump to continue running "dry".

Maintenance

Component Identification

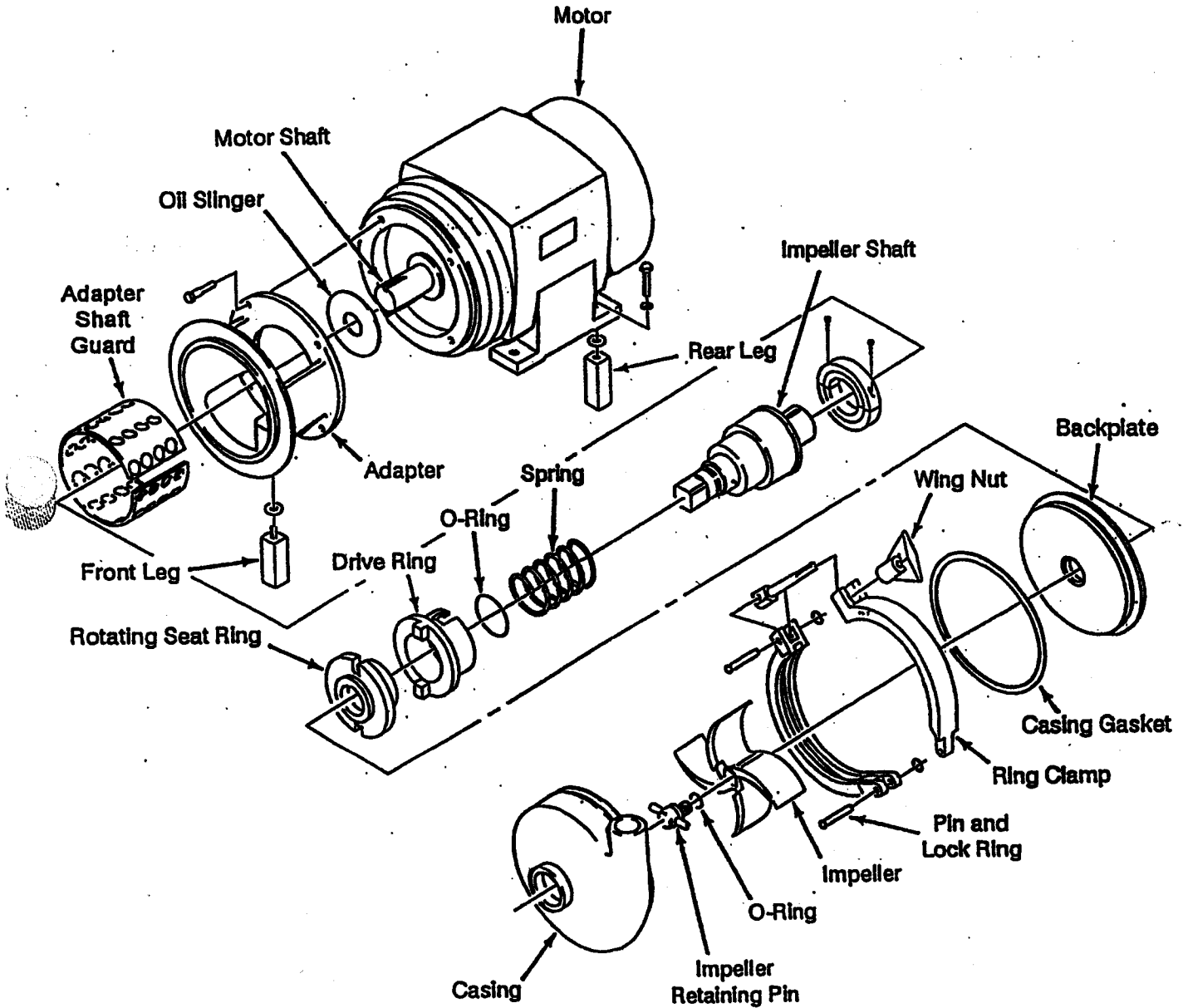

Pump Component Identification

Maintenance

Casing and Impeller



DANGER

The pump shaft and impeller operate at high speed and can cause severe injury or even loss of life if contacted when operating.

The electric motor creates a hazard of electric shock which can cause severe injury or even loss of life if contacted while energized.

Turn off the drive power supply and Lock Out to prevent accidental starting before disassembling the pump or drive to perform maintenance.

Use a Lock Out device for which only the person performing the maintenance procedure has the key.



WARNING

Liquid in the pump casing may be under pressure. Some liquids may be harmful if contacted (hot liquids, chemical cleaning solutions, etc.). Pump disassembly will allow any pressurized liquid present to spray out and possibly contact personnel in the area. Shut off all sources of liquid to the pump and drain the casing before starting pump disassembly. Remember that liquid may "Backup" through the discharge line.

Disassembly

1. Disconnect the inlet and discharge piping.
2. Loosen the wing nut and remove the clamp ring assembly.

3. Gently pull off the casing and casing gasket.
4. Unscrew the impeller pin by turning counterclockwise.
5. Remove the impeller pin O-ring.
6. Remove the impeller by grasping the impeller vane tips. Tap with a soft faced mallet if necessary to loosen. Do not pry between the impeller and the backplate.

Assembly

1. While holding the backplate into position against the shaft seal, install the impeller onto the impeller shaft.
2. Using a light oil, lightly lubricate the impeller retaining pin O-ring and install it on the impeller shaft.
3. Lightly lubricate the retaining pin threads with a light oil and insert the retaining pin into the impeller shaft.
4. Using finger pressure only, tighten the pin clockwise until the pin is firmly against the impeller.
5. With a light oil, lubricate the casing gasket and install it into the recess of the backplate.
6. Install the casing over the impeller and against the backplate and casing gasket.
7. Position the clamp ring assembly around the casing, backplate, and adapter.
8. Using finger pressure, tighten the wing nut securely against the ring clamp.
9. Connect the inlet and discharge piping.
10. If the pump has flush seals, connect the inlet and outlet flush piping.

Maintenance

Backplate

Disassembly

1. If the pump is equipped with a flush seal, disconnect the inlet and outlet flush fittings.
2. Remove the backplate from the adapter.
3. If the backplate is equipped with a replaceable seal insert, loosen and remove the socket head cap screws and lock washers from the seal insert ring.

If the seal is Type 3, 4, or 5, remove the socket head cap screws and lock washers from the water seal chamber.

4. Remove the seal insert ring or water seal chamber.
5. Remove the O-ring from the water seal chamber.
- Remove the seal insert from the backplate.
7. Remove the O-ring from the seal insert.
8. Remove the adapter shaft guard from the adapter to access the impeller shaft.



WARNING

The adapter guard must be in place any time the pump is operated.

Assembly

1. Fit the adapter shaft guard into the adapter.
2. If the backplate is equipped with a replaceable seal insert, install the seal insert O-ring into the groove on the backplate.
3. Place the seal insert into the backplate.
4. If the pump has a Type 4 or 5 contained flush outer seal, insert the O-ring into the water seal chamber.
5. Position the insert holder ring or water seal chamber into the backplate.
6. Install the lock washers and socket head cap screws through the insert holder ring or water seal chamber and into the backplate, tightening all screws uniformly.
7. Clean and lightly lubricate the backplate or backplate insert seat facing surface.

If the pump has a water seal chamber, clean and lightly lubricate the stationary seat mating surface.

8. Carefully push the assembled backplate onto the impeller shaft and against the seat ring face, compressing the seal springs.
9. Hold the backplate in this position while installing the impeller and impeller pin.

Maintenance

Product Seals - Type 1, 2, and 5 Shaft Seals

Disassembly

1. Remove the rotating seat ring and the drive ring together from the impeller shaft by grasping the outside, pushing in slightly, then turning counter-clockwise to disengage the drive ring slot from the pin on the impeller shaft.
2. Remove the O-ring from the rotating seat ring.
3. Separate the rotating seat ring and drive ring.
4. Remove the spring from the impeller shaft.

Assembly

1. Place the seal spring onto the impeller shaft.
2. Place the seat ring and the drive ring together.
3. Lightly lubricate the O-ring with a light oil and install it into the recess in the seat ring.
4. Wipe the seat ring face area clean and lubricate it lightly with a light oil.
5. Push the seat ring and drive ring onto the impeller shaft, compressing the spring.
6. Engage the drive ring slot with the pin on the impeller shaft and turn clockwise to hold the assembly into place.



CAUTION

Handle seal components carefully. Seal seats may break if mishandled or dropped. Handle carbon seat rings with care to prevent chipping or breaking.

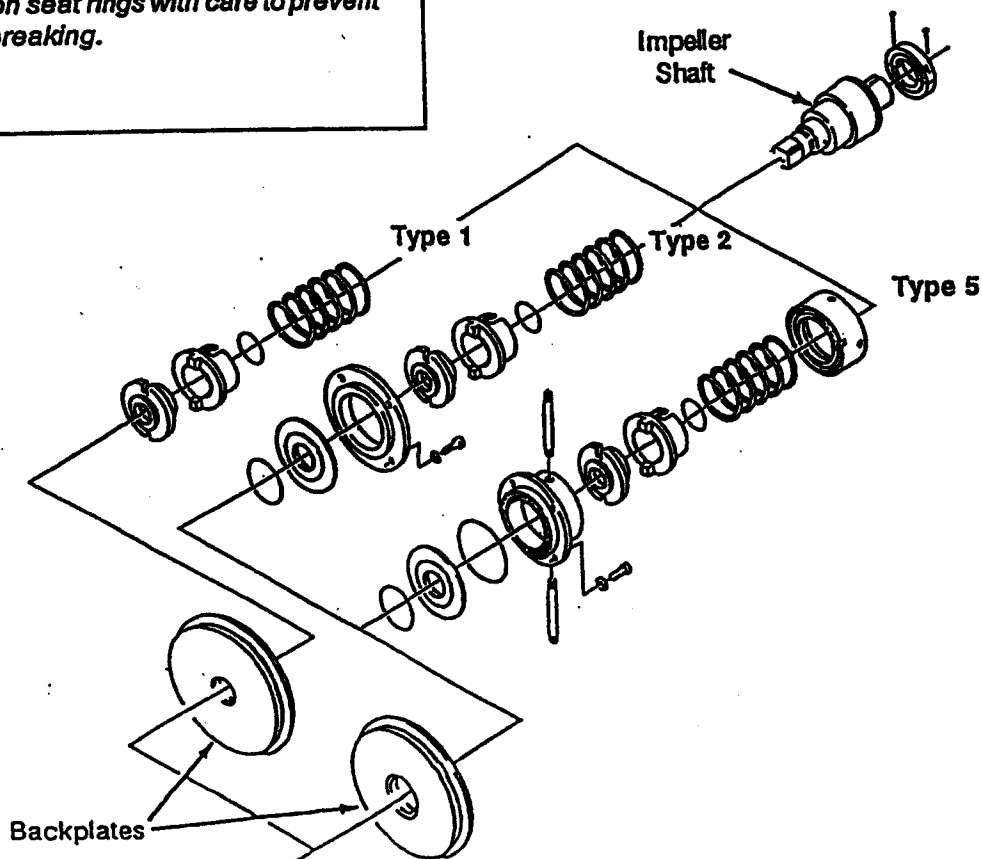

Product Seal - Types 1, 2, and 5 Disassembly and Assembly

Maintenance

John Crane™ Mechanical Seal Type 3 and 4 Shaft Seals

Disassembly



CAUTION

Handle seal components carefully. Seal seats may break if mishandled or dropped. Handle carbon seat rings with care to prevent chipping or breaking.

1. To remove the John Crane™ mechanical seal assembly from the impeller shaft, loosen all the set screws.
2. Pull the seal assembly off the shaft.

Do Not disassemble further unless replacing the carbon seat ring or the O-ring.

To completely disassemble the John Crane™ mechanical seal, place the assembly on a work surface with the carbon seat ring facing up.

4. Carefully push down on the seat ring face with the palm of your hand, compressing the springs.
5. Remove the retaining ring by starting it with a small screwdriver through the slot in the outer retainer.
6. All parts are now free to disassemble.

Assembly

If the seal assembly has not been disassembled to replace the carbon seat ring or the O-ring, go to step 7.

1. Place the outer retainer on a work surface with the carbon seat ring side facing up.
2. Insert the springs into the holes of the retainer.

The John Crane™ seal for the rear of the water chamber in Type 4 seal will have one-half the number of springs as there are holes for springs in the outer retainer. When reassembling, space the springs evenly by placing them into every other hole.

3. Insert the spring spacer ring into the retainer over the springs. This applies only to the interior John Crane™ seal.
4. Lightly lubricate the O-ring with a light oil and install it into the groove in the carbon seat ring.
5. Wipe the seat ring face area clean, lubricate it lightly with a light oil and install the seat ring into the retainer.
6. Carefully push down on the seat ring face with the palm of your hand compressing the springs. to insert the retaining ring.
7. Push the seal assembly onto the impeller shaft and up against the shoulder on the shaft.
8. Uniformly tighten all the set screws.

Maintenance

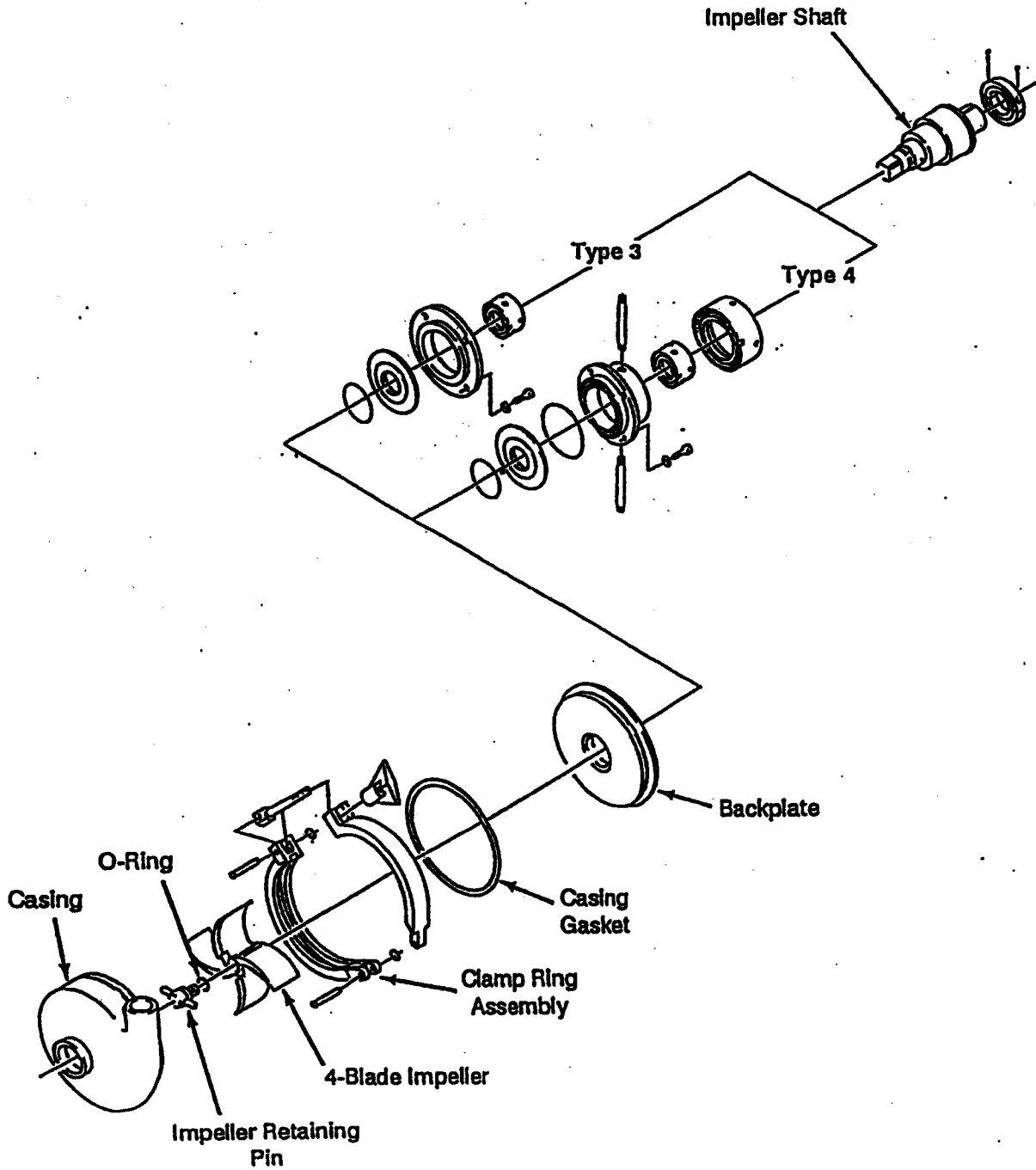

John Crane™ Mechanical Seal – Types 3 and 4 Disassembly and Assembly

Maintenance

Impeller Shaft

Disassembly

1. Loosen the impeller shaft screws.
2. Remove the impeller shaft from the motor shaft.
3. Remove the oil slinger from the motor shaft.
4. Loosen and remove the hex head cap screws from the adapter.
5. Remove the adapter from the motor face or the pedestal mount.

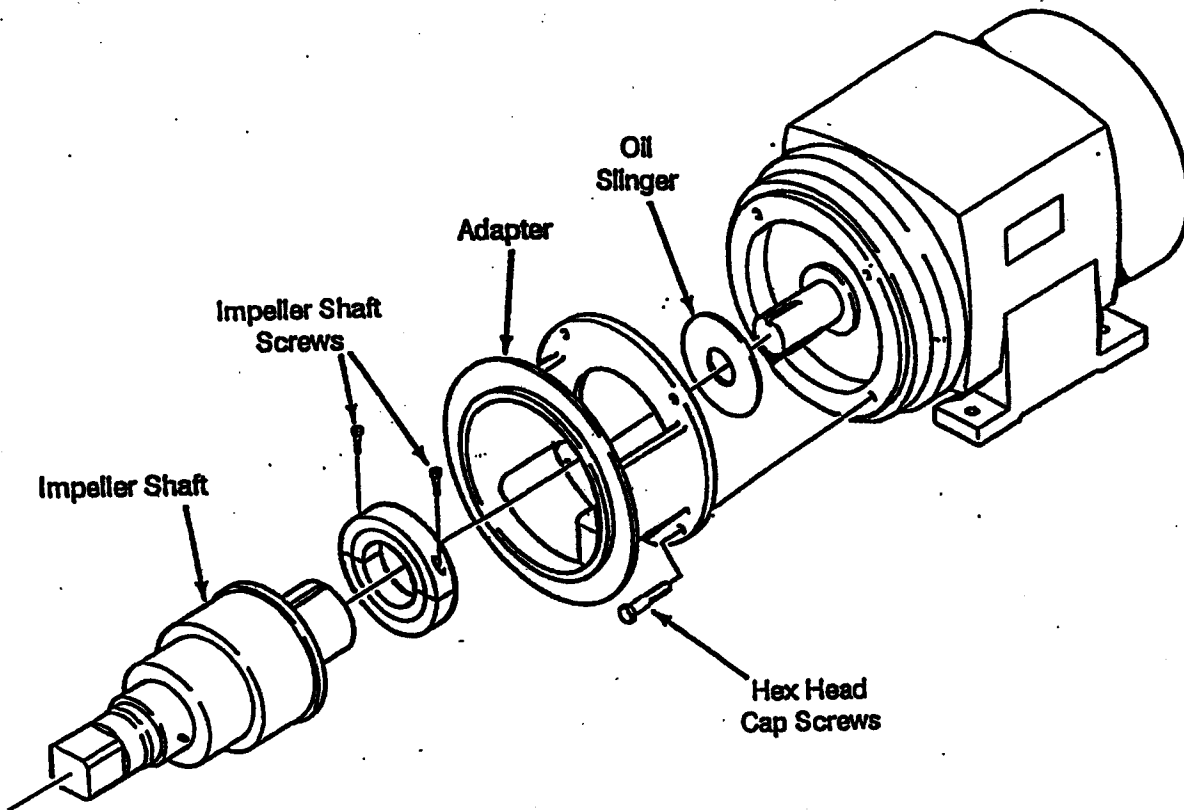

Impeller Shaft Disassembly

Maintenance

Assembly

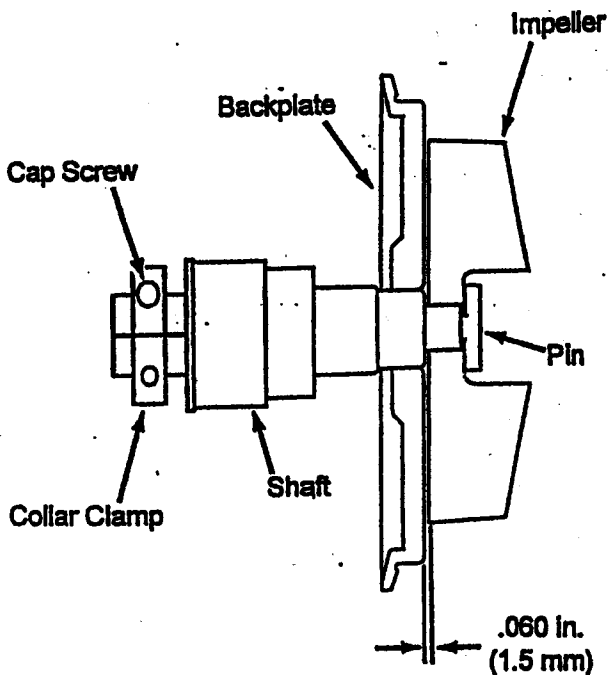

Impeller Shaft Assembly

All motors used for centrifugal pump assembly must have limited end-play bearings.

Before assembly, runout of the impeller shaft must be checked. Perform steps 2, 3, and 9 in succession, then check the shaft for runout. Total runout of the shaft must not exceed .005 in. (.13 mm). Loosen the collar screws and disassemble.

CAUTION

Correct location of the impeller shaft on the motor shaft is critical to prevent damage to pump parts and to obtain maximum operating efficiency.

1. Attach the motor adapter to the motor face or to the pedestal assembly.
2. Slide the collar over the motor shaft, but do not tighten the screws.
3. Slide the impeller shaft onto the motor or pedestal shaft and slide the collar over the scarf-cut part of the shaft. (Make sure the motor shaft and the impeller shaft are clean). Again, do not tighten the collar screws.
4. Place the backplate over the pump shaft and up against the motor adapter.
5. Attach the impeller onto the impeller shaft and tighten the impeller pin.
6. Clamp the backplate firmly against the motor adapter, making sure the backplate is even.
7. Move the impeller shaft until there is .060 in. (1.5 mm) clearance between the impeller and the backplate.
8. Position the clamp collar over the middle of the scarf-cut portion of the impeller shaft, making sure the slots in the collar and shaft are aligned. Tighten the screws using 90 in./lb. Torque for 3/16 in. screws; 190 in./lbs. for 1/4 in. screws.
9. Disassemble the impeller and the backplate. Reassemble the pump with all of the seal components in the correct locations.

Maintenance



WARNING

Liquid in the pump casing may be under pressure. Some liquids may be harmful if contacted (hot liquids, chemical cleaning solutions, etc.). Pump disassembly will allow any pressurized liquid present to spray out and possibly contact personnel in the area. Shut off all sources of liquid to the pump and drain the casing before starting pump disassembly. Remember that liquid may "Backup" through the discharge line.



DANGER

The pump shaft and impeller operate at high speed and can cause severe injury or even loss of life if contacted when operating.

The electric motor creates a hazard of electric shock which can cause severe injury or even loss of life if contacted while energized.

Turn off the drive power supply and Lock Out to prevent accidental starting before disassembling the pump or drive to perform maintenance.

Use a Lock Out device for which only the person performing the maintenance procedure has the key.

Routine Wear Checks

Routinely disassemble the pump and check the pump components for wear and deterioration.

Replace any pump component which has evidence of damage which could interfere with the pump operation.

Casing Gasket

Replace at any sign of leaking, deterioration, cracking, or change in dimension.

Impeller Retaining Pin

Check the threads. Replace the impeller pin if the threads are damaged or worn.

Impeller Retaining Pin O-ring

Replace at any sign of leaking, deterioration, cracking, loss of elasticity, or change in dimension.

Impeller and Impeller Shaft

1. Check for wear between the impeller shaft and the impeller hub. If "rocking" the impeller on the shaft allows the impeller blade tips to touch or nearly touch the backplate, replace the impeller and or the impeller shaft.
2. A feeler gauge may be used to measure the clearance between the hub and the shaft. Excess wear is present when the clearance is .01 in. (.25 mm) or more.

3. Check the spacing between the impeller and the backplate. Refer to the Impeller Shaft Assembly in this section for the procedures. Relocate the impeller shaft if the spacing is incorrect.

Backplate

1. Check the backplate seal area or insert for wear.
2. Replace the backplate or insert when wear is such that a smooth, flat surface for sealing cannot be assured.
3. Backplate inserts may be reversed when the first side becomes worn.

Maintenance

Shaft Seal Components



CAUTION

Handle seal components carefully. Seal seats may break if mishandled or dropped. Handle carbon seat rings with care to prevent chipping or breaking.

1. Check the rotating seat ring and replace the seat ring when the raised face is worn or chipped.
2. Check the seal O-rings and replace at any sign of leaking, deterioration, cracking, loss of elasticity, or change in dimension.
3. Check the spring in the inner Type 1, 2, and 5 seals to make sure that it fits onto the drive ring and impeller shaft.
4. If the pump is equipped with a contained water flush seal, check the water flush seals components for signs of wear or deterioration.

Pedestal Mounted Pumps

Check the bearings for looseness or other evidence of wear.

Lubrication

Motor

Lubricate motor (or other drive) according to instructions provided by the manufacturer.



CAUTION

When pumping product above 200 F (93 C), consult the motor manufacturer for high temperature lubricant recommendations.

Pump Components

When processing food products use a sanitary grade lubricant in product contact areas. Use a lubricant approved for incidental contact with edible products (USDA Classification H1).

1. Lightly lubricate seal seat face areas (rotating and stationary) when assembling. Use a small amount of light oil. Do not use solid or grease type lubricants.
2. Use a small amount of light oil to lubricate the O-ring under the seal ring and the impeller retaining pin O-ring when assembling.

Pedestal Mounted Pumps

1. Pedestal mounted pumps have two pre-lubricated bearings. Under normal conditions of use, the bearings should require no further lubrication for the life of the bearing.
2. Under severe operating conditions, such as continuous service, high ambient temperature, or an extremely wet or dirty environment, lubricate the bearings every four months.
3. To lubricate, remove the slotted pipe plugs and install grease fittings with 1/8 in. I.P.S. threads.
4. Use a good quality lithium base grease. DO NOT over grease. Add only enough grease to make sure the fresh grease is getting into the bearings.
5. Wipe off any old or excess grease from the outside.

Problem Solving Guide

Problem	Possible Cause	Possible Reason
Not enough liquid delivered	Impeller diameter too small for application	
	Discharge head too high	
	Suction lift too high	
	Air leak in suction or at seal area	
	Wrong direction of rotation	
	Pump not primed	
	Speed too slow	
		Wrong frequency
		Wrong motor
		Suction or discharge plugged or closed
	Air in liquid	
	Insufficient NPSH (net positive suction head) available	
Not enough pressure	Impeller diameter too small for application	
	Air leak in suction or at seal area	
	Wrong direction of rotation	
	Speed too slow	Low voltage
		Wrong frequency
		Wrong motor
	Air in product	
Rapid seal wear	Abrasive product	Incorrect impeller shaft location
	Excessive spring loading	
	Abrasive solids (unfiltered) in seal flush media	
	Incorrect seal assembly	
	Loose impeller shaft	
	Prolonged "dry" running	
	Water hammer	

Problem Solving Guide

Problem	Possible Cause	Possible Reason
Motor overload	Discharge head too low allowing pump to deliver too much liquid	
	Impeller diameter too large for application	
	Liquid heavier or more viscous than rating	
	Voltage or frequency incorrect	
	Mechanical abnormality in pump	Impeller interference
		Seal binding
		Bad bearing in pedestal mount
	Defective motor	
	Faulty electrical connections	
	Overload heaters too small for motor	
Vibration	Starved suction	Insufficient NPSH (net positive suction head) available
		Suction line too long
		Suction line too small
		Suction line blocked
		Air in liquid
		Liquid too hot or too viscous
	Impeller shaft loose or bent	
	Impeller out of balance	
	Impeller loose on impeller shaft	
	Motor bearings worn	
	Base not level, legs not touching floor	



Parts Manual V² Series Centrifugal Pump



Read and understand this manual prior to operating or servicing this product.



1 1/2" Series Sanitary Centrifugal Pump
Models 4V², 6V², 6VS², 8V², 8VS²

STANDARD

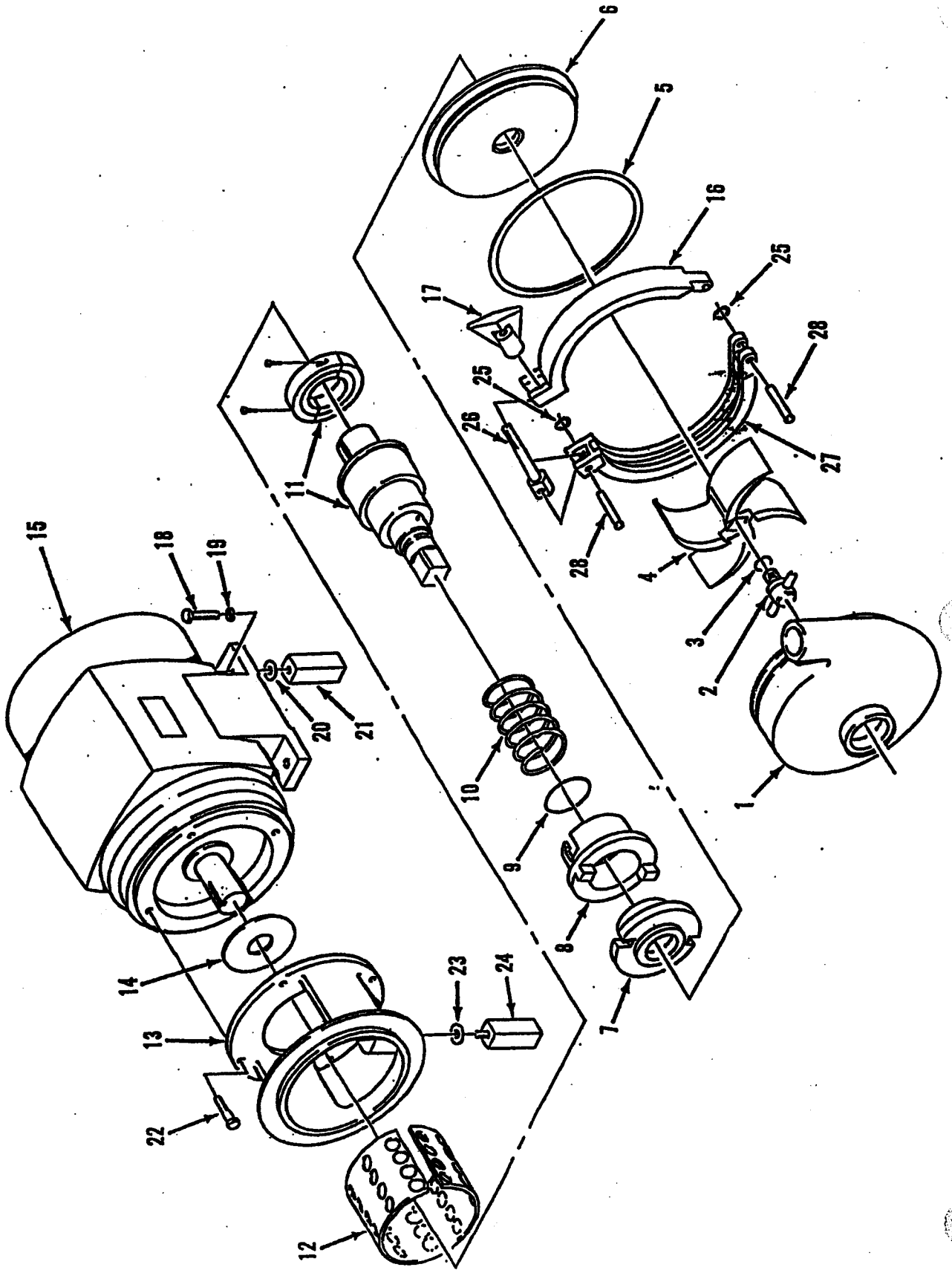

"V2" Series Sanitary Centrifugal Pump
Models 4V², 6V², 8V², 8VS²

STANDARD

ITEM	DESCRIPTION	4V ² PART NO.	QTY.	6V ² PART NO.	QTY.	6VS ² PART NO.	QTY.	8V ² PART NO.	QTY.	8VS ² PART NO.	QTY.
1	CASING - Sanitary Pump	*04HP414205	1	*04HP414217	1	*04H452222	1	*04AP414223	1	*04AP414235	1
2	PIN	727P411442	1	727P411443	1	727P411443	1	727P411443	1	727P411443	1
3	O-RING	*643S131305	1	*643S131305	1	*643S131305	1	*643S131305	1	*643S131305	1
4	IMPELLER - Sanitary (full length)	*04HP342252	1	*04HP339690	1	*04HP452236	1	*04HP342740	1	*04HP343874	1
5	GASKET - Beaded	*04HP188082	1	*04HP188619	1	*04HP188619	1	*04HP188168	1	*04HP188168	1
11	SHAFT - Impeller (refer to Seal Type section)	04HP469328	1	*	1	*	1	*	1	*	1
12	GUARD	04HP410281	1	*	1	*	1	*	1	*	1
13	ADAPTER	*	1	*	1	*	1	*	1	*	1
14	SLINGER - Oil	N/A	1	N/A	1	N/A	1	N/A	1	N/A	1
15	MOTOR (see MOTOR note below)	727P342246	1	727P339707	1	727P339707	1	727P342761	1	727P342761	1
16	RING - Clamp	727P339252	1	727P339252	1	727P339252	1	727P339252	1	727P339252	1
17	NUT - Wing	**521V006974	2	*	2	*	2	*	2	*	2
18	SCREW - Hex Head Cap (ss) (pkg of 5)	**523V007185	2	*	2	*	2	*	2	*	2
19	WASHER - Lock (ss) (pkg of 10)	**523V007177	2	*	2	*	2	*	2	*	2
20	WASHER - Plain (ss) (pkg of 10)	04HP414608	2	*	2	*	2	*	2	*	2
21	LEG - Rear	**522V006782	4	**523V007178	1	**523V007178	1	**523V007179	1	**523V007179	1
22	SCREW - Hex Head Cap (zinc plated)	**523V007178	1	**523V007178	1	**523V007178	1	**523V007179	1	**523V007179	1
23	WASHER - Plain (ss) (pkg of 10)	04HP414181	1	*	1	*	1	*	1	*	1
24	LEG - Front	**543P119914	2	**543P119914	2	**543P119914	2	**543P119914	2	**543P119914	2
25	RING - Lock (pkg of 10)	04HP337283	1	04HP337283	1	04HP337283	1	04HP337283	1	04HP337283	1
26	PIN - Pivet	727P342248	1	727P339709	1	727P339709	1	727P342762	1	727P342762	1
27	RING - Clamp	727P342248	2	**525P119916	2	**525P119916	2	**525P119915	2	**525P119915	2
28	PIN (pkg of 10)	**525P119916	2	**525P119916	2	**525P119916	2	**525P119915	2	**525P119915	2

MOTOR: When ordering a motor or motor parts, specify the complete motor name plate information.

*See the Options section for customer option.

**Certain items are packaged in minimum quantity lots as indicated.

***Use siliconized carbon seat ring only with silicon carbide seal insert.

Rev. 10/1/96

"V²" Series Sanitary Centrifugal Pump
 Models 4V², 6V², 6VS², 8V², 8VS²

OPTIONS

ITEM	DESCRIPTION	4V ² PART NO.	QTY	6V ² PART NO.	QTY	6VS ² PART NO.	QTY	8V ² PART NO.	QTY	8VS ² PART NO.	QTY
1	CASING - 1-1/2 in. Inlet x 1-1/2 in. Outlet										
	Butt Weld	04HP414205	1	N/A		N/A		N/A		N/A	
	Bevel Seat	04AP414207	1	N/A		N/A		N/A		N/A	
	Tri Clamp	04AP414208	1	N/A		N/A		N/A		N/A	
	APC-PV	04AP414209	1	N/A		N/A		N/A		N/A	
	APC-Clamp	04AP414210	1	N/A		N/A		N/A		N/A	
	APV SP (ISS)										
1	CASING - 2 in. Inlet x 1-1/2 in. Outlet										
	Butt Weld	04HP414211	1	04HP414217	1	N/A		04HP414229	1	N/A	
	Bevel Seat	04AP414212	1	04AP414218	1	N/A		04AP414230	1	N/A	
	Tri Clamp	04AP414213	1	04AP414219	1	N/A		04AP414231	1	N/A	
	APC-PV	04AP414214	1	04AP414220	1	N/A		04AP414232	1	N/A	
	APC-Clamp	04AP414215	1	04AP414221	1	N/A		04AP414233	1	N/A	
	APV SP (ISS)	04AP414216	1	04AP414222	1	N/A		04AP414234	1	N/A	
	CASING - 2-1/2 in. Inlet x 1-1/2 in. Outlet										
	Butt Weld	N/A		04HP414173	1	N/A		N/A		N/A	
	Bevel Seat	N/A		04AP414174	1	N/A		N/A		N/A	
	Tri Clamp	N/A		04AP414175	1	N/A		N/A		N/A	
	APC-PV	N/A		04AP414176	1	N/A		N/A		N/A	
	APC-Clamp	N/A		04AP414177	1	N/A		N/A		N/A	
	APV SP (ISS)	N/A		04AP414178	1	N/A		N/A		N/A	
1	CASING - 3 in. Inlet x 2 in. Outlet										
	Butt Weld	N/A		N/A		04HP452222	1	04AP414223	1	04HP414235	1
	Bevel Seat	N/A		N/A		04AP452331	1	04AP414224	1	04AP414236	1
	Tri Clamp	N/A		N/A		04AP452333	1	04AP414225	1	04AP414237	1
	APC-PV	N/A		N/A		04AP452332	1	04AP414226	1	04AP414238	1
	APC-Clamp	N/A		N/A		04AP452336	1	04AP414227	1	04AP414239	1
	APV SP (ISS)	N/A		N/A		04AP452335	1	04AP414228	1	04AP414240	1
	O-RING (Nitrile) (std.) (pkg of 10)	**543S131305	1	**543S131305	1	**543S131305	1	**543S131305	1	**543S131305	1
	O-RING (Viton™) (optional)	543P221154	1	543P221154	1	543P221154	1	543P221154	1	543P221154	1
	O-RING (EPDM) (optional)	543P239154	1	543P239154	1	543P239154	1	543P239154	1	543P239154	1
4	IMPELLER - Sanitary										
	2 in.	04HP342259	1	N/A		N/A		N/A		N/A	
	2-1/4 in.	04HP342258	1	N/A		N/A		N/A		N/A	
	2-1/2 in.	04HP342257	1	N/A		N/A		N/A		N/A	
	2-3/4 in.	04HP342256	1	N/A		N/A		N/A		N/A	

**Certain items are packaged in minimum quantity lots as indicated.

"V²" Series Sanitary Centrifugal Pump
Models 4V², 6V², 6VS², 8V², 8VS²

OPTIONS

ITEM	DESCRIPTION	4V ² PART NO.	QTY	6V ² PART NO.	QTY	6VS ² PART NO.	QTY	8V ² PART NO.	QTY	8VS ² PART NO.	QTY
4	IMPELLER - Sanitary	3 in.	1	N/A		N/A		N/A		N/A	
		3-1/4 in.	1	N/A		N/A		N/A		N/A	
		3-1/2 in.	1	N/A		N/A		N/A		N/A	
		3-3/4 in.	1	04HP339898	1	N/A		N/A		N/A	
		3-13/16 in.	1	N/A		N/A		N/A		N/A	
		4 in.		04HP339697	1	N/A		N/A		N/A	
		4-1/4 in.		04HP339696	1	04HP462236	1	04HP385783	1	N/A	
		4-1/2 in.		04HP339695	1	04HP452235	1	04HP385784	1	N/A	
		4-3/4 in.		04HP339694	1	04HP452234	1	04HP385785	1	04HP343883	1
		5 in.		04HP339693	1	04HP452233	1	04HP342750	1	04HP343884	1
		5-1/4 in.		04HP339692	1	04HP452232	1	04HP342749	1	04HP378596	1
		5-1/2 in.		04HP339691	1	04HP452231	1	04HP342748	1	04HP343882	1
		5-3/4 in.		N/A		N/A		N/A		N/A	
		5-13/16 in.		04HP339690	1	04HP452230	1	N/A		N/A	
		6 in.		N/A		N/A		04HP342747	1	04HP343881	1
		6-1/4 in.		N/A		N/A		04HP342746	1	04HP343880	1
		6-1/2 in.		N/A		N/A		04HP342745	1	04HP343879	1
		6-3/4 in.		N/A		N/A		04HP342744	1	04HP343878	1
		7 in.		N/A		N/A		04HP342743	1	04HP343877	1
7-1/4 in.		N/A		N/A		04HP342742	1	04HP343876	1		
7-1/2 in.		N/A		N/A		04HP342741	1	04HP343875	1		
7-13/16 in.		N/A		N/A		04HP342740	1	04HP343874	1		
5	GASKET - Beaded (Nitrile) (std.)	04HP189082	1	04HP188619	1	04HP188168	1	04HP188168	1	04HP188168	1
		04HP209368	1	04HP237713	1	04HP281188	1	04HP281188	1	04HP281188	1
		04HP419402	1	04HP419403	1	04HP408468	1	04HP408468	1	04HP408468	1
11	SHAFT - Impeller (Type 1, 2, or 5 Seal)	04AP414022	1	N/A		N/A		N/A		N/A	
		04AP414022	1	04AP414042	1	04AP414042	1	N/A		N/A	
		04AP414022	1	N/A		N/A		N/A		N/A	
		04AP414024	1	04AP414044	1	04AP414072	1	04AP414072	1	04AP414132	1
		04AP414024	1	04AP414044	1	04AP414072	1	04AP414072	1	04AP414135	1
		N/A	1	04AP414047	1	04AP414075	1	04AP414075	1	04AP414137	1
		N/A	1	04AP414049	1	04AP414077	1	04AP414077	1	04AP414137	1
		N/A	1	04AP414049	1	04AP414077	1	04AP414077	1	N/A	
		N/A	1	04AP414049	1	04AP414089	1	04AP414077	1	N/A	
		N/A	1	04AP414049	1	04AP414089	1	04AP414077	1	N/A	

"V²" Series Sanitary Centrifugal Pump
Models 4V², 6V², 6VS², 8V², 8VS²

OPTIONS

ITEM	DESCRIPTION	4V ² PART NO.	QTY	6V ² PART NO.	QTY	6VS ² PART NO.	QTY	8V ² PART NO.	QTY	8VS ² PART NO.	QTY	
11	SHAFT - Impeller					SEE 16VS2						
	254TC (1-5/8 in.)	N/A		N/A		SEE 16VS2		04AP414079	1	N/A		
	256TC (1-5/8 in.)	N/A		N/A		SEE 16VS2		04AP414079	1	04AP414139	1	
	284TSC & 286TSC (1-5/8 in.)	N/A		N/A				04AP414079	2	04AP414142	1	
	324TSC & 326TSC (1-7/8 in.)	N/A		N/A				N/A		04AP414144	1	
12	GUARD											
	M56C	N/A		04HP469330	1			N/A		N/A		
	143TC	N/A		04HP469330	1			04BP469326	1	N/A		
	145TC	N/A		04HP469330	1			04HP469336	1		1	
	182TC & 184TC	N/A		04HP469333	1			04HP469335	1		1	
	213TC	N/A		04HP469333	1			04HP469335	1		1	
	215TC	N/A		04HP469333	1			04HP469335	1		1	
	254TC	N/A		N/A				04HP469335	1	N/A		
	256TC	N/A		N/A				04HP469335	1	N/A		
	284TSC & 286TSC	N/A		N/A				04HP469335	1		1	
	324TSC & 326TSC	N/A		N/A				04HP469334	1		1	
					N/A				N/A			1
	13	ADAPTER										
M56C		N/A		04HP410288	1	N/A		N/A		N/A		
143TC		N/A		04HP410288	1	N/A		04HP410290	1	N/A		
145TC		N/A		04HP410288	1	04HP410288	1	04HP410290	1	04HP410290	1	
182TC & 184TC		N/A		04HP410287	1	04HP410287	1	04HP410291	1	04HP410291	1	
213TC		N/A		04HP410287	1	04HP410287	1	04HP410291	1	04HP410291	1	
215TC		N/A		N/A		04HP410287	1	04HP410291	1	N/A		
254TC		N/A		N/A		04HP460862	1	04HP410291	1	N/A		
256TC		N/A		N/A		04HP460862	1	04HP410291	1	04HP410291	1	
284TSC & 286TSC		N/A		N/A		04HP462228	1	04HP410370	1	04HP410370	1	
324TSC & 326TSC		N/A		N/A		N/A		N/A		04HP410371	1	
14		SLINGER - OIL										
	56C	04HP288836	1	N/A		N/A		N/A		N/A		
	M56C	04HP288836	1	04HP288836	1	N/A		N/A		N/A		
	K56C	04HP288836	1	N/A		N/A		N/A		N/A		
	143TC	04HP242591	1	04HP242591	1	N/A		04HP242591	1	N/A		
	145TC	04HP242591	1	04HP242591	1	04HP242591	1	04HP242591	1	04HP242591	1	

"V²" Series Sanitary Centrifugal Pump
 Models 4V², 6V², 8V², 10V², 12V², 15V², 18V², 20V², 25V², 30V², 35V², 40V², 45V², 50V², 55V², 60V², 65V², 70V², 75V², 80V², 85V², 90V², 95V², 100V²

OPTIONS

ITEM	DESCRIPTION	4V ² PART NO.	QTY	6V ² PART NO.	QTY	6VS ² PART NO.	QTY	8V ² PART NO.	QTY	8VS ² PART NO.	QTY	
18	SCREW - Hex Head Cap (ss)	M56C		N/A		N/A		N/A		N/A		
		143TC		N/A		N/A		521V006674	2	N/A		
		145TC		N/A		N/A		521V006674	2	N/A		
		182TC & 184TC		N/A		521V006680	2	521V006680	2	521V006674	2	
		213TC		N/A		521V006680	2	521V006680	2	521V006680	2	
		215TC		N/A		521V006680	2	521V006680	2	N/A		
		254TC		N/A		N/A		521V006686	2	N/A		
		256TC		N/A		N/A		521V006686	2	521V006696	2	
		284TSC & 286TSC		N/A		N/A		521V006696	2	521V006696	2	
		324TSC & 326TSC		N/A		N/A		N/A		521V009402	2	
		19	WASHER - Lock (ss)	M56C		N/A		N/A		N/A		N/A
143TC				N/A		N/A		523V007185	2	N/A		
145TC				N/A		523V007185	2	523V007185	2	N/A		
182TC & 184TC				N/A		523V007192	2	523V007192	2	523V007185	2	
213TC				N/A		523V007192	2	523V007192	2	523V007192	2	
215TC				N/A		523V007192	2	523V007192	2	N/A		
254TC				N/A		N/A		523V007193	2	N/A		
256TC				N/A		N/A		523V007193	2	523V007193	2	
284TSC & 286TSC				N/A		N/A		523V007193	2	523V007193	2	
324TSC & 326TSC				N/A		N/A		523V007193	2	523V007191	2	
20	WASHER - Plain (ss)			M56C		N/A		N/A		N/A		N/A
		143TC		N/A		N/A		523V007177	2	N/A		
		145TC		N/A		523V007177	2	523V007177	2	N/A		
		182TC & 184TC		N/A		523V007178	2	523V007178	2	523V007177	2	
		213TC		N/A		523V007178	2	523V007178	2	523V007178	2	
		215TC		N/A		523V007178	2	523V007178	2	N/A		
		254TC		N/A		N/A		523V007179	2	N/A		
		256TC		N/A		N/A		523V007179	2	523V007179	2	
		284TSC & 286TSC		N/A		N/A		523V007179	2	523V007179	2	
		324TSC & 326TSC		N/A		N/A		523V007179	2	523V007196	2	
		21	LEG - Rear	M56C		N/A		N/A		N/A		N/A
143TC				N/A		N/A		04HP414508	2	N/A		
145TC				N/A		04HP414508	2	04HP414508	2	04HP414508	2	
182TC & 184TC				N/A		04HP414510	2	04HP414510	2	04HP414510	2	
213TC				N/A		04HP414510	2	04HP414510	2	04HP414510	2	
215TC				N/A		04HP414510	2	04HP414510	2	N/A		

"V²" Series Sanitary Centrifugal Pump
 Models 4V², 6V², 6VS², 8V², 8VS²

OPTIONS

ITEM	DESCRIPTION	4V ² PART NO.	QTY	6V ² PART NO.	QTY	6VS ² PART NO.	QTY	8V ² PART NO.	QTY	8VS ² PART NO.	QTY	
21	LEG - Rear	N/A										
	254TC	N/A		04HP414513	2	04HP414513	2	N/A	2	N/A	2	
	256TC	N/A		04HP414513	2	04HP414513	2	04HP414513	2	04HP414513	2	
	284TSC & 286TSC	N/A		N/A		N/A		N/A		04HP419408	2	
	324TSC & 326TSC	N/A										
	SCREW - Hex Head Cap (zinc plated)											
	M56C	N/A		522V006752	4	N/A		522V006752	4	N/A	4	
143TC	N/A		522V006752	4	N/A		522V006752	4	N/A	4		
145TC	N/A		522V006752	4	522V006752	4	522V006752	4	522V006752	4		
182TC & 184TC	N/A		522V006788	4	522V006788	4	522V006788	4	522V006788	4		
213TC	N/A		522V006788	4	522V006788	4	522V006788	4	522V006788	4		
215TC	N/A		522V006788	4	522V006788	4	522V006788	4	N/A	4		
254TC	N/A		N/A		522V006788	4	522V006788	4	N/A	4		
256TC	N/A		N/A		522V006788	4	522V006788	4	522V006788	4		
284TSC & 286TSC	N/A		N/A		522V006788	4	522V006788	4	522V006788	4		
324TSC & 326TSC	N/A		N/A		N/A		N/A		522V006816	4		
24	LEG - Front											
	M56C	N/A		04HP414182	1	N/A		N/A		N/A		
	143TC	N/A		04HP414182	1	N/A		04HP414185	1	N/A		
	145TC	N/A		04HP414182	1	04HP414182	1	04HP414185	1	04HP414185	1	
	182TC & 184TC	N/A		04HP414183	1	04HP414183	1	04HP414188	1	04HP414188	1	
	213TC	N/A		04HP414184	1	04HP414184	1	04HP414187	1	04HP414187	1	
	215TC	N/A		04HP414184	1	04HP414184	1	04HP414187	1	N/A		
	254TC	N/A		N/A		04HP460943	1	04HP414188	1	N/A		
	256TC	N/A		N/A		04HP460943	1	04HP414188	1	04HP414188	1	
	284TSC & 286TSC	N/A		N/A		04HP460944	1	04HP414188	1	04HP414188	1	
	324TSC & 326TSC	N/A		N/A		N/A		N/A		04HP414188	1	
	36	SHAFT - Impeller (Type 3 or 4 Seal)										
		56C (5/8 in.)	04HP414026	1	N/A		N/A		N/A		N/A	
		M56C (5/8 in.)	04HP414026	1	04HP414051	1	N/A		N/A		N/A	
K56C (5/8 in.)		04HP414026	1	N/A		N/A		N/A		N/A		
143TC (7/8 in.)		04HP414027	1	04HP414052	1	N/A		04HP414084	1	N/A		
145TC (7/8 in.)		04HP414027	1	04HP414052	1	04HP414052	1	04HP414084	1	04HP414146	1	
182TC & 184TC (1-1/8 in.)		N/A		04HP414054	1	04HP460891	1	04HP414086	1	04HP414148	1	
213TC (1-3/8 in.)		N/A		04HP414055	1	04HP460888	1	04HP414087	1	04HP414149	1	
215TC (1-3/8 in.)		N/A		04HP414055	1	04HP460888	1	04HP414087	1	N/A		
254TC (1-5/8 in.)		N/A		N/A		04HP452224	1	04HP414088	1	N/A		
256TC (1-5/8 in.)		N/A		N/A		04HP452224	1	04HP414088	1	04HP414150	1	
284TSC & 286TSC (1-5/8 in.)		N/A		N/A		04HP452224	1	04HP414088	1	04HP414152	1	
324TSC & 326TSC (1-7/8 in.)		N/A		N/A		N/A		N/A		04HP414153	1	



"V²" Series Sanitary Centrifugal Pump
Models 4V², 6V², 6VS², 8V², 8VS²

Type 1 Seal

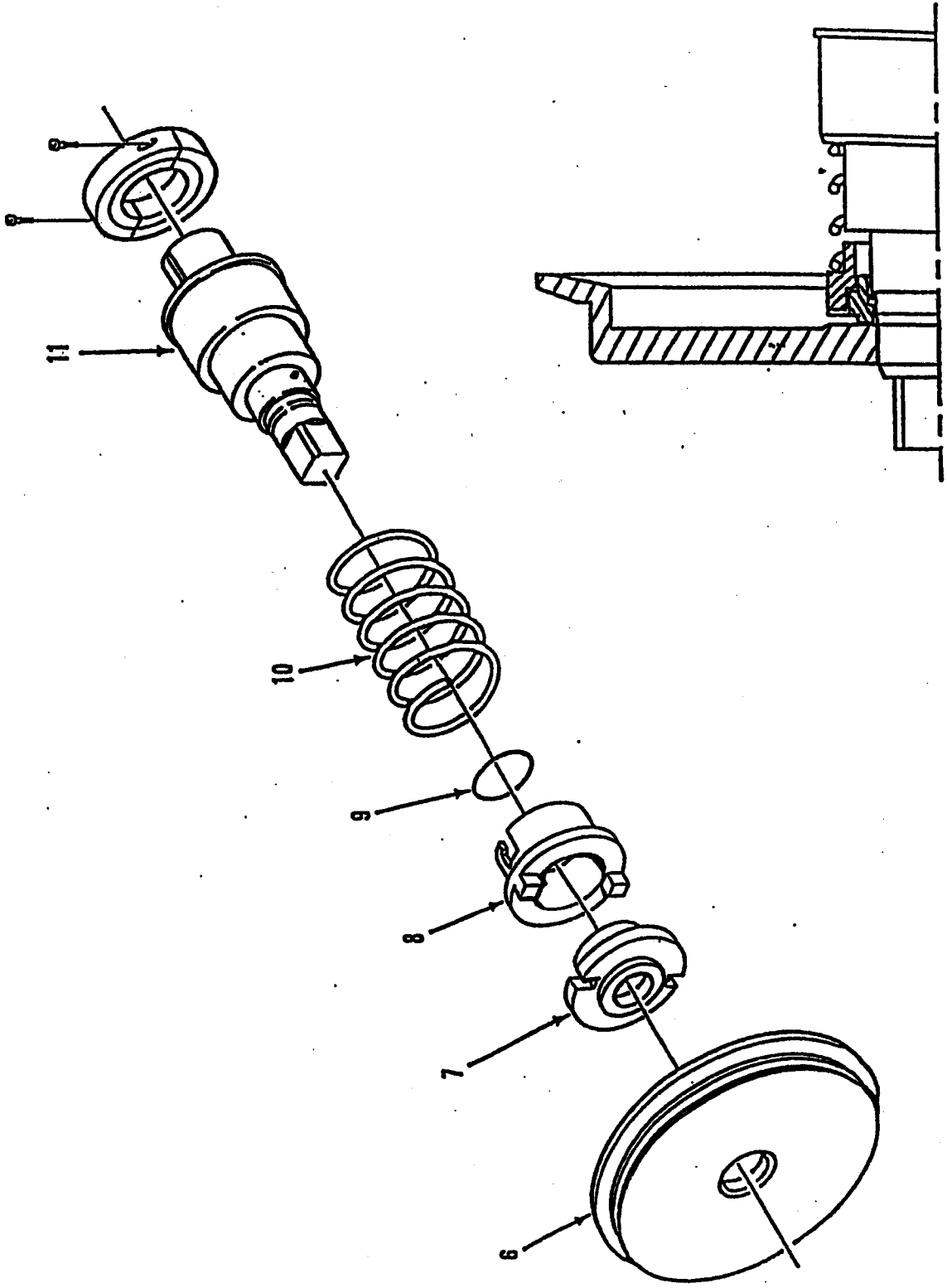

"V"² SERIES SANITARY CENTRIFUGAL PUMP
Models 4V², 6V², 6VS², 8V², 8VS²

Type 1 Seal

ITEM	DESCRIPTION	4V ² PART NO.	QTY	6V ² PART NO.	QTY	6VS ² PART NO.	QTY	8V ² PART NO.	QTY	8VS ² PART NO.	QTY
5	PLATE - Back	04HP410292	1	04HP401852	1	04HP401852	1	04HP401823	1	04HP401823	1
7	RING - Seat (carbon) (std.) RING - Seat (graphite - TFE) (optional)	546P331925 04HP357739	1 1	546P329693 04HP357740	1 1	546P329693 04HP357740	1 1	546P331198 04HP357741	1 1	546P331198 04HP357741	1 1
8	RING - Drive	04HP342268	1	04HP339763	1	04HP339763	1	727P331199	1	727P331199	1
9	O-RING (Nitrile) (std.) (pkg of 10) O-RING (Viton™) (optional) O-RING (EPDM) (optional)	**543S131315 543P221164 543P239164	1 1 1	**543S131320 543P221169 543P239169	1 1 1	**543S131320 543P221169 543P239169	1 1 1	**543S131324 543P221173 543P239173	1 1 1	**543S131324 543P221173 543P239173	1 1 1
10	SPRING	622P304634	1	622P339833	1	622P339833	1	622P342823	1	622P342823	1
11	SHAFT - Impeller	*		*		*		*		*	

*See the Pump Options section for customer option.
 **Certain items are packaged in minimum quantity lots as indicated.

"V" Series Sanitary Centrifugal Pump
Models 4V², 6V², 6VS², 8V², 8VS²

Type 2 Seal

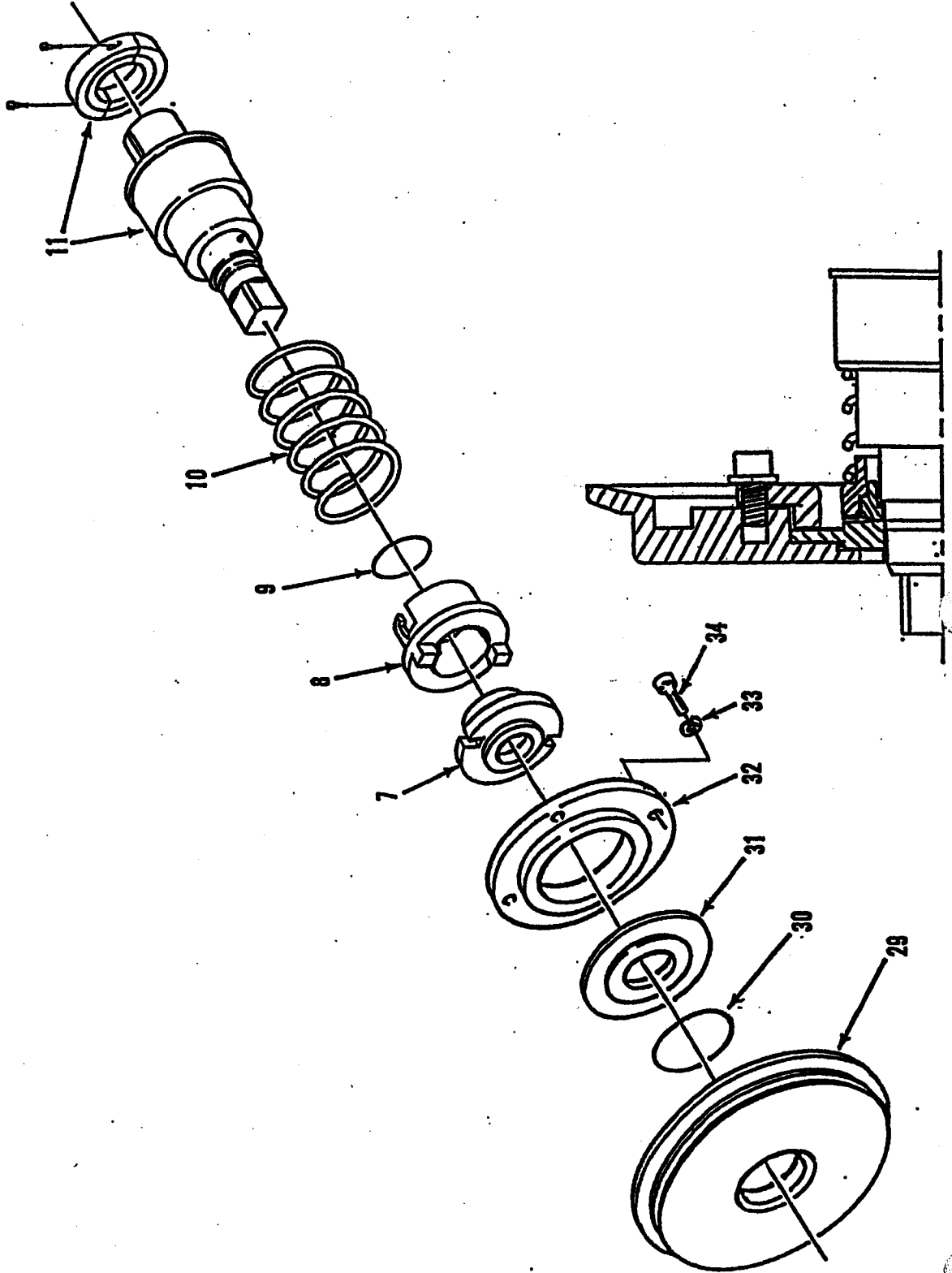

"V²" Series Sanitary Centrifugal Pump
 Models 4V², 6V², 8VS², 8V², 8VS²

Type 2 Seal

ITEM	DESCRIPTION	4V ² PART NO.	QTY	6V ² PART NO.	QTY	6VS ² PART NO.	QTY	8V ² PART NO.	QTY	8VS ² PART NO.	QTY
7	RING - Seat (carbon) (std.)	548P331925	1	548P328693	1	548P328693	1	548P331198	1	546P331198	1
	RING - Seat (graphite - TFE) (optional)	04HP357739	1	04HP357740	1	04HP357740	1	04HP357741	1	04HP357741	1
	RING - Seat (siliconized carbon) (optional)	***548P410943	1	***546P365566	1	***548P365566	1	***546P365567	1	***546P365567	1
8	RING - Drive	04HP342268	1	04HP339763	1	04HP339763	1	04HP342562	1	04HP342562	1
9	O-RING (Nitrile) (std.) (pkg of 10)	**543S131315	1	**543S131320	1	**543S131320	1	**543S131324	1	**543S131324	1
	O-RING (Viton™) (optional)	543P221164	1	543P221169	1	543P221169	1	543P221173	1	543P221173	1
	O-RING (EPDM) (optional)	543P239164	1	543P239169	1	543P239169	1	543P239173	1	543P239173	1
10	SPRING	622P304634	1	622P339834	1	622P339833	1	622P342824	1	622P342824	1
11	SHAFT - Impeller										
29	PLATE - Back	04HP410278	1	04HP410284	1	04HP410284	1	04HP410289	1	04HP410289	1
30	O-RING (Nitrile) (std.) (pkg of 10)	**543S1313CQ	1	**543S1313CV	1	**543S1313CV	1	**543S1313DD	1	**543S1313DD	1
	O-RING (Viton™) (optional)	543P319682	1	543P319687	1	543P319687	1	543P319675	1	543P319675	1
	O-RING (EPDM) (optional)	543SK24128	1	543SK24133	1	543SK24133	1	543SK24141	1	543SK24141	1
31	INSERT - Seal (ss) (std.)	04HP421761	1	04HP421762	1	04HP421762	1	04HP421763	1	04HP421763	1
	INSERT - Seal (silicon carbide) (optional)	546P436617	1	546P436618	1	546P436618	1	546P436619	1	546P436619	1
32	RING - Insert Holder	04HP410616	1	04HP410616	1	04HP410616	1	04HP410617	1	04HP410617	1
33	WASHER - Lock (ss) (pkg of 10)	**523V007189	4	**523V007190	4	**523V007190	4	**523V007190	4	**523V007190	4
34	SCREW - Socket Head Cap (ss)	521V006692	4	521V020366	4	521V020366	4	521V020366	4	521V020366	4

*See the pump Options section for customer option.
 **Certain items are packaged in minimum quantity lots as indicated.
 ***Use siliconized carbon seat ring only with silicon carbide seal insert.

1 1/2" Series Sanitary Centrifugal Pump
Models 4V², 6V², 6VS², 8V², 8VS²

Type 3 Seal

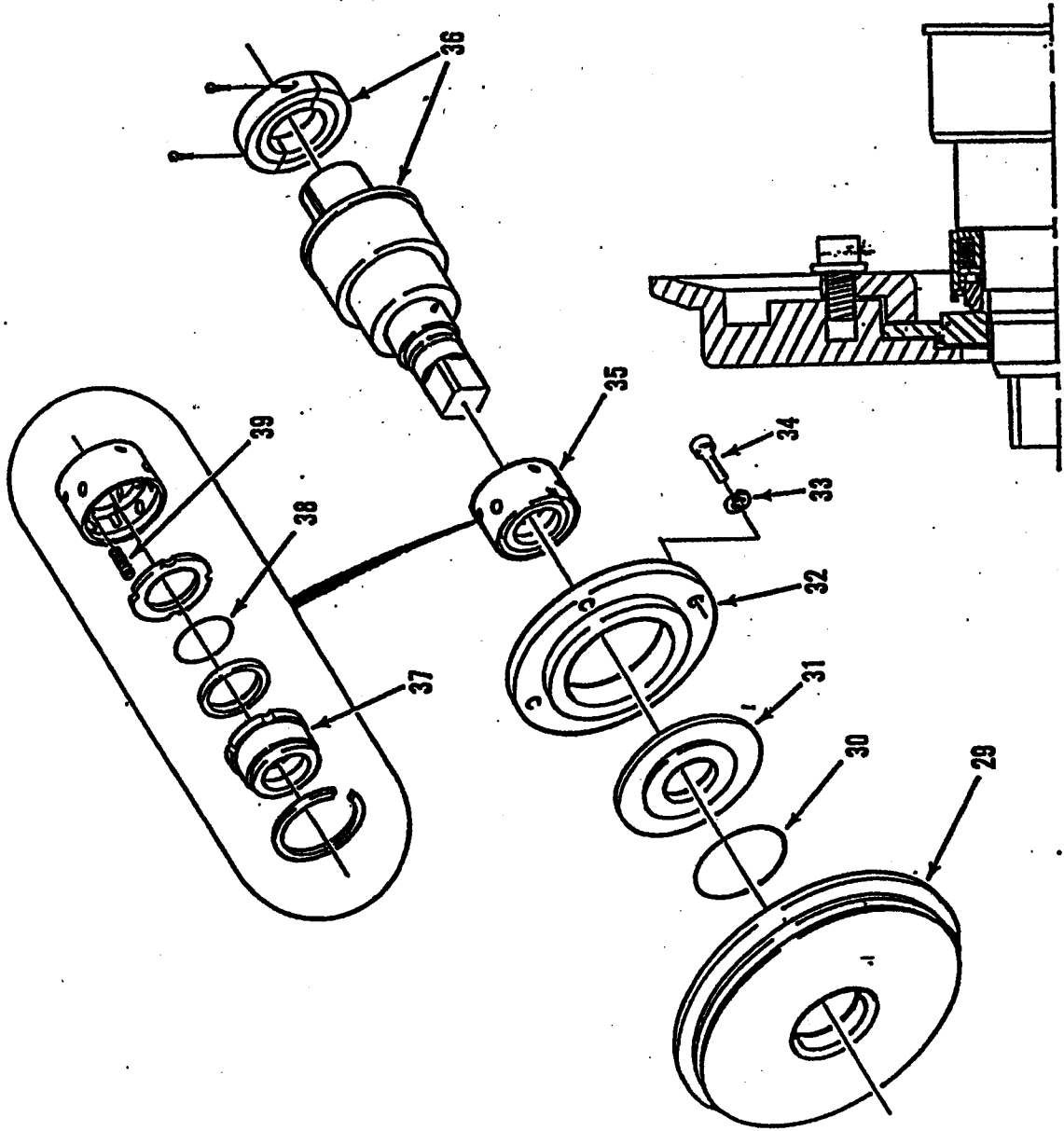

"V²" Series Sanitary Centrifugal Pump
Models 4V², 6V², 6VS², 8V², 8VS²

Type 3 Seal

ITEM	DESCRIPTION	4V ² PART NO.	QTY	6V ² PART NO.	QTY	6VS ² PART NO.	QTY	8V ² PART NO.	QTY	8VS ² PART NO.	QTY
29	PLATE - Back	04HP410278	1	04HP410284	1	04HP410284	1	04HP410289	1	04HP410289	1
30	O-RING (Nitrile) (std.) (pkg of 10)	**643S1313CQ	1	**643S1313CV	1	**643S1313CV	1	**643S1313DD	1	**643S1313DD	1
	O-RING (Viton™) (optional)	643P319662	1	643P319667	1	643P319667	1	643P319675	1	643P319675	1
	O-RING (EPDM) (optional)	643SK24128	1	643SK24133	1	643SK24133	1	643SK24141	1	643SK24141	1
31	INSERT - Seal (ss) (std.)	04HP421751	1	04HP421752	1	04HP421752	1	04HP421753	1	04HP421753	1
	INSERT - Seal (silicon carbide) (optional)	646P436617	1	646P436618	1	646P436618	1	646P436619	1	646P436619	1
32	RING - Insert Holder	04HP410615	1	04HP410616	1	04HP410616	1	04HP410617	1	04HP410617	1
33	WASHER - Lock (ss) (pkg of 10)	**623V007189	4	**623V007190	4	**623V007190	4	**623V007190	4	**623V007190	4
34	SCREW - Socket Head Cap (ss)	621V006692	4	621V020366	4	621V020366	4	621V020366	4	621V020366	4
35	SEAL - Mechanical (John Crane™)	649SK376A	1	649SK376B	1	649SK376B	1	649SK376C	1	649SK376C	1
36	SHAFT - Impeller										
37	SEAL - Carbon	649SK377A	1	649SK377B	1	649SK377B	1	649SK377C	1	649SK377C	1
38	O-RING (Nitrile) (std.) (pkg of 10)	**643S131317	1	**643S131323	1	**643S131323	1	**643S131327	1	**643S131327	1
	O-RING (Viton™) (optional)	643P221166	1	643P221172	1	643P221172	1	643P221176	1	643P221176	1
	O-RING (EPDM) (optional)	643P239116	1	643P239172	1	643P239172	1	643P239176	1	643P239176	1
39	SPRING (pkg of 10)	**622SK579A	6	**622SK579D	6	**622SK579D	6	**622SK579D	6	**622SK579D	6

*See the pump Options section for customer option.
**Certain items are packaged in minimum quantity lots as indicated.

"V²" Series Sanitary Centrifugal Pump
Models 4V², 6V², 6VS², 8V², 8VS²

Type 4 Seal

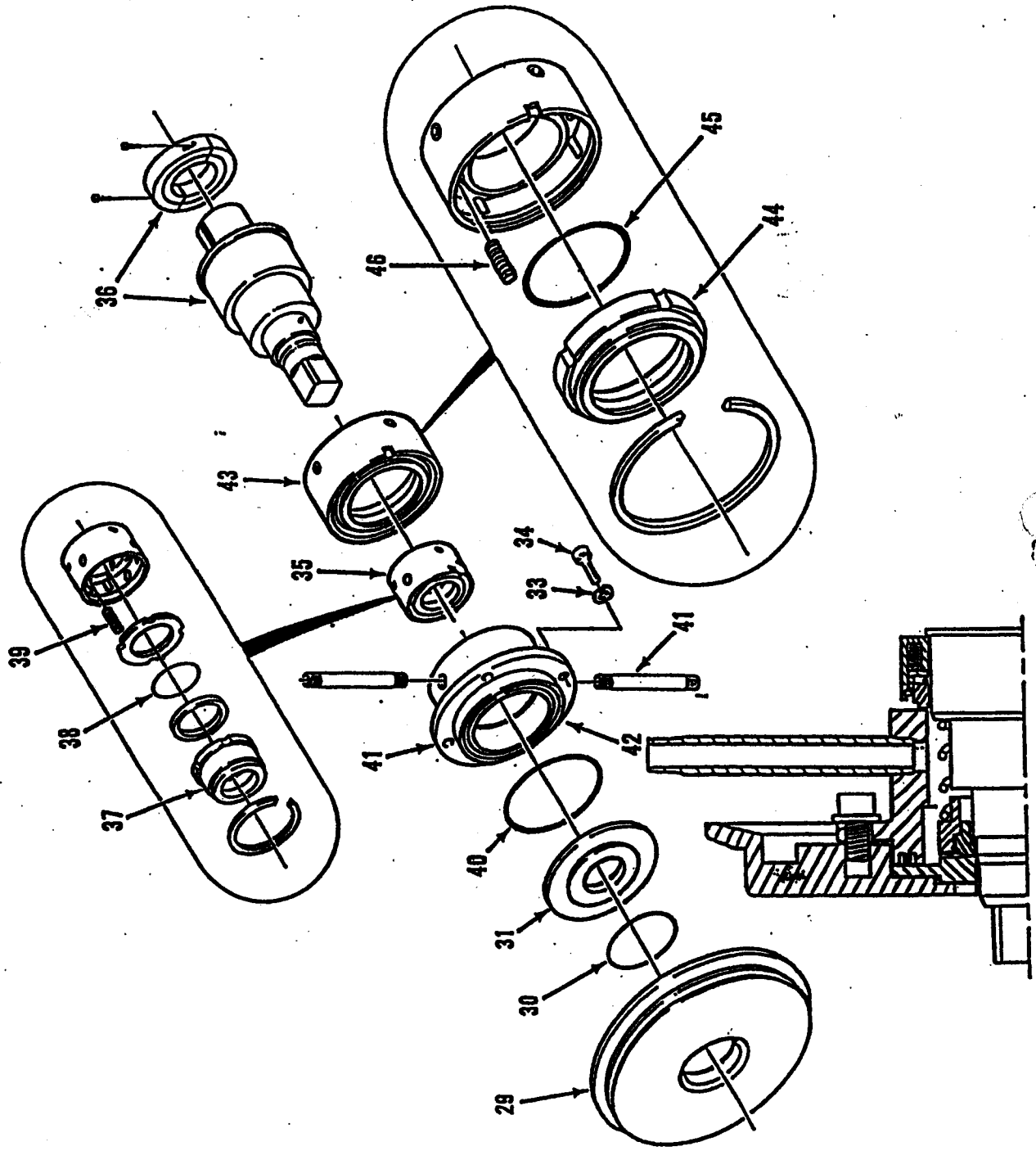

"V²" Series Sanitary Centrifugal Pump
Models 4V², 6V², 6VS², 8V², 8VS²

Type 4 Seal

ITEM	DESCRIPTION	4V ² PART NO.	QTY	6V ² PART NO.	QTY	6VS ² PART NO.	QTY	8V ² PART NO.	QTY	8VS ² PART NO.	QTY
29	PLATE - Back	04HP410278	1	04HP410284	1	04HP410284	1	04HP410289	1	04HP410289	1
30	O-RING (Nitrile) (std.) (pkg of 10)	**543S1313CQ	1	**543S1313CV	1	**543S1313CV	1	**543S1313DD	1	**543S1313DD	1
	O-RING (Viton™) (optional)	543P319662	1	543P319667	1	543P319667	1	543P319675	1	543P319675	1
	O-RING (EPDM) (optional)	543SK24128	1	543SK24133	1	543SK24133	1	543SK24141	1	543SK24141	1
31	INSERT - Seal (ss) (std.)	04HP421751	1	04HP421752	1	04HP421752	1	04HP421753	1	04HP421753	1
	INSERT - Seal (silicon carbide) (optional)	546P436617	1	546P436618	1	546P436618	1	546P436619	1	546P436619	1
33	WASHER - Lock (ss) (pkg of 10)	**623V007189	4	**623V007190	4	**623V007190	4	**623V007190	4	**623V007190	4
34	SCREW - Socket Head Cap (ss)	621V008892	4	621V020366	4	621V020366	4	621V020366	4	621V020366	4
35	SEAL - Mechanical (John Crane™)	549SK376A	1	549SK376B	1	549SK376B	1	549SK376C	1	549SK376C	1
36	SHAFT - Impeller										
37	SEAL (carbon)	549SK377A	1	549SK377B	1	549SK377B	1	549SK377C	1	549SK377C	1
38	O-RING (Nitrile) (std.) (pkg of 10)	**543S131212	1	**543S131218	1	**543S131223	1	**543S131222	1	**543S131222	1
	O-RING (Viton™) (optional)	543P221166	1	543P221172	1	543P221172	1	543P221176	1	543P221176	1
	O-RING (EPDM) (optional)	543P239166	1	543P239172	1	543P239172	1	543P239176	1	543P239176	1
39	SPRING (pkg of 10)	**622SK579A	6	**622SK579D	6	**622SK579D	6	**622SK579D	6	**622SK579D	6
40	O-RING (Nitrile) (std.) (pkg of 10)	**543S1313CZ	1	**543S131407	1	**543S131407	1	**543S131410	1	**543S131410	1
	O-RING (Viton™) (optional)	543P319671	1	543P284707	1	543P284707	1	543P284710	1	543P284710	1
	O-RING (EPDM) (optional)	543SK24137	1	543P239334	1	543P239334	1	543P239337	1	543P239337	1
41	NIPPLE	567V006089	2	567V005511	2	567V005511	2	567V020611	2	567V020611	2
42	CHAMBER - Water Seal	04HP421754	1	04HP421765	1	04HP421765	1	04HP421766	1	04HP421766	1
	Stainless Steel (std.)	04HP416336	1	04HP416337	1	04HP416337	1	04HP416338	1	04HP416338	1
	Chrome Oxide, Coated (optional)	549SK378A	1	549SK378B	1	549SK378B	1	549SK378C	1	549SK378C	1
43	SEAL - Mechanical (John Crane™)	549SK379A	1	549SK379B	1	549SK379B	1	549SK379C	1	549SK379C	1
44	SEAL - Carbon	**543S131402	1	**543S131404	1	**543S131404	1	**543S131408	1	**543S131408	1
	O-RING (Nitrile) (std.) (pkg. 10)	543P284702	1	543P284704	1	543P284704	1	543P284708	1	543P284708	1
	O-RING (Viton™) (optional)	543P239329	1	543P239331	1	543P239331	1	543P239335	1	543P239335	1
	O-RING (EPDM) (optional)	**622SK579B	4	**622SK579C	6	**622SK579C	6	**622SK579D	4	**622SK579D	4

*See the pump Options section for customer option.
**Certain items are packaged in minimum quantity lots as indicated.

1 1/2" Series Sanitary Centrifugal Pump
Models 4V², 6V², 6VS², 8V², 8VS²

Type 5 Seal

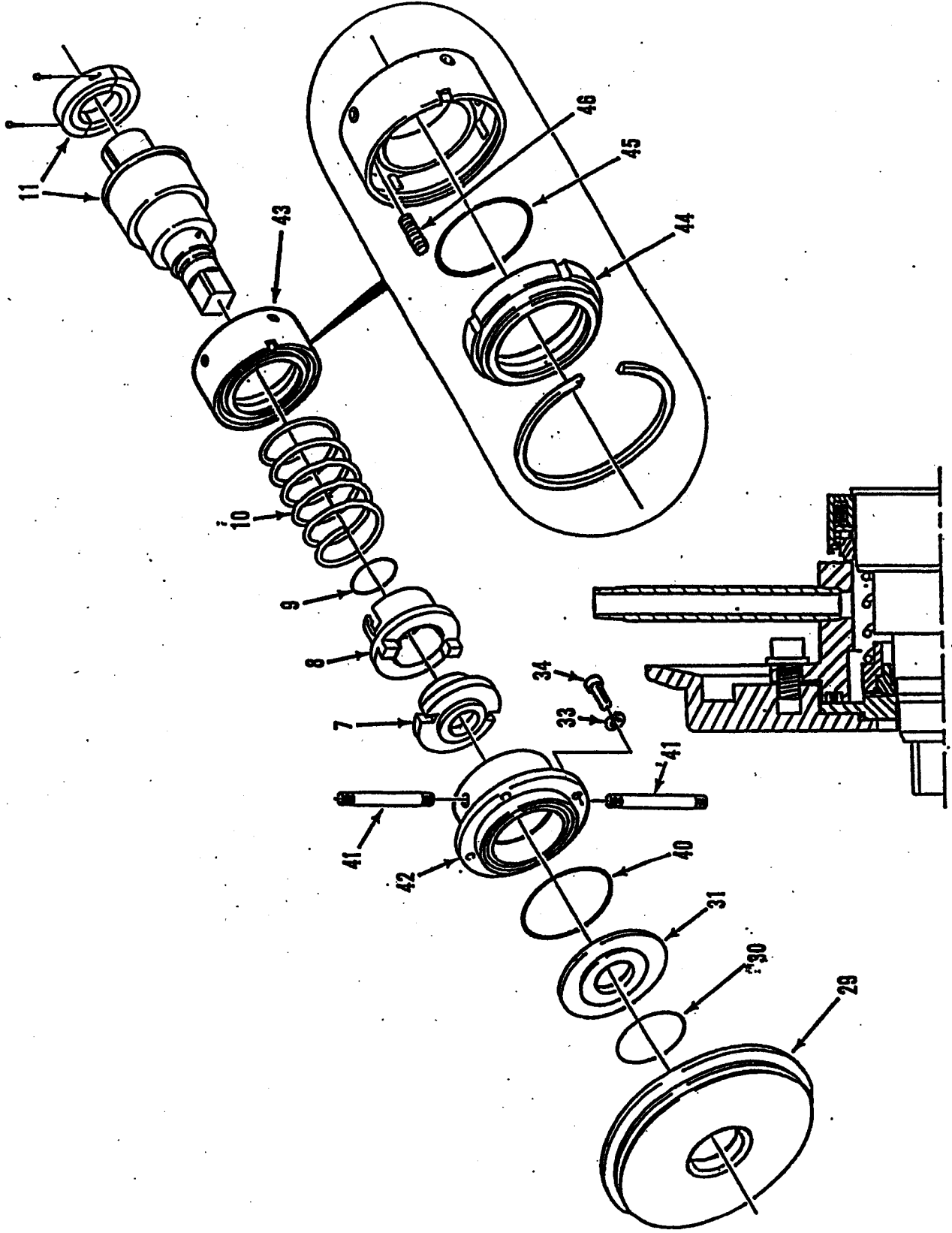

"V²" Series Sanitary Centrifugal Pump
Models 4V², 6V², 8V², 8VS², 8V², 8VS²

Type 5 Seal

ITEM DESCRIPTION	4V ² PART NO.	QTY	6V ² PART NO.	QTY	6VS ² PART NO.	QTY	8V ² PART NO.	QTY	8VS ² PART NO.	QTY
RING - Seal (carbon) (std.)	546P331925	1	546P329693	1	546P329693	1	546P331198	1	546P331198	1
RING - Seal (graphite - TFE) (optional)	04HP357739	1	04HP357740	1	04HP357740	1	04HP357741	1	04HP357741	1
RING - Seal (silicized carbon) (optional)	***546P410943	1	***546P355586	1	***546P355586	1	***546P355587	1	***546P355587	1
RING - Drive	04HP342268	1	04HP339763	1	04HP339763	1	04HP342562	1	04HP342562	1
O-RING (Nitrile) (std.) (pkg of 10)	**543S131320	1	**543S131320	1	**543S131320	1	**543S131324	1	**543S131324	1
O-RING (Viton™) (optional)	543P221164	1	543P221169	1	543P221169	1	543P221173	1	543P221173	1
O-RING (EPDM) (optional)	543P239164	1	543P239169	1	543P239169	1	543P239173	1	543P239173	1
SPRING	622P304634	1	622P339834	1	622P339833	1	622P342824	1	622P342824	1
SHAFT - Impeller	04HP410278	1	04HP410284	1	04HP410284	1	04HP410289	1	04HP410289	1
PLATE - Back	**543S1313CQ	1	**543S1313CV	1	**543S1313CV	1	**543S1313DD	1	**543S1313DD	1
O-RING (Nitrile) (std.) (pkg of 10)	543P319662	1	543P319667	1	543P319667	1	543P319676	1	543P319676	1
O-RING (Viton™) (optional)	543SK241-28	1	543SK24133	1	543SK24133	1	543SK24141	1	543SK24141	1
O-RING (EPDM) (optional)	04HP421751	1	04HP421762	1	04HP421762	1	04HP421763	1	04HP421763	1
INSERT - Seal (ss) (std.)	546P436617	1	546P436618	1	546P436618	1	546P436619	1	546P436619	1
INSERT - Seal (silicon carbide) (optional)	**523V007189	4	**523V007190	4	**523V007190	4	**523V007190	4	**523V007190	4
WASHER - Lock (ss) (pkg of 10)	521V006682	4	521V020366	4	521V020366	4	521V020366	4	521V020366	4
SCREW - Socket Head Cap (ss)	**543S1313CZ	1	**543S131407	1	**543S131407	1	**543S131410	1	**543S131410	1
O-RING (Nitrile) (std.) (pkg of 10)	543P319671	1	543P284707	1	543P284707	1	543P284710	1	543P284710	1
O-RING (Viton™) (optional)	543SK24137	1	543P239337	1	543P239337	1	543P239337	1	543P239337	1
O-RING (EPDM) (optional)	567V006089	2	567V005611	2	567V005611	2	567V020611	2	567V020611	2
NIPPLE	04HP421764	1	04HP421765	1	04HP421765	1	04HP421766	1	04HP421766	1
CHAMBER - Water Seal	04HP416338	1	04HP416337	1	04HP416337	1	04HP416338	1	04HP416338	1
Stainless Steel (std.)										
Chrome Oxide, Coated (optional)										

* See the pump Options section for customer option.
** Certain items are packaged in minimum quantity lots as indicated.
*** Use silicized carbon seat ring only with silicon carbide seal insert.

"V²" Series Sanitary Centrifugal Pump
 Models 4V², 6V², 6VS², 8V², 8VS²

Type 5 Seal

ITEM	DESCRIPTION	4V ² PART NO.	QTY	6V ² PART NO.	QTY	6VS ² PART NO.	QTY	8V ² PART NO.	QTY	8VS ² PART NO.	QTY
43	SEAL - Mechanical (John Crane™)	549SK378A	1	549SK378B	1	549SK378B	1	549SK378C	1	549SK378C	1
44	SEAL - Carbon	**549SK379A	1	**549SK379B	1	**549SK379B	1	**549SK379C	1	**549SK379C	1
45	O-RING (Nitrile) (std.) (pkg of 10)	**643S131402	1	**643S131404	1	**643S131404	1	**643S131408	1	**643S131408	1
	O-RING (Viton™) (optional)	643P284702	1	643P284704	1	643P284704	1	643P284708	1	643P284708	1
	O-RING (EPDM) (optional)	643P239329	1	643P239331	1	643P239331	1	643P239335	1	643P239335	1
46	SPRING - (pkg of 10)	**622SK579B	4	**622SK579C	6	**622SK579C	6	**622SK579D	4	**622SK579D	4

*See the pump Options section for customer option.
 **Certain items are packaged in minimum quantity lots as indicated.
 ...Use siliconized carbon seat ring only with silicon carbide seal insert.

1/2" Series Industrial Centrifugal Pump
Models 14V², 16V², 16VS², 18V², 18VS²

STANDARD

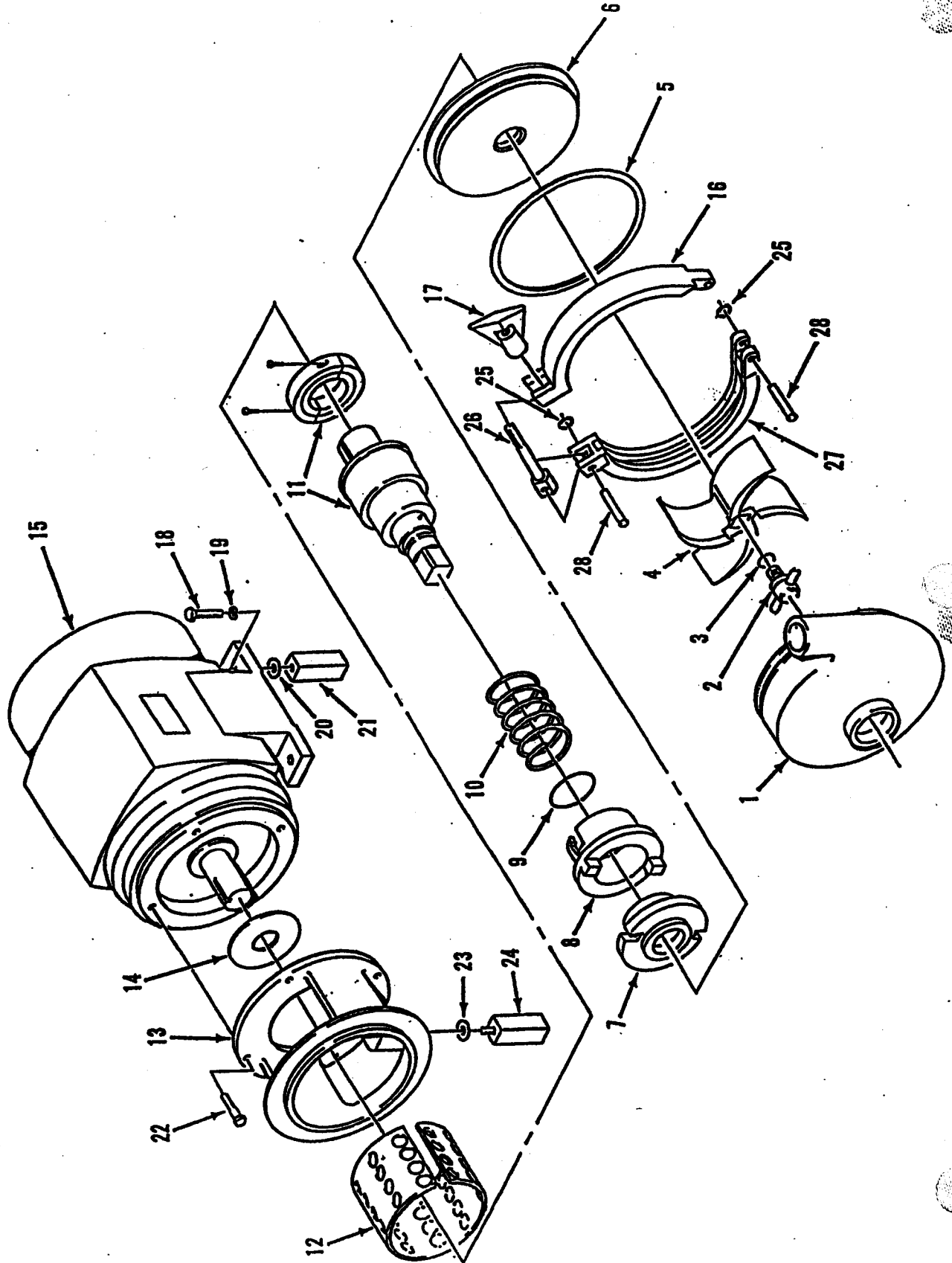

"V²" Series Industrial Centrifugal Pump
Models 14V², 16V², 18V², 18VS²

STANDARD

ITEM	DESCRIPTION	14V ² PART NO.	QTY	16V ² PART NO.	QTY	16VS ² PART NO.	QTY	18V ² PART NO.	QTY	18VS ² PART NO.	QTY
1	CASING - Industrial Pump	"04HP414241 727P411442	1	"04HP414249 727P411443	1	"04XP452330 727P411443	1	"04AP414257 727P411443	1	"04HP414265 727P411443	1
2	PIN	"543S131305	1	"543S131305	1	"543S131305	1	"543S131305	1	"04HP356777	1
3	O-RING	"04HP346845	1	"04HP356516	1	"04XP452229	1	"04HP356706	1	"04HP188168	1
4	IMPELLER - Industrial (full length)	"04HP189082	1	"04HP189619	1	"	1	"	1	"	1
5	GASKET - Beaded	"	1	"	1	"	1	"	1	"	1
11	SHAFT - Impeller	"	1	"	1	"	1	"	1	"	1
12	GUARD	"	1	"	1	"	1	"	1	"	1
13	ADAPTER	"	1	"	1	"	1	"	1	"	1
14	SLINGER - Oil	"	1	"	1	"	1	"	1	"	1
15	MOTOR (see MOTOR note below)	N/A	1	N/A	1	N/A	1	N/A	1	N/A	1
16	RING - Clamp	727P342248 727P339252	1	727P339707 727P339252	1	727P339707 727P339252	1	727P342760 727P339252	1	727P342760 727P339252	1
17	NUT - Wing	"	1	"	1	"	1	"	1	"	1
18	(see OPTION Item #49)	"	1	"	1	"	1	"	1	"	1
19	(see OPTION Item #49)	"	1	"	1	"	1	"	1	"	1
20	(see OPTION Item #49)	"	1	"	1	"	1	"	1	"	1
21	(see OPTION Item #49)	"	1	"	1	"	1	"	1	"	1
22	SCREW - Hex Head Cap (zinc plated)	"	1	"	1	"	1	"	1	"	1
23	(see OPTION Item #49)	"	1	"	1	"	1	"	1	"	1
24	(see OPTION Item #49)	"	1	"	1	"	1	"	1	"	1
25	RING - Lock (pkg of 10)	"	1	"	1	"	1	"	1	"	1
26	PIN - Pivot	"	1	"	1	"	1	"	1	"	1
27	RING - Clamp	"	1	"	1	"	1	"	1	"	1
28	PIN (pkg of 10)	"	1	"	1	"	1	"	1	"	1

MOTOR: When ordering a motor or motor parts, specify the complete motor nameplate information.

*See the pump Options section for customer option.

**Certain items are packaged in minimum quantity lots as indicated.

"V²" Series Industrial Centrifugal Pump
 Models 14V², 16V², 16VS², 18V², 18VS²

OPTIONS

ITEM	DESCRIPTION	14V ² PART NO.	QTY	16V ² PART NO.	QTY	16VS ² PART NO.	QTY	18V ² PART NO.	QTY	18VS ² PART NO.	QTY
1	CASING - 1-1/2 In. Inlet x 1 1-1/2 Outlet										
	Butt Weld	04HP414241	1	N/A		N/A		N/A		N/A	
	Bevel Seat	04AP414242	1	N/A		N/A		N/A		N/A	
	Tri Clamp	04AP414243	1	N/A		N/A		N/A		N/A	
	APC-PV	04AP414244	1	N/A		N/A		N/A		N/A	
	APC Clamp	04AP414245	1	N/A		N/A		N/A		N/A	
	APV SP (ISS)	04AP414246	1	N/A		N/A		N/A		N/A	
	Pipe Thread	04AP414247	1	N/A		N/A		N/A		N/A	
	Flange	04AP414248	1	N/A		N/A		N/A		N/A	
	CASING - 2 In. Inlet x 1-1/2 In. Outlet										
1	Butt Weld	N/A		04HP414249	1	N/A		N/A		N/A	
	Bevel Seat	N/A		04AP414250	1	N/A		N/A		N/A	
	Tri Clamp	N/A		04AP414251	1	N/A		N/A		N/A	
	APC-PV	N/A		04AP414252	1	N/A		N/A		N/A	
	APC Clamp	N/A		04AP414253	1	N/A		N/A		N/A	
	APV SP (ISS)	N/A		04AP414254	1	N/A		N/A		N/A	
	Pipe Thread	N/A		04AP414255	1	N/A		N/A		N/A	
	Flange	N/A		04AP414256	1	N/A		N/A		N/A	
	CASING - 2-1/2 In. Inlet x 1-1/2 In. Outlet										
	1	Butt Weld	N/A		04HP414992	1	N/A		N/A		N/A
Bevel Seat		N/A		04AP414993	1	N/A		N/A		N/A	
Tri Clamp		N/A		04AP414994	1	N/A		N/A		N/A	
APC-PV		N/A		04AP414995	1	N/A		N/A		N/A	
APC Clamp		N/A		04AP414996	1	N/A		N/A		N/A	
APV SP (ISS)		N/A		04AP414997	1	N/A		N/A		N/A	
Pipe Thread		N/A		04AP414998	1	N/A		N/A		N/A	
Flange		N/A		04AP414999	1	N/A		N/A		N/A	
CASING - 3 In. Inlet x 2 In. Outlet											
1		Butt Weld	N/A		N/A		04HP452338	1	04AP414257	1	04HP414265
	Bevel Seat	N/A		N/A		04HP452339	1	04AP414258	1	04AP414266	1
	Tri Clamp	N/A		N/A		04HP452341	1	04AP414259	1	04AP414267	1
	APC-PV	N/A		N/A		04HP452340	1	04AP414280	1	04AP414288	1
	APC Clamp	N/A		N/A		04HP452344	1	04AP414281	1	04AP414269	1
	APV SP (ISS)	N/A		N/A		04HP452343	1	04AP414262	1	04AP414270	1
	Pipe Thread	N/A		N/A		04HP452346	1	04AP414263	1	04AP414271	1
	Flange	N/A		N/A		04HP452348	1	04AP414264	1	04AP414272	1

"V²" SERIES INDUSTRIAL CENTRIFUGAL PUMP
Models 14V², 16V², 16VS², 18V², 18VS²

OPTIONS

ITEM	DESCRIPTION	14V ² PART NO.	QTY	16V ² PART NO.	QTY	16VS ² PART NO.	QTY	18V ² PART NO.	QTY	18VS ² PART NO.	QTY
3	O-RING (Nitrile) (std.) (pkg of 10)	**543S131305	1	**543S131305	1	**543S131305	1	**543S131305	1	**543S131305	1
	O-RING (Viton™) (optional)	543P221154	1	543P221154	1	543P221154	1	543P221154	1	543P221154	1
	O-RING (EPDM) (optional)	543P239154	1	543P239154	1	543P239154	1	543P239154	1	543P239154	1
4	IMPELLER - Industrial										
	2-1/2 in.	04HP356850	1	N/A		N/A		N/A		N/A	
	2-3/4 in.	04HP356849	1	N/A		N/A		N/A		N/A	
	3 in.	04HP356848	1	N/A		N/A		N/A		N/A	
	3-1/4 in.	04HP356847	1	04HP393287	1	N/A		N/A		N/A	
	3-1/2 in.	04HP356846	1	04HP356524	1	N/A		N/A		N/A	
	3-3/4 in.	N/A		04HP356525	1	N/A		N/A		N/A	
	3-13/16 in.	04HP3456845	1	N/A		N/A		N/A		N/A	
	4 in.	N/A		04HP356523	1	N/A		N/A		N/A	
	4-1/4 in.	N/A		04HP356522	1	04HP452244	1	N/A		N/A	
	4-1/2 in.	N/A		04HP356521	1	04HP452243	1	N/A		N/A	
	4-3/4 in.	N/A		04HP245420	1	04HP452242	1	N/A		N/A	
	5 in.	N/A		04HP356519	1	04HP452241	1	04HP356719	1	N/A	
	5-1/4 in.	N/A		04HP356518	1	04HP452240	1	04HP356718	1	N/A	
	5-1/2 in.	N/A		04HP356517	1	04HP452239	1	04HP356717	1	N/A	
	5-3/4 in.	N/A		N/A		N/A		04HP356716	1	04HP356785	1
	5-13/16 in.	N/A		04HP356516	1	04HP452238	1	N/A		N/A	
	6 in.	N/A		N/A		N/A		04HP356715	1	04HP356784	1
	6-1/4 in.	N/A		N/A		N/A		04HP356714	1	04HP356783	1
	6-1/2 in.	N/A		N/A		N/A		04HP356713	1	04HP356782	1
6-3/4 in.	N/A		N/A		N/A		04HP356712	1	04HP356781	1	
7 in.	N/A		N/A		N/A		04HP356711	1	04HP356780	1	
7-1/4 in.	N/A		N/A		N/A		04HP356710	1	04HP356779	1	
7-1/2 in.	N/A		N/A		N/A		04HP356709	1	04HP356778	1	
7-13/16 in.	N/A		N/A		N/A		04HP356708	1	04HP356777	1	
5	GASKET - Braided (Nitrile) (std.)	04HP189082	1	04HP189619	1	04HP189619	1	04HP189168	1	04HP189168	1
	GASKET (Viton™) (optional)	04HP209368	1	04HP237713	1	04HP237713	1	04HP261188	1	04HP261188	1
	GASKET (EPDM) (optional)	04HP419402	1	04HP419403	1	04HP419403	1	04HP408466	1	04HP408466	1

*See the Pump Options section for customer option.
 **Certain items are packaged in minimum quantity lots as indicated.

"V"² SERIES INDUSTRIAL CENTRIFUGAL PUMP
Models 14V², 16V², 16VS², 18V², 18VS²

OPTIONS

ITEM	DESCRIPTION	14V ² PART NO.	QTY	16V ² PART NO.	QTY	16VS ² PART NO.	QTY	18V ² PART NO.	QTY	18VS ² PART NO.	QTY	
11	SHAFT - Impeller (Type 1, 2 or 5 seal)											
	586C (5/8 in.)	04AP414022	1	N/A		04AP414042	1	N/A		N/A		
	M56C (5/8 in.)	04AP414022	1	04AP414042	1	N/A		N/A		N/A		
	K56C (5/8 in.)	04AP414022	1	N/A		N/A		N/A		N/A		
	143TC (7/8 in.)	04AP414024	1	04AP414044	1	04AP414044	1	04AP414072	1	N/A		
	145TC (7/8 in.)	04AP414024	1	04AP414044	1	04AP414044	1	04AP414072	1	04AP414132	1	
	182TC & 184TC (1-1/8 in.)	04AP414024	1	04AP414047	1	04AP414047	1	04AP414075	1	04AP414135	1	
	182TC (1-3/8 in.)	N/A		04AP414049	1	04AP414049	1	04AP414077	1	04AP414137	1	
	213TC (1-3/8 in.)	N/A		04AP414049	1	04AP414049	1	04AP414077	1	N/A		
	215TC (1-3/8 in.)	N/A		N/A		04AP460859	1	04AP414079	1	N/A		
	254TC (1-5/8 in.)	N/A		N/A		04AP460859	1	04AP414079	1	04AP414139	1	
	256TC (1-5/8 in.)	N/A		N/A		04AP460859	1	04AP411986	1	04AP414142	1	
	284TSC & 286TSC (1-5/8 in.)	N/A		N/A		04AP460859	1	04AP411986	1	04AP414142	1	
	324TSC & 326TSC (1-7/8 in.)	N/A		N/A		N/A		N/A		04AP414144	1	
	12	GUARD										
M56C		N/A		04HP469330	1	04HP469330	1	N/A		N/A		
143TC		N/A		04HP469330	1	04HP469330	1	04HP469336	1	N/A		
145TC		N/A		04HP469330	1	04HP469330	1	04HP469336	1	04HP469336	1	
182TC & 184TC		N/A		04HP469333	1	04HP469333	1	04HP469335	1	04HP469335	1	
213TC		N/A		04HP469333	1	04HP469333	1	04HP469335	1	04HP469335	1	
215TC		N/A		04HP469333	1	04HP469333	1	04HP469335	1	N/A		
254TC		N/A		N/A		04HP469331	1	04HP469335	1	N/A		
256TC		N/A		N/A		04HP469331	1	04HP469335	1	04HP469335	1	
284TSC & 286TSC		N/A		N/A		04HP469331	1	04HP469335	1	04HP469335	1	
324TSC & 326TSC		N/A		N/A		04HP469331	1	04HP469335	1	04HP469334	1	
13		ADAPTER										
		M56C	N/A		04HP410288	1	N/A		N/A		N/A	
		143TC	N/A		04HP410288	1	N/A		04HP410280	1	N/A	
		145TC	N/A		04HP410288	1	04HP410288	1	04HP410280	1	04HP410290	1
	182TC & 184TC	N/A		04HP410287	1	04HP410287	1	04HP410291	1	04HP410291	1	
	213TC	N/A		04HP410287	1	04HP410287	1	04HP410291	1	04HP410291	1	
	215TC	N/A		04HP410287	1	04HP410287	1	04HP410291	1	N/A		
	254TC	N/A		N/A		04HP460862	1	04HP410291	1	N/A		
	256TC	N/A		N/A		04HP460862	1	04HP410291	1	04HP410291	1	
	284TSC & 286TSC	N/A		N/A		04HP452228	1	04HP410370	1	04HP410370	1	
	324TSC & 326TSC	N/A		N/A		N/A		N/A		04HP410371	1	

"V2" Series Industrial Centrifugal Pump
Models 14V², 16V², 18V², 18VS²

OPTIONS

ITEM	DESCRIPTION	14V ² PART NO.	QTY	16V ² PART NO.	QTY	18VS ² PART NO.	QTY	18V ² PART NO.	QTY	18VS ² PART NO.	QTY
14	SLINGER - OIL			N/A		N/A		N/A		N/A	
	56C	04HP288836	1	04HP288836	1	N/A		N/A		N/A	
	M56C	04HP288836	1	N/A		N/A		N/A		N/A	
	K36C	04HP242591	1	04HP242591	1	N/A		04HP242591	1	N/A	
	143TC	04HP242591	1	04HP242591	1	04HP242591	1	04HP242591	1	04HP242591	1
	145TC										
22	SCREW - Hex Head Cap (zinc plated)										
	M56C	N/A	4	N/A	4	N/A		N/A		N/A	
	143TC	N/A	4	N/A	4	N/A		522V006752	4	N/A	
	145TC	N/A	4	522V006752	4	522V006752	4	522V006752	4	522V006752	4
	182TC & 184TC	N/A	4	522V006788	4	522V006788	4	522V006788	4	522V006788	4
	213TC	N/A	4	522V006788	4	522V006788	4	522V006788	4	N/A	
	215TC	N/A	4	N/A	4	522V006788	4	522V006788	4	N/A	
	254TC	N/A	4	N/A	4	522V006788	4	522V006788	4	522V006788	4
	256TC	N/A	4	N/A	4	522V006788	4	522V006788	4	522V006788	4
	284TSC & 286TSC	N/A		N/A		N/A		N/A		N/A	
	324TSC & 326TSC	N/A		N/A		N/A		N/A		N/A	
36	SHAFT - Impeller (Type 3 or 4 Seal)										
	56C (5/8 in.)	04HP414026	1	N/A	1	N/A		N/A		N/A	
	M56C (5/8 in.)	04HP414026	1	04HP414051	1	N/A		N/A		N/A	
	K56C (5/8 in.)	04HP414026	1	N/A	1	N/A		N/A		N/A	
	143TC (7/8 in.)	04HP414027	1	04HP414052	1	N/A		04HP414084	1	N/A	
36	SHAFT - Impeller (Type 3 or 4 Seal)										
	145TC (7/8 in.)	04HP414027	1	04HP414052	1	04HP414052	1	04HP414084	1	04HP414146	1
	182TC & 184TC (1-1/8 in.)	N/A	1	04HP414054	1	04HP490891	1	04HP414086	1	04HP414148	1
	213TC (1-3/8 in.)	N/A	1	04HP414055	1	04HP490888	1	04HP414087	1	04HP414149	1
	215TC (1-3/8 in.)	N/A	1	04HP414055	1	04HP490888	1	04HP414087	1	N/A	
	254TC (1-5/8 in.)	N/A	1	N/A	1	04HP482224	1	04HP414088	1	N/A	
	256TC (1-5/8 in.)	N/A	1	N/A	1	04HP482224	1	04HP414088	1	04HP414150	1
	284TSC & 286TSC (1-5/8 in.)	N/A	1	N/A	1	04HP482224	1	04HP414080	1	04HP414152	1
	324TSC & 326TSC (1-7/8 in.)	N/A	1	N/A	1	04HP482224	1	N/A	1	04HP414153	1

"V²" Series Industrial Centrifugal Pump
 Models 14V², 16V², 16VS², 18V², 18VS²

OPTIONS

ITEM	DESCRIPTION	14V ² PART NO.	QTY	16V ² PART NO.	QTY	16VS ² PART NO.	QTY	18V ² PART NO.	QTY	18VS ² PART NO.	QTY
47	LEG - Optional Assembly Kit										
	56C	04WP416275	1	04WP416276	1	N/A		N/A		N/A	
	M56C	04WP416275	1	04WP416276	1	N/A		N/A		N/A	
	K56C	04WP416275	1	04WP416276	1	N/A		N/A		N/A	
	143TC	04WP416275	1	04WP416276	1	N/A		04WP416279	1	04WP416279	1
	145TC	04WP416275	1	04WP416276	1	04WP416276	1	04WP416279	1	04WP416279	1
	182TC & 184TC	N/A		04WP416277	1	04WP416277	1	04WP416280	1	04WP416280	1
	213TC	N/A		04WP416278	1	04WP416278	1	04WP416281	1	04WP416281	1
	215TC	N/A		04WP416278	1	04WP416278	1	04WP416281	1	04WP416281	1
	254TC	N/A		N/A		04WP476504		04WP416282	1	04WP416282	1
	256TC	N/A		N/A		04WP476504		04WP416282	1	04WP416282	1
	284TSC & 286TSC	N/A		N/A		04WP476505		04WP452078	1	04WP452078	1
	324TSC & 326TSC	N/A		N/A		N/A		N/A		04WP452079	1



"V²" Series Industrial Centrifugal Pump
Models 14V², 16V², 16VS², 18V², 18VS²

Type 1 Seal

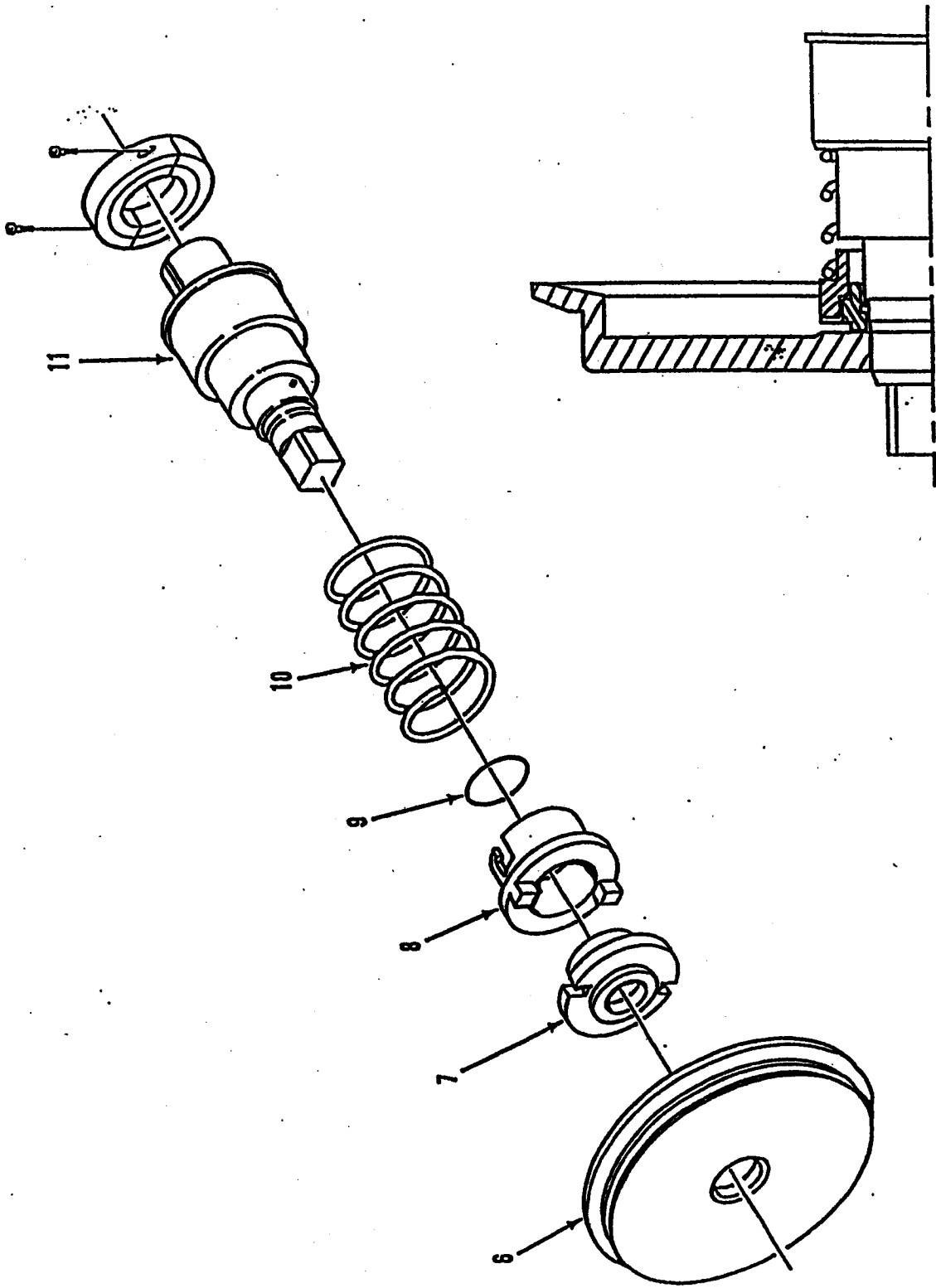

"V" SERIES INDUSTRIAL CENTRIFUGAL PUMP
Models 14V², 16V², 16VS², 18V², 18VS²

Type 1 Seal

ITEM	DESCRIPTION	14V ² PART NO.	QTY	16V ² PART NO.	QTY	16VS ² PART NO.	QTY	18V ² PART NO.	QTY	18VS ² PART NO.	QTY
6	PLATE - Back	04HP410292	1	04HP401852	1	04HP401852		04HP401823	1	04HP401823	1
7	RING - Seat (carbon) std.) RING - Seat (graphite - TFE) (optional)	546P331925	1	546P329693	1	546P329693	1	546P331198	1	546P331198	1
		04HP357739	1	04HP357740	1	04HP357740	1	04HP357741	1	04HP357741	1
8	RING - Drive	727P331926	1	727P337679	1	727P337679	1	727P331199	1	727P331199	1
9	O-RING - (Nitrile) (std.) (pkg of 10) O-RING - (Viton™) (optional) O-RING (EPDM) (optional)	**543S131315	1	**543S131320	1	**543S131320	1	**543S131324	1	**543S131324	1
		543P221164	1	543P221169	1	543P221169	1	543P221173	1	543P221173	1
		543K24210	1	543P239169	1	543P239169	1	543P239173	1	543P239173	1
10	SPRING	04HP149543	1	04HP339834	1	622P339833	1	04HP342824	1	04HP342824	1
11	SHAFT - Impeller										

*See the Pump Options section for customer option.
 **Certain items are packaged in minimum quantity lots as indicated.

"V²" Series Industrial Centrifugal Pump
Models 14V², 16V², 16VS², 18V², 18VS²

Type 2 Seal

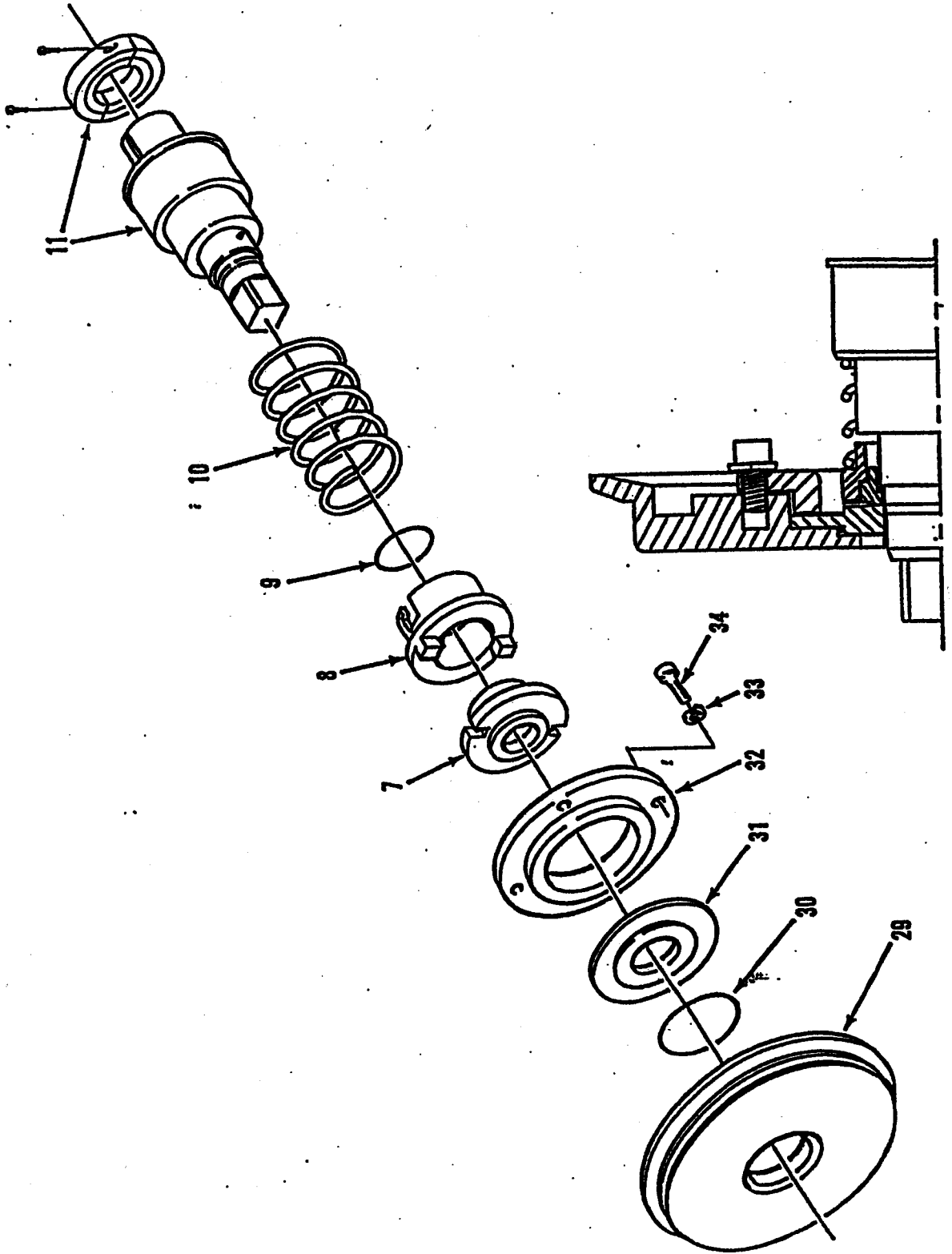

"V²" SERIES INDUSTRIAL CENTRIFUGAL PUMP
 Models 14V², 16V², 16VS², 18V², 18VS²

Type 2 Seal

ITEM	DESCRIPTION	14V ² PART NO.	QTY	16V ² PART NO.	QTY	16VS ² PART NO.	QTY	18V ² PART NO.	QTY	18VS ² PART NO.	QTY
7	RING - Seat (carbon) (std.)	546P331925	1	546P329893	1	546P329893	1	546P331198	1	546P331198	1
	RING - Seat (graphite - TFE) (optional)	04HP357739	1	04HP357740	1	04HP357740	1	04HP357741	1	04HP357741	1
	RING - Seat (siliconized carbon) (optional)	***546P410943	1	***546P365566	1	***546P365566	1	***546P365567	1	***546P365567	1
8	RING - Drive	727P331926	1	727P337679	1	727P337679	1	727P331199	1	727P331199	1
9	O-RING (Nitrile) (std.) (pkg of 10)	**543S131315	1	**543S131320	1	**543S131320	1	**543S131324	1	**543S131324	1
	O-RING (Viton TM) (optional)	543P221164	1	543P221169	1	543P221169	1	543P221173	1	543P221173	1
	O-RING (EPDM) (optional)	543P239164	1	543P239169	1	543P239169	1	543P239173	1	543P239173	1
10	SPRING	04HP149543	1	04HP339834	1	622P339833	1	04HP342824	1	04HP342824	1
11	SHAFT - Impeller	*		*		*		*		*	
29	PLATE - Back	04HP410278	1	04HP410284	1	04HP410284	1	04HP410289	1	04HP410289	1
30	O-RING (Nitrile) (std.) (pkg of 10)	**543S1313CQ	1	**543S1313CV	1	**543S1313CV	1	**543S1313DD	1	**543S1313DD	1
	O-RING (Viton TM) (optional)	543P319662	1	543P319667	1	543P319667	1	543P319675	1	543P319675	1
	O-RING (EPDM) (optional)	543SK24128	1	543SK24133	1	543SK24133	1	543SK24141	1	543SK24141	1
31	INSERT - Seal (ss) (std.)	04HP421751	1	04HP421752	1	04HP421752	1	04HP421753	1	04HP421753	1
	INSERT - Seal (silicon carbide) (optional)	546P436617	1	546P436618	1	546P436618	1	546P436619	1	546P436619	1
32	RING - Insert Holder	04HP410615	1	04HP410616	1	04HP410616	1	04HP410617	1	04HP410617	1
33	WASHER - Lock (ss) (pkg of 10)	**523V007189	4	**523V007190	4	**523V007190	4	**523V007190	4	**523V007190	4
34	SCREW - Socket Head Cap (ss)	521V006692	4	521V020366	4	521V020366	4	521V020366	4	521V020366	4

*See the Pump Options section for customer option.
 **Certain items are packaged in minimum quantity lots as indicated.
 ***Use siliconized carbon seat ring only with silicon carbide seal insert.

1 1/2" Series Industrial Centrifugal Pump
Models 14V², 16V², 16VS², 18V², 18VS²

Type 3 Seal

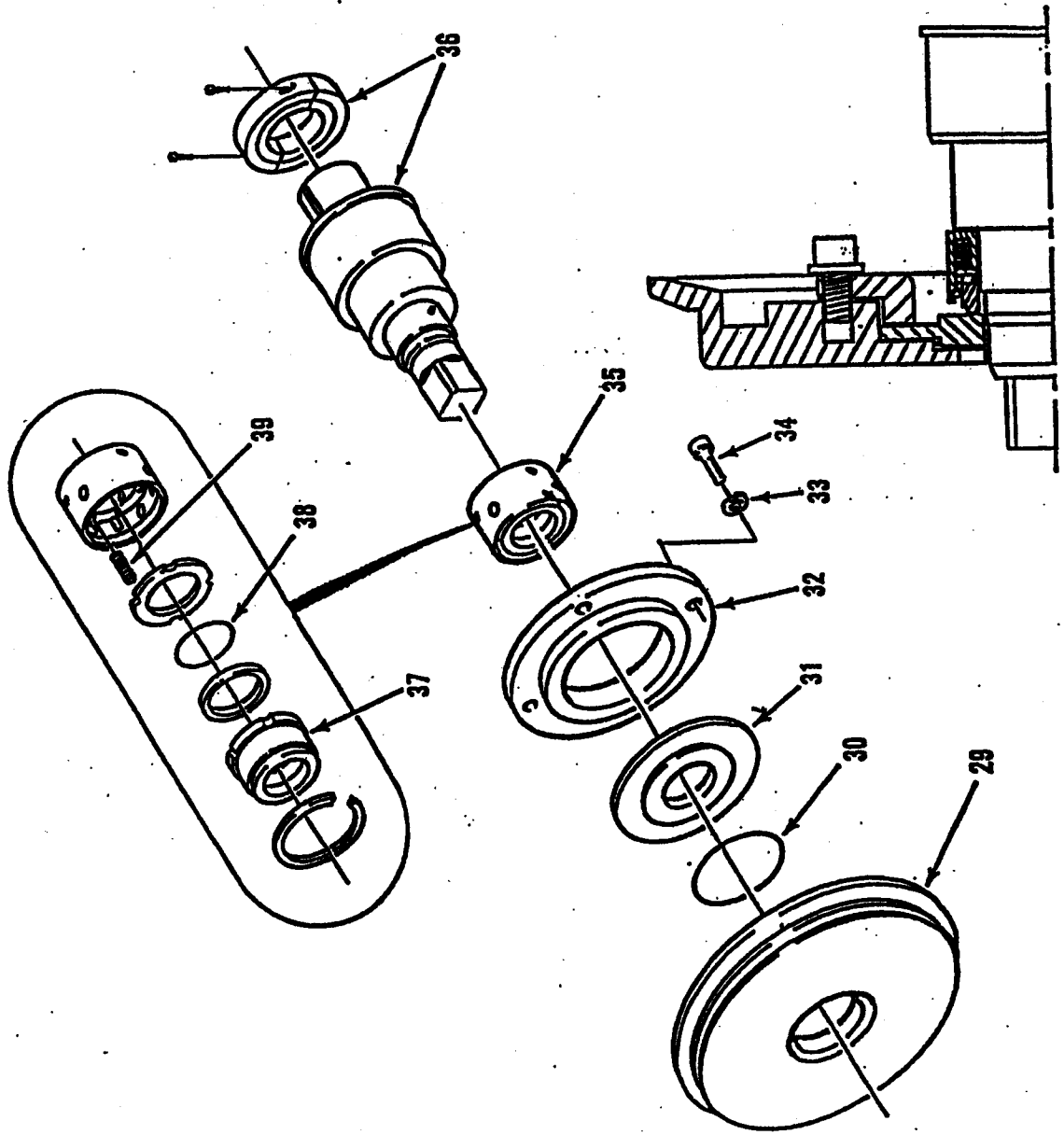

"V²" Series Industrial Centrifugal Pump
Models 14V², 16V², 16VS², 18V², 18VS²

Type 3 Seal

ITEM	DESCRIPTION	14V ² PART NO.	QTY	16V ² PART NO.	QTY	16VS ² PART NO.	QTY	18V ² PART NO.	QTY	18VS ² PART NO.	QTY
29	PLATE - Back	04HP410278	1	04HP410284	1	04HP410284	1	04HP410289	1	04HP410289	1
30	O-RING (Nitrile) (std.) (pkg of 10)	**543S1313CQ	1	**543S1313CV	1	**543S1313DD	1	**543S1313DD	1	**543S1313DD	1
		543P319667	1	543P319667	1	543P319675	1	543P319675	1	543P319675	1
		543SK24128	1	543SK24133	1	543SK24141	1	543SK24141	1	543SK24141	1
31	INSERT - Seal (ss) (std.)	04HP421761	1	04HP421762	1	04HP421762	1	04HP421763	1	04HP421753	1
		546P436617	1	546P436618	1	546P436618	1	546P436619	1	546P436619	1
32	INSERT - Seal (silicon carbide) (optional)	04HP410615	1	04HP410616	1	04HP410616	1	04HP410617	1	04HP410617	1
33	RING - Insert Holder	**523V007189	4	**523V007190	4	**523V007190	4	**523V007190	4	**523V007190	4
34	WASHER - Lock (ss) (pkg of 10)	521V006892	4	521V020366	4	521V020366	4	521V020366	4	521V020366	4
35	SCREW - Socket Head Cap (ss)	549SK378A	1	549SK378B	1	549SK378B	1	549SK378C	1	549SK378C	1
36	SEAL - Mechanical (John Crane™)										
37	SHAFT - Impeller										
38	SEAL - Carbon	549SK377A	1	549SK377B	1	549SK377B	1	549SK377C	1	549SK377C	1
39	O-RING (Nitrile) (std.) (pkg of 10)	**543S131317	1	**543S131323	1	**543S131323	1	**543S131327	1	**543S131327	1
		543P221166	1	543P221172	1	543P221172	1	543P221176	1	543P221176	1
		543P239166	1	543P239172	1	543P239172	1	543P239176	1	543P239176	1
39	O-RING (Viton™) (optional)	**622SK579A	6	**622SK579D	6	**622SK579D	6	**622SK579D	6	**622SK579D	6
39	O-RING (EPDM) (optional)										
39	SPRING (pkg of 10)										

*See the pump Options section for customer option.
 **Certain items are packaged in minimum quantity lots as indicated.

"V²" Series Industrial Centrifugal Pump
Models 14V², 16V², 16VS², 18V², 18VS²

Type 4 Seal

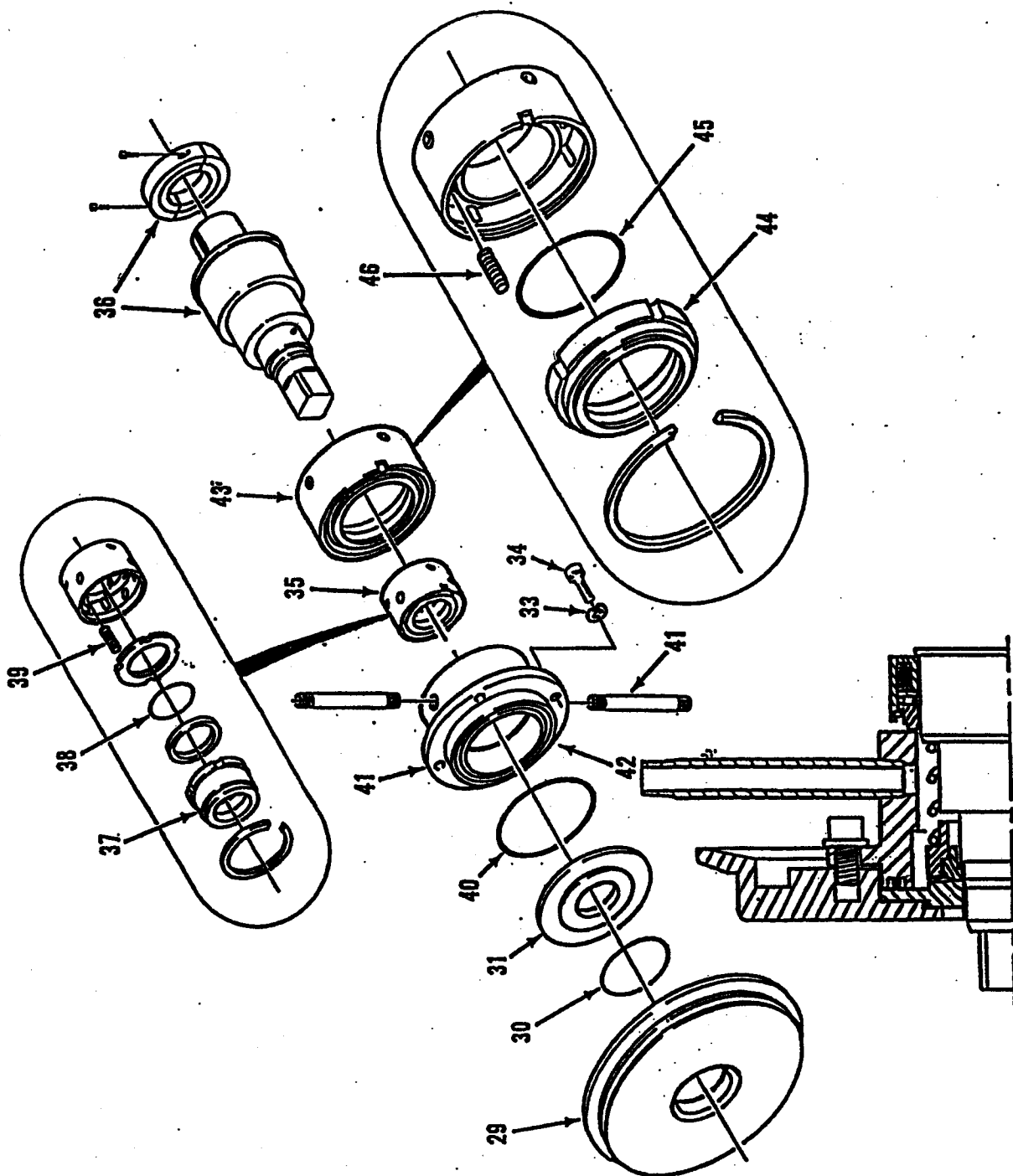

SVS Series Inaugural Centrifugal Pump
Models 14V², 16V², 18V², 18VS², 18V², 18VS²

Type 4 Seal

ITEM	DESCRIPTION	14V ² PART NO.	QTY	16V ² PART NO.	QTY	16VS ² PART NO.	QTY	18V ² PART NO.	QTY	18VS ² PART NO.	QTY
29	PLATE - Back	04HP410278	1	04HP410284	1	04HP410284	1	04HP410288	1	04HP410289	1
30	O-RING (Nitrile) (std.) (pkg of 10)	**543S1313CQ	1	**543S1313CV	1	**543S1313CV	1	**543S1313DD	1	**543S1313DD	1
	O-RING (Viton™) (optional)	543P319662	1	543P319667	1	543P319667	1	543P319675	1	543P319675	1
	O-RING (EPDM) (optional)	543SK24128	1	543SK24133	1	543SK24133	1	543SK24141	1	543SK24141	1
31	INSERT - Seal (ss) (std.)	04HP421751	1	04HP421752	1	04HP421752	1	04HP421753	1	04HP421753	1
	INSERT - Seal (silicon carbide) (optional)	546P436617	1	546P436618	1	546P436618	1	546P436619	1	546P436619	1
33	WASHER - Lock (ss) (pkg of 10)	**523V007189	4	**523V007190	4	**523V007190	4	**523V007190	4	**523V007190	4
34	SCREW - Socket Head Cap (ss)	521V006692	4	521V020366	4	521V020366	4	521V020366	4	521V020366	4
35	SEAL - Mechanical (John Crane™)	549SK376A	1	549SK376B	1	549SK376B	1	549SK376C	1	549SK376C	1
36	SHAFT - Impeller										
37	SEAL (carbon)	549SK377A	1	549SK377B	1	549SK377B	1	549SK377C	1	549SK377C	1
38	O-RING (Nitrile) (std.) (pkg of 10)	**543S131317	1	**543S131323	1	**543S131323	1	**543S131327	1	**543S131327	1
	O-RING (Viton™) (optional)	543P221186	1	543P221172	1	543P221172	1	543P221176	1	543P221176	1
	O-RING (EPDM) (optional)	543P239168	1	543P239172	1	543P239172	1	543P239176	1	543P239176	1
39	SPRING (pkg of 10)	**622SK578A	6	**622SK578D	8	**622SK578D	8	**622SK578D	8	**622SK578D	8
40	O-RING (Nitrile) (std.) (pkg of 10)	**543S1313CZ	1	**543S131407	1	**543S131407	1	**543S131410	1	**543S131410	1
	O-RING (Viton™) (optional)	543P319671	1	543P284707	1	543P284707	1	543P284710	1	543P284710	1
	O-RING (EPDM) (optional)	543SK24137	1	543P239334	1	543P239334	1	543P239337	1	543P239337	1
41	NIPPLE	567V006089	2	567V005511	2	567V005511	2	567V020611	2	567V020611	2
42	CHAMBER - Water Seal	04HP421754	1	04HP421755	1	04HP421755	1	04HP421756	1	04HP421756	1
	Stainless Steel (std.)	04HP416336	1	04HP416337	1	04HP416337	1	04HP416338	1	04HP416338	1
	Chrome Oxide, Coated (optional)										
43	SEAL - Mechanical (John Crane™)	549SK378A	1	549SK378B	1	549SK378B	1	549SK378C	1	549SK378C	1
44	SEAL (carbon)	549SK379A	1	549SK379B	1	549SK379B	1	549SK379C	1	549SK379C	1
45	O-RING (Nitrile) (std.) (pkg of 10)	**543S131402	1	**543S131404	1	**543S131404	1	**543S131408	1	**543S131408	1
	O-RING (Viton™) (optional)	543P284702	1	543P284704	1	543P284704	1	543P284708	1	543P284708	1
	O-RING (EPDM) (optional)	543P239329	1	543P239331	1	543P239331	1	543P239335	1	543P239335	1
46	SPRING (pkg of 10)	**622SK578B	4	**622SK579C	6	**622SK579C	6	**622SK579D	4	**622SK579D	4

*See the pump Options section for customer option.
 **Certain items are packaged in minimum quantity lots as indicated.

"V²" Series Industrial Centrifugal Pump
Models 14V², 16V², 16VS², 18V², 18VS²

Type 6 Seal

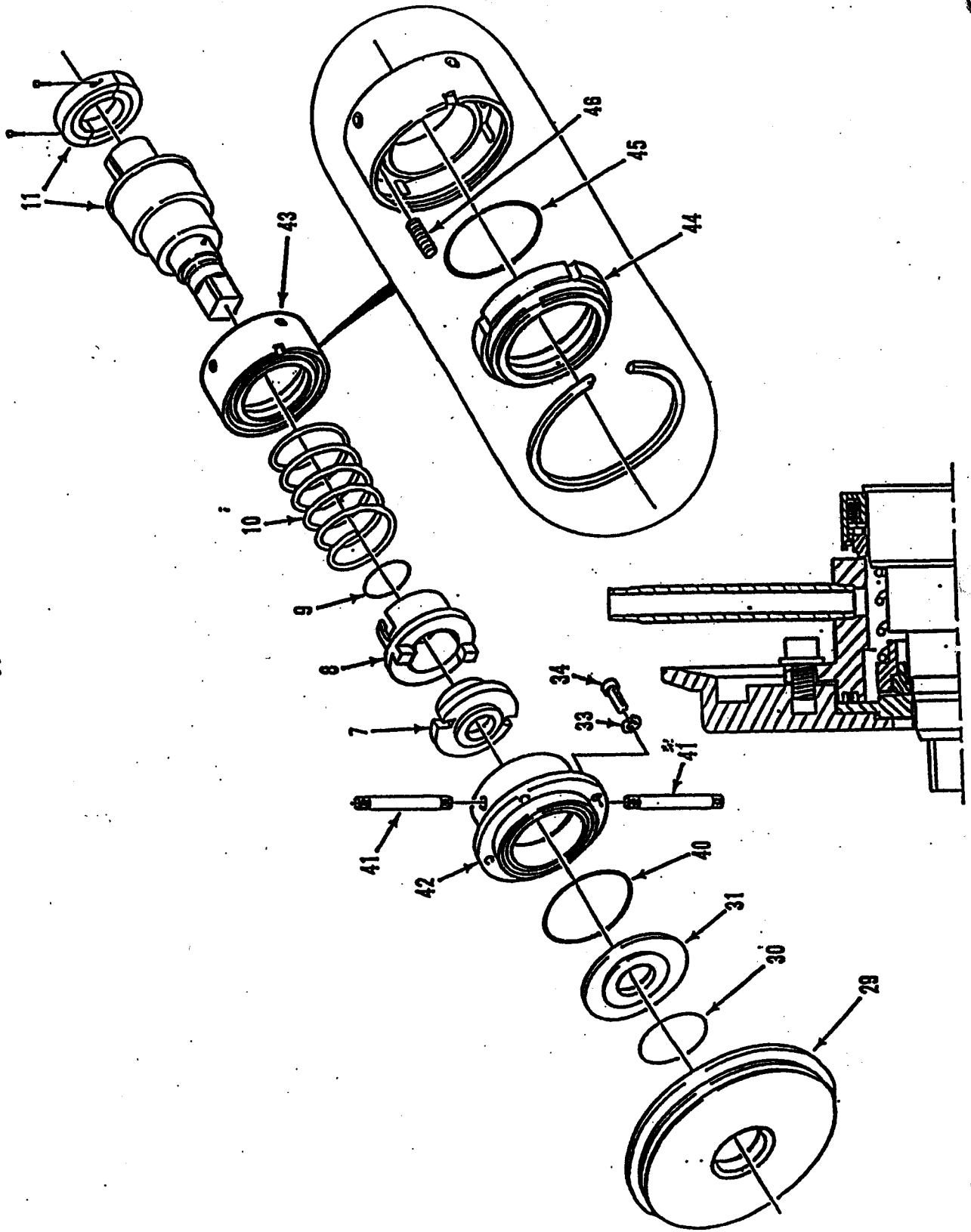

"V²" Series Industrial Centrifugal Pump
Models 14V², 16V², 18V², 18VS²

Type 6 Seal

ITEM	DESCRIPTION	14V ² PART NO.	QTY	16V ² PART NO.	QTY	16VS ² PART NO.	QTY	18V ² PART NO.	QTY	18VS ² PART NO.	QTY
7	RING - Seat (carbon) (std.)	546P331925	1	546P328693	1	546P328693	1	546P331198	1	546P331198	1
	RING - Seat (graphite - JFE) (optional)	04HP357739	1	04HP357740	1	04HP357740	1	04HP357741	1	04HP357741	1
	RING - Seat (siliconized carbon) (optional)	***546P410943	1	***546P365568	1	***546P365568	1	***546P365567	1	***546P365567	1
8	RING - Drive	727P331926	1	727P337679	1	727P337679	1	727P331199	1	727P331199	1
9	O-RING (Nitrile) (std.) (pkg of 10)	**543S131316	1	**543S131320	1	**543S131320	1	**543S131324	1	**543S131324	1
	O-RING (Viton™) (optional)	543P221184	1	543P221169	1	543P221169	1	543P221173	1	543P221173	1
	O-RING (EPDM) (optional)	543P239164	1	543P239169	1	543P239169	1	543P239173	1	543P239173	1
10	SPRING	622P3304634	1	622P3309834	1	622P3398933	1	622P3309824	1	622P3309824	1
11	SHAFT - Impeller										
29	PLATE - Back	04HP410278	1	04HP410284	1	04HP410284	1	04HP410289	1	04HP410289	1
30	O-RING (Nitrile) (std.) (pkg of 10)	**543S1313CQ	1	**543S1313CV	1	**543S1313CV	1	**543S1313DD	1	**543S1313DD	1
	O-RING (Viton™) (optional)	543P319662	1	543P319667	1	543P319667	1	543P319676	1	543P319676	1
	O-RING (EPDM) (optional)	543SK24128	1	543SK24133	1	543SK24133	1	543SK24141	1	543SK24141	1
31	INSERT - Seal (ss) (std.)	04HP421751	1	04HP421752	1	04HP421752	1	04HP421753	1	04HP421753	1
	INSERT - Seal (silicon carbide) (optional)	546P436617	1	546P436618	1	546P436618	1	546P436619	1	546P436619	1
33	WASHER - Lock (ss) (pkg of 10)	**523V007189	4	**523V007190	4	**523V007190	4	**523V007190	4	**523V007190	4
34	SCREW - Socket Head Cap (ss)	521V008692	4	521V020366	4	521V020366	4	521V020366	4	521V020366	4
40	O-RING (Nitrile) (std.) (pkg of 10)	**543S1313CZ	1	**543S131407	1	**543S131407	1	**543S131410	1	**543S131410	1
	O-RING (Viton™) (optional)	543P319671	1	543P284707	1	543P284707	1	543P284710	1	543P284710	1
	O-RING (EPDM) (optional)	543SK24137	1	543P239334	1	543P239334	1	543P239337	1	543P239337	1
41	NIPPLE	567V006099	2	567V005511	2	567V005511	2	567V020611	2	567V020611	2
42	CHAMBER - Water Seal Stainless Steel (std.) Chrome Oxide Coated (optional)	04HP421764 ***504HP416336	1 1	04HP421755 ***504HP416337	1 1	04HP421755 ***04HP416337	1 1	04HP421758 ***504HP416338	1 1	04HP421758 ***504HP416338	1 1
43	SEAL - Mechanical (John Crane™)	549SK378A	1	549SK378B	1	549SK378B	1	549SK378C	1	549SK378C	1
44	SEAL (carbon)	**549SK379A	1	**549SK379B	1	**549SK379B	1	**549SK379C	1	**549SK379C	1

*See the pump Options section for customer option.
**Certain items are packaged in minimum quantity lots as indicated.
***Use siliconized carbon seat ring only with silicon carbide seal insert.

"V²" Series Industrial Centrifugal Pump
 Models 14V², 16V², 16VS², 18V², 18VS²

Type 5 Seal

ITEM	DESCRIPTION	14V ² PART NO.	QTY	16V ² PART NO.	QTY	16VS ² PART NO.	QTY	18V ² PART NO.	QTY	18VS ² PART NO.	QTY
45	O-RING (Nitrile) (std.) (pkg of 10)	**543S131402	1	**543S131404	1	**543S131404	1	**543S131404	1	**543S131408	1
	O-RING (Viton™) (optional)	543P284702	1	543P284704	1	543P284704	1	543P284704	1	543P284708	1
	O-RING (EPDM) (optional)	543P239329	1	543P239331	1	543P239331	1	543P239335	1	543P239335	1
		**622SK579B	4	**622SK579C	6	**69SSK579C	6	**622SK379D	4	**622SK579D	4
46	SPRING (pkg of 10)										

**Certain items are packaged in minimum quantity lots as indicated.



Recommended Inventory of Spare Parts

Item Number

The listed item number refers to exploded views on preceding pages where applicable. Order by part number not by item number.

Item numbers which do not appear in the list are not recommended inventory.

Class I Duty

Suggested for domestic service and where some interruption in service is possible. Supplies typical service parts usage for 6 months or 1000 hours of service whichever occurs first.

Class II Duty

Suggested for export service or for domestic service where minimum loss of service is essential. Supplies typical service part usage for 1 year or 2000 hours of service whichever occurs first.

Class I .

Class II

ITEM	DESCRIPTION	QUANTITY	QUANTITY
2	PIN	10	20
3	O-RING	.	1
4	IMPELLER	3	6
5	GASKET	1	2
6	PLATE - Back	3	6
7	RING - Seal	.	1
8	RING - Drive	10	20
9	O-RING	.	1
10	SPRING	.	1
11	SHAFT - Impeller	.	1
14	SLINGER - Oil	.	1
17	NUT - Wing	.	2
25	RING - Lock	.	1
26	PIN - Pivot	.	2
28	PIN	.	1
29	PLATE - Back	10	20
30	O-RING	1	2
31	INSERT - Seal	3	6
35	SEAL - Mechanical (John Crane™)	.	1
36	SHAFT - Impeller	10	20
40	O-RING	3	6
43	SEAL - Mechanical (John Crane™)	.	.

*Refer to the Shaft Seal section.



Your local contact:



APV, An SPX Brand
611 Sugar Creek Rd.
Delavan, WI 53115
Phone: (888) 278-4321
Email: answers.us@apv.com

For more information about our worldwide locations, approvals, certifications, and local representatives, please visit www.apv.com.

SPX Corporation reserves the right to incorporate our latest design and material changes without notice or obligation. Design features, materials of construction and dimensional data, as described in this bulletin, are provided for your information only and should not be relied upon unless confirmed in writing.

Issued: 03/2009 04WP475770

Copyright © 2009 SPX Corporation