

## Waukesha Bredel Peristaltic Positive Displacement Pump

Mfg: Waukesha

Model: SP50

Stock No. BWSS04.4

Serial No. 51954

Waukesha Bredel Peristaltic Positive Displacement Pump. Model: SP50. S/N: 51954. Maximum capacity continuous: 46 gpm. Maximum capacity intermittently: 9 gpm. Capacity per revolution: 0.76 gal. Cast iron construction. Reliance Electric Duty Master Motor, 5 hp, 1730 rpm, 230/460 V, 14.0/7.0 amps, 60 Hz, 3 phase. Brook Hansen Drive, ratio of 45, 38 rpm (final). Applications include: corrosives, abrasives, shear sensitive fluids, high viscosity fluids, large solids, etc. The pump is equipped with a 1-1/2 in. dia. flange inlet and a 1-1/2 in. dia. flange outlet. Overall dimensions: 51-1/2 in. L x 33-1/2 in. W x 30 in. H.



## 10 SPECIFICATIONS

### 10.1 Pumphead

#### 10.1.1 Performance

Description	SP/10	SP/15	SP/20	SP/25	SP/32	SP/40	SP/50	SP/65	SP/80	SP/100
Max. capacity, continuous [m <sup>3</sup> /h]	0,11	0,38	0,62	1,80	3,25	6,0	10,5	20,0	28,0	36,0
Max. capacity, intermittently [m <sup>3</sup> /h] ◇	0,16	0,60	1,09	2,88	5,25	9,6	17,5	32,0	42,0	60,0
Capacity per revolution [l/rev]	0,022	0,083	0,152	0,30	0,625	1,33	2,9	6,7	11,7	20,0
Max. permissible discharge pressure [kPa]	750	750	750	1600	1600	1600	1600	1600	1600	1600
Permissible ambient temperature [°C]	- 20 to + 45									
Permissible product temperature [°C]	- 10 to + 80									
Sound level on 1m [dB(A)]	60	60	60	70	70	70	70	70	70	70

◇ Intermittent duty: "Let the pump stand still to cool down for at least 1 hour after 2 hours of operation".

#### 10.1.2 Materials

Description	Material
Pump housing	Cast-iron
Cover	SP/10, SP/15: synthetic optional: mild steel  SP/20 to SP/100: steel
Pump rotor	Cast-iron
Pressing shoe	Aluminum (not applicable for SP/10, SP/15 and SP/20)
Pump support	Mild steel, galvanized
Flange bracket	Mild steel, galvanized
Mounting material of pump cover	Mild steel, galvanized
Mounting material of pump support	Mild steel, galvanized
Seals	Nitrile
Bush	Neoprene

#### 10.1.3 Lubricant

Required quantity of lubricant [Liters]									
SP/10	SP/15	SP/20	SP/25	SP/32	SP/40	SP/50	SP/65	SP/80	SP100
0,25	0,50	0,50	2	3	5	10	20	40	60

### 10.1.4 Surface treatment

The pumphead is provided with a two component epoxy base coat. After drying the layer thickness must be at least 30 microns.

Subsequently these components are provided with a two component polyurethane top coat, in the RAL 5017 colour blue and with a 100% gloss rate. After this coat of paint has dried the layer thickness must be at least 30 microns.

All galvanized parts, exclusive of mounting articles, have been provided with an electrolytic zinc layer of 15 –20 microns.

### 10.1.5 Weights and dimensions

Description	Weights and dimensions per pump model									
	series	SP/10	SP/15	SP/20	SP/25	SP/32	SP/40	SP/50	SP/65	SP/80
Net weight pump (kg)	10	19	19	59	85	139	195	395	600	955
Gross weight pump (kg)	10	19	19	80	125	175	265	450	680	1055
Dimensions crate (cm)	30x26x27	37x32x28	37x32x28	72x56x55	87x62x65	87x76x63	106x90x68	127x105x84	148x124x93	170x145x107
Cubage (m <sup>3</sup> )	-	-	-	0,222	0,35	0,42	0,65	1,12	1,71	2,64
Dimension pump hose (mm)	10x31x510	15x36x755	19x36x755	25x53x1005	32x61x1250	40x66x1490	50x80x1820	65x99x2335	80x120x2780	100x144x3275
Weight pump hose (kg)	0,35	0,70	0,70	2	3	3,80	6,40	11,50	21	31
Quantity lubricant required (litres)	0,25	0,50	0,50	2	3	5	10	20	40	60
Weight lubricant (kg)	0,30	0,60	0,60	2,5	3,6	6	13	26	52	78
Weight supports [set] (kg)	0,75	1,60	1,60	17	24	43	56	50	92	160
Weight pump shaft (kg)	0,50	0,90	0,90	2	5	5	9,50	18	39	53
Weight rotor (kg)	0,75	2,50	2,50	4	8	12	24	44	69	108
Weight pressing shoes [set] (kg)	-	-	-	0,70	1,10	2	2,50	5	8	13
Weight pump cover (kg)	0,2	0,65	0,65	7	10	16	24	54	89	123
Weight pump housing (kg)	5,70	10,7	10,7	21	40	50,50	82	170	238	390
Flange connection, without inserts [set] (kg)	1,47	1,72	1,90	2,98	4,26	4,88	6,38	7,80	11,4	14,9
Insert [set] (kg)	0,04	0,05	0,07	0,13	0,18	0,34	0,46	3,13	4,06	5,69

---

**10.1.6 Torques**

Description	Torques in [Nm] per pump type									
	SP/10	SP/15	SP/20	SP/25	SP/32	SP/40	SP/50	SP/65	SP/80	SP/100
Pressing shoe	-	-	-	30	40	120	160	160	160	160
Cover	3,5	3,5	10	25	50	50	50	50	50	85
Inspection window	-	-	-	1,75	1,75	1,75	1,75	1,75	3,5	3,5
Hose clamp	2	2	2	12	12	12	12	12	12	12
Rubber bush clamp	1,75	1,75	1,75	1,75	1,75	1,75	1,75	1,75	1,75	1,75
Flange bracket	10	10	10	25	50	50	50	85	210	210
Support	25	25	25	50	85	85	85	210	410	710

10.1.7 Shimming

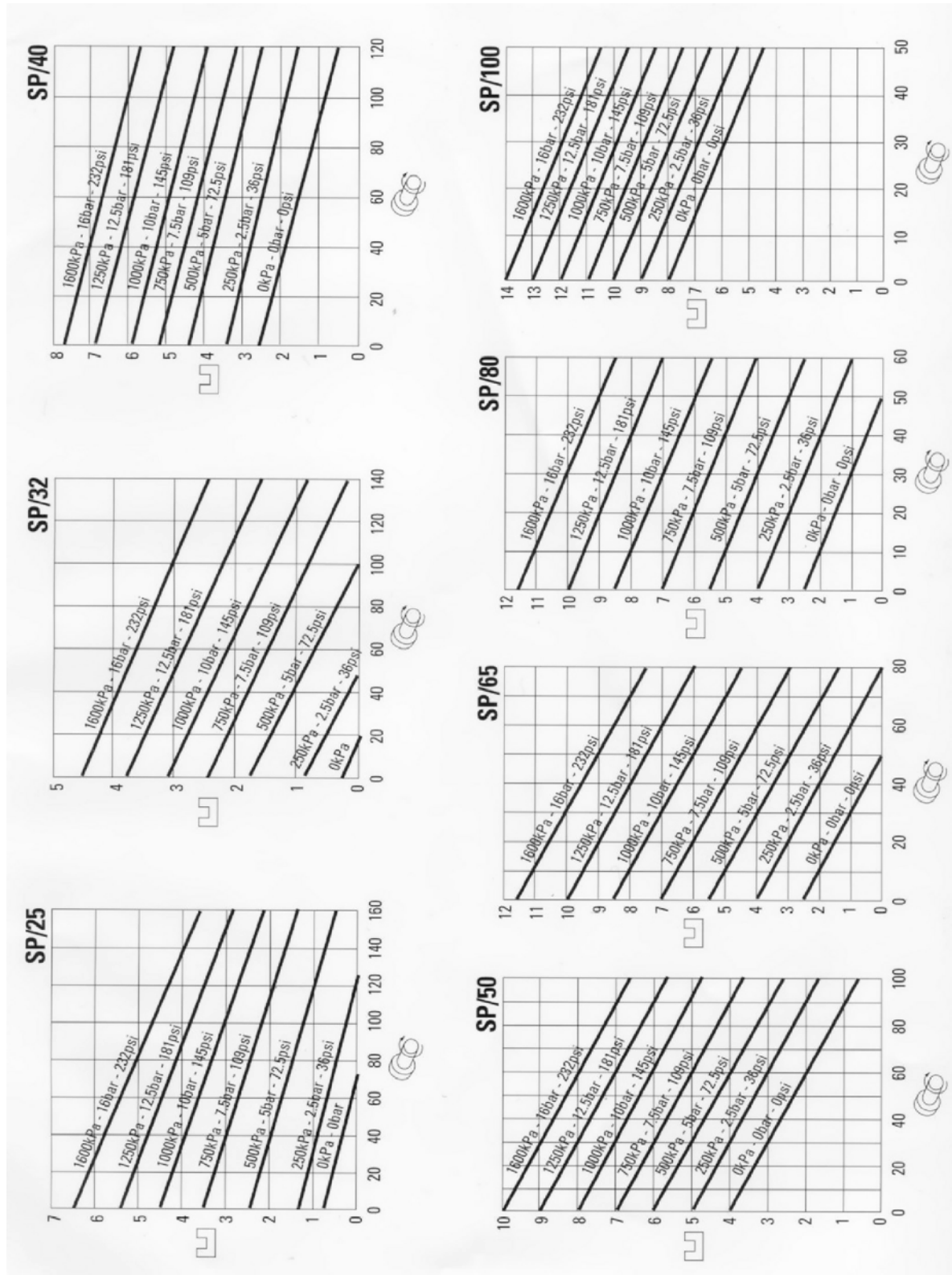

When the temperatures are above 60 °C (140 °F) always use one shim less than indicated. Always round up in number of shims.

## Dimensional drawings SP/25, SP/32, SP/40 and SP/50

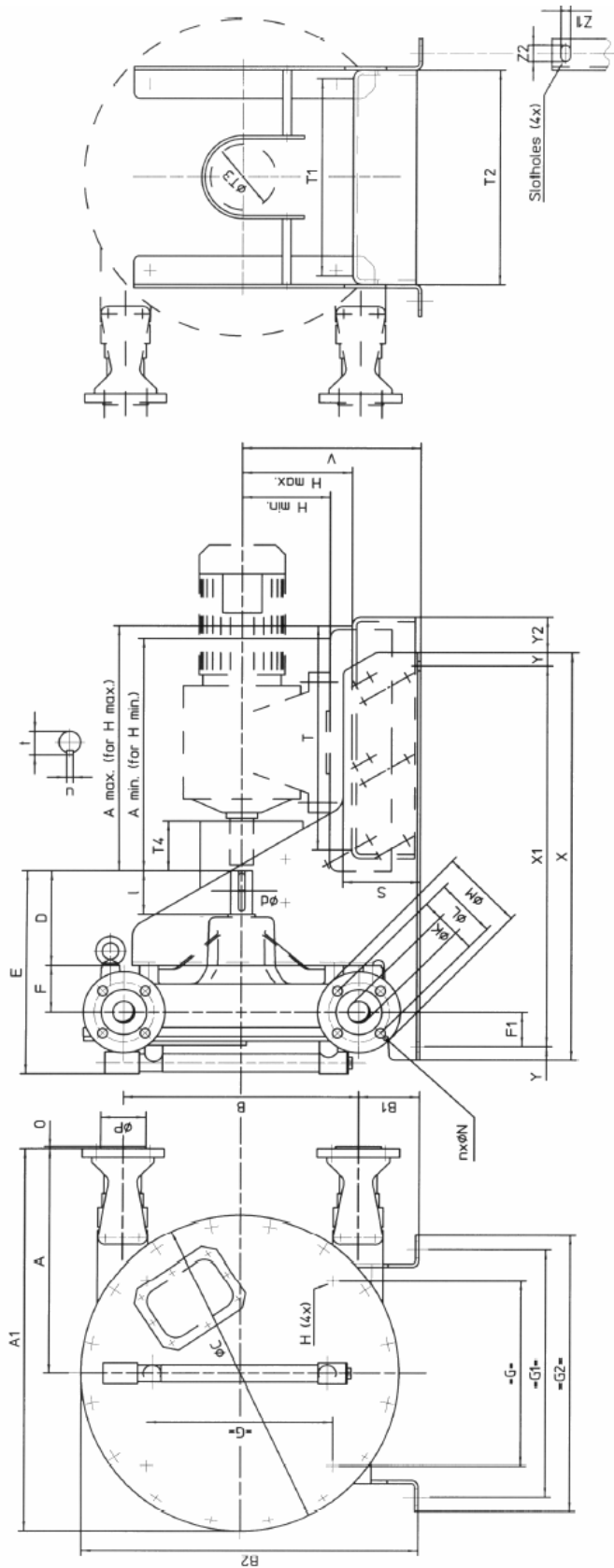

TYPE	S	T	T1	A <sub>max</sub>	A <sub>min</sub>	B	max. T3	T4	V	X	X1	Y	Y2	Z1	Z2	Ød	l	U	t
SP/25	102	311	242	266	110	67	230	600	550	25	33	12	18	30k6	60	8	33		
SP/32	120	376	294	318	140	91	270	750	700	25	-	12	18	40k6	80	12	43		
SP/40	140	412	360	392	140	91	325	750	700	25	61	18	30	40k6	80	12	43		
SP/50	172	466	346	380	170	112	400	920	870	25	50	18	30	50k6	100	14	53.5		

TYPE	A	A1	A <sub>max</sub>	A <sub>min</sub>	B	B1	B2	C	D	E	F	F1	G	G1	G2	H	H <sub>max</sub>	H <sub>min</sub>	K	L	M	n x N	O (insert)	P (insert)		
SP/25	304	490	347	322	264	98	416	372	123	285	69	51	220	322	366	M10	151	109	25	85	115	4x14	2.5	10	64	60
SP/32	375	613	371	336	330	105	508	476	174	365	89	61	266	374	418	M12	181	114	32	100	140	4x18	2.5	10	73	70
SP/40	412	702	446	401	430	110	615	580	174	365	86	64	340	454	508	M12	201	123	40	110	150	4x18	2.5	10	83	80
SP/50	475	835	522	462	554	123	760	720	223	440	102	78	440	444	496	M12	251	149	50	125	165	4x18	3	10	100	90



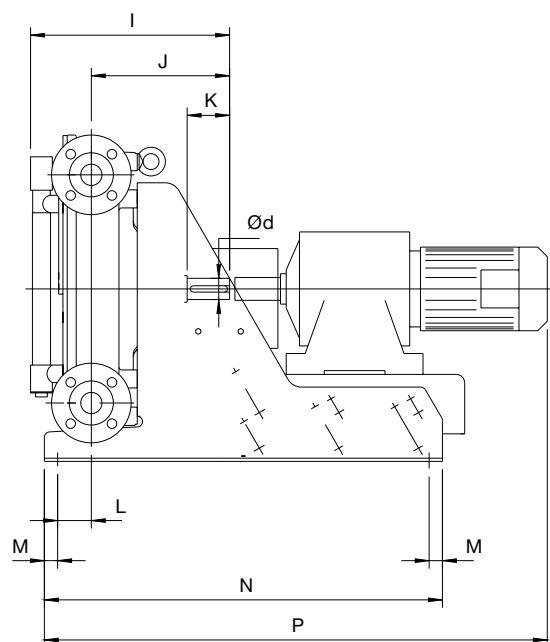
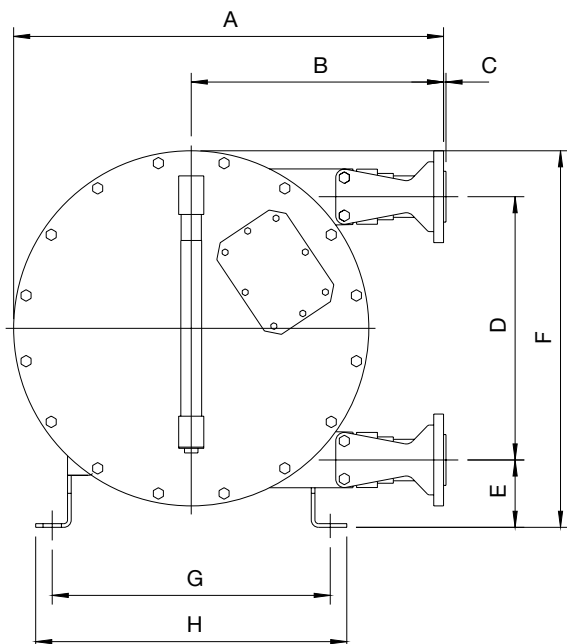

Type	A	B	C	D	E	F	G	H	I	J	K	L	M	N	d	P
SP25	490	304	2,5	264	98	416	322	336	285	192	60	51	25	600	30k6	*
SP32	613	375	2,5	330	105	508	374	418	365	263	80	61	25	750	40k6	*
SP40	702	412	2,5	430	110	615	454	508	365	260	80	64	25	750	40k6	*
SP50	835	475	3	554	123	760	444	496	440	325	100	78	25	920	50k6	*

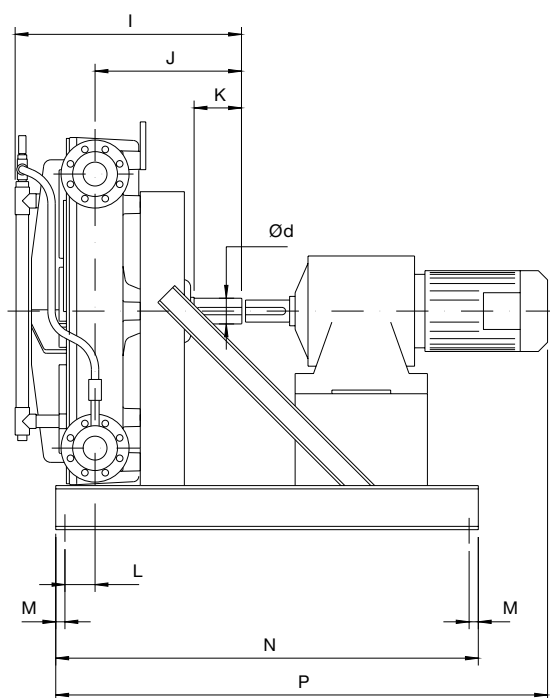
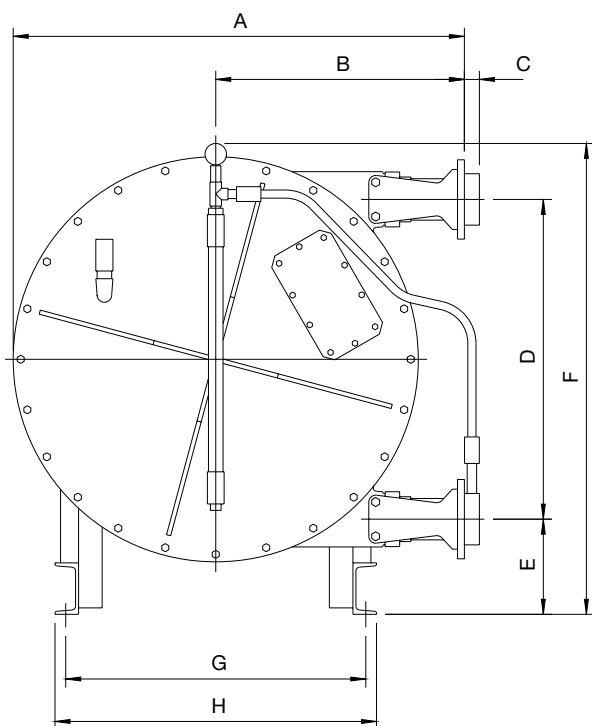

Type	A	B	C	D	E	F	G	H	I	J	K	L	M	N	d	P
SP65	1053	580	35	746	153	1013	580	680	630	400	130	82	25	1150	70m6	*
SP80	1253	700	35	876	262	1253	820	875	705	440	150	83	50	1250	80m6	*
SP100	1463	815	35	1042	299	1468	970	1035	880	472	200	100	50	1575	100m6	*

\* Contact your representative

The information contained in this document is believed to be correct but Bredel Hose Pumps B.V. accepts no liability for any errors it contains, and reserves the right to alter specifications without notice.

SPX and Bredel are registered trademarks. Bredel: worldwide supplier of industrial high pressure hose pumps.