



OPERATING AND INSTALLATION MANUAL

SLD/DLD/PLD AIR COOLED CONDENSING UNITS

SLD SERIES COND. UNITS

R-22, R-404A/R-507

10-60 HP.

DLD SERIES COND. UNITS

R-22, R-404A/R-507

7-50 HP./CIRCUIT

PLD SERIES COND. UNITS

R-22, R-404A/R-507

14-100 HP.

TABLE OF CONTENTS

I. Receipt of Equipment.....3
II. Refrigeration Piping.....3
III. System Evacuation.....5
IV. Electrical.....5
V. Charging the System.....5
VI. Operation Checkout.....5
VII. Features and Controls.....6
VIII. Normal Maintenance.....7

TABLES:

**Table 1 : Recommended
Line Sizes.....8,9**
**Table 2 : Condensing Unit
Refrigerant Charge..10,11,12**
**Table 3 : Low Pressure
Control Settings.....13**
**Table 4 : Fan Cycling
Control Settings.....13**

Large Condensing Unit Model Key

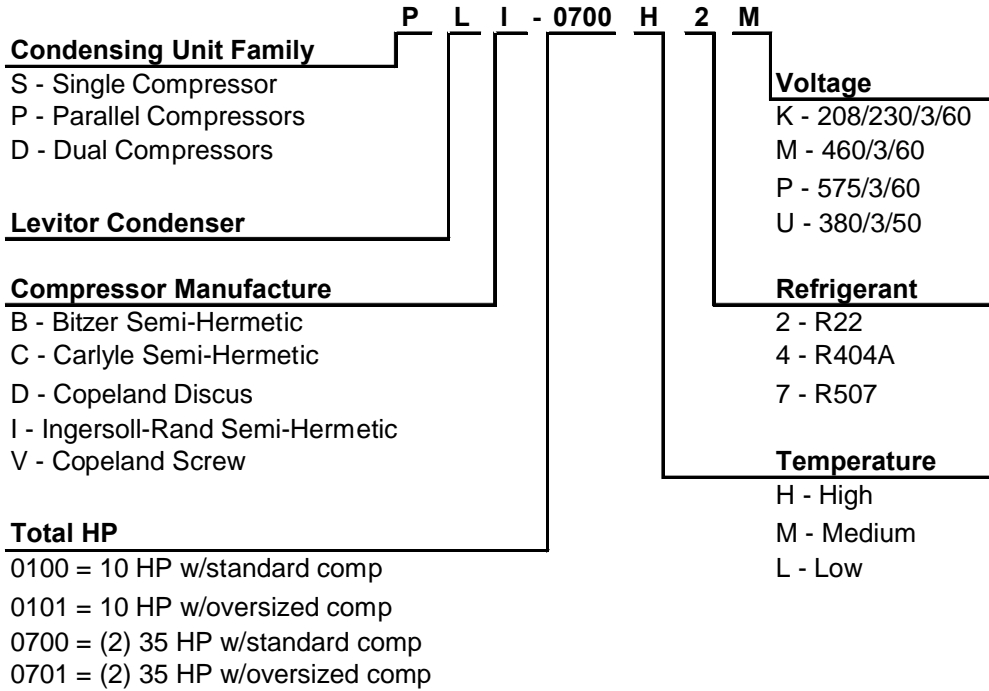

I. RECEIPT OF EQUIPMENT

A) DAMAGE CHECK

All equipment should be carefully checked for damage as soon as it is received. If any damage is evident, a notation must be made on the delivery receipt before it is signed and claim should then be filed against the freight carrier.

B) CHECK VOLTAGE

Carefully check nameplate voltage and current characteristics to be sure unit is compatible with power supply.

C) HANDLING

Never hoist the unit from any point excepting the base lifting holes provided for this purpose.

Lift with spreader and hooks as shown in Figure 1. When moving unit by forklift, lift from compressor end ONLY. Do not lift from condenser end.

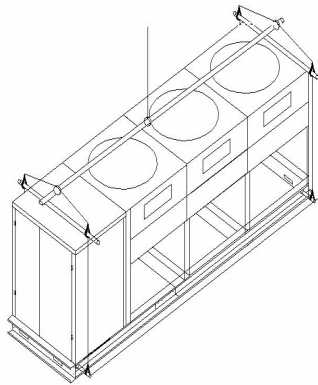

FIGURE 1

D) LEVELING AND BOLT DOWN PROCEDURE

A solid level foundation should be provided for the unit large enough to accommodate the full length of the base rails. If the mounting location is not sturdy and perfectly level, place shims under low points before tightening down with hold-down bolts.

Improper bolting-down procedure can seriously warp the framework, particularly with the large condenser fan units (3 fans or more).

E) UNIT LOCATION

Large air-cooled condensing units dissipate a tremendous amount of heat and require large volumes of air. Short-circuiting of the condenser air, or restricting the free entry of air into the coil will result in reduced capacity and highpower consumption. Take care to reduce such negative operation effects by providing for unrestricted free air flow into and from the unit. At most, the unit should not be positioned so as to have no more than one of its sides positioned close to a vertical building side or wall. At that point, this should be a minimum of 3ø unit-to-wall free air clearance distance.

F) LOSS OF GAS HOLDING CHARGE

Each Condensing unit is evacuated to remove moisture, leak tested, and then shipped with a gas holding charge. Absence of this charge may indicate a leak has developed in transit. The system should not be charged with refrigerant until it is verified that there is no leak or the source of the leak is located.

G) CHECK COMPRESSOR

The compressor is bolted to the base of the condensing unit using solid mounting techniques.

Check the compressor mounting bolts. Tighten these bolts as much as possible to prevent excess vibration. Check electrical junction connections of the compressor; tighten only those that may have come loose during transit.

II. PIPING

1) REFRIGERATION PIPING

Use ACR grade copper tubing, or conform otherwise to local and national codes. Piping methods must meet these codes and result in acceptable piping practice.

A) SUCTION LINE

Design and sizing of the suction line is critical to maintain:

- 1) Proper refrigerant velocity

- 2) Practical pressure drop (usually equivalent to 2 F maximum)
- 3) For proper oil return, all horizontal lines should be sloped downwards toward compressor at 1 inch per 10 feet.

Suction line risers must be trapped at the bottom of the rise and at every 20-foot increment for proper oil return. The proper balance is to design suction lines for approximately 1,200 ft. per min. velocity in risers and approximately 600 ft per min. velocity in horizontal lines. Oil traps should be installed at the bottom of all risers in suction lines for proper oil return.

Table 1 lists common suction line sizing which can be used with-but not instead of - ASHRAE- guidelines.

Suction lines should not be exposed to heat unless insulated. Insulation also prevents sweating and subsequent damage to goods.

B) LIQUID LINE

Avoid excessive liquid line pressure drop by using Table 1 and ASHRAE guidelines to size the liquid line. Install a liquid line solenoid valve at the evaporator.

On parallel compressor systems, if one compressor cycles off due to part load conditions, suction lines must be sized to allow for oil return under reduced load conditions.

2) LINE FABRICATION & SOLDERING

Copper pipe should be cut with a wheel type cutter and not with a hacksaw. Using a hacksaw produces copper filings which can cause problems if it gets into the system. Also, if the pipes to be used are not capped and perfectly clean, they should be cleaned with a clean lint free rag before fabrication into the system.

Soft solders should be avoided wherever possible, as in most cases they require the use of a flux. Most of the low temperature

solder flux consists of heavy wax type materials which if allowed to enter the system cause excessive service problems in the form of wax at expansion valves which looks like moisture but cannot be removed by the average dryer core. Where silver brazing must be used between copper and brass or copper and steel joints, care should be taken to avoid excessive use of flux lest it be introduced into the system to create problems at a later date. Easy-Flo or silver solders which contain sufficient silver content to still retain joint strength and yet require minimum use of flux are recommended here.

For copper to copper joints phos-copper solders with 4 to 15% silver content are recommended. No flux is required, and the resultant joints are of maximum strength without brittleness.

Nitrogen should be used to exclude the oxygen within the pipes during soldering in order to prevent the creation of large quantities of copper oxide. Copper oxide is a good abrasive and if it gets into the compressor it can cause excessive wear and/or shorting out of electric motor windings.

3) LEAK TESTING

When all refrigeration connections have been completed, the entire system must be tested for leaks. With all valves in the system open, pressurize the system to no more than 175 PSIG with refrigerant and dry nitrogen. The use of an electronic type leak detector is highly recommended.

III. SYSTEM EVACUATION

CAUTION: DO NOT use the compressor as a vacuum pump.
DO NOT start the compressor while it is in vacuum.

A two-stage vacuum pump is recommended if moisture is to be removed by evacuation. A single-stage pump will not remove moisture. An electronic vacuum gauge calibrated in microns is recommended for recording vacuum. Connect the vacuum meter to some point on the system, such as the purge connection on the condenser, so the actual vacuum is read rather than the vacuum at the vacuum pump. The pump should be connected to both the low and high pressure sides with copper tube or high vacuum hoses (1/2 inch I.D. minimum)

A vacuum of 500 microns and below is recommended to effectively remove moisture from the system. Close the valve at the pump and watch the gauge. If the system contains moisture or a leak is present the vacuum gauge will show a rise in pressure. When there is no visible rise in system pressure for 12 hours after the vacuum valve is shut off, evacuation is complete.

IV. ELECTRICAL

The power supply voltage, phase and frequency must match what is shown in the condensing unit data plate. All wiring must be carefully checked against the condensing unit wiring diagram.

V. CHARGING THE SYSTEM

Weigh the refrigerant cylinder before charging the system so an accurate record can be made of the amount of refrigerant put in the system.

Connect the suction service gauge to the compressor suction service valve and the discharge service gauge to the receiver outlet port. The third hose from the charging manifold should be connected to the refrigerant cylinder.

CAUTION: NEVER charge liquid refrigerant through the suction side of the system.

When initially charging a system that is in a vacuum, liquid refrigerant can be directly added into the receiver until the system pressure equalizes with pressure in the refrigerant cylinder.

Start the system and finish charging until the sight glass is clear.

Outdoor condensing units are furnished with a condenser flooding type of head pressure control valve for cold weather operation. This valve should be set at 180 psig for better performance for this unit. The correct refrigerant charge must be added at start up. Table 2 indicates the refrigerant charge at different ambient temperature.

Determine the ambient temperature at the time of charging the system and locate this temperature at the top of table 2. Next locate the condensing unit model number and the refrigerant type on the left side of the table. Read from left to right until you reach the column for the days ambient temperature. Record the condensing unit charge at this set of conditions. Next locate the column for the winter design temperature and record the condensing unit charge. The difference between these two values is the additional refrigerant that must be added to the system for proper winter operation.

VI. OPERATION CHECKOUT

- 1) Check electrical connections, fan blade set screws and refrigerant connections. Be sure they are tight.
- 2) Check the low pressure control setting. See Table 3 for proper setting.
- 3) With the system operating, check the supply voltage. It must be within +/- 10% of the voltage marked on the unit nameplate.
- 4) Check the room thermostat setting. Be sure it functions properly.
- 5) Check the compressor amp draw. It must not exceed the value on the unit data plate.
- 6) After the room temperature is reached, the expansion valve superheat must be checked. Too low suction superheat may

cause liquid to return to the compressor. Too high suction superheat may cause excessive discharge temperatures. For maximum system capacity the minimum superheat must be 20 F and the maximum superheat must be 30 F to 40 F at the compressor for medium and low temperature, respectively.

7) After several hours of operation, check the compressor oil level. The oil level should be 1/2 the way up on the glass with the compressor off. Care must be taken to be sure the proper lubricant is used.

8) On freezer system after the coil is frosted, manually advance the defrost timer to initiate a defrost. Observe the defrost cycle to see if all controls are functioning properly and that the coil is clear of all frost before the system returns to refrigeration. Reset the defrost timer to the correct time of day.

9) After the room has reached temperature and the liquid line solenoid has closed, check the compressor to be sure it has pumped down and shut off. If the compressor continues to run, check the low pressure control setting as outlined in step #2.

VII. FEATURES AND CONTROLS

1) REFRIGERANT OIL

The oil level should be 1/2 the way up on the glass in the compressor with the compressor off. Oil level should be checked frequently during startup and during the first 48 hours of operating time. Since no dependable rule of thumb can be used, the only safe method is to carefully check the oil level and add as little oil as needed. If oil is required to be added, an oil pump is recommended to pump the oil directly into the compressor against suction pressure. Refrigerant oil should be purchased in sealed containers and should not be left open to atmosphere. Exposure to air and moisture for extended periods will result in contamination of the oil and cause harmful reactions in the compressor. Do not transfer oil from one container to another.

2) HIGH AND LOW PRESSURE CONTROLS

SLD/DLD/PLDs are furnished with individual manual reset high-pressure and low-pressure controls.

These are safety controls for the system. (See Table 3).

3) OIL FAILURE SWITCH

Each compressor on the Model SLD/PLD/DLD unit has its own electronic oil pressure control. Should oil pump differential pressure, measured between the pump inlet and outlet, fall below 9 psig for a period of two minutes, the control will open and stop the compressor.

A trip of the oil pressure safety control is a warning that the compressor has been running without proper lubrication. Repeated trips of the control are a clear indication that something in the system requires immediate attention and corrective action.

If system is plagued with oil failure safety switch tripouts, it is almost always traceable to one of the following sources.

- a) Shortage of oil in the compressor
- b) Oil trapping in the system
- c) Liquid slugback to the compressor for some reason.
- d) Compressor short cycling
- e) Refrigerant in the oil on startup
- f) Malfunctioning oil pump
- g) Clogged on the oil suction screen
- h) Excessively low suction pressure
- i) Possibly a defective control, but not probable
- j) Low refrigerant charge in low ambient conditions

4) CRANKCASE HEATERS

Crankcase heaters are provided to reduce the possibility of refrigerant condensing in the crankcase oil.

NOTE: The use of a crankcase heater installed on the compressor does not always assure that liquid refrigerant will not condense in the oil under severe weather conditions.

If the compressor is subjected to extremely low temperatures and the evaporator is in a relatively warm location, the temperature at the compressor may still drop below evaporator temperature in which case liquid refrigerant will condense in the oil.

5) ELECTRICAL POWER

Control voltage is 230/60/1 as standard. All condensing units are factory tested for operation before leaving the plant and direction of rotation of all condenser fans are checked to see that they are the same. However, on installation, phase reversals may cause the fans to run backward. It's obvious that this can only be corrected in the field. On start-up, be sure to check that fan rotation is according to arrow decal on or near the fan blade. Air flow is up (vertical). Reversing of any two wires of the power supply to the condenser fan contactor will change the direction of the fan rotation.

6) CONDENSER FAN CYCLING

Pressure switches are included to cycle all but the first condenser fan(s) in response to head pressure.

See Table 4 for suggested pressure settings used on all multiple condenser fan systems.

7) LOW AMBIENT FLOODING CONTROLS ARE STANDARD

Condenser Liquid Flooding utilizes a field-adjustable (100 to 225 psig) condensate holdback valve. Head pressure control valve for this unit should be set at 180 psig.

8) PUMPDOWN & RESET SWITCH

With toggle switch down in the reset and pumpdown position, the control circuit is reset and the liquid line solenoid valve is de-energized. This allows the compressor to pumpdown on the low-pressure control.

With the toggle switch up in the run position, the liquid solenoid valve is energized and allows the system to cycle on the room thermostat.

VIII. NORMAL MAINTENANCE

- 1) Check compressor oil sight glass for proper level and check visible piping for oil spots, which may indicate a refrigerant leak.
- 2) Check liquid refrigerant sight glass for proper charge. If refrigerant must be added, use charging procedure outline in section V.
- 3) Check inlet air side of condenser; surface should be free of foreign matter.

**TABLE 1A
RECOMMENDED LINE SIZES FOR R-22**

SYSTEM CAPACITY BTU/H	SUCTION LINE SIZE											
	SUCTION TEMPERATURE											
	+20° F Equivalent Suction Line Length				-20° F Equivalent Suction Line Length				Liquid Line Receiver to Expansion Valve			
	25'	50'	75'	100'	25'	50'	75'	100'	25'	50'	75'	100'
R-22												
36,000	7/8	1 1/8	1 1/8	1 3/8	1 1/8	1 3/8	1 3/8	1 3/8	3/8	1/2	1/2	1/2
42,000	7/8	1 1/8	1 1/8	1 1/8	1 1/8	1 3/8	1 3/8	1 5/8	3/8	1/2	1/2	1/2
48,000	7/8	1 1/8	1 1/8	1 1/8	1 1/8	1 3/8	1 3/8	1 5/8	1/2	1/2	1/2	1/2
54,000	1 1/8	1 1/8	1 1/8	1 3/8	1 3/8	1 3/8	1 5/8	1 5/8	1/2	1/2	1/2	1/2
60,000	1 1/8	1 1/8	1 1/8	1 3/8	1 3/8	1 3/8	1 5/8	1 5/8	1/2	1/2	1/2	1/2
66,000	1 1/8	1 1/8	1 3/8	1 3/8	1 3/8	1 5/8	1 5/8	1 5/8	1/2	1/2	5/8	5/8
72,000	1 1/8	1 3/8	1 3/8	1 3/8	1 3/8	1 5/8	1 5/8	2 1/8	1/2	1/2	5/8	5/8
78,000	1 1/8	1 3/8	1 3/8	1 3/8	1 3/8	1 5/8	1 5/8	2 1/8	1/2	1/2	5/8	5/8
84,000	1 1/8	1 3/8	1 3/8	1 3/8	1 3/8	1 5/8	2 1/8	2 1/8	1/2	5/8	5/8	5/8
90,000	1 1/8	1 3/8	1 3/8	1 5/8	1 3/8	1 5/8	2 1/8	2 1/8	1/2	5/8	5/8	5/8
120,000	1 3/8	1 3/8	1 5/8	1 5/8	1 5/8	2 1/8	2 1/8	2 1/8	5/8	5/8	5/8	7/8
150,000	1 3/8	1 5/8	1 5/8	2 1/8	2 1/8	2 1/8	2 1/8	2 5/8	5/8	7/8	7/8	7/8
180,000	1 3/8	1 5/8	1 5/8	2 1/8	2 1/8	2 1/8	2 5/8	2 5/8	5/8	7/8	7/8	7/8
210,000	1 5/8	2 1/8	2 1/8	2 1/8	2 1/8	2 5/8	2 5/8	2 5/8	5/8	7/8	7/8	7/8
240,000	1 5/8	2 1/8	2 1/8	2 1/8	2 1/8	2 5/8	2 5/8	2 5/8	5/8	7/8	7/8	7/8
300,000	2 1/8	2 1/8	2 1/8	2 5/8	2 1/8	2 5/8	3 1/8	3 1/8	7/8	7/8	1 1/8	1 1/8
360,000	2 1/8	2 1/8	2 5/8	2 5/8	2 5/8	2 5/8	3 1/8	3 1/8	7/8	7/8	1 1/8	1 1/8
480,000	2 1/8	2 5/8	2 5/8	2 5/8					7/8	1 1/8	1 1/8	1 1/8
600,000	2 1/8	2 5/8	3 1/8	3 1/8					7/8	1 1/8	1 1/8	1 3/8
720,000	2 5/8	3 1/8	3 1/8	3 1/8					7/8	1 1/8	1 1/8	1 3/8
840,000	2 5/8	3 1/8	3 1/8	3 5/8					1 1/8	1 1/8	1 3/8	1 3/8
960,000	2 5/8	3 1/8	3 1/8	3 5/8					1 1/8	1 3/8	1 3/8	1 3/8

Line sizes which are shaded indicate the maximum suction line size which may be used for a riser. In no case should the riser exceed the horizontal line size. Properly placed suction traps must be used to insure proper oil return.

**TABLE 1B
RECOMMENDED LINE SIZES FOR R-404A and R-507**

SYSTEM CAPACITY BTU/H	SUCTION LINE SIZE											
	SUCTION TEMPERATURE											
	+20° F Equivalent Suction Line Length				-20° F Equivalent Suction Line Length				Liquid Line Receiver to Expansion Valve			
	25'	50'	75'	100'	25'	50'	75'	100'	25'	50'	75'	100'
R-404A and R-507												
36,000	7/8	1 1/8	1 1/8	1 1/8	1 1/8	1 1/8	1 3/8	1 3/8	1/2	1/2	1/2	1/2
42,000	1 1/8	1 1/8	1 1/8	1 3/8	1 1/8	1 3/8	1 3/8	1 5/8	1/2	1/2	1/2	1/2
48,000	1 1/8	1 1/8	1 3/8	1 3/8	1 1/8	1 3/8	1 3/8	1 5/8	1/2	1/2	1/2	5/8
54,000	1 1/8	1 1/8	1 3/8	1 3/8	1 3/8	1 3/8	1 5/8	1 5/8	1/2	1/2	1/2	5/8
60,000	1 1/8	1 1/8	1 3/8	1 3/8	1 3/8	1 3/8	1 5/8	1 5/8	1/2	1/2	5/8	5/8
66,000	1 1/8	1 3/8	1 3/8	1 3/8	1 3/8	1 5/8	1 5/8	1 5/8	1/2	1/2	5/8	5/8
72,000	1 1/8	1 3/8	1 3/8	1 5/8	1 3/8	1 5/8	1 5/8	1 5/8	1/2	5/8	5/8	5/8
78,000	1 1/8	1 3/8	1 3/8	1 5/8	1 5/8	1 5/8	1 5/8	1 5/8	5/8	5/8	5/8	5/8
84,000	1 1/8	1 3/8	1 5/8	1 5/8	1 5/8	1 5/8	1 5/8	2 1/8	5/8	5/8	5/8	5/8
90,000	1 3/8	1 3/8	1 5/8	1 5/8	1 5/8	1 5/8	2 1/8	2 1/8	5/8	5/8	5/8	7/8
120,000	1 3/8	1 5/8	1 5/8	2 1/8	1 5/8	2 1/8	2 1/8	2 1/8	5/8	5/8	7/8	7/8
150,000	1 5/8	1 5/8	2 1/8	2 1/8	2 1/8	2 1/8	2 1/8	2 5/8	5/8	7/8	7/8	7/8
180,000	1 5/8	2 1/8	2 1/8	2 1/8	2 1/8	2 1/8	2 5/8	2 5/8	7/8	7/8	7/8	7/8
210,000	1 5/8	2 1/8	2 1/8	2 1/8	2 1/8	2 5/8	2 5/8	2 5/8	7/8	7/8	7/8	7/8
240,000	1 5/8	2 1/8	2 1/8	2 1/8	2 1/8	2 5/8	2 5/8	2 5/8	7/8	7/8	1 1/8	1 1/8
300,000	2 1/8	2 1/8	2 5/8	2 5/8	2 5/8	2 5/8	2 5/8	3 1/8	7/8	1 1/8	1 1/8	1 1/8
360,000	2 1/8	2 1/8	2 5/8	2 5/8					1 1/8	1 1/8	1 1/8	1 3/8
480,000	2 1/8	2 5/8	2 5/8	3 1/8					1 1/8	1 1/8	1 3/8	1 3/8
600,000	2 5/8	2 5/8	3 1/8	3 1/8					1 1/8	1 3/8	1 3/8	1 5/8

Line sizes which are shaded indicate the maximum suction line size which may be used for a riser. In no case should the riser exceed the horizontal line size. Properly placed suction traps must be used to insure proper oil return.

**TABLE 2A
SLD CONDENSING UNIT REFRIGERANT CHARGE - POUNDS**

			Above					Below
Model	Refrigerant		70 F	50 F	30 F	10 F	0 F	-20 F
SLD 0100	H2	R-22	29.1	39.8	43.6	45.9	46.8	48.4
SLD 0150	H2	R-22	31.6	37.3	44.8	49.0	50.6	53.1
SLD 0200	H2	R-22	31.6	37.3	44.8	49.0	50.6	53.1
SLD 0250	H2	R-22	42.4	50.7	61.9	68.2	70.5	74.2
SLD 0300	H2	R-22	53.2	64.2	79.0	87.4	90.4	95.3
SLD 0350	H2	R-22	55.7	58.6	71.9	84.0	88.5	95.4
SLD 0400	H2	R-22	72.5	76.0	89.6	101.9	106.6	113.7
SLD 0500	H2	R-22	80.6	97.0	119.3	131.8	136.4	143.7
SLD 0600	H2	R-22	97.1	101.8	120.0	136.4	142.6	152.2
SLD 0101	H2	R-22	31.6	42.4	48.3	51.6	53.0	55.5
SLD 0151	H2	R-22	42.4	58.4	67.1	72.1	74.1	77.8
SLD 0201	H2	R-22	42.4	58.4	67.1	72.1	74.1	77.8
SLD 0251	H2	R-22	42.3	48.0	60.6	67.1	69.5	73.4
SLD 0301	H2	R-22	55.7	63.9	82.7	92.4	95.9	101.7
SLD 0351	H2	R-22	80.4	91.5	116.6	129.7	134.5	142.2
SLD 0401	H2	R-22	91.2	132.9	155.9	168.7	173.8	183.5
SLD 0501	H2	R-22	112.9	129.4	166.9	186.4	193.5	205.0
SLD 0601	H2	R-22	137.0	158.4	208.2	234.0	243.3	258.4
SLD 0220	L2	R-22	31.6	47.5	51.8	54.1	55.2	57.1
SLD 0270	L2	R-22	36.9	60.3	66.6	70.0	71.5	74.1
SLD 0300	L2	R-22	36.9	60.3	66.6	70.0	71.5	74.1
SLD 151	L2	R-22	36.9	60.3	66.6	70.0	71.5	74.1
SLD 0221	L2	R-22	36.9	60.3	66.6	70.0	71.5	74.1
SLD 0271	L2	R-22	36.8	53.8	62.1	54.9	68.4	71.4
SLD 0301	L2	R-22	50.2	75.6	87.9	77.0	97.3	101.6
SLD 0150	M4	R-404A	27.9	33.4	40.2	44.2	45.7	48.1
SLD 0200	M4	R-404A	27.9	33.4	40.2	44.2	45.7	48.1
SLD 0250	M4	R-404A	37.4	45.4	55.6	61.5	63.6	67.1
SLD 0300	M4	R-404A	46.9	57.4	70.9	78.7	81.6	86.1
SLD 0350	M4	R-404A	42.2	45.0	53.3	60.9	63.8	68.2
SLD 0400	M4	R-404A	70.8	75.7	91.9	106.8	112.5	121.0
SLD 0151	M4	R-404A	37.4	52.1	60.2	64.9	66.8	70.3
SLD 0201	M4	R-404A	37.4	52.1	60.2	64.9	66.8	70.3
SLD 0251	M4	R-404A	49.0	57.1	74.1	83.2	86.5	91.8
SLD 0301	M4	R-404A	63.9	72.9	90.2	99.6	103.1	108.7
SLD 0351	M4	R-404A	71.0	100.2	116.3	125.7	129.4	136.4
SLD 0401	M4	R-404A	95.1	134.1	155.6	168.1	173.1	182.4
SLD 0220	L4	R-404A	29.3	37.9	43.3	46.6	47.9	50.3
SLD 0270	L4	R-404A	39.5	52.1	60.2	64.9	66.8	70.3
SLD 0300	L4	R-404A	44.8	61.2	71.8	77.9	80.4	84.9
SLD 0221	L4	R-404A	39.5	58.9	64.8	68.3	69.8	72.4
SLD 0271	L4	R-404A	39.4	53.1	60.9	54.9	67.1	70.0
SLD 0301	L4	R-404A	52.2	72.4	83.9	74.7	93.0	97.1

**TABLE 2B
DLD CONDENSING UNIT REFRIGERANT CHARGE – POUNDS**

			Above					Below	
Model*			Refrigerant	70 F	50 F	30 F	10 F	0 F	-20 F
DLD	0100	H2	R-22	14.7	18.5	19.8	20.7	21.0	21.6
DLD	0150	H2	R-22	17.4	24.5	27.0	28.5	29.0	30.0
DLD	0160	H2	R-22	17.3	20.2	24.0	26.1	26.9	28.2
DLD	0180	H2	R-22	17.3	20.2	24.0	26.1	26.9	28.2
DLD	0200	H2	R-22	29.0	33.4	39.1	42.4	43.6	45.6
DLD	0240	H2	R-22	31.6	37.3	44.8	49.0	50.6	53.1
DLD	0300	H2	R-22	32.9	34.5	41.2	47.3	49.6	53.2
DLD	0400	H2	R-22	32.9	34.5	41.2	47.3	49.6	53.2
DLD	0500	H2	R-22	42.3	44.4	53.4	61.5	64.6	69.2
DLD	0600	H2	R-22	53.2	64.2	79.0	87.4	90.4	95.3
DLD	0700	H2	R-22	55.7	58.6	71.9	84.0	88.5	95.4
DLD	0800	H2	R-22	80.4	84.5	102.3	118.5	124.6	133.8
DLD	1000	H2	R-22	80.3	83.9	89.7	109.1	117.5	126.4
DLD	1200	H2	R-22	104.8	108.7	110.6	130.4	144.0	155.1
DLD	0101	H2	R-22	17.4	26.0	28.0	29.3	29.8	30.7
DLD	0151	H2	R-22	17.3	22.7	25.7	27.4	28.1	29.4
DLD	0161	H2	R-22	20.0	27.9	32.3	34.7	35.7	37.5
DLD	0181	H2	R-22	31.6	42.4	48.3	51.6	53.0	55.5
DLD	0201	H2	R-22	32.9	37.1	46.6	51.6	53.4	56.3
DLD	0241	H2	R-22	32.9	37.1	46.6	51.6	53.4	56.3
DLD	0301	H2	R-22	42.3	48.0	60.6	67.1	69.5	73.4
DLD	0401	H2	R-22	42.4	58.4	67.1	72.1	74.1	77.8
DLD	0501	H2	R-22	42.3	48.0	60.6	67.1	69.5	73.4
DLD	0601	H2	R-22	55.7	63.9	82.7	92.4	95.9	101.7
DLD	0701	H2	R-22	80.4	91.5	116.6	129.7	134.5	142.2
DLD	0801	H2	R-22	90.8	95.9	126.1	145.9	152.3	164.1
DLD	1001	H2	R-22	117.9	122.3	147.4	176.9	1067.7	203.1
DLD	1201	H2	R-22	136.6	141.6	157.9	198.1	209.5	231.5
DLD	0440	L2	R-22	23.9	36.5	42.7	37.2	47.3	49.4
DLD	0540	L2	R-22	27.8	44.5	52.6	45.3	58.7	61.5
DLD	0600	L2	R-22	36.9	60.3	66.6	70.0	71.5	74.1
DLD	0441	L2	R-22	27.8	44.5	52.6	45.3	58.7	61.5
DLD	0541	L2	R-22	33.2	63.8	71.9	76.1	78.0	81.2
DLD	0601	L2	R-22	44.7	69.9	82.1	71.1	91.3	95.5
DLD	0400	M4	R-404A	29.0	30.9	37.1	42.7	44.9	48.1
DLD	0500	M4	R-404A	37.3	39.8	48.0	55.5	58.4	62.7
DLD	0600	M4	R-404A	46.9	57.4	70.9	78.7	81.6	86.1
DLD	0700	M4	R-404A	42.2	45.0	53.3	60.9	63.8	68.2
DLD	0800	M4	R-404A	70.8	75.7	91.9	106.8	112.5	121.0
DLD	0401	M4	R-404A	37.4	52.1	60.2	64.9	66.8	70.3
DLD	0501	M4	R-404A	49.0	51.7	74.1	83.2	86.5	91.8
DLD	0601	M4	R-404A	63.9	72.9	90.2	99.6	103.1	108.7
DLD	0701	M4	R-404A	70.7	75.8	96.5	110.4	115.0	123.4
DLD	0801	M4	R-404A	94.7	101.5	129.2	147.7	153.9	165.0
DLD	0440	L4	R-404A	30.5	33.3	41.9	46.5	48.2	51.0
DLD	0540	L4	R-404A	39.4	42.9	54.4	60.5	62.8	66.4
DLD	0600	L4	R-404A	39.5	52.1	60.2	64.9	66.8	70.3
DLD	0441	L4	R-404A	39.5	58.9	64.8	68.3	69.8	72.4
DLD	0541	L4	R-404A	44.8	70.2	78.0	82.4	84.3	87.6
DLD	0601	L4	R-404A	52.2	72.4	83.9	74.7	93.0	97.1

* All units have two refrigerant circuits. Refrigerant charge shown is per circuit.

**TABLE 2C
PLD CONDENSING UNIT REFRIGERANT CHARGE - POUNDS**

			Above					Below	
Model		Refrigerant	70 F	50 F	30 F	10 F	0 F	-20 F	
PLD	0500	H2	R-22	80.4	84.5	102.3	118.5	124.6	133.8
PLD	0600	H2	R-22	107.9	129.9	159.7	176.3	182.4	192.2
PLD	0700	H2	R-22	112.9	118.8	145.4	169.5	178.6	192.4
PLD	0800	H2	R-22	160.7	168.9	204.6	236.9	249.1	267.7
PLD	1000	H2	R-22	160.5	167.8	179.5	218.3	235.0	252.8
PLD	1200	H2	R-22	144.1	149.5	152.1	190.6	217.3	238.3
PLD	0501	H2	R-22	80.4	91.5	116.6	129.7	134.5	142.2
PLD	0601	H2	R-22	112.9	129.4	166.9	186.4	193.5	205.0
PLD	0701	H2	R-22	137.0	158.4	208.2	234.0	243.3	258.4
PLD	0801	H2	R-22	181.5	191.9	252.3	291.7	304.7	328.2
PLD	1001	H2	R-22	170.3	176.7	225.6	283.6	2064.8	334.3
PLD	1201	H2	R-22	199.4	206.8	237.9	317.1	339.3	382.1
PLD	0440	L2	R-22	44.7	69.9	82.1	71.1	91.3	95.5
PLD	0540	L2	R-22	52.6	85.9	102.1	87.3	114.2	119.7
PLD	0600	L2	R-22	58.3	104.5	116.8	123.3	126.2	131.2
PLD	0441	L2	R-22	52.6	85.9	102.1	87.3	114.2	119.7
PLD	0541	L2	R-22	63.4	124.5	140.6	149.1	152.8	159.1
PLD	0601	L2	R-22	73.9	123.6	147.9	125.6	165.9	174.1
PLD	0500	M4	R-404A	70.8	75.7	91.9	106.8	112.5	121.0
PLD	0600	M4	R-404A	95.1	116.1	143.2	158.8	164.6	173.7
PLD	0700	M4	R-404A	85.7	91.4	108.0	123.2	129.1	137.9
PLD	0800	M4	R-404A	141.6	151.4	183.9	213.6	225.0	242.1
PLD	0501	M4	R-404A	99.4	115.7	149.6	167.8	174.5	185.2
PLD	0601	M4	R-404A	106.7	123.4	157.6	175.9	182.7	193.5
PLD	0701	M4	R-404A	141.4	149.2	193.0	220.8	230.1	246.8
PLD	0801	M4	R-404A	159.6	171.6	226.1	262.5	274.6	296.3
PLD	0440	L4	R-404A	52.2	57.1	74.1	83.2	86.5	91.8
PLD	0540	L4	R-404A	75.0	81.9	104.6	116.9	121.4	128.6
PLD	0600	L4	R-404A	75.2	100.2	116.3	125.7	129.4	136.4
PLD	0441	L4	R-404A	75.2	113.7	125.6	132.4	135.4	140.5
PLD	0541	L4	R-404A	100.7	152.1	167.9	177.0	181.0	187.9
PLD	0601	L4	R-404A	105.7	146.3	169.3	150.9	187.5	195.8

**TABLE 3A
LOW PRESSURE CONTROL SETTINGS**

Minimum + Temperature	R-22		R-404A	
	Max Cut In	Cut Out	Max Cut In	Cut Out
50 F	70 Psig	30 Psig	85 Psig	40 Psig
40 F	55 Psig	25 Psig	70 Psig	35 Psig
30 F	40 Psig	20 Psig	50 Psig	30 Psig
20 F	30 Psig	10 Psig	40 Psig	20 Psig
10 F	20 Psig	5 Psig	30 Psig	10 Psig
0 F	15 Psig	0 Psig	25 Psig	5 Psig
-10 F	10 Psig	0 Psig	15 Psig	0 Psig
-20 F	8 Psig	0 Psig	10 Psig	0 Psig

+ Temperature is the minimum ambient temperature at the condensing unit or the box design temperature, whichever is lower.
 Example #1: 30 F minimum ambient, -20 F freezer. Use -20 F value from Table.
 Example #2: -10 F minimum ambient, +35 F cooler. Use -10 F value from Table.

**TABLE 3B
HIGH PRESSURE CONTROL SETTINGS**

R-22	400 Psig
R-404A/R-507	400 Psig

**TABLE 4
FAN CYCLING CONTROL SETTINGS**

Number of Fans		Refrigerant	<u>Control Cut In Settings-PSIG</u>			
Single Row	Double Row		FCP-1	FCP-2	FCP-3	FCP-4
2	4	R-22	215			
		R-404A	220			
3	6	R-22	215	230		
		R-404A	220	245		
4	8	R-22	215	230	245	
		R-404A	220	245	265	
5	10	R-22	215	225	235	245
		R-404A	220	235	250	265

Note: Settings based on 20 TD. Set cut out 35 psig below cut in. Fan(s) on header end to remain on at all times.