

# Cube Evaporative Condenser

BTC FORCED DRAFT MODELS



## Cube Blow-Through Evaporative Condenser

The Cube represents the synergy derived from combining the efforts and strengths of two companies to create better solutions for the refrigeration industry.

Cube Evaporative Condensers are the result of a unique collaboration between SPX Cooling Technologies, Inc. and SGS Refrigeration, Inc. By capitalizing on the unique capabilities and strengths of two companies, Cube Evaporative Condensers offer customers several advantages:

- **ROBUST CONSTRUCTION**

Strong galvanized steel houses high quality mechanical and heat transfer systems. Stainless steel component options allow customization to address the most demanding environmental and service life requirements.

- **RESPONSIVENESS**

There are numerous evaporative condensers available that can meet your design and performance criteria. What separates the field is the level of service you can expect from your supplier. From specification review, product selection assistance and on-time delivery to installation coordination and ongoing operational support, SGS Refrigeration's customer service and sales teams provide an extra measure of attention, know-how and commitment to your satisfaction.



- **PARTNERSHIP**

SGS Refrigeration and SPX Cooling Technologies capitalized on their unique capabilities to produce and sell refrigeration products with more value for our customers. Cube Evaporative Condensers take advantage of the engineering and production strengths of our two independent companies as well as the shared business philosophy that meeting customer expectations is paramount to long term success. Customers benefit from the partnership in two ways: the Cube is a well-engineered, robust and reliable product; and the partners are committed to customer satisfaction throughout the life of the product.

### **BLOW-THROUGH (FORCED DRAFT) MODELS**

Choose from a broad selection of BTC models in 10' and 12' nominal widths and four nominal lengths from 12' to 36' to meet your specific refrigeration requirements.

### **UPDATE™ PROPRIETARY PRODUCT SELECTION SOFTWARE**

The UPDATE product software takes the guesswork out of product selection and helps specifiers of refrigeration systems evaluate several product configurations and criteria in order to make informed choices.

### **MANUFACTURED IN AMERICA**

The Cube Evaporative Condenser is totally fabricated and assembled at SPX and SGS manufacturing plants in the U.S. From tube production and bending, welding, parts fabrication and assembly, condenser components are produced, inspected, assembled and performance-tested to our high standards of quality.

### **NATIONWIDE SUPPORT**

The SGS network of sales and service specialists are ready to provide you the most responsive and knowledgeable airside refrigeration products support across the United States. Rely on us for expert selection, installation and operational assistance. Visit [sgsrefrigeration.com](http://sgsrefrigeration.com) to locate your SGS technical representative.

**STRONG GALVANIZED STEEL CONSTRUCTION**

The high quality mechanical components and refrigeration coils are safely housed in heavy-duty galvanized steel to ensure corrosion protection, low maintenance and long life. Submerged areas are bolted or welded to minimize potential for leaks; tap screws are not used in submerged areas.

**STAINLESS STEEL OPTIONS**

When environmental and design conditions dictate, heavy gauge stainless steel water collection basins and other structural components may be specified.

**CLOG-RESISTANT WATER DISTRIBUTION SYSTEM**

Self-draining spray headers and large orifice spray nozzles help prevent debris build-up and clogging. Self-draining spray headers limit potential ice buildup when not operational; spray nozzles mount to the bottom of the spray pipes.

**LARGE ACCESS DOORS**

Located on opposite walls, the rectangular doors provide easy access to the inside of the unit.

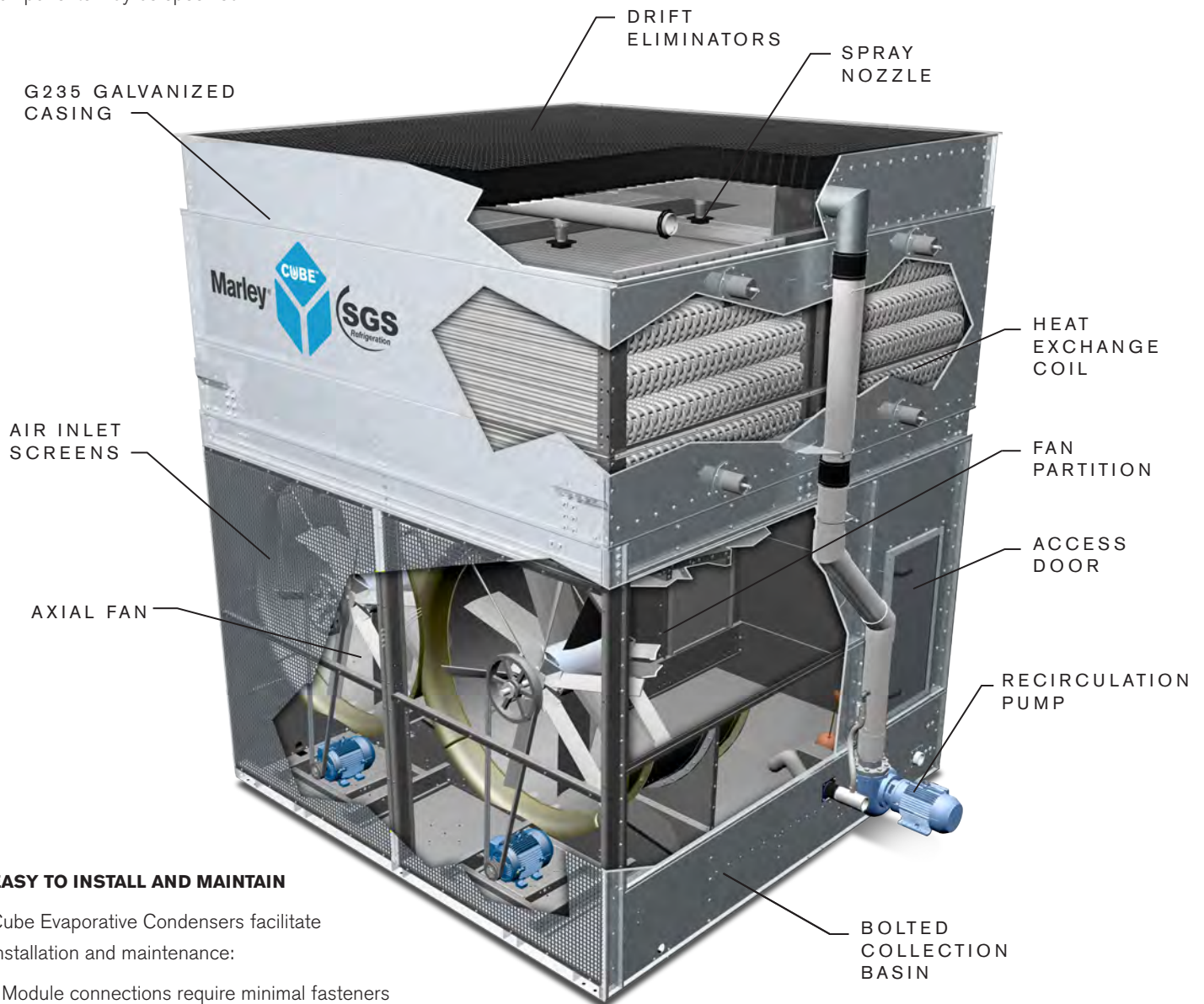

**EASY TO INSTALL AND MAINTAIN**

Cube Evaporative Condensers facilitate installation and maintenance:

- Module connections require minimal fasteners
- Pre-assembled platform options have welded guardrails

### **Access Platforms**

Condenser-supported upper access platforms are available in a variety of configurations. Platforms can be configured on one or more faces of the condenser, excluding coil/pipe connection face(s). Corner connectors can be selected to connect platforms on adjacent sides of the condenser, enabling ladder consolidation. Platform surfaces are surrounded by a guardrail, kneerail and toeboard designed according to OSHA guidelines. Partial factory assembled platforms are available to simplify field installation. Available platform accessories include ladder(s), ladder extension(s), safety cage(s) and safety gate(s).

### **Remote Sump Application**

For applications with remote sump, the condenser recirculating water pump and piping are removed and an outlet connection is added in the collection basin.

### **One Motor - Two Fans**

The standard BTC drive arrangement incorporates a single NEMA premium efficiency, TEFC inverter duty motor driving each fan through a system of belts and pulleys. For replacement applications where extensive electrical service modifications are not practical, the fan drive system can be optionally configured to drive two fans from a single motor.

### **Vibration Switch**

A mechanical vibration switch may be factory mounted for wiring to the shutdown circuit of the fan motor(s) starter or VFD. The switch is designed to interrupt control power voltage to a safety circuit in the event of excessive vibration causing the starter or VFD equipment to de-energize the motor(s).

### **Ultra Quiet Fans**

For applications requiring reduced condenser sound levels, Ultra Quiet fans may be employed to reduce air inlet sound levels up to 12 dBA. Fans are propeller-type, incorporating wide-chord acoustic geometry, individually adjustable, corrosion and fire resistant marine grade aluminum blades resiliently mounted to an aluminum hub.

### **Stainless Steel Construction**

When an enhanced level of corrosion protection is desired, condensers may be configured with varying levels of stainless steel construction. Stainless steel collection basins, welded and factory water tested to reduce the potential for leaks, are a commonly selected upgrade. Units with stainless steel collection basin and casing are also available.

### **Electronic Water Level Control**

An electronic water level control system consisting of a NEMA 4X control panel, water level probes and probe stilling chamber may be selected to monitor the water level in the collection basin to determine level events used for makeup, high/low alarm(s), and/or pump shutdown.

### **Water Level Standpipe**

An external water level standpipe is available to allow visual determination of the basin water level from the exterior of the unit while in operation.

### **Pump Heat Trace**

When an electric basin heater package is selected, the recirculating pump(s) may be fitted with electric heat trace cable and insulated to protect the water retained in the pump from freezing during periods of shutdown or standby operation.

### **Basin Sweeper Piping**

As an option to augment an external filtration system, the collection basin may be equipped with a factory installed corrosion resistant sweeper piping system designed to force dirt and debris towards a dedicated drain in the depressed section of the collection basin.

**MODEL NOMENCLATURE**

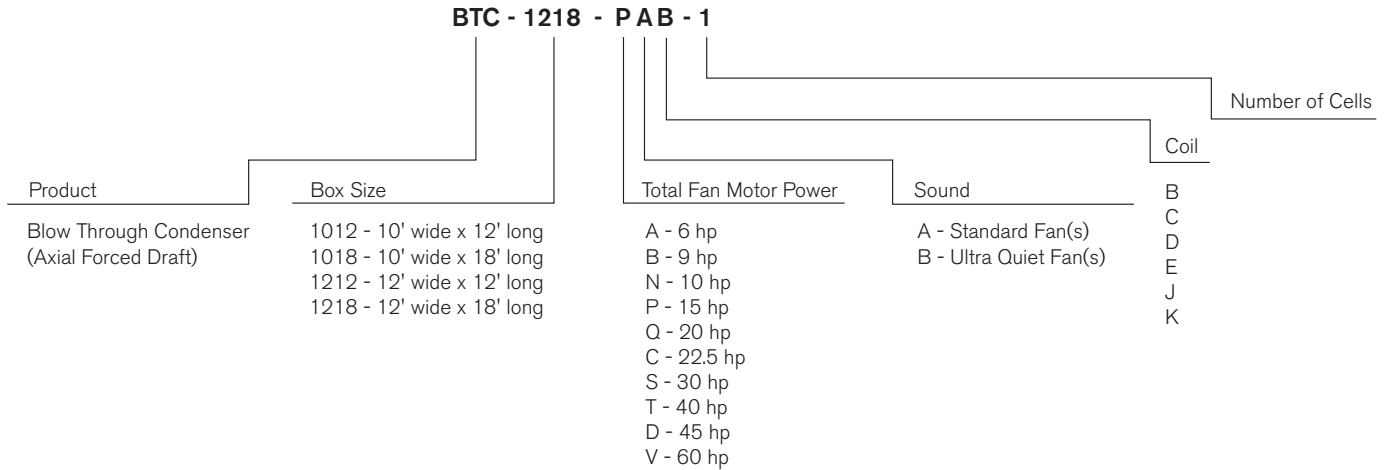

**HEAT REJECTION METHOD**

There are several commonly used methods for selecting an evaporative condenser as part of a mechanical refrigeration system. The most accurate method sizes a condenser based on the Total Heat Rejection required at a given condensing duty. Total Heat Rejection is defined as the sum of the heat input at the evaporator and the energy input at the compressor.

**1. Establish the Design Duty**

- a. Refrigerant
- b. Condensing Temperature - °F
- c. Wet-Bulb Temperature - °F
- d. Total Heat Rejection required - MBH

**Open Compressors:**

$$\text{THR (MBH)} = \text{Compressor Evaporator Capacity (MBH)} + \text{Compressor Power (bhp)} \times 2.545$$

**Hermetic Compressors:**

$$\text{THR (MBH)} = \text{Compressor Evaporator Capacity (MBH)} + \text{Compressor Input (kW)} \times 3.415$$

- Note:
- 1 MBH = 1000 Btu/hr
  - 1 Ton = 12 MBH
  - 1 kW = 3.415 MBH
  - 1 hp = 2.545 MBH
  - 1 kW = 1.341 hp
  - 1 °F = 1.8 °C + 32

**2. Determine the Heat Rejection Capacity Factor**

- a. Select the appropriate Heat Rejection Capacity Factor table based on the system Refrigerant.
  - 1. **Table 2** – Ammonia R717
  - 2. **Table 3** – HFC and HCFC

- b. Find the Heat Rejection Capacity Factor corresponding to the design Condensing Temperature and design Wet-Bulb Temperature.

**3. Calculate the Corrected Heat Rejection**

Multiply the Total Heat Rejection from **Step 1** by the Heat Rejection Capacity Factor from **Step 2** to obtain the Corrected Heat Rejection.

**4. Select an Evaporative Condenser Model**

Select an Evaporative Condenser model with a Base Heat Rejection **Table 1** greater than or equal to the Corrected Heat Rejection calculated in **Step 3**. If the Corrected Heat Rejection exceeds table values, multiple cells are required.



Model	Base Heat Rejection MBH	Model	Base Heat Rejection MBH	Model	Base Heat Rejection MBH	Model	Base Heat Rejection MBH
BTC-1012-AAB1	3,875.6	BTC-1212-AAB1	4,439.0	BTC-1018-BAB1	5,947.9	BTC-1218-BAB1	7,233.0
BTC-1012-NAB1	4,414.3	BTC-1212-NAB1	5,027.4	BTC-1018-PAB1	6,776.9	BTC-1218-PAB1	7,732.2
BTC-1012-PAB1	4,870.3	BTC-1212-PAB1	5,541.9	BTC-1018-CAB1	7,460.8	BTC-1218-CAB1	8,540.7
BTC-1012-QAB1	5,201.8	BTC-1212-QAB1	5,939.0	BTC-1018-SAB1	7,999.7	BTC-1218-SAB1	9,158.4
BTC-1012-NAC1	4,994.7	BTC-1212-NAC1	5,601.0	BTC-1018-PAC1	7,502.5	BTC-1218-PAC1	8,555.0
BTC-1012-PAC1	5,512.9	BTC-1212-PAC1	6,174.0	BTC-1018-CAC1	8,248.6	BTC-1218-CAC1	9,437.4
BTC-1012-QAC1	5,906.6	BTC-1212-QAC1	6,629.7	BTC-1018-SAC1	8,828.9	BTC-1218-SAC1	10,113.8
BTC-1012-PAD1	5,595.8	BTC-1212-PAD1	6,445.5	BTC-1018-CAD1	8,600.9	BTC-1218-CAD1	9,761.0
BTC-1012-QAD1	5,989.5	BTC-1212-QAD1	6,923.7	BTC-1018-SAD1	9,119.0	BTC-1218-SAD1	10,452.0
BTC-1012-NAJ1	5,567.0	BTC-1212-SAD1	7,541.1	BTC-1018-PAJ1	8,435.1	BTC-1218-DAD1	11,540.0
BTC-1012-PAJ1	5,906.6	BTC-1212-QAJ1	7,217.7	BTC-1018-CAJ1	8,953.2	BTC-1218-SAJ1	11,025.0
BTC-1012-QAJ1	6,321.1	BTC-1212-SAJ1	7,953.0	BTC-1018-DAJ1	10,694.1	BTC-1218-DAJ1	12,157.0
BTC-1012-SAJ1	6,963.6	BTC-1212-TAJ1	8,526.0	BTC-1018-CAE1	9,243.4	BTC-1218-VAJ1	13,039.0
BTC-1012-PAE1	6,031.0	BTC-1212-PAE1	6,963.6	BTC-1018-SAE1	9,865.1	BTC-1218-CAE1	10,528.3
BTC-1012-QAE1	6,466.2	BTC-1212-QAE1	7,481.7	BTC-1018-PAK1	8,580.2	BTC-1218-SAE1	11,295.1
BTC-1012-NAK1	5,782.3	BTC-1212-SAE1	8,144.9	BTC-1018-CAK1	9,575.0	BTC-1218-DAE1	12,455.7
BTC-1012-PAK1	6,362.6	BTC-1212-QAK1	7,894.0	BTC-1018-SAK1	10,404.0	BTC-1218-CAK1	11,937.6
BTC-1012-QAK1	6,818.5	BTC-1212-SAK1	8,599.5	BTC-1018-DAK1	11,460.9	BTC-1218-SAK1	13,156.5
BTC-1012-SAK1	7,543.9	BTC-1212-TAK1	9,202.2			BTC-1218-DAK1	13,156.5
						BTC-1218-VAK1	14,067.9

**Table 1** Base Heat Rejection

Table data is per cell. For multiple cell selections, multiply Base Heat Rejection by number of cells.

**EXAMPLE** Evaporative Condenser Selection

Design Duty	
Refrigerant	Ammonia
Wet-Bulb Temperature	78°F
Condensing Temperature	96.3°F
Compressor Evaporator Capacity	350 Tons
Compressor Power	400 bhp

The **Total Heat Rejection**, THR, is calculated using the formula for open compressors. 350 Tons x 12 MBH/Ton + 400 bhp  
 2,545 MBH/BHP = 5218 MBH.

From the **Ammonia** Refrigerant Capacity Factor **Table 2**, at a 78°F **Wet-Bulb Temperature** and a 96.3°F **Condensing Temperature**, the **Heat Rejection Capacity Factor** is 1.37.

Calculations	
Total Heat Rejection	5218 MBH
Capacity Factor	1.37
Corrected Heat Rejection	7148.7 MBH
Model Selection	BTC-1012-SAK1

Multiplying the **Total Heat Rejection** of 5218 MBH by 1.37 yields a **Corrected Heat Rejection** of 7148.7 MBH. **BTC-1012-SAK1** is the smallest Model Selection with a Base Heat Rejection **Table 1** greater than 7148.7 MBH.

Ammonia R717 Heat Rejection Capacity Factors																		
Condensing Pressure psig		Condensing Temperature °F	Entering Wet-Bulb Temperature °F															
			50	52	54	56	58	60	62	64	66	68	70	72	74	76	78	80
R717																		
151.3	85	0.98	1.02	1.06	1.12	1.18	1.25	1.33	1.43	1.56	1.71	1.90	2.15	2.49	2.99	3.77	-	-
154.1	86	0.94	0.98	1.03	1.07	1.13	1.20	1.27	1.36	1.47	1.60	1.77	1.99	2.27	2.68	3.28	-	-
156.9	87	0.91	0.95	0.99	1.03	1.09	1.15	1.22	1.30	1.39	1.51	1.66	1.85	2.09	2.42	2.90	3.66	-
159.8	88	0.88	0.92	0.95	1.00	1.04	1.10	1.16	1.24	1.33	1.43	1.56	1.72	1.93	2.21	2.60	3.19	-
162.6	89	0.86	0.89	0.92	0.96	1.01	1.06	1.11	1.18	1.26	1.36	1.47	1.61	1.79	2.03	2.35	2.82	3.56
165.5	90	0.83	0.86	0.89	0.93	0.97	1.02	1.07	1.13	1.20	1.29	1.39	1.52	1.67	1.88	2.15	2.53	3.10
168.5	91	0.81	0.83	0.86	0.90	0.94	0.98	1.03	1.08	1.15	1.23	1.32	1.43	1.57	1.75	1.98	2.29	2.74
171.5	92	0.78	0.81	0.84	0.87	0.90	0.94	0.99	1.04	1.10	1.17	1.25	1.35	1.48	1.63	1.83	2.09	2.46
174.5	93	0.76	0.78	0.81	0.84	0.87	0.91	0.95	1.00	1.05	1.12	1.19	1.28	1.39	1.53	1.70	1.92	2.23
177.6	94	0.74	0.76	0.79	0.81	0.85	0.88	0.92	0.96	1.01	1.07	1.14	1.22	1.32	1.44	1.58	1.78	2.03
180.7	95	0.72	0.74	0.76	0.79	0.82	0.85	0.89	0.93	0.97	1.03	1.09	1.16	1.25	1.35	1.49	1.65	1.87
185.0	96.3	0.69	0.71	0.74	0.76	0.79	0.81	0.85	0.88	0.93	0.97	1.03	1.09	1.17	1.26	1.37	1.51	1.69
187.0	97	0.68	0.70	0.72	0.74	0.77	0.80	0.83	0.86	0.90	0.95	1.00	1.06	1.13	1.22	1.32	1.45	1.61
190.2	98	0.66	0.68	0.70	0.72	0.75	0.77	0.80	0.83	0.87	0.91	0.96	1.01	1.08	1.16	1.25	1.36	1.50
193.4	99	0.65	0.66	0.68	0.70	0.72	0.75	0.78	0.81	0.84	0.88	0.92	0.97	1.03	1.10	1.18	1.28	1.41
196.7	100	0.63	0.65	0.66	0.68	0.70	0.73	0.75	0.78	0.81	0.85	0.89	0.93	0.99	1.05	1.12	1.21	1.32
213.7	105	0.56	0.57	0.58	0.60	0.61	0.63	0.65	0.67	0.69	0.72	0.74	0.78	0.81	0.85	0.90	0.95	1.02
231.8	110	0.50	0.51	0.52	0.53	0.54	0.55	0.57	0.58	0.60	0.62	0.64	0.66	0.68	0.71	0.74	0.78	0.82

**Table 2** Ammonia R717 Heat Rejection Capacity Factors

HFC and HCFC Heat Rejection Capacity Factors																			
Condensing Pressure psig		Condensing Temperature °F	Entering Wet-Bulb Temperature °F																
			50	52	54	56	58	60	62	64	66	68	70	72	74	76	78	80	82
R404A	R507A																		
189.5	193.9	85	1.09	1.13	1.19	1.25	1.31	1.39	1.49	1.60	1.74	1.90	2.12	2.40	2.78	3.33	-	-	-
192.4	196.8	86	1.05	1.09	1.14	1.20	1.26	1.33	1.42	1.52	1.64	1.79	1.97	2.21	2.53	2.98	3.65	4.77	-
195.4	199.8	87	1.02	1.06	1.10	1.15	1.21	1.28	1.35	1.45	1.55	1.69	1.85	2.06	2.33	2.70	3.23	4.07	-
198.4	202.9	88	0.99	1.02	1.06	1.11	1.16	1.23	1.30	1.38	1.48	1.59	1.74	1.92	2.15	2.46	2.90	3.55	4.64
201.4	206.0	89	0.95	0.99	1.03	1.07	1.12	1.18	1.24	1.32	1.41	1.51	1.64	1.80	2.00	2.26	2.62	3.14	3.96
204.4	209.1	90	0.93	0.96	0.99	1.03	1.08	1.13	1.19	1.26	1.34	1.44	1.55	1.69	1.87	2.09	2.39	2.82	3.45
207.5	212.2	91	0.90	0.93	0.96	1.00	1.04	1.09	1.15	1.21	1.28	1.37	1.47	1.59	1.75	1.94	2.20	2.55	3.06
210.7	215.4	92	0.87	0.90	0.93	0.97	1.01	1.05	1.10	1.16	1.23	1.30	1.40	1.51	1.64	1.81	2.03	2.33	2.74
213.8	218.6	93	0.85	0.87	0.90	0.94	0.97	1.01	1.06	1.11	1.18	1.25	1.33	1.43	1.55	1.70	1.89	2.14	2.48
217.0	221.8	94	0.82	0.85	0.88	0.91	0.94	0.98	1.02	1.07	1.13	1.19	1.27	1.36	1.47	1.60	1.76	1.98	2.26
220.2	225.1	95	0.80	0.83	0.85	0.88	0.91	0.95	0.99	1.03	1.08	1.14	1.21	1.29	1.39	1.51	1.65	1.84	2.08
223.5	228.4	96	0.78	0.80	0.83	0.85	0.88	0.92	0.95	1.00	1.04	1.10	1.16	1.23	1.32	1.43	1.56	1.72	1.93
226.8	231.8	97	0.76	0.78	0.80	0.83	0.86	0.89	0.92	0.96	1.00	1.05	1.11	1.18	1.26	1.35	1.47	1.61	1.79
230.1	235.2	98	0.74	0.76	0.78	0.80	0.83	0.86	0.89	0.93	0.97	1.01	1.07	1.13	1.20	1.29	1.39	1.51	1.67
233.5	238.6	99	0.72	0.74	0.76	0.78	0.81	0.83	0.86	0.90	0.93	0.98	1.03	1.08	1.15	1.23	1.32	1.43	1.57
236.9	242.1	100	0.70	0.72	0.74	0.76	0.78	0.81	0.84	0.87	0.90	0.94	0.99	1.04	1.10	1.17	1.25	1.35	1.47
254.3	259.9	105	0.62	0.64	0.65	0.67	0.68	0.70	0.72	0.75	0.77	0.80	0.83	0.86	0.90	0.95	1.00	1.06	1.13
272.7	278.7	110	0.56	0.57	0.58	0.59	0.60	0.62	0.63	0.65	0.67	0.69	0.71	0.73	0.76	0.79	0.83	0.87	0.91

**Table 3** HFC and HCFC Heat Rejection Capacity Factors

10' x 12' Single Cell

Use this data for preliminary layouts only. Obtain current drawing from your sales representative.

*UPDATE™* web-based selection software, available at [spxcooling.com/update](http://spxcooling.com/update) provides Cube model recommendations based on customer's specific design requirements.

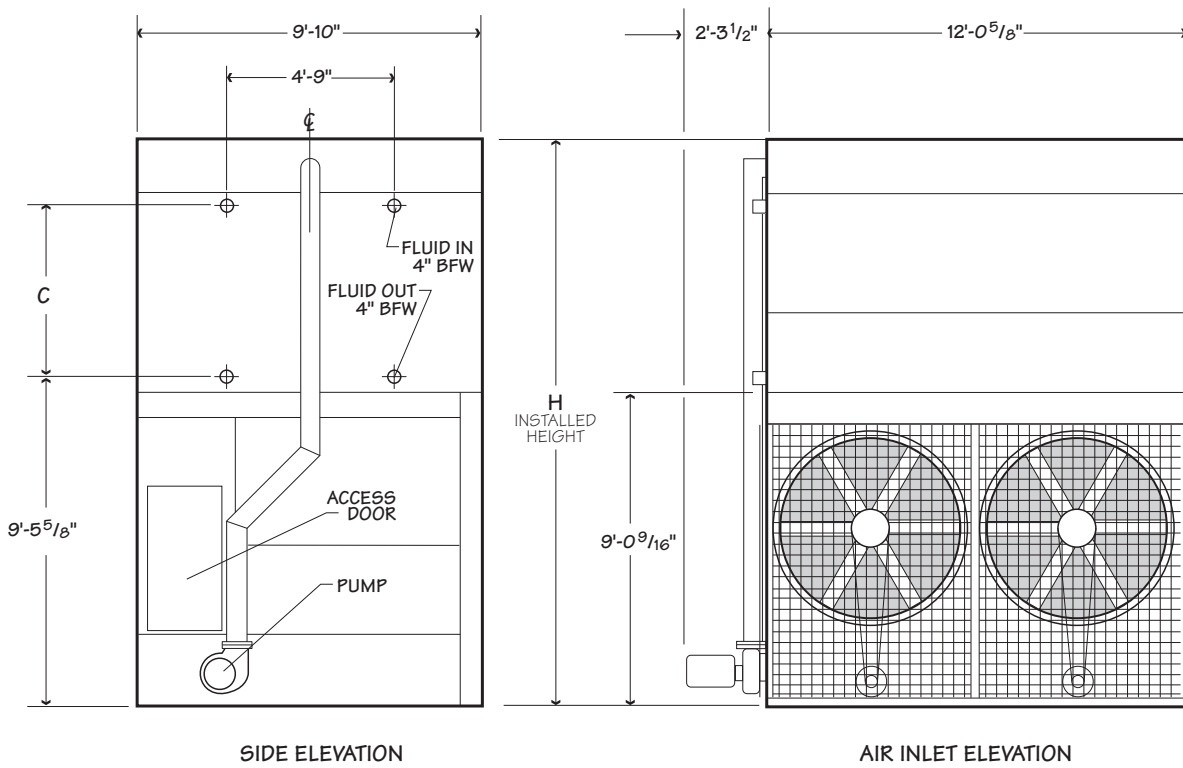



10' x 12' Single Cell

Model note 1	Base Heat Rejection MBH	R717 Capacity tons - note 2	Fan Motor hp	Airflow Rate cfm	Shipping Weight lb		Design Operating Weight lb	Dimensions	
					Weight/Cell	Heaviest Section		H	C
BTC-1012-AAB1	3,875.6	187	2 x 3	46,261	13,800	8,600	18,200	14'-0 <sup>3</sup> / <sub>16</sub> "	2'-8 <sup>1</sup> / <sub>8</sub> "
BTC-1012-NAB1	4,414.3	213	2 x 5	51,822	13,800	8,600	18,200		
BTC-1012-PAB1	4,870.3	235	2 x 7.5	59,260	13,900	8,600	18,300		
BTC-1012-QAB1	5,201.8	251	2 x 10	64,432	13,900	8,600	18,300		
BTC-1012-NAC1	4,994.7	241	2 x 5	51,108	15,400	10,200	19,900	14'-9 <sup>3</sup> / <sub>16</sub> "	3'-5 <sup>1</sup> / <sub>8</sub> "
BTC-1012-PAC1	5,512.9	266	2 x 7.5	58,758	15,500	10,200	20,000		
BTC-1012-QAC1	5,906.6	285	2 x 10	65,670	15,500	10,200	20,000		
BTC-1012-PAD1	5,595.8	270	2 x 5	59,573	17,100	11,800	21,700		
BTC-1012-QAD1	5,989.5	289	2 x 10	65,322	17,100	11,800	21,700	15'-6 <sup>3</sup> / <sub>16</sub> "	4'-2 <sup>1</sup> / <sub>8</sub> "
BTC-1012-NAJ1	5,567.0	269	2 x 5	51,498	18,000	12,800	22,600		
BTC-1012-PAJ1	5,906.6	285	2 x 7.5	58,707	18,100	12,800	22,700		
BTC-1012-QAJ1	6,321.1	305	2 x 10	64,914	18,100	12,800	22,800		
BTC-1012-SAJ1	6,963.6	336	2 x 15	71,900	18,400	12,800	23,000		
BTC-1012-PAE1	6,031.0	291	2 x 7.5	59,108	18,800	13,500	23,400	16'-3 <sup>1</sup> / <sub>16</sub> "	4'-11 <sup>1</sup> / <sub>8</sub> "
BTC-1012-QAE1	6,466.2	312	2 x 10	64,973	18,800	13,500	23,400		
BTC-1012-NAK1	5,782.3	279	2 x 5	50,548	19,800	14,700	24,600		
BTC-1012-PAK1	6,362.6	307	2 x 5	57,936	20,000	14,700	24,700		
BTC-1012-QAK1	6,818.5	329	2 x 10	64,326	20,000	14,700	24,700		
BTC-1012-SAK1	7,543.9	364	2 x 15	71,454	20,200	14,700	24,900		

Model	R717 Charge lb - note 3	Internal Coil Volume ft <sup>3</sup>	Pump Motor hp	Recirculating Flow Rate gpm	Remote Sump Application		
					Approximate Operating Weight lb	Bottom Outlet Diameter	Volume gal
BTC-1012-AAB1	360	36	5	520	17,800	8"	470
BTC-1012-NAB1	360	36			17,800		
BTC-1012-PAB1	360	36			18,000		
BTC-1012-QAB1	360	36			18,000		
BTC-1012-NAC1	444	45			19,500		
BTC-1012-PAC1	444	45			19,600		
BTC-1012-QAC1	444	45			19,600		
BTC-1012-PAD1	529	54			21,300		
BTC-1012-QAD1	529	54			21,300		
BTC-1012-NAJ1	588	60			22,300		
BTC-1012-PAJ1	588	60			22,400		
BTC-1012-QAJ1	588	60			22,400		
BTC-1012-SAJ1	588	60			22,600		
BTC-1012-PAE1	614	62			23,100		
BTC-1012-QAE1	614	62			23,100		
BTC-1012-NAK1	683	69			24,200		
BTC-1012-PAK1	683	69			24,300		
BTC-1012-QAK1	683	69			24,300		
BTC-1012-SAK1	683	69	24,600				

NOTE

- The last digit of the model number shown represents the number of cells.
- R717 tons are at 96.3°F condensing temperature, a 20°F suction temperature and a 78°F entering wet-bulb temperature.
- For R134a charge, multiply by 1.98. For R22 charge multiply by 1.93. For R404A or R507A charge multiply by 1.65.
- Use this bulletin for preliminary layouts only.** Obtain current drawings from your sales representative.

10' x 18' Single Cell

Use this data for preliminary layouts only. Obtain current drawing from your sales representative.

*UPDATE™* web-based selection software, available at [spxcooling.com/update](http://spxcooling.com/update) provides Cube model recommendations based on customer's specific design requirements.

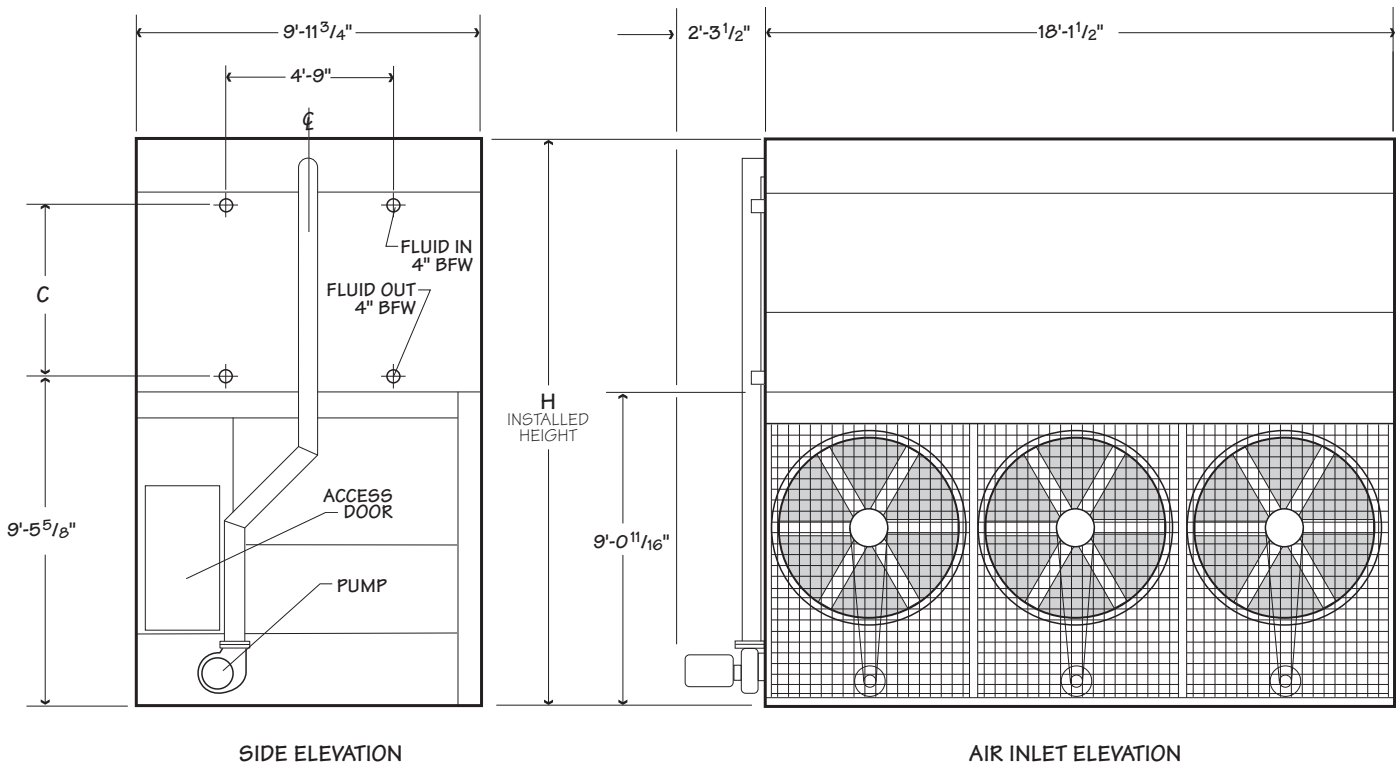

10' x18' Single Cell

Model note 1	Base Heat Rejection MBH	R717 Capacity tons - note 2	Fan Motor hp	Airflow Rate cfm	Shipping Weight lb		Design Operating Weight lb	Dimensions	
					Weight/Cell	Heaviest Section		H	C
BTC-1018-BAB1	5,947.9	287	3 x 3	70,667	19,300	12,100	25,800	14'-0 <sup>1</sup> / <sub>8</sub> "	2'-8 <sup>1</sup> / <sub>8</sub> "
BTC-1018-PAB1	6,776.9	327	3 x 5	79,362	19,300	12,100	25,900		
BTC-1018-CAB1	7,460.8	360	3 x 7.5	92,536	19,500	12,100	26,000		
BTC-1018-SAB1	7,999.7	386	3 x 10	100,991	19,500	12,100	26,100		
BTC-1018-PAC1	7,502.5	362	3 x 5	81,595	21,800	14,600	28,500	14'-9 <sup>1</sup> / <sub>8</sub> "	3'-5 <sup>1</sup> / <sub>8</sub> "
BTC-1018-CAC1	8,248.6	398	3 x 7.5	91,837	22,000	14,600	28,700		
BTC-1018-SAC1	8,828.9	426	3 x 10	100,452	22,000	14,600	28,700		
BTC-1018-CAD1	8,600.9	415	3 x 7.5	91,125	24,300	16,900	31,100	15'-6 <sup>1</sup> / <sub>8</sub> "	4'-2 <sup>1</sup> / <sub>8</sub> "
BTC-1018-SAD1	9,119.0	440	3 x 10	99,916	24,300	16,900	31,200		
BTC-1018-PAJ1	8,435.1	407	3 x 5	78,729	25,600	18,400	32,600		
BTC-1018-CAJ1	8,953.2	432	3 x 7.5	89,775	25,800	18,400	32,700		
BTC-1018-SAJ1	9,616.4	464	3 x 10	99,256	25,800	18,400	32,800		
BTC-1018-DAJ1	10,694.1	516	3 x 15	110,050	26,200	18,400	33,100		
BTC-1018-CAE1	9,243.4	446	3 x 7.5	90,404	26,800	19,400	33,700	16'-3 <sup>1</sup> / <sub>8</sub> "	4'-11 <sup>1</sup> / <sub>8</sub> "
BTC-1018-SAE1	9,865.1	476	3 x 10	99,378	26,800	19,400	33,700		
BTC-1018-PAK1	8,580.2	414	3 x 5	75,000	28,300	21,100	35,400		
BTC-1018-CAK1	9,575.0	462	3 x 7.5	88,608	28,500	21,100	35,600		
BTC-1018-SAK1	10,404.0	502	3 x 10	98,362	28,500	21,100	35,600		
BTC-1018-DAK1	11,460.9	553	3 x 15	109,371	28,900	21,100	35,900		

Model	R717 Charge lb - note 3	Internal Coil Volume ft <sup>3</sup>	Pump Motor hp	Recirculating Flow Rate gpm	Remote Sump Application		
					Approximate Operating Weight lb	Bottom Outlet Diameter	Volume gal
BTC-1018-BAB1	532	54	75	790	25,000	10"	660
BTC-1018-PAB1	532	54			25,000		
BTC-1018-CAB1	532	54			25,200		
BTC-1018-SAB1	532	54			25,200		
BTC-1018-PAC1	660	67			27,700		
BTC-1018-CAC1	660	67			27,900		
BTC-1018-SAC1	660	67			27,900		
BTC-1018-CAD1	788	80			30,300		
BTC-1018-SAD1	788	80			30,300		
BTC-1018-PAJ1	876	89			31,700		
BTC-1018-CAJ1	876	89			31,900		
BTC-1018-SAJ1	876	89			31,900		
BTC-1018-DAJ1	876	89			32,300		
BTC-1018-CAE1	916	93			32,900		
BTC-1018-SAE1	916	93			32,900		
BTC-1018-PAK1	1,019	103			34,600		
BTC-1018-CAK1	1,019	103			34,700		
BTC-1018-SAK1	1,019	103			34,800		
BTC-1018-DAK1	1,019	103	35,100				

NOTE

- The last digit of the model number shown represents the number of cells.
- R717 tons are at 96.3°F condensing temperature, a 20°F suction temperature and a 78°F entering wet-bulb temperature.
- For R134a charge, multiply by 1.98. For R22 charge multiply by 1.93. For R404A or R507A charge multiply by 1.65.
- Use this bulletin for preliminary layouts only.** Obtain current drawings from your sales representative.

10' x 24' Two Cell

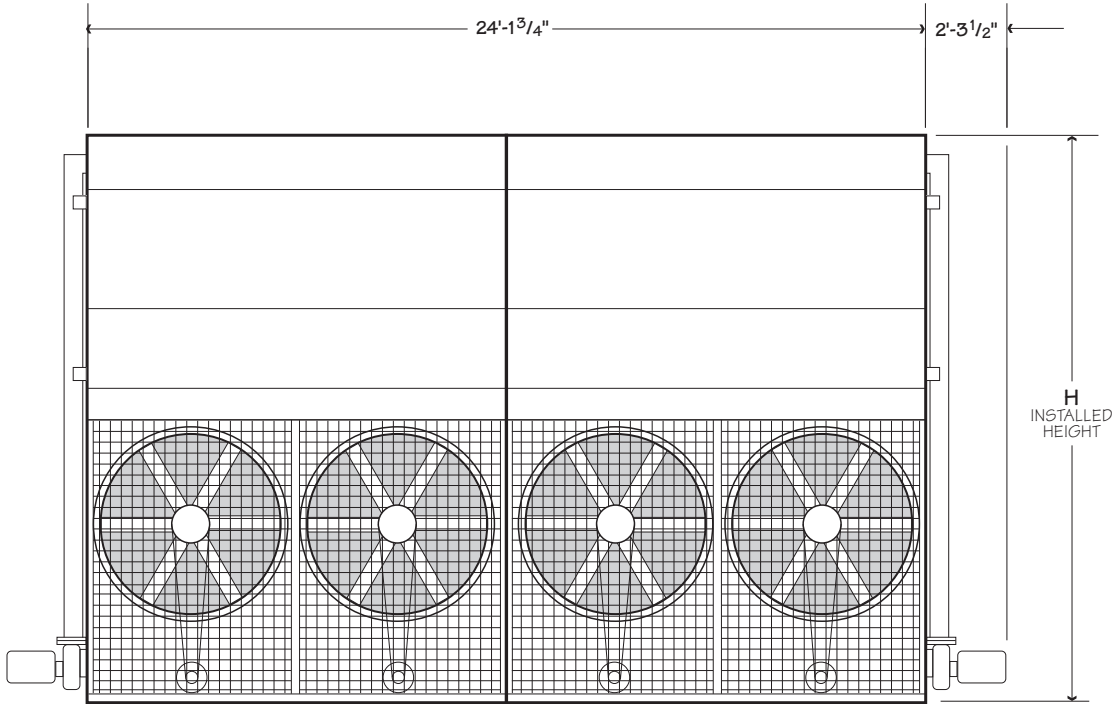

AIR INLET ELEVATION

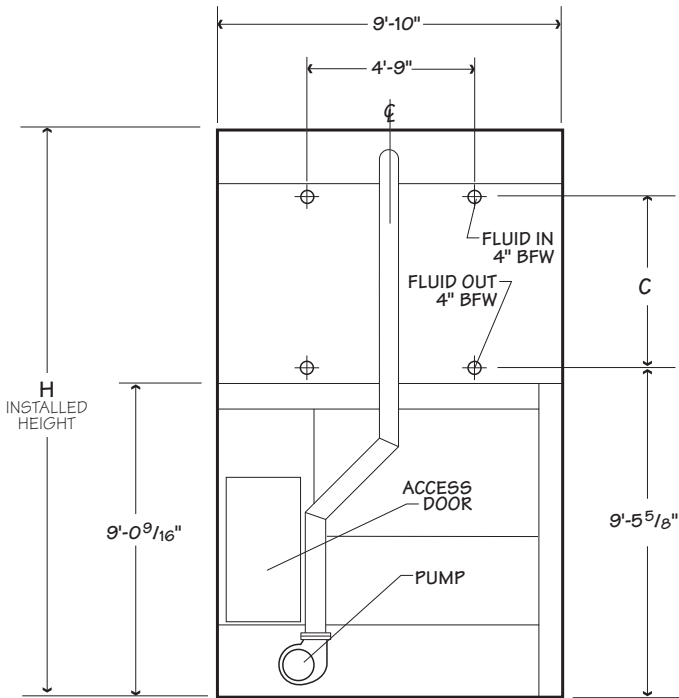

SIDE ELEVATION

Use this data for preliminary layouts only. Obtain current drawing from your sales representative.

*UPDATE*<sup>™</sup> web-based selection software, available at [spxcooling.com/update](http://spxcooling.com/update) provides Cube model recommendations based on customer's specific design requirements.

10' x 24 Two Cell

Model note 1	Base Heat Rejection MBH	R717 Capacity tons - note 2	Fan Motor hp	Airflow Rate cfm	Shipping Weight lb		Design Operating Weight lb	Dimensions	
					Weight/Cell	Heaviest Section		H	C
BTC-1012-AAB2	7,751.2	374	4 x 3	92,522	13,800	8,600	36,400	14'-0 <sup>1</sup> / <sub>16</sub> "	2'-8 <sup>1</sup> / <sub>8</sub> "
BTC-1012-NAB2	8,828.6	426	4 x 5	103,644	13,800	8,600	36,400		
BTC-1012-PAB2	9,740.5	470	4 x 7.5	118,520	13,900	8,600	36,600		
BTC-1012-QAB2	10,403.7	502	4 x 10	128,863	13,900	8,600	36,600		
BTC-1012-NAC2	9,989.5	482	4 x 5	102,216	15,400	10,200	39,800	14'-9 <sup>1</sup> / <sub>16</sub> "	3'-5 <sup>1</sup> / <sub>8</sub> "
BTC-1012-PAC2	11,025.7	532	4 x 7.5	117,516	15,500	10,200	40,000		
BTC-1012-QAC2	11,813.3	570	4 x 10	131,340	15,500	10,200	40,000		
BTC-1012-PAD2	11,191.6	540	4 x 5	119,147	17,100	11,800	43,400	15'-6 <sup>1</sup> / <sub>16</sub> "	4'-2 <sup>1</sup> / <sub>8</sub> "
BTC-1012-QAD2	11,979.1	578	4 x 10	130,644	17,100	11,800	43,400		
BTC-1012-NAJ2	11,134.0	537	4 x 5	102,996	18,000	12,800	45,200		
BTC-1012-PAJ2	11,813.3	570	4 x 7.5	117,414	18,100	12,800	45,400		
BTC-1012-QAJ2	12,642.3	610	4 x 10	129,828	18,100	12,800	45,600		
BTC-1012-SAJ2	13,927.2	672	4 x 15	143,800	18,400	12,800	46,000		
BTC-1012-PAE2	12,062.0	582	4 x 7.5	118,215	18,800	13,500	46,800	16'-3 <sup>1</sup> / <sub>16</sub> "	4'-11 <sup>1</sup> / <sub>8</sub> "
BTC-1012-QAE2	12,932.4	624	4 x 10	129,945	18,800	13,500	46,800		
BTC-1012-NAK2	11,564.6	558	4 x 5	101,096	19,800	14,700	49,200		
BTC-1012-PAK2	12,725.2	614	4 x 5	115,872	20,000	14,700	49,400		
BTC-1012-QAK2	13,637.1	658	4 x 10	128,652	20,000	14,700	49,400		
BTC-1012-SAK2	15,087.8	728	4 x 15	142,908	20,200	14,700	49,800		

Model	R717 Charge lb - note 3	Internal Coil Volume ft <sup>3</sup>	Pump Motor hp	Recirculating Flow Rate gpm	Remote Sump Application		
					Approximate Operating Weight lb	Bottom Outlet Diameter	Volume gal
BTC-1012-AAB2	719	73	2 x 5	1,040	35,600	2 x 8"	940
BTC-1012-NAB2	719	73			35,600		
BTC-1012-PAB2	719	73			36,000		
BTC-1012-QAB2	719	73			36,000		
BTC-1012-NAC2	889	90			39,000		
BTC-1012-PAC2	889	90			39,200		
BTC-1012-QAC2	889	90			39,200		
BTC-1012-PAD2	1,059	107			42,600		
BTC-1012-QAD2	1,059	107			42,600		
BTC-1012-NAJ2	1,176	119			44,600		
BTC-1012-PAJ2	1,176	119			44,800		
BTC-1012-QAJ2	1,176	119			44,800		
BTC-1012-SAJ2	1,176	119			45,200		
BTC-1012-PAE2	1,228	124			46,200		
BTC-1012-QAE2	1,228	124			46,200		
BTC-1012-NAK2	1,365	138			48,400		
BTC-1012-PAK2	1,365	138			48,600		
BTC-1012-QAK2	1,365	138			48,600		
BTC-1012-SAK2	1,365	138	49,200				

NOTE

- The last digit of the model number shown represents the number of cells.
- R717 tons are at 96.3°F condensing temperature, a 20°F suction temperature and a 78°F entering wet-bulb temperature.
- For R134a charge, multiply by 1.98. For R22 charge multiply by 1.93. For R404A or R507A charge multiply by 1.65.
- Use this bulletin for preliminary layouts only.** Obtain current drawings from your sales representative.

10' x 36' Two Cell

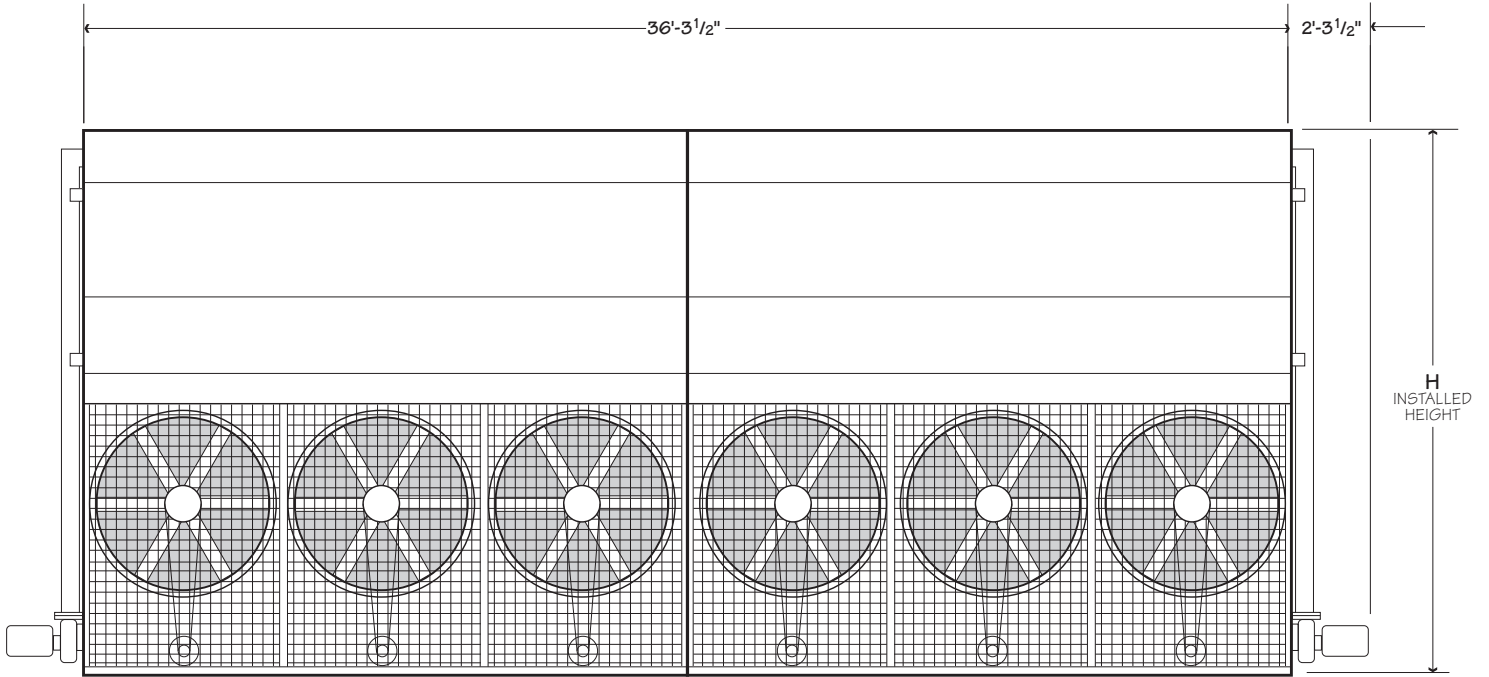

AIR INLET ELEVATION

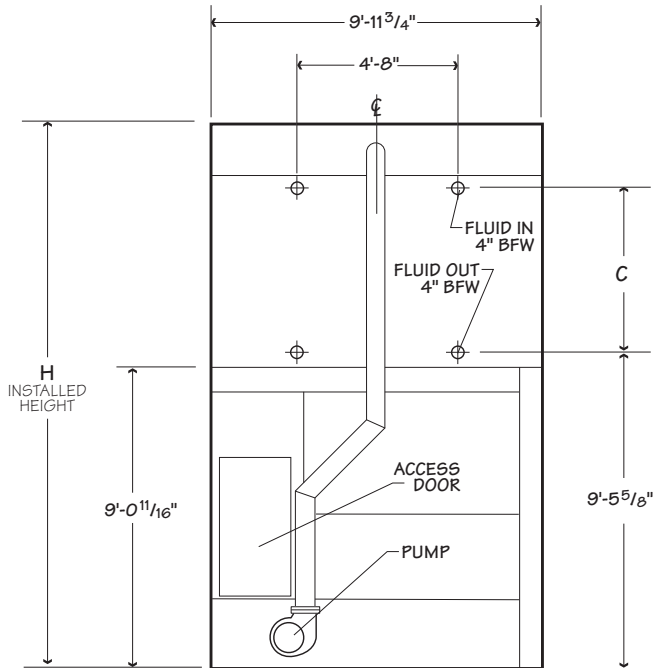

SIDE ELEVATION

Use this data for preliminary layouts only. Obtain current drawing from your sales representative.

*UPDATE™* web-based selection software, available at [spxcooling.com/update](http://spxcooling.com/update) provides Cube model recommendations based on customer's specific design requirements.



10' x 36' Two Cell

Model note 1	Base Heat Rejection MBH	R717 Capacity tons - note 2	Fan Motor hp	Airflow Rate cfm	Shipping Weight lb		Design Operating Weight lb	Dimensions	
					Weight/Cell	Heaviest Section		H	C
BTC-1018-BAB2	11,895.9	574	6 x 3	141,333	19,300	12,100	51,600	14'-0 <sup>1</sup> / <sub>16</sub> "	2'-8 <sup>1</sup> / <sub>8</sub> "
BTC-1018-PAB2	13,553.8	654	6 x 5	158,724	19,300	12,100	51,800		
BTC-1018-CAB2	14,921.6	720	6 x 7.5	185,072	19,500	12,100	52,000		
BTC-1018-SAB2	15,999.3	772	6 x 10	201,982	19,500	12,100	52,200		
BTC-1018-PAC2	15,004.9	724	6 x 5	163,189	21,800	14,600	57,000	14'-9 <sup>1</sup> / <sub>16</sub> "	3'-5 <sup>1</sup> / <sub>8</sub> "
BTC-1018-CAC2	16,497.1	796	6 x 7.5	183,674	22,000	14,600	57,400		
BTC-1018-SAC2	17,657.7	852	6 x 10	200,904	22,000	14,600	57,400		
BTC-1018-CAD2	17,201.8	830	6 x 7.5	182,249	24,300	16,900	62,200	15'-6 <sup>1</sup> / <sub>16</sub> "	4'-2 <sup>1</sup> / <sub>8</sub> "
BTC-1018-SAD2	18,238.0	880	6 x 10	199,832	24,300	16,900	62,400		
BTC-1018-PAJ2	16,870.2	814	6 x 5	157,457	25,600	18,400	65,200		
BTC-1018-CAJ2	17,906.4	864	6 x 7.5	179,550	25,800	18,400	65,400		
BTC-1018-SAJ2	19,232.8	928	6 x 10	198,512	25,800	18,400	65,600		
BTC-1018-DAJ2	21,388.2	1032	6 x 15	220,100	26,200	18,400	66,200		
BTC-1018-CAE2	18,486.7	892	6 x 7.5	180,807	26,800	19,400	67,400	16'-3 <sup>1</sup> / <sub>16</sub> "	4'-11 <sup>1</sup> / <sub>8</sub> "
BTC-1018-SAE2	19,730.2	952	6 x 10	198,756	26,800	19,400	67,400		
BTC-1018-PAK2	17,160.4	828	6 x 5	150,000	28,300	21,100	70,800		
BTC-1018-CAK2	19,150.0	924	6 x 7.5	177,216	28,500	21,100	71,200		
BTC-1018-SAK2	20,807.9	1004	6 x 10	196,724	28,500	21,100	71,200		
BTC-1018-DAK2	22,921.9	1106	6 x 15	218,742	28,900	21,100	71,800		

Model	R717 Charge lb - note 3	Internal Coil Volume ft <sup>3</sup>	Pump Motor hp	Recirculating Flow Rate gpm	Remote Sump Application		
					Approximate Operating Weight lb	Bottom Outlet Diameter	Volume gal
BTC-1018-BAB2	1,064	108	2 x 7.5	1,580	50,000	2 x 10"	1,320
BTC-1018-PAB2	1,064	108			50,000		
BTC-1018-CAB2	1,064	108			50,400		
BTC-1018-SAB2	1,064	108			50,400		
BTC-1018-PAC2	1,320	134			55,400		
BTC-1018-CAC2	1,320	134			55,800		
BTC-1018-SAC2	1,320	134			55,800		
BTC-1018-CAD2	1,575	159			60,600		
BTC-1018-SAD2	1,575	159			60,600		
BTC-1018-PAJ2	1,753	177			63,400		
BTC-1018-CAJ2	1,753	177			63,800		
BTC-1018-SAJ2	1,753	177			63,800		
BTC-1018-DAJ2	1,753	177			64,600		
BTC-1018-CAE2	1,831	185			65,800		
BTC-1018-SAE2	1,831	185			65,800		
BTC-1018-PAK2	2,038	206			69,200		
BTC-1018-CAK2	2,038	206			69,400		
BTC-1018-SAK2	2,038	206			69,600		
BTC-1018-DAK2	2,038	206	70,200				

NOTE

- The last digit of the model number shown represents the number of cells.
- R717 tons are at 96.3°F condensing temperature, a 20°F suction temperature and a 78°F entering wet-bulb temperature.
- For R134a charge, multiply by 1.98. For R22 charge multiply by 1.93. For R404A or R507A charge multiply by 1.65.
- Use this bulletin for preliminary layouts only.** Obtain current drawings from your sales representative.

12' x 12' Single Cell

Use this data for preliminary layouts only. Obtain current drawing from your sales representative.

*UPDATE™* web-based selection software, available at [spxcooling.com/update](http://spxcooling.com/update) provides Cube model recommendations based on customer's specific design requirements.

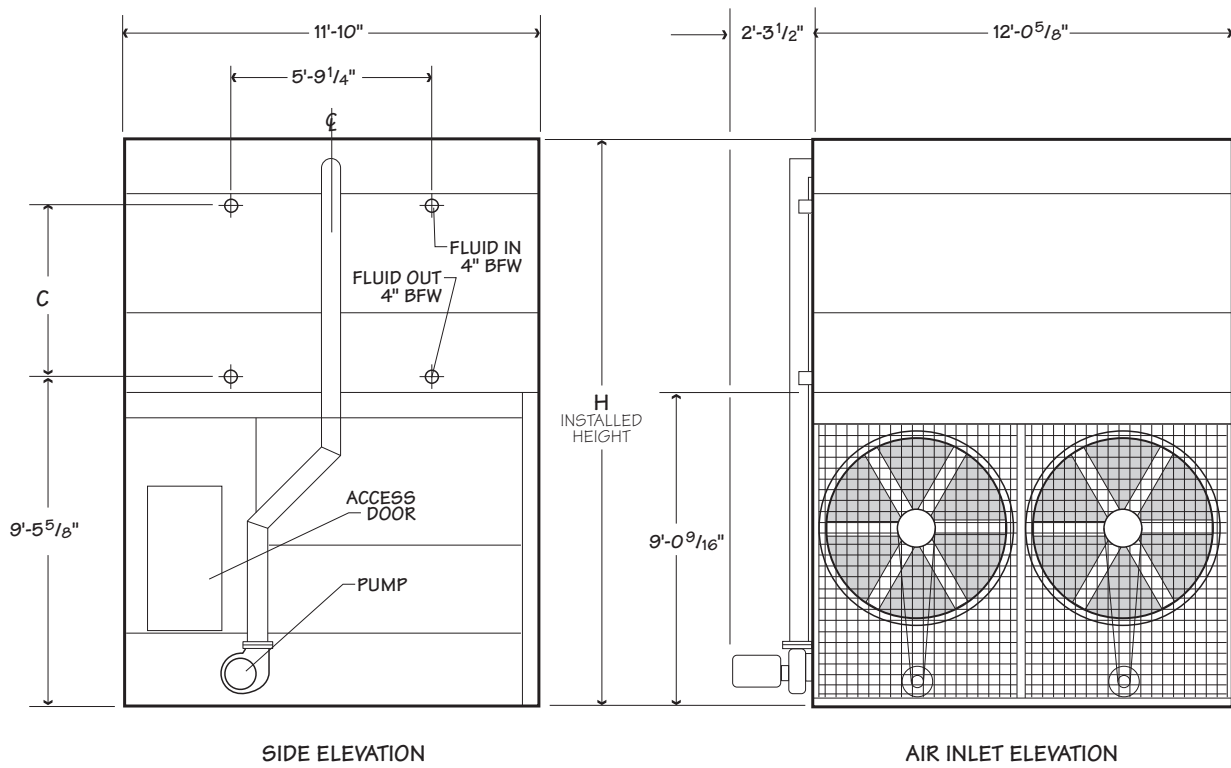

12' x 12' Single Cell

Model note 1	Base Heat Rejection MBH	R717 Capacity tons - note 2	Fan Motor hp	Airflow Rate cfm	Shipping Weight lb		Design Operating Weight lb	Dimensions	
					Weight/Cell	Heaviest Section		H	C
BTC-1212-AAB1	4,439.0	214	2 x 3	50,617	15,600	10,100	20,700	14'-0 <sup>1</sup> / <sub>16</sub> "	2'-8 <sup>1</sup> / <sub>8</sub> "
BTC-1212-NAB1	5,027.4	243	2 x 5	57,802	15,600	10,100	20,700		
BTC-1212-PAB1	5,541.9	267	2 x 7.5	66,482	15,700	10,100	20,900		
BTC-1212-QAB1	5,939.0	287	2 x 10	72,682	15,700	10,100	20,900		
BTC-1212-NAC1	5,601.0	270	2 x 5	59,004	17,500	12,000	22,700	14'-9 <sup>1</sup> / <sub>16</sub> "	3'-5 <sup>1</sup> / <sub>8</sub> "
BTC-1212-PAC1	6,174.0	298	2 x 7.5	67,020	17,600	12,000	22,800		
BTC-1212-OAC1	6,629.7	320	2 x 10	73,666	17,600	12,000	22,900		
BTC-1212-PAD1	6,445.5	311	2 x 7.5	66,415	19,500	13,900	24,800	15'-6 <sup>1</sup> / <sub>16</sub> "	4'-2 <sup>1</sup> / <sub>8</sub> "
BTC-1212-OAD1	6,923.7	334	2 x 10	73,203	19,500	13,900	24,900		
BTC-1212-SAD1	7,541.1	364	2 x 15	81,436	19,800	13,900	25,100		
BTC-1212-QAJ1	7,217.7	348	2 x 10	72,318	20,700	15,100	26,100		
BTC-1212-SAJ1	7,953.0	384	2 x 15	81,093	21,000	15,100	26,400		
BTC-1212-TAJ1	8,526.0	411	2 x 20	88,182	21,000	15,100	26,400		
BTC-1212-PAE1	6,963.6	336	2 x 7.5	65,802	21,500	15,900	26,900		
BTC-1212-OAE1	7,481.7	361	2 x 10	72,733	21,500	15,900	26,900	16'-3 <sup>1</sup> / <sub>16</sub> "	4'-11 <sup>1</sup> / <sub>8</sub> "
BTC-1212-SAE1	8,144.9	393	2 x 15	81,080	21,700	15,900	27,200		
BTC-1212-OAK1	7,894.0	381	2 x 10	71,558	22,900	17,300	28,400		
BTC-1212-SAK1	8,599.5	415	2 x 15	80,500	23,200	17,300	28,700		
BTC-1212-TAK1	9,202.2	444	2 x 20	87,719	23,200	17,300	28,700		

Model	R717 Charge lb - note 3	Internal Coil Volume ft <sup>3</sup>	Pump Motor hp	Recirculating Flow Rate gpm	Remote Sump Application		
					Approximate Operating Weight lb	Bottom Outlet Diameter	Volume gal
BTC-1212-AAB1	435	44	5	620	20,200	10"	540
BTC-1212-NAB1	435	44			20,200		
BTC-1212-PAB1	435	44			20,400		
BTC-1212-QAB1	435	44			20,400		
BTC-1212-NAC1	537	54			22,200		
BTC-1212-PAC1	537	54			22,400		
BTC-1212-OAC1	537	54			22,400		
BTC-1212-PAD1	640	65			24,300		
BTC-1212-OAD1	640	65			24,400		
BTC-1212-SAD1	640	65			24,600		
BTC-1212-QAJ1	710	72			25,700		
BTC-1212-SAJ1	710	72			25,900		
BTC-1212-TAJ1	710	72			26,000		
BTC-1212-PAE1	743	75			26,400		
BTC-1212-OAE1	743	75			26,400		
BTC-1212-SAE1	743	75			26,700		
BTC-1212-OAK1	825	83			27,900		
BTC-1212-SAK1	825	83			28,200		
BTC-1212-TAK1	825	83			28,200		

NOTE

- The last digit of the model number shown represents the number of cells.
- R717 tons are at 96.3°F condensing temperature, a 20°F suction temperature and a 78°F entering wet-bulb temperature.
- For R134a charge, multiply by 1.98. For R22 charge multiply by 1.93. For R404A or R507A charge multiply by 1.65.
- Use this bulletin for preliminary layouts only.** Obtain current drawings from your sales representative.

12' x 18' Single Cell

Use this data for preliminary layouts only. Obtain current drawing from your sales representative.

*UPDATE™* web-based selection software, available at [spxcooling.com/update](http://spxcooling.com/update) provides Cube model recommendations based on customer's specific design requirements.

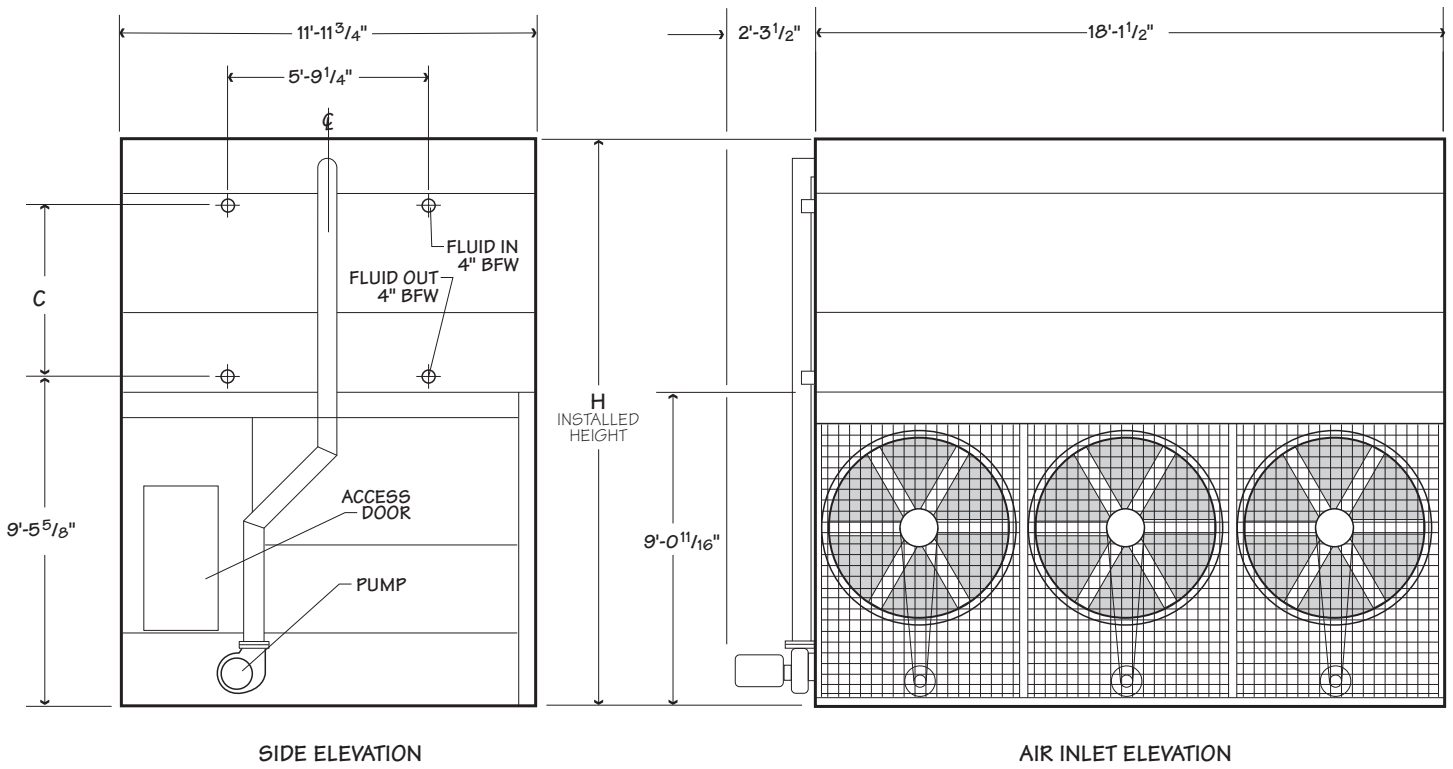

12' x18' Single Cell

Model note 1	Base Heat Rejection MBH	R717 Capacity tons - note 2	Fan Motor hp	Airflow Rate cfm	Shipping Weight lb		Design Operating Weight lb	Dimensions	
					Weight/Cell	Heaviest Section		H	C
BTC-1218-BAB1	7,233.0	349	3 x 3	76,962	21,800	14,200	29,400	14'-0 <sup>1</sup> / <sub>16</sub> "	2'-8 <sup>1</sup> / <sub>8</sub> "
BTC-1218-PAB1	7,732.2	373	3 x 5	88,028	21,800	14,200	29,500		
BTC-1218-CAB1	8,540.7	412	3 x 7.5	101,244	22,000	14,200	29,600		
BTC-1218-SAB1	9,158.4	442	3 x 10	110,715	22,000	14,200	29,600		
BTC-1218-PAC1	8,555.0	413	3 x 5	86,709	24,800	17,100	32,600	14'-9 <sup>1</sup> / <sub>16</sub> "	3'-5 <sup>1</sup> / <sub>8</sub> "
BTC-1218-CAC1	9,437.4	455	3 x 7.5	100,251	24,900	17,100	32,800		
BTC-1218-SAC1	10,113.8	488	3 x 10	109,920	25,000	17,100	32,800	15'-6 <sup>1</sup> / <sub>16</sub> "	4'-2 <sup>1</sup> / <sub>8</sub> "
BTC-1218-CAD1	9,761.0	471	3 x 7.5	99,237	27,700	19,900	35,700		
BTC-1218-SAD1	10,452.0	504	3 x 10	111,395	27,700	19,900	35,700		
BTC-1218-DAD1	11,540.0	557	3 x 15	124,077	28,100	19,900	36,000		
BTC-1218-SAJ1	11,025.0	532	3 x 10	110,003	29,500	21,700	37,600		
BTC-1218-DAJ1	12,157.0	587	3 x 15	123,485	29,900	21,700	38,000		
BTC-1218-VAJ1	13,039.0	629	3 x 20	134,346	30,000	21,700	38,100	16'-3 <sup>1</sup> / <sub>16</sub> "	4'-11 <sup>1</sup> / <sub>8</sub> "
BTC-1218-CAE1	10,528.3	508	3 x 7.5	100,107	30,600	22,800	38,700		
BTC-1218-SAE1	11,295.1	545	3 x 10	110,667	30,600	22,800	38,700		
BTC-1218-DAE1	12,455.7	601	3 x 15	123,526	31,000	22,800	39,100		
BTC-1218-SAK1	11,937.6	576	3 x 10	108,837	32,700	24,900	41,000		
BTC-1218-DAK1	13,156.5	635	3 x 15	122,571	33,100	24,900	41,300		
BTC-1218-VAK1	14,067.9	679	3 x 20	133,647	33,200	24,900	41,400		

Model	R717 Charge lb - note 3	Internal Coil Volume ft <sup>3</sup>	Pump Motor hp	Recirculating Flow Rate gpm	Remote Sump Application		
					Approximate Operating Weight lb	Bottom Outlet Diameter	Volume gal
BTC-1218-BAB1	643	65	75	900	28,300	10"	760
BTC-1218-PAB1	643	65			28,300		
BTC-1218-CAB1	643	65			28,500		
BTC-1218-SAB1	643	65			28,500		
BTC-1218-PAC1	798	81			31,500		
BTC-1218-CAC1	798	81			31,600		
BTC-1218-SAC1	798	81			31,700		
BTC-1218-CAD1	952	96			34,600		
BTC-1218-SAD1	952	96			34,600		
BTC-1218-DAD1	952	96			34,900		
BTC-1218-SAJ1	1,059	107			36,500		
BTC-1218-DAJ1	1,059	107			36,900		
BTC-1218-VAJ1	1,059	107			37,000		
BTC-1218-CAE1	1,107	112			37,600		
BTC-1218-SAE1	1,107	112			37,600		
BTC-1218-DAE1	1,107	112			38,000		
BTC-1218-SAK1	1,231	125			39,900		
BTC-1218-DAK1	1,231	125			40,200		
BTC-1218-VAK1	1,231	125	40,300				

NOTE

- The last digit of the model number shown represents the number of cells.
- R717 tons are at 96.3°F condensing temperature, a 20°F suction temperature and a 78°F entering wet-bulb temperature.
- For R134a charge, multiply by 1.98. For R22 charge multiply by 1.93. For R404A or R507A charge multiply by 1.65.
- Use this bulletin for preliminary layouts only.** Obtain current drawings from your sales representative.

12' x 24' Two Cell

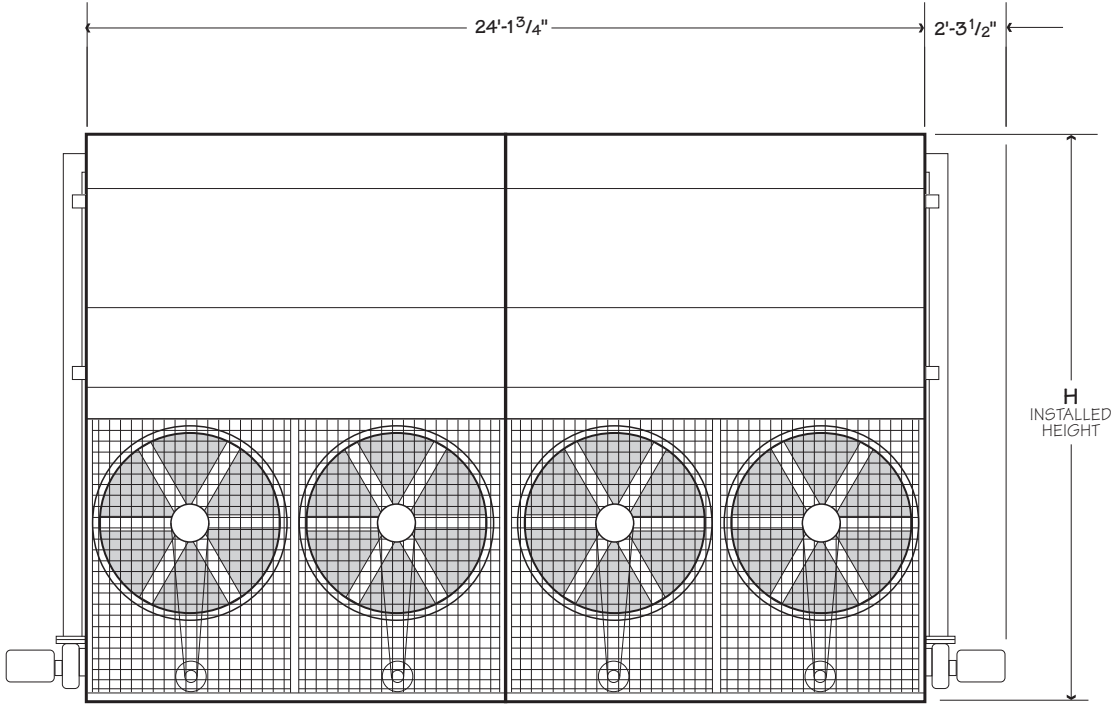

AIR INLET ELEVATION

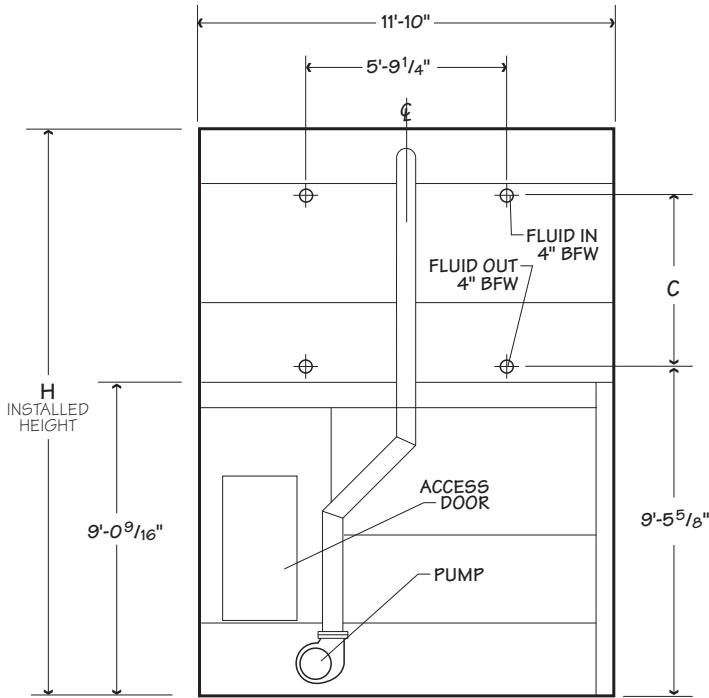

SIDE ELEVATION

Use this data for preliminary layouts only. Obtain current drawing from your sales representative.

*UPDATE™* web-based selection software, available at [spxcooling.com/update](http://spxcooling.com/update) provides Cube model recommendations based on customer's specific design requirements.



12' x 24' Two Cell

Model note 1	Base Heat Rejection MBH	R717 Capacity tons - note 2	Fan Motor hp	Airflow Rate cfm	Shipping Weight lb		Design Operating Weight lb	Dimensions	
					Weight/Cell	Heaviest Section		H	C
BTC-1212-AAB2	8,878.0	428	4 x 3	101,234	15,600	10,100	41,400	14'-0 <sup>1</sup> / <sub>16</sub> "	2'-8 <sup>1</sup> / <sub>8</sub> "
BTC-1212-NAB2	10,054.8	485	4 x 5	115,604	15,600	10,100	41,400		
BTC-1212-PAB2	11,083.8	535	4 x 7.5	132,964	15,700	10,100	41,800		
BTC-1212-QAB2	11,878.0	573	4 x 10	145,364	15,700	10,100	41,800		
BTC-1212-NAC2	11,202.0	541	4 x 5	118,008	17,500	12,000	45,400	14'-9 <sup>1</sup> / <sub>16</sub> "	3'-5 <sup>1</sup> / <sub>8</sub> "
BTC-1212-PAC2	12,348.0	596	4 x 7.5	134,040	17,600	12,000	45,600		
BTC-1212-QAC2	13,259.4	640	4 x 10	147,332	17,600	12,000	45,800		
BTC-1212-PAD2	12,891.0	622	4 x 7.5	132,830	19,500	13,900	49,600	15'-6 <sup>1</sup> / <sub>16</sub> "	4'-2 <sup>1</sup> / <sub>8</sub> "
BTC-1212-QAD2	13,847.4	668	4 x 10	146,406	19,500	13,900	49,800		
BTC-1212-SAD2	15,082.2	728	4 x 15	162,872	19,800	13,900	50,200		
BTC-1212-QAJ2	14,435.4	697	4 x 10	144,636	20,700	15,100	52,200		
BTC-1212-SAJ2	15,906.0	767	4 x 15	162,186	21,000	15,100	52,800		
BTC-1212-TAJ2	17,052.0	823	4 x 20	176,364	21,000	15,100	52,800		
BTC-1212-PAE2	13,927.2	672	4 x 7.5	131,603	21,500	15,900	53,800	16'-3 <sup>1</sup> / <sub>16</sub> "	4'-11 <sup>1</sup> / <sub>8</sub> "
BTC-1212-QAE2	14,963.4	722	4 x 10	145,466	21,500	15,900	53,800		
BTC-1212-SAE2	16,289.8	786	4 x 15	162,160	21,700	15,900	54,400		
BTC-1212-QAK2	15,788.0	762	4 x 10	143,116	22,900	17,300	56,800		
BTC-1212-SAK2	17,199.0	830	4 x 15	161,000	23,200	17,300	57,400		
BTC-1212-TAK2	18,404.4	888	4 x 20	175,438	23,200	17,300	57,400		

Model	R717 Charge lb - note 3	Internal Coil Volume ft <sup>3</sup>	Pump Motor hp	Recirculating Flow Rate gpm	Remote Sump Application		
					Approximate Operating Weight lb	Bottom Outlet Diameter	Volume gal
BTC-1212-AAB2	870	88	2 x 5	1,240	40,400	2 x 10"	1,080
BTC-1212-NAB2	870	88			40,400		
BTC-1212-PAB2	870	88			40,800		
BTC-1212-QAB2	870	88			40,800		
BTC-1212-NAC2	1,075	109			44,400		
BTC-1212-PAC2	1,075	109			44,800		
BTC-1212-QAC2	1,075	109			44,800		
BTC-1212-PAD2	1,280	130			48,600		
BTC-1212-QAD2	1,280	130			48,800		
BTC-1212-SAD2	1,280	130			49,200		
BTC-1212-QAJ2	1,421	144			51,400		
BTC-1212-SAJ2	1,421	144			51,800		
BTC-1212-TAJ2	1,421	144			52,000		
BTC-1212-PAE2	1,485	150			52,800		
BTC-1212-QAE2	1,485	150			52,800		
BTC-1212-SAE2	1,485	150			53,400		
BTC-1212-QAK2	1,649	167			55,800		
BTC-1212-SAK2	1,649	167			56,400		
BTC-1212-TAK2	1,649	167			56,400		

NOTE

- The last digit of the model number shown represents the number of cells.
- R717 tons are at 96.3°F condensing temperature, a 20°F suction temperature and a 78°F entering wet-bulb temperature.
- For R134a charge, multiply by 1.98. For R22 charge multiply by 1.93. For R404A or R507A charge multiply by 1.65.
- Use this bulletin for preliminary layouts only.** Obtain current drawings from your sales representative.

12' x 36' Two Cell

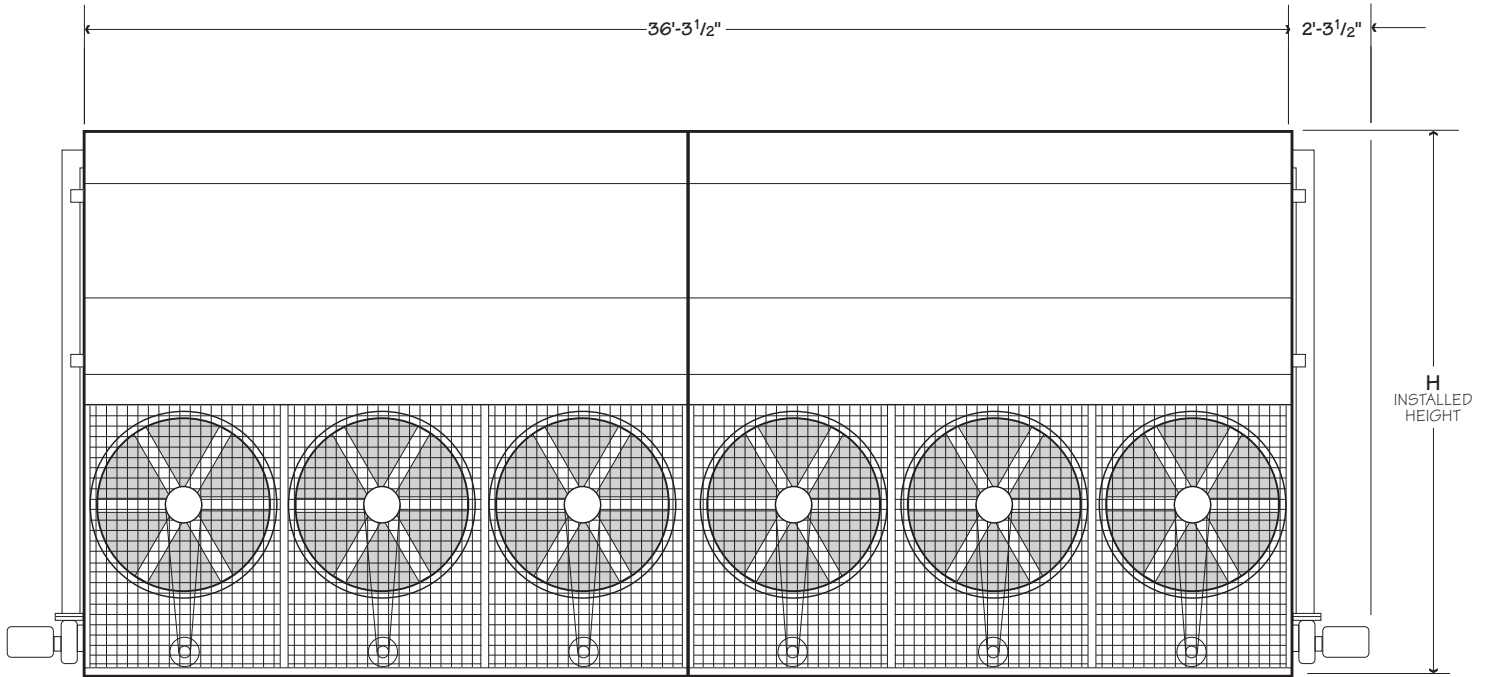

AIR INLET ELEVATION

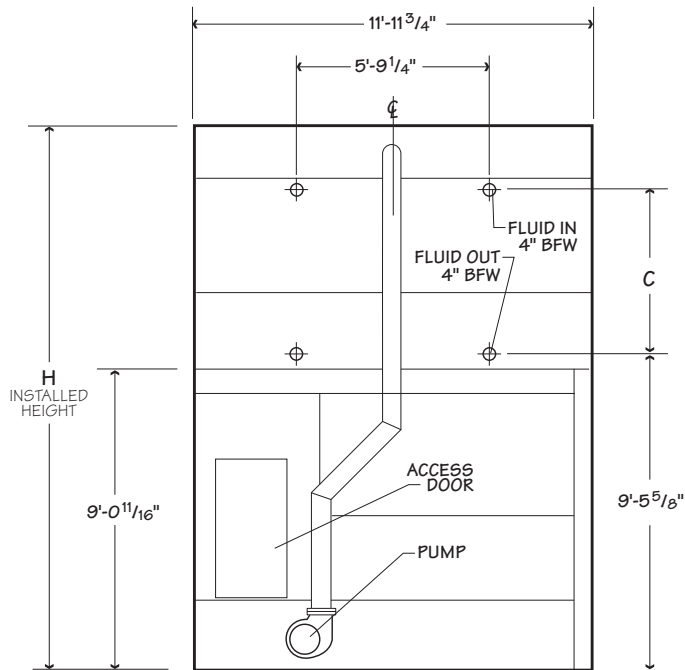

SIDE ELEVATION

Use this data for preliminary layouts only. Obtain current drawing from your sales representative.

*UPDATE™* web-based selection software, available at [spxcolling.com/update](http://spxcolling.com/update) provides Cube model recommendations based on customer's specific design requirements.

12' x 36' Two Cell

Model note 1	Base Heat Rejection MBH	R717 Capacity tons - note 2	Fan Motor hp	Airflow Rate cfm	Shipping Weight lb		Design Operating Weight lb	Dimensions	
					Weight/Cell	Heaviest Section		H	C
BTC-1218-BAB2	14,466.0	698	6 x 3	153,924	21,800	14,200	58,800	14'-0 <sup>1</sup> / <sub>16</sub> "	2'-8 <sup>1</sup> / <sub>8</sub> "
BTC-1218-PAB2	15,464.4	746	6 x 5	176,056	21,800	14,200	59,000		
BTC-1218-CAB2	17,081.4	824	6 x 7.5	202,488	22,000	14,200	59,200		
BTC-1218-SAB2	18,316.8	884	6 x 10	221,430	22,000	14,200	59,200		
BTC-1218-PAC2	17,110.0	826	6 x 5	173,418	24,800	17,100	65,200	14'-9 <sup>1</sup> / <sub>16</sub> "	3'-5 <sup>1</sup> / <sub>8</sub> "
BTC-1218-CAC2	18,874.8	911	6 x 7.5	200,502	24,900	17,100	65,600		
BTC-1218-SAC2	20,227.6	976	6 x 10	219,840	25,000	17,100	65,600		
BTC-1218-CAD2	19,522.0	942	6 x 7.5	198,474	27,700	19,900	71,400	15'-6 <sup>1</sup> / <sub>16</sub> "	4'-2 <sup>1</sup> / <sub>8</sub> "
BTC-1218-SAD2	20,904.0	1,009	6 x 10	222,790	27,700	19,900	71,400		
BTC-1218-DAD2	23,080.0	1,114	6 x 15	248,154	28,100	19,900	72,000		
BTC-1218-SAJ2	22,050.0	1,064	6 x 10	220,006	29,500	21,700	75,200		
BTC-1218-DAJ2	24,314.0	1,173	6 x 15	246,970	29,900	21,700	76,000		
BTC-1218-VAJ2	26,078.0	1,258	6 x 20	268,692	30,000	21,700	76,200		
BTC-1218-CAE2	21,056.6	1,016	6 x 7.5	200,214	30,600	22,800	77,400	16'-3 <sup>1</sup> / <sub>16</sub> "	4'-11 <sup>1</sup> / <sub>8</sub> "
BTC-1218-SAE2	22,590.3	1,090	6 x 10	221,334	30,600	22,800	77,400		
BTC-1218-DAE2	24,911.5	1,202	6 x 15	247,052	31,000	22,800	78,200		
BTC-1218-SAK2	23,875.2	1,152	6 x 10	217,674	32,700	24,900	82,000		
BTC-1218-DAK2	26,313.0	1,270	6 x 15	245,142	33,100	24,900	82,600		
BTC-1218-VAK2	28,135.8	1,358	6 x 20	267,294	33,200	24,900	82,800		

Model	R717 Charge lb - note 3	Internal Coil Volume ft <sup>3</sup>	Pump Motor hp	Recirculating Flow Rate gpm	Remote Sump Application		
					Approximate Operating Weight lb	Bottom Outlet Diameter	Volume gal
BTC-1218-BAB2	1,286	130	2 x 7.5	1,800	56,600	2 x 10"	1,520
BTC-1218-PAB2	1,286	130			56,600		
BTC-1218-CAB2	1,286	130			57,000		
BTC-1218-SAB2	1,286	130			57,000		
BTC-1218-PAC2	1,596	162			63,000		
BTC-1218-CAC2	1,596	162			63,200		
BTC-1218-SAC2	1,596	162			63,400		
BTC-1218-CAD2	1,905	193			69,200		
BTC-1218-SAD2	1,905	193			69,200		
BTC-1218-DAD2	1,905	193			69,800		
BTC-1218-SAJ2	2,118	214			73,000		
BTC-1218-DAJ2	2,118	214			73,800		
BTC-1218-VAJ2	2,118	214			74,000		
BTC-1218-CAE2	2,214	224			75,200		
BTC-1218-SAE2	2,214	224			75,200		
BTC-1218-DAE2	2,214	224			76,000		
BTC-1218-SAK2	2,463	249			79,800		
BTC-1218-DAK2	2,463	249			80,400		
BTC-1218-VAK2	2,463	249	80,600				

NOTE

- The last digit of the model number shown represents the number of cells.
- R717 tons are at 96.3°F condensing temperature, a 20°F suction temperature and a 78°F entering wet-bulb temperature.
- For R134a charge, multiply by 1.98. For R22 charge multiply by 1.93. For R404A or R507A charge multiply by 1.65.
- Use this bulletin for preliminary layouts only.** Obtain current drawings from your sales representative.

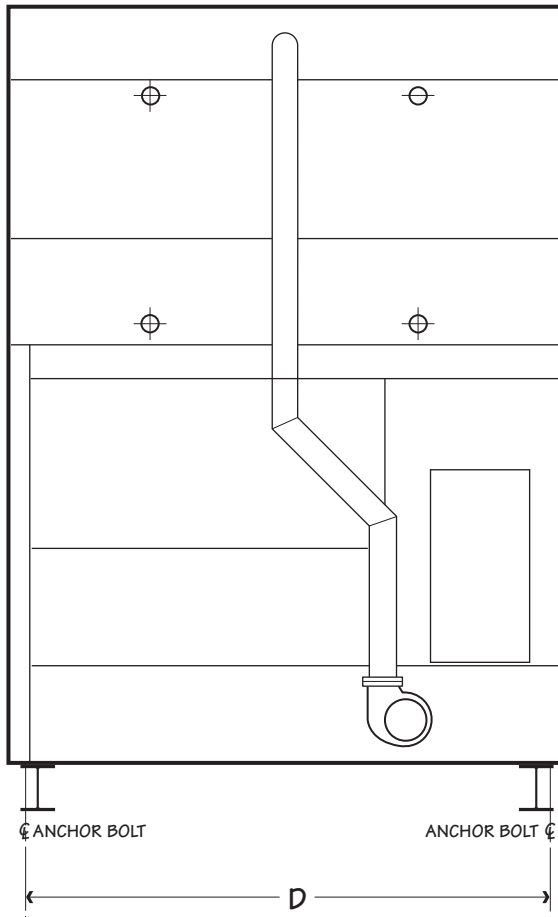

Model	D	Maximum Deflection
BTC-1012	9'-7½"	¾"
BTC-1018	9'-7½"	¾"
BTC-1212	11'-7½"	½"
BTC-1218	11'-7½"	½"

**NOTE**

1. The recommended supporting steel arrangement for the Cube BTC Evap Condenser consists of parallel I-beams running the full length of the unit.
2. Supporting steel is to be designed, constructed and furnished by others.
3. The top surface of the supporting steel must be framed flush and level.
4. If vibration isolators are used, they must be placed underneath the supporting steel beams.
5. Consider provisions for access to the condenser if the supporting steel is elevated above grade.
6. **Use this bulletin for preliminary layouts only.** Obtain current drawings from your sales representative.

The purpose of a basin heater is to prevent recirculating water from freezing in the collection basin during periods of shutdown or standby operation. Heater systems are sized according to tower model and ambient temperature to give maximum protection against freezing in the collection basin. They are not intended to protect the coil and other components from icing.

An automatic basin water heater system consists of the following components:

- Stainless steel electric immersion heater(s). Threaded couplings are provided in the side of the collection basin.
- NEMA 4 enclosure containing:
  - Transformer to convert power supply to 24 volts for control circuit.
  - Magnetic contactor to energize heater.
  - Solid state circuit board for temperature and low-water cutoff.
  - The enclosure may be mounted on the side of the condenser.
- Control probe in the collection basin to monitor water temperature and level.



Heater components are typically shipped separately for installation by others.

Heat trace and insulation of the pump may be optionally selected.

Model	Heater Size kW		
	0°F Ambient	-20°F Ambient	-40°F Ambient
BTC-1012	7.5	12	2 x 7.5
BTC-1018	12	2 x 7.5	2 x 12
BTC-1212	9	2 x 7.5	2 x 9
BTC-1218	2 x 7.5	2 x 9	2 x 12

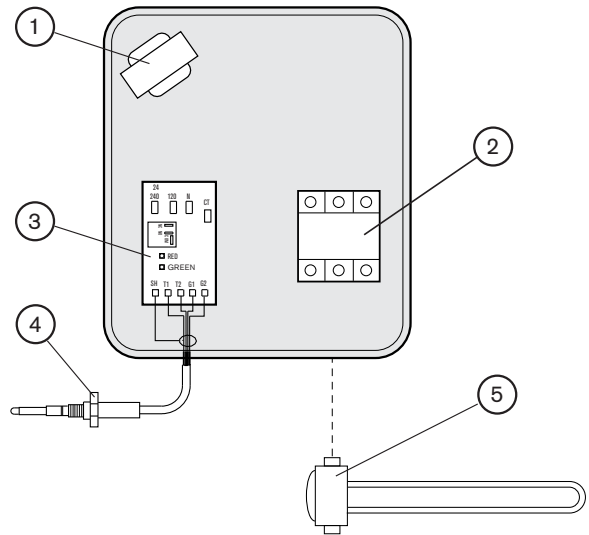

1. Transformer
2. Contactor
3. Solid State Relay Card
4. Sensor Probe
5. Heater Element(s)

### Condenser Recirculating Water

When the ambient air temperature falls below 32°F, the recirculating water within the condenser can freeze. *Marley Technical Report #H-003 “Cooling Towers and Freezing Weather”* describes how to prevent freezing during operation. Ask your sales representative for a copy or download a copy at [spxcooling.com](http://spxcooling.com).

During shutdown, water collects in the basin and may freeze solid. You can prevent freezing by adding heat to the water left in the basin or, you can drain the condenser basin and all exposed pipework at shutdown.

### Remote Sump Application

With this type of system, recirculating water used by the condenser for evaporative heat rejection is pumped to the condenser spray system from a remote tank and flows by gravity from the condenser back to the tank. At shutdown, all exposed water drains into the tank, located in a heated space, where it is safe from freezing. The amount of water needed to successfully operate the system depends on condenser size and volume of water contained in the piping system to and from the condenser. Select a tank large enough to contain those combined volumes, plus a level sufficient to maintain a flooded suction on the pump. Control makeup water according to the level where the tank stabilizes during operation.

### System Cleanliness

The Cube Evaporative Condenser can be a very effective air washer. Atmospheric dust and particulates able to pass through the relatively small louver or screen openings will enter the recirculating water system. Increased concentrations can intensify systems maintenance by clogging screens and strainers—and smaller particulates can coat system heat transfer surfaces. In areas of low flow velocity, such as the collection basin, sedimentary deposits can provide a breeding ground for bacteria.

In areas prone to dust and particulates, consider installing some means for keeping the collection basin clean. Typical devices include basin sweeper piping in conjunction with side stream filters and a variety of filtration media.

### Blowdown

Blowdown or bleed-off is the continuous removal of a small portion of the water from the open recirculating system. Blowdown is used to prevent the dissolved solids from concentrating to the point where they will form scale. The amount of blowdown required depends on the heat load and the composition of the makeup water. The Cube Condenser is equipped with a blowdown line with metering valve connected directly to the overflow. Specific blowdown adjustment instructions and additional blowdown information can be found in the applicable *Cube Condenser User Manual*.

### Water Treatment

To control the buildup of dissolved solids resulting from water evaporation, as well as airborne impurities and biological contaminants including Legionella, an effective, consistent water treatment program is required. Simple blowdown may be adequate to control corrosion and scale, but biological contamination can only be controlled with biocides. An acceptable water treatment program must be compatible with the variety of materials incorporated in the condenser. Ideally the pH of the recirculating water should fall between 6.5 and 9.0. Batch feeding of the chemicals directly into the condenser is not recommended since localized damage is possible. Specific startup instructions and additional water quality recommendations can be found in the *Cube Condenser User Manual* which accompanies the condenser and also is available from your sales representative.

### Air Circulation

Considering the air path entering and exiting the condenser is critical to ensure the condenser operates as designed. Obstructions near the air inlet(s) and discharge should be located a sufficient distance away so as not to impede airflow. If the condenser is to be located in an enclosure or near tall barriers, the air discharge should be positioned at an elevation higher than the top of the barriers to discourage recirculation of the hot discharge air. The condenser must be located at such distance and direction to avoid the possibility of contaminated discharge air being drawn into building fresh air intake ducts.

### Piping

Always follow accepted engineering practices during design and installation of condenser piping. All piping must be supported independent of the condenser—no loads are to be supported by the condenser coil connections or condenser structure. Precautions must be taken to protect the condenser from excess heat generated during welding.



Furnish and install a forced draft, counterflow, evaporative condenser with a condensing capacity of \_\_\_\_\_ MBH heat rejection while operating with \_\_\_\_\_ refrigerant at \_\_\_\_\_°F condensing temperature and \_\_\_\_\_°F entering wet-bulb temperature.

Unit shall consist of \_\_\_\_\_ cell(s), as shown on plans. The limiting overall dimensions of the condenser shall be \_\_\_\_\_ft wide, \_\_\_\_\_ft long, and \_\_\_\_\_ft high. Total operating power of all fans shall not exceed \_\_\_\_\_ hp, consisting of \_\_\_\_\_@ \_\_\_\_\_ hp motor(s). Tower shall be similar and equal in all aspects to Cube BTC Evaporative Condenser Model \_\_\_\_\_.

**Collection Basin and Casing:** The collection basin and casing shall be heavy-gauge G-235 galvanized steel. To reduce potential for leaks, bolts shall be used in all submerged areas; self-tapping screws are not permitted. A factory-installed, float operated, mechanical make-up valve shall be included. An overflow and drain connection shall be provided in each cell. The basin floor shall slope towards the drain to allow complete flushing of debris. The collection basin shall be tested for leaks at the factory.

**Fan Motor:** Fan motor(s) shall be NEMA Premium Efficiency, TEFC, 1.15 service factor, variable torque, inverter ready and insulated for cooling tower duty, with each motor serving a single fan drive assembly. Motors shall be nameplated for 3 phase, 60 Hz, \_\_\_\_\_ volt operation.

**Fan:** Fan(s) shall be dual stage propeller-type, incorporating aluminum alloy blades. Fan(s) shall be driven through an industrial grade system of V-belts, pulleys, and tapered roller bearings designed for 150% of nameplate power. Bearings shall be rated at an  $L_{10}$  life of 100,000 hours or greater, with extended lubrication lines for easy maintenance. Fan sections shall be separated by a partition wall extending to the back of the unit.

**Pump:** Recirculation pump(s) shall be centrifugal with mechanical seal, mounted to the collection basin in conjunction with a suction assembly, and close-coupled with a \_\_\_\_\_hp TEFC pump motor nameplated for 3 phase, 60 Hz, \_\_\_\_\_volt operation. Recirculation piping shall be schedule 40 PVC. A blowdown line with metering valve shall be connected directly to the evaporative condenser overflow.

**Heat Transfer Coil:** Condenser coil(s) shall be constructed of continuous serpentine circuits assembled into fully welded headers and hot dip galvanized after fabrication. Each coil shall be tested at 375 psig air pressure under water. Coil tubes shall be sloped for free drainage of fluid.

**Water Distribution:** A pressurized spray system shall distribute water evenly over the coil surface with large-orifice, clog resistant spray nozzles that are threaded for easy removal. The distribution header shall be self-draining, with removable corrosion resistant PVC branch arms.

**Drift Eliminators:** Drift eliminators shall be 17 mil thick PVC with a minimum of three changes in air direction, and shall limit drift losses to 0.001% or less of the design recirculating water flow rate. Eliminators shall be easily removable for inspection.

**Access:** Large rectangular access doors with minimum 24" wide and 48" tall opening shall be located on exterior ends of the unit.

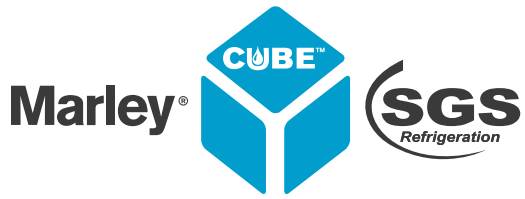

# Cube BTC Evaporative Condenser

**ENGINEERING DATA AND  
SPECIFICATIONS**

**SGS REFRIGERATION, INC.**

827 W. PROGRESS DRIVE

DIXON, IL 61021 USA

P: 815 284 2700

[sales@sgsrefrigeration.com](mailto:sales@sgsrefrigeration.com)

[sgsrefrigeration.com](http://sgsrefrigeration.com)

In the interest of technological progress, all products are subject to design and/or material change without notice

ISSUED 05/2015 CUBE\_BTC-TS-15A

COPYRIGHT © 2015 SGS Refrigeration, Inc.

Marley is a registered trademark of SPX Corporation