

**8" Series
Type "SU" Heat Exchangers
"U" Tube Design**

| | |
|--------------------|-------------------------------|
| JOB _____ | B & G REPRESENTATIVE _____ |
| UNIT TAG NO. _____ | ORDER NO. _____ DATE _____ |
| ENGINEER _____ | SUBMITTED BY _____ DATE _____ |
| CONTRACTOR _____ | APPROVED BY _____ DATE _____ |

DESCRIPTION

B&G "SU" Heat Exchangers are of the shell and tube type. The tube bundle is of "U" bend construction with tube ends expanded into a stationary tube sheet. This construction permits ample expansion or contraction for wide temperature variations. A fluid entering the tubes is heated by steam condensing in the single pass shell. Tube spacers properly support and space each tube for maximum efficiency in steam condensing and drainage.

Standard "SU" Heat Exchangers are constructed according to ASME requirements for pressures and temperature. A Manufacturers' Data Report for Pressure Vessels, Form No. U-1, as required by the provisions of the ASME Code Rules, is furnished with each unit upon request. This form is signed by an authorized inspector, holding a National Board Commission, and who is employed by an authorized inspection agency, certifying that construction conforms to the latest ASME Code for pressure vessels. The ASME "U" symbol is stamped on each vessel. In addition, each unit is registered with the National Board of Boiler and Pressure Vessel Inspectors.

RECOMMENDED "SU" HEAT EXCHANGER

MODEL NO. SU 35-2
HEATING SURFACE (SQ. FT.) _____

OPERATING DATA

TUBE SIDE SHELL SIDE

- | | | |
|---|-------|-------|
| 1. Steam Pressure..... | _____ | _____ |
| 2. Fluid Circulated..... | _____ | _____ |
| 3. Total Flow (Expressed in GPM, GPH, or lbs./hr.).. | _____ | _____ |
| 4. Temperature In/Out..... | _____ | _____ |
| 5. Heat Load BTU/hr..... | _____ | _____ |
| 6. Pressure Drop (Maximum)..... | _____ | _____ |
| 7. Fouling Factor or Percentage of Additional Surface | _____ | _____ |
| Note: Following applies only for fluids other than water. | | |
| 8. Specific Gravity..... | _____ | _____ |
| 9. Specific Heat..... | _____ | _____ |
| 10. Latent Heat..... | _____ | _____ |
| 11. Viscosity**..... | _____ | _____ |
| 12. Thermal Conductivity..... | _____ | _____ |

APPROVALS

**Expressed in Proper Units and Temperature such as centipoises @ °F.

8" Series TYPE "SU" HEAT EXCHANGERS ("U" Tube Design)

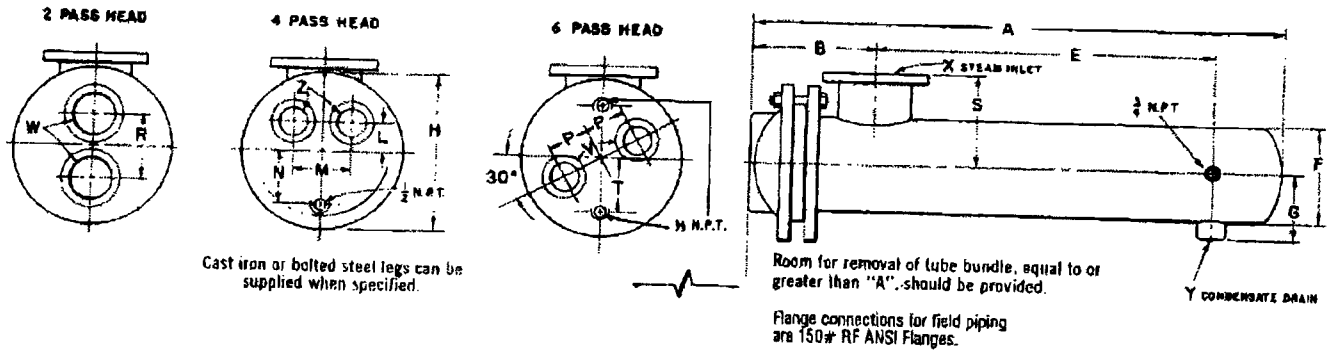

DIMENSIONS

Complete sales number consists of example: SU-86-6
 "SU" type U tube
 Shell diameter in inches
 Tube length in feet
 Number of tube passes

| UNIT NUMBER | HEAD DIMENSIONS IN INCHES | | | | | | | | | | | DIMENSIONS IN INCHES | | | | | | | | | | HEATING SURFACE SQ. FT. | | | Approx. Shpg. Wt. (lbs.) |
|-------------|---------------------------|--------|-------|--------|---|---|-------|--------|---|-------|-------|----------------------|-------|----|-------|-------|--------|-------|-----------|-----------|----|-------------------------|--------|--------|--------------------------|
| | 2 Pass | | | 4 Pass | | | | 6 Pass | | | | 2, 4 & 6 Pass | | | | | | | | | | 2 Pass | 4 Pass | 6 Pass | |
| | W | R | L | M | N | Z | P | T | V | A | B | E | F | G | H | S | X | Y | | | | | | | |
| SU82-2 | SU82-4 | SU82-6 | 3 NPT | 5 | 2 | 4 | 3 1/2 | 2 NPT | 3 | 3 1/2 | 2 NPT | 29 1/2 | 9 1/2 | 13 | 8 1/2 | 4 1/2 | 12 1/2 | 5 1/2 | 2 NPT | 1 NPT | 15 | 15 | 12 | 112 | |
| SU83-2 | SU83-4 | SU83-6 | 3 NPT | 5 | 2 | 4 | 3 1/2 | 2 NPT | 3 | 3 1/2 | 2 NPT | 41 1/2 | 9 1/2 | 25 | 8 1/2 | 4 1/2 | 12 1/2 | 6 1/2 | 2 1/2 NPT | 1 NPT | 23 | 23 | 19 | 148 | |
| SU84-2 | SU84-4 | SU84-6 | 3 NPT | 5 | 2 | 4 | 3 1/2 | 2 NPT | 3 | 3 1/2 | 2 NPT | 53 1/2 | 9 1/2 | 37 | 8 1/2 | 4 1/2 | 12 1/2 | 6 1/2 | 3 NPT | 1 NPT | 32 | 32 | 26 | 184 | |
| SU85-2 | SU85-4 | SU85-6 | 3 NPT | 5 | 2 | 4 | 3 1/2 | 2 NPT | 3 | 3 1/2 | 2 NPT | 65 1/2 | 9 1/2 | 49 | 8 1/2 | 4 1/2 | 12 1/2 | 8 1/2 | 4 FLG | 1 NPT | 41 | 41 | 33 | 220 | |
| SU86-2 | SU86-4 | SU86-6 | 3 NPT | 5 | 2 | 4 | 3 1/2 | 2 NPT | 3 | 3 1/2 | 2 NPT | 77 1/2 | 9 1/2 | 61 | 8 1/2 | 5 1/2 | 12 1/2 | 8 1/2 | 4 FLG | 1 1/2 NPT | 49 | 49 | 41 | 256 | |
| SU87-2 | SU87-4 | SU87-6 | 3 NPT | 5 | 2 | 4 | 3 1/2 | 2 NPT | 3 | 3 1/2 | 2 NPT | 89 1/2 | 9 1/2 | 73 | 8 1/2 | 5 1/2 | 12 1/2 | 8 1/2 | 4 FLG | 1 1/2 NPT | 58 | 58 | 48 | 292 | |
| SU88-2 | SU88-4 | SU88-6 | 3 NPT | 5 | 2 | 4 | 3 1/2 | 2 NPT | 3 | 3 1/2 | 2 NPT | 101 1/2 | 9 1/2 | 85 | 8 1/2 | 5 1/2 | 12 1/2 | 8 1/2 | 6 FLG | 1 1/2 NPT | 67 | 67 | 55 | 328 | |
| SU89-2 | SU89-4 | SU89-6 | 3 NPT | 5 | 2 | 4 | 3 1/2 | 2 NPT | 3 | 3 1/2 | 2 NPT | 113 1/2 | 9 1/2 | 97 | 8 1/2 | 5 1/2 | 12 1/2 | 8 1/2 | 6 FLG | 1 1/2 NPT | 75 | 75 | 62 | 364 | |

Dimensions are subject to change. If exact dimensions are needed for layout, write for certified prints.

DESIGN PRESSURES—ASME CONSTRUCTION CAST IRON & BRASS UNITS

| DESIGN PRESSURES* | | | | DESIGN TEMPERATURES* | |
|-------------------|---------|------------|---------|----------------------|-------|
| TUBE SIDE | | SHELL SIDE | | TUBE & SHELL SIDE | |
| DESIGN | TEST | DESIGN | TEST | CAST IRON | BRASS |
| 150 psi | 300 psi | 150 psi | 300 psi | 375 F | 300 F |

*For design pressures and temperatures higher than shown or materials of construction not shown, consult B & G Representative.

MATERIALS*

| PART | STANDARD CAST IRON UNIT | BRASS UNIT |
|---------------|-------------------------|---------------------|
| | 2, 4 & 6 Pass | 2 & 4 Pass |
| Head | Cast Iron | Cast Brass |
| Shell | Steel | Steel |
| Tube Sheet | Steel | Rolled Naval Brass |
| Tubing | Copper 3/4" O.D. | Copper 3/2" O.D. |
| Tube Supports | Steel | Steel |
| Nuts & Bolts | Steel | Steel |

TYPICAL INSTALLATION OF "SU" HEAT EXCHANGER

Steam hammer can cause serious damage to the tubes of any Heat Exchanger. A careful consideration of the following points before an installation is made can prevent costly repairs which may be caused by steam hammer.

- A vacuum breaker and/or vent, should be used in accordance with the type of steam system installed.
- The proper trap for the steam system installed should be used.
- The trap and the condensate return line to the trap should be properly sized for the total capacity of the converter.
- The trap should be sized for the pressure at the trap, not the inlet pressure to the steam controller.

CAUTION: A properly sized relief valve must be installed on the heated water side to protect heat exchangers from possible damage due to volumetric expansion.

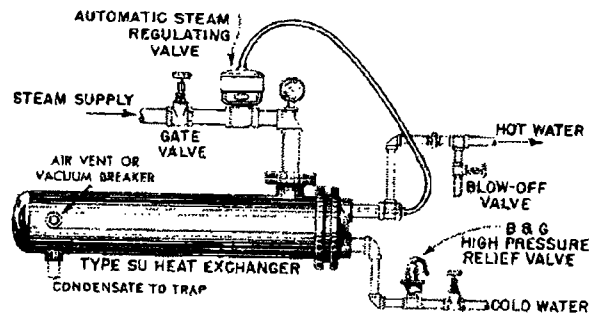

For further information, contact ITT Bell & Gossett Heat Transfer Products, 175 Standard Parkway, Cheeklowaga, NY 14227, Phone: (716) 862-4171 Facsimile: (716) 862-4176.

ITT Bell & Gossett
 ITT Fluid Technology Corporation