

2004 McQuay Air Cooled Chiller 130 Ton Model AGZ-130BS

Mfg: McQuay

Model: AGZ-130BS

Stock No. MQI201.100

Serial No. STNE04109521

2004 McQuay Air Cooled Chiller 125 Ton.

- Model AGZ-130BS.
- S/N STNE04109521
- 460 volts, 60 H.
- With 6 scroll compressors of minimum temperature.

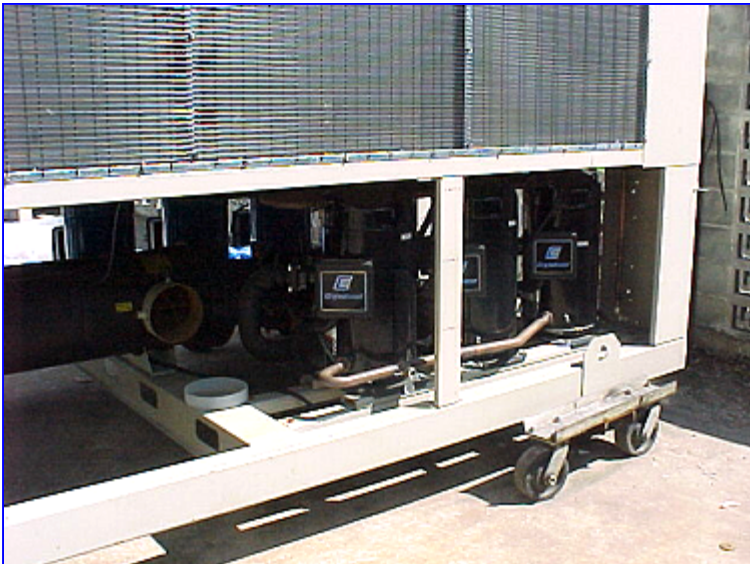
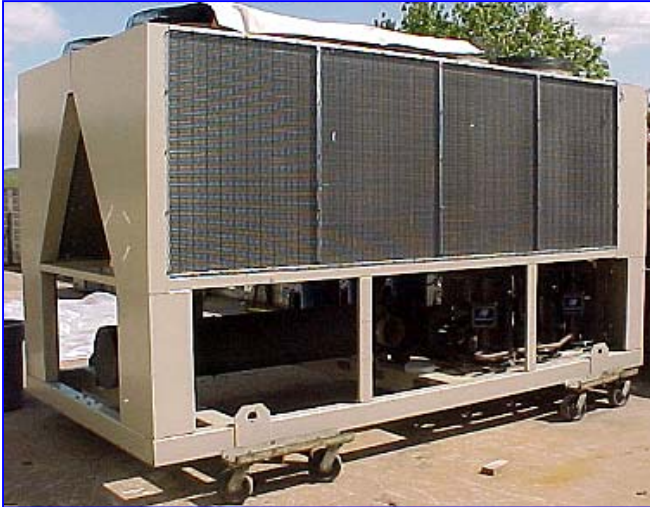

Air-Cooled Scroll Compressor Chiller

AGZ 010-AS – AGZ 130-BS/BH, Packaged Chiller
AGZ 010-AM – AGZ 130-BM/BB, Chiller with Remote Evaporator
60 Hertz, R-22



Model AGZ 026B through AGZ 130B Two-Circuit Chiller

(4-Fan Model Illustrated)

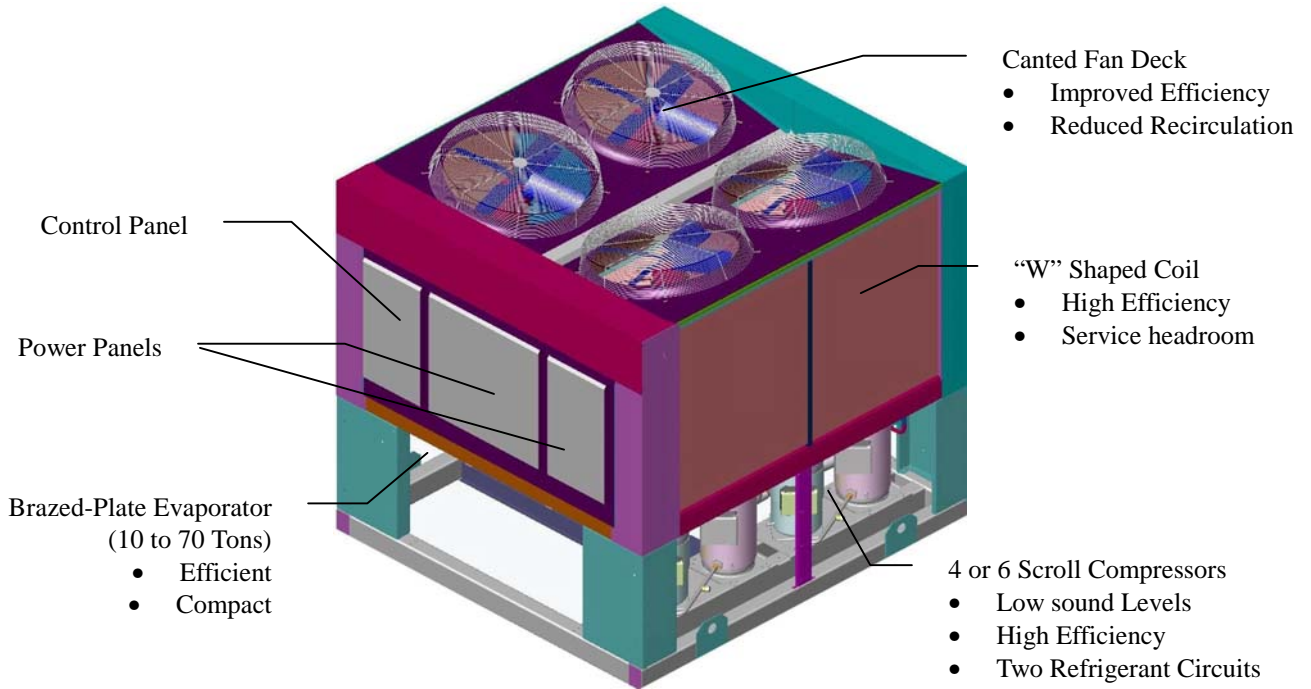

Model AGZ 010A through AGZ 034A, Single Circuit Chiller

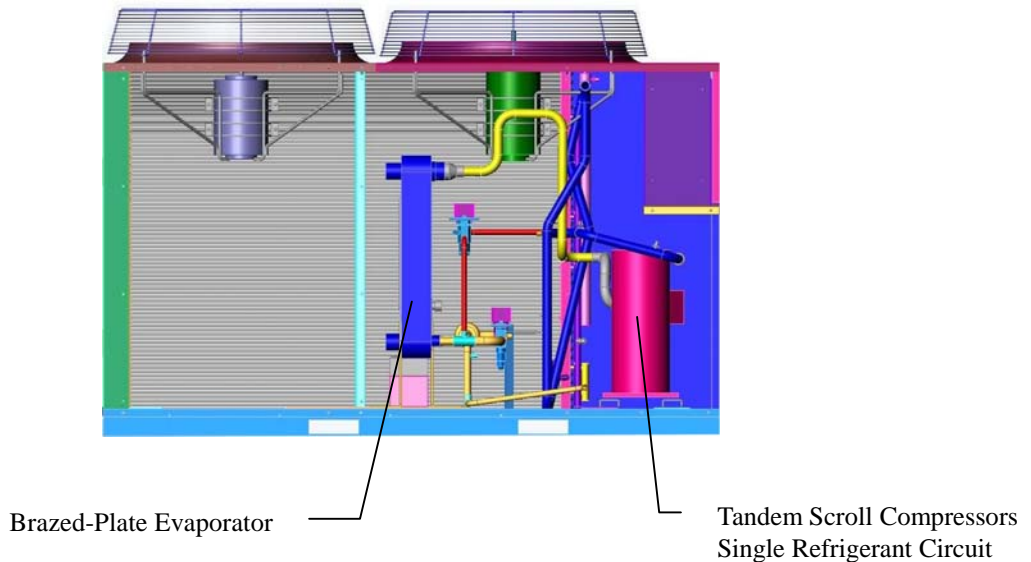

Cover Pictures: The upper unit is a Model AGZ 034A, 34 ton chiller. The lower unit is a Model AGZ 130B, 130 ton chiller with the end protective guard removed in order to view the unit interior.

Table of Contents

Introduction	4
Features and Benefits	5
Design Features	9
Control System.....	12
Optional Remote Interface Panel.....	15
Selection Procedure	16
Packaged Chiller, Model AS	16
Remote Evaporator, Model AM/BM/BB.....	18
Application Adjustment Factors	20
Performance Data	25
I-P Units	25
SI Units	28
Part Load Data	31
Sound Data	32
Pressure Drop Curves	37
Electrical Data	38
Standard/High Ambient Panels.....	38
Panel Ratings.....	38
High Ambient.....	53
Physical Data	61
AGZ, Packaged	61
AGZ-M, Remote Evaporator.....	68
Dimensional Data	75
Remote Evaporators	83
Application Data	85
Operating/Standby Limits.....	96
Warranty Statement	96
Optional Features	97
Product Specification	99



LONMARK^{3.3}

Unit controllers are LONMARK certified with an optional LONWORKS communication module.



NOTE: The Model AGZ 010AM through AGZ 130BM chillers with remote evaporators are not included in the ARI Certification Program.

Manufactured in an ISO certified facility

Document Number:	Catalog AGZ-7
Issued:	March 2005
Replaces:	PM AGZ-6

Illustrations and data cover the ©2005 McQuay International product at the time of publication and we reserve the right to make changes in design and construction at anytime without notice.

®™ The following are trademarks or registered trademarks of their respective companies: BACnet from ASHRAE; LONMARK and LONWORKS from Echelon Corporation; McQuay and MicroTech II from McQuay International; Copeland's Compliant Scroll® from Copeland Corporation, Sidney, Ohio and ElectroFin from AST ElectroFin Inc.;

Introduction

The AGZ family of air-cooled scroll chillers offers a wide selection of units from 10 to 130 tons. The AGZ-A series has capacities from 10 to 34 tons with a single refrigerant circuit using a tandem set of scroll compressors. The AGZ-B series has capacities from 26 to 130 tons with dual refrigerant circuits with either two or three scroll compressors per circuit.

The AGZ series of air-cooled scroll chillers continues McQuay's legacy of high quality, high efficiency, latest technology and quiet operation. These features make the AGZ family the best overall value in air-cooled packaged chillers available today.

Efficient Operation

The AGZ units utilize R22 to meet the performance requirements of ASHRAE 90.1. With either two or three scroll compressors per refrigerant circuit, excellent part load performance is achieved.

Latest Control Technology

These units have the latest control technology through utilization of McQuay's new MicroTech II™ microprocessor. Integrating with your building automation system is easy with the Protocol Selectability™ feature using LONMARK, BACnet or Modbus network communication, requiring only the addition of a small communication module to the unit controller.

Compact Size

Our reputation for compact designs with small footprints to minimize space requirements continues to be a primary feature.

Quiet Operation

The AGZ units further enhance McQuay's reputation for low operating sound levels to make these chillers "neighborhood friendly".

Nomenclature

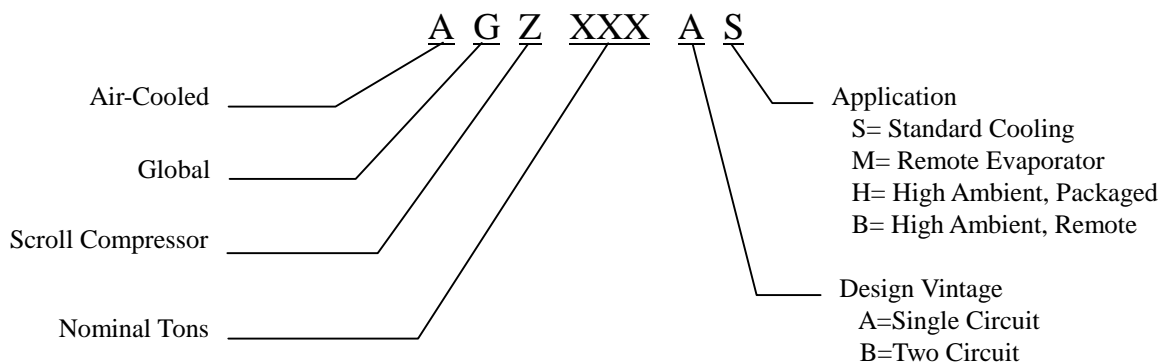

Features and Benefits

AGZ-B Chillers, Dual Circuits, 26 to 130 Tons

The AGZ-B units with dual refrigerant circuits from 26 to 130 tons offer outstanding benefits that make this product effective for a variety of applications.

High Efficiency Full Load Operation ⇒⇒Lower Energy Costs For High Loads

Utilizing new scroll compressor technology, the AGZ-B chillers meet or exceed the performance requirements of ASHRAE 90.1. All system components are selected for optimum performance, including the large condenser coil areas and large evaporator sizes. Full load EER ranges from 9.6 to 10.0.

Excellent Part Load Performance⇒⇒Lower Energy Costs for Most of the Year

By using either four or six compressors on each chiller, unloading characteristics and part load performance are outstanding. The IPLV part load values for the scroll units range from 13.4 to 14.5 EER.

Integrated part load value (IPLV) is a part load performance indicator as outlined in ARI Standard 550/590-1998. The IPLV rating compares the performance of different chillers under identical conditions. When the IPLV is listed in EER (Energy Efficiency Ratio), a higher EER will indicate that the chiller's overall performance is better.

Compact Design with Small Footprint⇒⇒Installation Flexibility and Lower Cost

McQuay AGZ-B series chillers have a reputation for a compact design and small footprint. A small footprint can save installation costs by minimizing the size of the concrete mounting pad or reduces the amount of structural steel if the unit is mounted on the roof.

Quiet Operation -- "Neighborhood friendly"⇒⇒Installation Flexibility

The AGZ chillers are designed with quiet scroll compressors. Fans are selected for good performance and lower sound levels. The attention to detail with sound is critical in the design. Small issues such as refrigerant piping, supports for piping, securing components to the structure are all important to making a quiet product. We proudly publish our sound performance.

Superior Controls -- MicroTech II™⇒⇒Efficient, Reliable Operation

Once again, McQuay has provided the latest technology in controlling the AGZ-B chillers. The new MicroTech II™ controller provides a "user friendly" environment for the operator. The control logic is designed to provide maximum efficiency, to help provide continuing operation in unusual operating conditions through proactive controls, and to provide a history of conditions to aid in problem resolutions.

Perhaps the greatest benefit is Protocol Selectability™ for integrating with your building automation system (BAS). MicroTech II™ interfaces with the BAS standard protocols through LONTALK®, BACnet® or Modbus®. See the complete control description on page 11 in this catalog.

Compare with Screw Compressor Chillers

AGZ-B Chillers, Dual Circuits, 75 to 130 Tons

The advantages of scroll compressor chillers may be overlooked when initial considerations are based on “screw compressor chillers”. The McQuay chiller philosophy is to offer ONLY scroll compressor chillers from 75 to 130 tons because of their superior value.

Why Is the Compressor Type Important?

The important issues for selecting the best chiller are the tangible benefits that have a direct impact on the owner and installer. These benefits include full load efficiency, part load performance and quiet operation. Other important issues include compact sizing for reduced installation costs, superior control with the latest control technology and the Protocol Selectability™ feature for easy integration with a building automation system. After considering the benefits, it is clear why AGZ-B chillers utilizing the new scroll compressor technology are a superior offering when compared to screw compressor air-cooled chillers from 75 to 130 tons.

Superior Part Load Performance

Perhaps the biggest benefit of AGZ compared to a typical screw compressor chiller is part load efficiency. Almost all operating hours are at part load conditions. Our engineers have designed our AGZ scroll compressor chillers for best performance at reduced load conditions.

Our advantage is simple. The AGZ approach for capacities from 75 to 130 tons is to use either four or six compressors. When reduced capacity is needed, compressors are cycled off to meet the load. Conversely, screw compressor chillers in this size range typically have only two compressors. A screw compressor relies on slide valves to reduce its capacity to meet a part load situation. Therefore, it is reasonable to expect the scroll compressor chiller with compressors cycled “off” to be more efficient at part load than a large screw compressor operating unloaded. (Refer to the IPLV discussion on the previous features and benefits page for part load efficiency comparisons. The AGZ-B offers superior part load performance compared to equally sized screw chillers.

High Efficiency Operation

Due to the optimized selection of chiller components and the large condenser coils, the full load efficiency for AGZ-B is comparable to the full load performance of other screw compressor chillers. One must remember that very few operating hours are typically at full load. The ARI Standard 550/590-1998 recognizes full load operation as ONLY 1% of the operating hours.

Quiet Operation – “Neighborhood friendly”

McQuay’s single main rotor screw compressor design is a widely acknowledged reputation for quiet operation. In contrast dual-rotor screw compressors offered by others are notoriously noisy. The AGZ-B sound levels are low and sound data is proudly displayed in this catalog. Except for McQuay’s screw chiller designs, it is difficult to find published sound data from other vendors for their air-cooled scroll chillers.

Lower installation costs - Compact design and small footprint

The AGZ-B chillers are generally smaller than comparable screw chillers. The AGZ-B’s small footprint allows for smaller mounting pads and structural steel for roof mounting applications that can reduce installation costs.

Superior Control

The AGZ-B control system utilizing the MicroTech II™ controller has the control functions expected of the most sophisticated screw chillers. Integrating a BAS system with AGZ-B chillers is more flexible than most screw chiller packages, with a choice of standard protocols including LonTalk, BACnet or Modbus. Refer to page 11 for a complete description of the control capabilities and benefits.

Chiller Simplicity and Lower Maintenance Costs

Lower maintenance cost for AGZ is a result of their simple design. General service technicians can service AGZ chillers with the simple scroll compressors. Conversely, screw compressor chillers are complex and require highly trained service technicians for service and repair. Therefore, the owner can have lower maintenance cost with AGZ for the life of the unit.

Summary

The decision to use AGZ Scroll Chillers over a screw compressor chiller offering is easy to make. The AGZ provides great performance, leading technology, quiet operation, superior control and an easy BAS integration. Installers appreciate the smaller footprints. All of these benefits are provided in a simple design with lower maintenance costs.

Figure 1, AGZ 130 (130 Tons) with Optional Full Louver Package



AGZ-A, Single Circuit, 10 to 34 Tons

Great values also come in small packages. The AGZ-A units have a single refrigerant circuit with capacities from 10 to 34 tons. Customer benefits include high efficiency operation, low sound levels, scroll compressor technology and MicroTech II™ controls.

High Efficiency Operation

The AGZ-A units meet the ASHRAE Standard 90.1 requirements for at least 9.6 EER at full load. Through the use of tandem scroll compressors and the latest control technology, excellent part load performance is also achieved.

Quiet Operation

AGZ-A units have low sound ratings through the use of scroll compressors. These compressors are housed in a sheetmetal enclosure to further reduce the levels. All units have a sound power rating of 90 dBA or less.

Superior Control with MicroTech II™

The MicroTech II™ controller is provided on the AGZ-A models providing control strategies expected of much larger chillers.

Building Automation System Integration

The MicroTech II™ controller allows for easy BAS integration through our Protocol Selectability™ feature using LONMARK, BACnet or Modbus communication. This is another advanced feature typical of larger chillers.



Design Features

McQuay AGZ Air-Cooled Chillers are a product of the McQuay commitment to offer quiet, reliable, energy efficient equipment--an approach incorporating high quality compressors, state-of-the-art coil design, and innovative packaging.

Construction

AGZ chillers are factory assembled and mounted on a heavy-gauge steel channel base. The base rails, supports and cabinetry are powder-coat painted. The base distributes the unit weight for roof loading. Varied and convenient installation is possible by virtue of the unit's small footprint.

Compressors

Copeland's Compliant Scroll® tandem compressors are used. These rugged hermetic compressors are constructed with an integral cast iron frame, cast iron scrolls, three Teflon impregnated bearings, and three oil filtration devices for each compressor.

Using Copeland's Compliant Scroll tandems and triples provides four to six steps of capacity modulation depending on model size. One to six compressors can run, depending on the load of the system, resulting in excellent part-load efficiency. Each refrigerant circuit has specially designed oil and gas equalization lines to control oil migration.

The design also offers radial and axial compliance (no tip seals), a large internal volume for liquid handling, a removable suction screen, and a rotary dirt trap and oil screen. In addition, the compressor is self-compensating for wear, handles moderate liquid slugging, and inherently yields high efficiency.

This well protected compressor includes a solid-state motor protection module, 4 individual motor-winding sensors, a patented internal discharge temperature probe, and a patented shutdown feature that prevents reverse rotation. An internal discharge check valve helps prevent shutdown noise and comes standard with high and low pressure taps with Schrader valves, a sight glass, an oil level adjustment valve, and an off cycle crankcase heater.

Units are available in 60 Hertz with voltage configurations from 208 to 575 volts (depending on size), operating at 3550 rpm.

Condenser Coils

Condenser coils have internally enhanced seamless copper tubes arranged in a staggered row pattern. The coils are mechanically expanded into McQuay lanced and rippled aluminum fins with full fin collars. A variety of optional coil material and coatings are available for corrosive atmospheres. An integral subcooler circuit provides subcooling to greatly reduce the possibility of liquid flashing. The external condenser coils are fitted with a protective wire mesh guard.

Condenser Fans and Motors

Multiple direct drive dynamically balanced propeller fans operate in formed venturi openings at low tip speeds for maximum efficiency and minimum noise and vibration. A heavy-gauge vinyl-coated fan guard protects each fan.

Each condenser fan motor (including the optional VFD fan motor) is Totally Enclosed Air Over (TEAO), heavy-duty, 3-phase with permanently lubricated ball bearings and inherent overload protection.

Evaporator

Models AGZ 010 through 070

The evaporator is a compact, high efficiency, single or dual circuit, brazed plate-to-plate type heat exchanger consisting of parallel stainless steel plates.

The evaporator is protected with an electric resistance heater and insulated with 3/4"(19mm) thick closed-cell polyurethane insulation. This combination provides freeze protection down to -20°F (-29°C) ambient air temperature. The suction line is insulated from the evaporator to the split at the compressors.

The water side working pressure is 450 psig (3102 kPa) on models 010A through 034A and 363 psig (2503 kPa) on 026B through 070B. Evaporators are designed and constructed according to, and listed by, Underwriters Laboratories (UL).

Models AGZ 075 through 130

The evaporator is direct expansion, shell-and-tube type with water flowing in the baffled shell side and refrigerant flowing through the tubes. Two independent refrigerant circuits within the evaporator serve the unit's dual refrigerant circuits.

The evaporator has a carbon steel shell and seamless high efficiency copper tubes roller expanded into a carbon steel tube sheet.

Refrigerant heads are carbon steel with multi-pass baffles to provide oil return and are removable to permit access to the tubes from either end. For water removal, 3/8" (10mm) vent and drain plugs are provided on the top and bottom of the shell.

The evaporator is wrapped with an electric resistance heater cable and insulated with 3/4" (19mm) thick vinyl nitrate polymer sheet insulation, protecting against water freeze-up at ambient air temperatures to -20°F (-29°C). An ambient air thermostat controls the heater cable. The fitted and glued in place insulation has a K factor of 0.28 Btu in/hr ft² °F at 75°F.

The refrigerant (tube) side maximum working pressure is 300 psig (2068 kPa). The water side working pressure is 152 psig (1048 kPa). Each evaporator is designed, constructed, inspected, and stamped according to the requirements of the ASME Boiler and Pressure Vessel Code. Double thickness insulation is available as an option.

On Model AGZ-M units the evaporator is shipped separately for field mounting and piping to the outdoor unit. The refrigeration piping specialties shown in Figure 2 are furnished by McQuay and installed by the installing contractor.



CAUTION

A water flow switch, or both water flow switch and water pump starter interlock, must be field installed and wired to protect against serious equipment damage from evaporator freeze-up under low water flow conditions.

Piping, Valves, and Specialties

Table 1, Piping Components Availability

UNIT	Liquid Line Shut-off	Discharge Shut-off	Suction Shut-off	Hot Gas Bypass & Shut-of Valves	LLSV, SG, TXV, F-D	
					Supplied By	Installed By
AGZ-AS, Packaged	Standard	Not Avail.	Not Avail.	Opt. (Factory Mtd).	McQuay	McQuay
AGZ-AM, Remote Evaporator	Standard	Not Avail.	Not Avail.	Opt. (Factory Mtd).	McQuay	Others
AGZ-BS/BH, Packaged	Standard	Optional	Optional	Opt. (Factory Mtd).	McQuay	McQuay
AGZ-BM/BB, Remote Evaporator	Standard	Not Avail.	Standard	Opt. (Factory Mtd).	McQuay	Others

NOTE: LLSV=Liquid Line Solenoid Valve, SG=Sight Glass, TXV=Expansion Valve, F-D=Filter-Drier

Figure 2, AGZ-BM, Remote Evaporator Piping Schematic (one circuit shown)

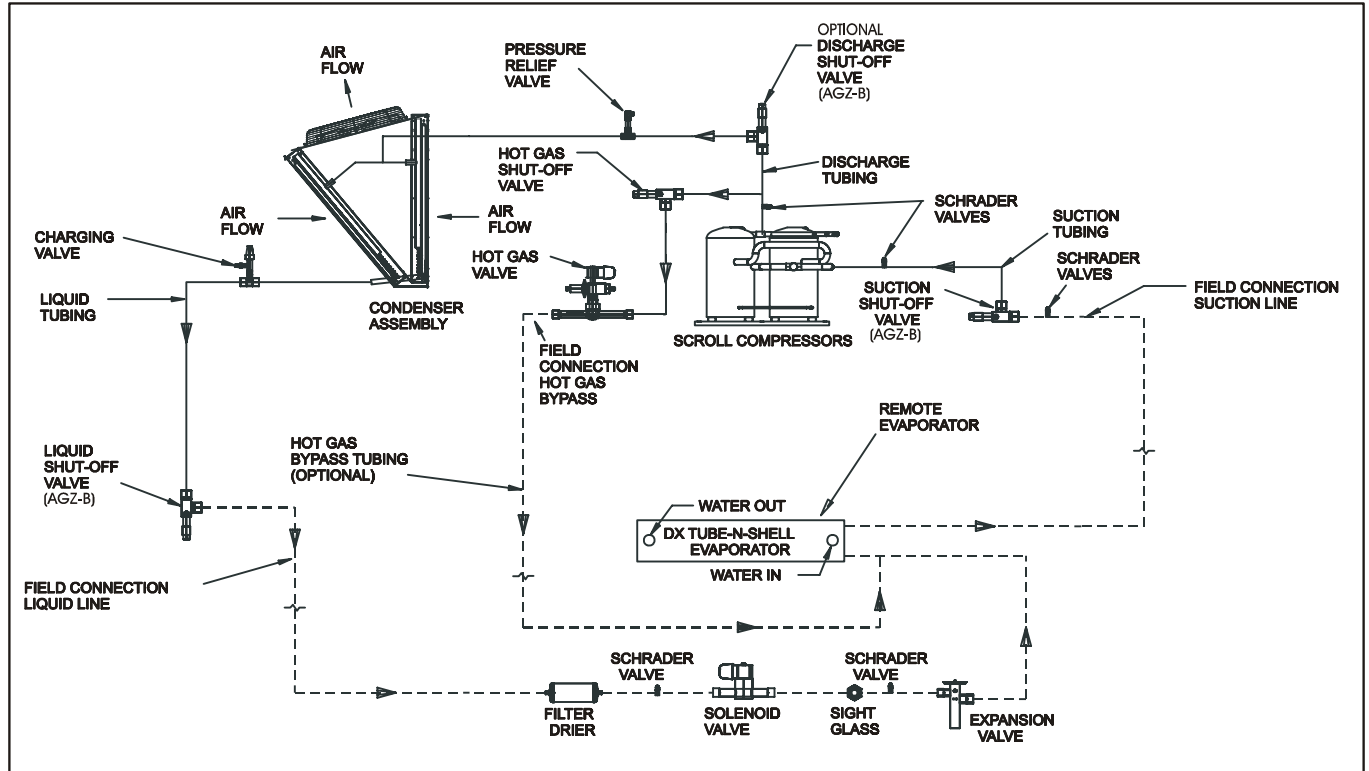

NOTES:

1. Evaporator is brazed-plate on some units.
2. Hot gas bypass is an option. The controls are factory installed and field piping is required.

Electrical Control Center

Operating and equipment protection controls and motor starting components are separately housed in a centrally located, weather resistant control panel with hinged and tool-locked doors. In addition to the MicroTech II™ controller described in the next sections, the following components are housed in the panel:

- Power terminal block, single point connection standard
- Control, input, and output terminal block
- Control transformer
- Optional disconnect switch with through-the-door handle
- Compressor motor inherent thermal and overload protection is standard
- Optional phase voltage monitor with under/over voltage and phase reversal protection
- Fan contactors with short circuit protective devices
- Optional ground fault protection (AGZ-B models only)
- The standard FanTrol™ head pressure control system controls fan staging for control of refrigerant discharge pressure. The FanTrol system cycles condenser fans based on discharge pressure and outdoor temperature and is designed for operation down to 35°F (1.7°C).
- Models 010A through 034A have the optional SpeedTrol™ control using both fan cycling and fan speed control on the lead fan per circuit and allows operation to 0°F (-18°C) outdoor temperature. Models 026B through 130B use fan VFD for operation between 35°F and 0°F (1.7°C and -18°C).
- Mechanical high pressure cutout
- Power connections are per following table:

Power Connection	Power Block	Disc. Swt.	Comp Circuit Breakers	Circuit Breakers w/ High Interr. Capacity	Panel High Short Circuit Current Rating
AGZ 010-034, Single-Point, (Std.)	Std.	Opt	Not Avail.	Opt.	Not Avail
AGZ 026-130, Single Point, (Std)	Std	Opt.	Std	Opt.	Opt
AGZ 026-130, Multi-Point, (Opt.)	Std	Opt.	Not Avail.	Opt.	Opt.

Definitions:

1. **Power Block**, An electrical device to directly accept field wiring without any disconnecting means.
2. **Disconnect Switch**, A molded case switch that accepts field wiring and disconnects main power to the entire unit or each main power supply if the multi-point power supply option is selected. This option does not provide overcurrent protection.
3. **Compressor Circuit Breakers**, A manually reset circuit breaker for each compressor, providing compressor only protection and located ahead of the contactor. Provides overcurrent protection for each compressor.
4. **Disconnect Switch with High Interrupting Capacity**, A molded case switch with high short circuit current rating (capacities are shown on page 38). One circuit breaker is provided with each electrical circuit. The circuit breaker provides overcurrent protection for each power supply.
5. **Control Panel High Short Circuit Current Rating**, (Previously known as “withstand rating”). The entire control panel is designed for short circuit current rating as shown on page 98. In the event of a short circuit, the damage is contained within the control panel enclosure.

Control System

The MicroTech II™ advanced DDC chiller controller surpasses all other microprocessor-based chiller control systems available today. This powerful, user-friendly control system provides the flexibility and performance needed for either stand-alone unit operation or the controller can be easily tied into your Building Automation System of choice using Protocol Selectability™. Protocol Selectability™ allows you to choose from open standard protocols such as BACnet®, Modbus and LonTalk® to communicate easily with the Building Automation System that best meets your facility requirements. These optional communications modules are available factory installed or can be easily field installed.

MicroTech II™’s state-of-the-art design will not only permit the chiller to run more efficiently, but will also simplify troubleshooting if a system failure occurs. Every MicroTech II™ controller is programmed and tested prior to shipment to help provide a trouble-free start-up.

Operator-friendly

The MicroTech II™ menu structure is separated into four distinct categories that provide the operator or service technician with a full description of current unit status, control parameters, and alarms. Security protection helps prevent unauthorized changing of the setpoints and unit control parameters.

MicroTech II™ continuously performs important self-diagnostic checks while monitoring system temperatures, pressures and protection devices. It will automatically shutdown a compressor, a refrigerant circuit or the entire unit if a fault occurs. The cause of the shutdown will be retained in memory and can be easily displayed in plain English or metric units for operator review. The MicroTech II™ chiller controller can also retain and display the time the fault occurred and the operating conditions that were present at the time of the fault, which is an extremely useful feature for troubleshooting. In addition to displaying alarm diagnostics, the MicroTech II™ chiller controller also provides the operator with a warning of pre-alarm conditions. Alarm notification data can also be passed to your BAS through an optional communications module.

Staging

The scroll compressors are staged on and off as a function of leaving chilled water temperature. Lead/lag is automatic and switched based on starts and operating hours.

Equipment Protection

The unit is protected in two ways: (1) by alarms that shut the unit down and require manual reset to restore unit operation and (2) by limit alarms that reduce unit operation in response to some out-of-limit condition. Shut down alarms activate an alarm signal that can be exported to a remote location. Limit alarms activate a light on the controller and do not trigger a remote alarm.

Shutdown Type Alarms

No evaporator water flow	Low evaporator pressure
High condenser pressure	Motor protection system
Ground fault protection (AGZ-B only)	Sensor failures
Phase voltage protection	Evaporator freeze protection
Outside ambient temperature	

Limit Type Alarms

- Condenser pressure stage down, unloads unit at high discharge pressures
- Low ambient lockout, shuts off unit at low ambient temperatures
- Low evaporator pressure hold, holds stage #1 until pressure rises
- Low evaporator pressure unload, shuts off stage #2

Unit Enable Selection

Enables unit operation from either local keypad, digital input, or BAS

Unit Mode Selection

Selects standard cooling, ice, glycol, or test operation mode

Analog Inputs

- Reset of leaving water temperature, 4-20 mA
- Demand limit (AGZ-B only)

Digital Inputs

- Unit off switch
- Remote start/stop
- Flow switch
- Ice mode switch, converts control operation and setpoints for ice production
- Motor protection

Digital Outputs

- Shutdown alarm; field wired, activates on an alarm condition, off when alarm is cleared
- Evaporator pump; field wired, starts pump when unit is set to start

Condenser fan control

The MicroTech II™ controller provides control of the condenser fans. The controller steps condenser fans based on discharge pressure.

Building Automation System (BAS) Interface

The following BAS protocols are supported:

BACnet/IP®	BACnet MS/TP®
BACnet Ethernet®	LonTalk® (FTT-10A)®
Modbus®	

The following functions are generally available depending on the application and protocol in use:

- | | |
|--|------------------------------------|
| Enable/disable operation | Describe each alarm when it occurs |
| Select operating mode | Set chilled water setpoint |
| Set the network limit variable | Read operating mode and status |
| Read digital and analog inputs and outputs | |

Keypad/Display

A 4-line-by-20-character/line liquid crystal display and 6-key keypad is mounted on the unit controller. Its layout is shown below.

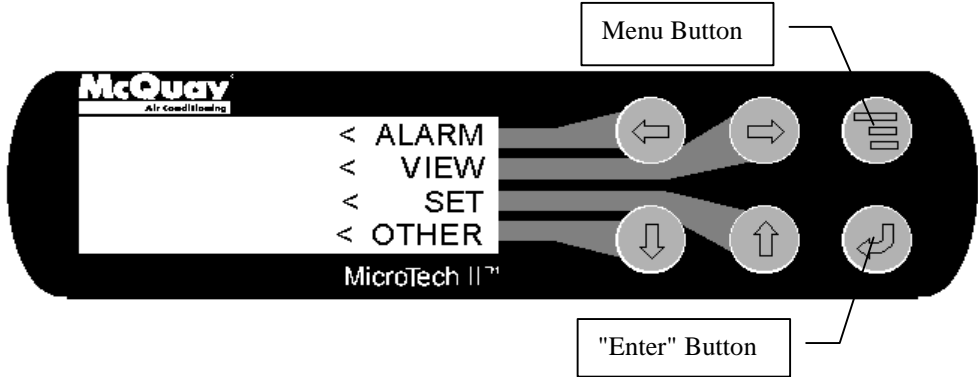

Figure 3, AGZ-B Control Panel

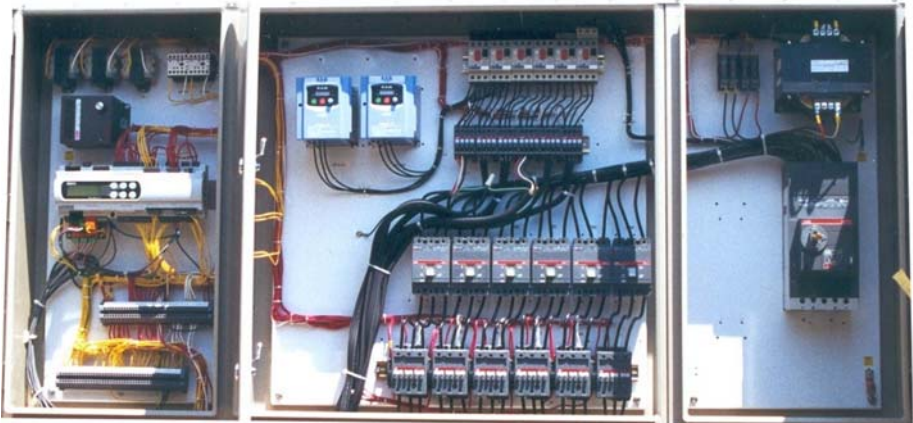

Figure 4, AGZ-A Control Panel



Optional Remote Interface Panel

In addition to the unit-mounted user interface provided with MicroTech II controls, the AGZ chillers can be individually equipped with a remote user interface. It provides convenient access to unit diagnostics and control adjustments, without having to access a rooftop or outdoor location. A separate remote panel is required for each chiller on a job site.

Each remote user interface is similar to its unit-mounted counterpart and offers the same functionality, including:

- Touch sensitive keypad with a 4 line by 20-character display format.
- Digital display of messages in English language.
- All operating conditions, system alarms, control parameters and schedules are monitored.

Features

- Can be wired up to 1,640 feet (500 meters) from the unit for flexibility in placing each remote user interface within your building.
- The main control is isolated from the remote user interface wiring so that wiring problems are less likely to damage the unit user interface.

Benefits

- Allows you to access the user interface for each unit from one location, inside the building.
- Users need to learn one format because the remote user interface is identical to the unit-mounted version.
- No additional field commissioning is required for the remote user interface.
- Can be retrofit after unit installation.
- Is fully compatible with the optional BAS communication modules.

Figure 5, Remote Interface Panel Dimensions

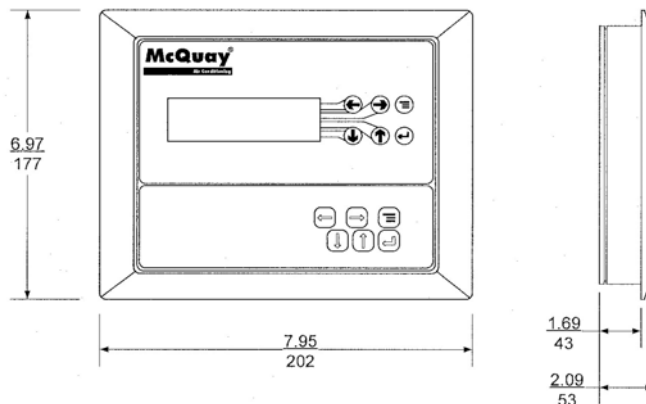

Cable and Wiring Recommendations

- No more than 1,640 feet (500 meters) of wiring can be used to connect the remote user interface to the unit.
- Power: AWG 22 twisted pair cable.
- Communications: Belden 9841 or equal AWG 22 twisted pair.

See manual *IOM MT II Remote* for wiring and installation information.

Selection Procedure

Packaged Chiller, Model AS

Selection with Inch-Pound (I-P) units

Table 13 through Table 15 cover the range of leaving evaporator water temperatures and outside ambient temperatures included under ARI 550/590-98. The tables are based on a 10 degree F (5.5 degree C) temperature drop through the evaporator. Adjustment factors for applications having other than a 10 degree F (5.5 degree C) drop can be found in Table 6 and Table 7. The minimum leaving chilled water temperature setpoint without glycol is 40°F (4°C). For brine selections, see Table 2 through Table 5 for glycol adjustment factors. Ratings are based on a 0.0001 ft² x hr x °F/Btu fouling factor in the evaporator at sea level operation. For other fouling factors, different Delta-Ts, or altitude correction factors see Table 6 and Table 7. For applications outside the catalog ratings contact your local McQuay sales representative.

Selection example

Given:

50 tons minimum
95°F ambient temperature
120 gpm, 54°F to 44°F chilled water
0.0001 evaporator fouling factor

1. From Table 14, an AGZ 055B at the given conditions will produce 52.2 tons with a unit kW input of 63.6 and a unit EER of 9.9.
2. Use the following formula to calculate any unknown elements.

$$\frac{\text{tons} \times 24}{\text{°F}} = \text{gpm} \quad (\text{water only})$$

3. Determine the evaporator pressure drop. Using Figure 9, enter at 120 gpm and follow up to the AGZ 055B line intersect. Read horizontally to obtain an evaporator pressure drop of 2.7 feet of water.

Selection example using ethylene glycol

Given:

44 tons minimum
95°F ambient air temperature
54°F - 44°F chilled water temperature
0.0001 evaporator fouling factor
Protect from freezing down to 0°F

1. From Table 1, select an ethylene glycol concentration of 40% to protect against freezing at 0°F.
2. At 40% ethylene glycol, the adjustment factors are: Capacity = 0.980, kW = 0.992, GPM = 1.132, pressure drop = 1.557
3. Select the AGZ 050B from Table 14 and correct with 40% ethylene glycol factors.
4. Correct capacity = 0.980 X 47.0 tons = 46.1 tons
5. Correct compressor kW = 0.992 X 56.6 kW = 56.1 kW
6. Calculate chilled water flow:

$$\text{Water flow (at corrected capacity)} = \frac{46.1 \text{ tons} \times 24}{10 \text{°F}} = 110.6 \text{ gpm}$$

$$\text{Glycol flow (at 40\% solution)} = 1.132 \times 110.6 \text{ gpm} = 125.2 \text{ gpm}$$

Determine the evaporator pressure drop. Using Figure 9, enter at 110.6 gpm (water) and follow up to the AGZ 050B line intersect. Read horizontally to obtain an evaporator pressure drop of 2.4 feet. Correct the pressure drop for 40% solution = $1.557 \times 2.4 \text{ feet} = 3.7 \text{ feet}$ for ethylene glycol.

Selection with SI units

Table 16 through Table 18 cover a range of leaving evaporator water temperatures and outside ambient temperatures. The tables are based on a 5°C temperature drop through the evaporator. The minimum leaving chilled water temperature setpoint without glycol is 4.5°C. For brine selections, see Table 2 through Table 5 for glycol adjustment factors. Ratings are based on a $0.0176 \text{ m}^2 \times \text{°C/kW}$ fouling factor in the evaporator at sea level operation. For other fouling factors, derates for different Delta-Ts, or altitude correction factors see Table 6 or Table 7. For applications outside the catalog ratings contact your local McQuay sales representative.

Selection example

Given:

200 kW minimum
 35°C ambient air temperature
 9 L/s, 12°C - 7°C chilled water
 0.0176 evaporator fouling factor

1. From Table 17, an AGZ 060B at the given conditions will produce 203.0 kW with a unit kW input of 70.7 and a COP of 2.87.
2. Use the following formula to calculate any missing elements:

$$\frac{\text{kW}}{4.18 \times \text{°C}} = \text{L/s} \quad (\text{water only})$$

3. Determine the evaporator pressure drop. Using Figure 9, enter at 9.0 L/s and follow down to the AGZ 060B line intersect. Read horizontally to obtain an evaporator pressure drop of 10.7 kPa.

Selection example using ethylene glycol

Given: 180 kW minimum
 35°C ambient air temperature
 12°C - 7°C chilled water temperature
 0.0176 evaporator fouling factor
 Protect against freezing down to -18°C

1. From Table 1, select an ethylene glycol concentration of 40% to protect against freezing.
2. At 40% ethylene glycol, the adjustment factors are: Capacity = 0.980, kW = 0.992, GPM = 1.132, pressure drop = 1.557
3. Select the AGZ 055B and from Table 17 and correct with 40% ethylene glycol factors.
4. Correct capacity = $0.980 \times 185.7 \text{ kW} = 182.0 \text{ kW}$
5. Correct compressor kW = $0.992 \times 63.7 \text{ kW} = 63.2 \text{ kW}$
6. Calculate chilled water flow:

$$\text{Water flow (at corrected capacity)} = \frac{182.0 \text{ kW}}{4.18 \times 5 \text{°C}} = 8.7 \text{ L/s}$$

$$\text{Glycol flow (at 40\% solution)} = 1.132 \times 8.7 \text{ L/s} = 9.8 \text{ L/s}$$

7. Determine the evaporator pressure drop. Using Figure 9, enter at 8.7 L/s of water and follow up to the AGZ 055B line intersect. Read horizontally to obtain an evaporator pressure drop of 10.6 kPa.

The pressure drop for 40% solution = $1.557 \times 10.6 \text{ kPa} = 16.5 \text{ kPa}$

Remote Evaporator, Model AM/BM/BB

Inch-Pound (I-P) Units

Since the AGZ-AM/BM units always include a specific remote heat exchanger, the ratings are based on leaving chilled water temperature and ambient air temperature with correction for the effect of the interconnecting refrigerant piping.

Table 13 through Table 15 cover the range of leaving evaporator water temperatures and outside ambient temperatures included under ARI 550/590-98. The tables are based on a 10 degree F (5.5 degree C) temperature drop through the evaporator. Adjustment factors for applications having other than a 10 degree F (5.5 degree C) drop can be found in Table 6 or Table 7. The minimum leaving chilled water temperature setpoint without glycol is 40°F (4°C). For brine selections, see Table 2 through Table 5 for glycol adjustment factors. Ratings are based on a 0.0001 ft² x hr x °F/Btu fouling factor in the evaporator at sea level operation. For other fouling factors, different Delta-Ts, or altitude correction factors see Table 6 or Table 7. For applications outside the catalog ratings contact your local McQuay sales representative.

The length and configuration of the field installed interconnecting refrigerant piping will affect the system capacity. Derates based on equivalent length of line are given in Table 12.

The steps for selecting an AGZ-AM/BM/BB are as follows:

1. Add 3% to the required cooling capacity (to approximate the effect of the correction factors to be determined) and make a preliminary unit selection from Table 13 through Table 15.
2. Divide the required capacity by the appropriate capacity correction factors: glycols from Table 2 through Table 5, altitude, chilled water Delta T, or fouling factor from Table 6 or Table 7, and refrigerant piping derate from Table 12 as explained in step 3 below.
3. Determine the suction line size by first summing the equivalent feet (from Table 8) of all the fittings (use a sketch of the piping layout) and adding the sum of these fitting losses to the actual linear feet of tubing. This will equal the total equivalent feet. (To use the equivalent feet Table 8, start with the unit suction connection size from Table 11 and correct if required.)
4. If the unit rated capacity in the tables is less than the corrected required capacity, redo the selection with the next larger unit. In most cases the line size will be the unit connection size. If the selection is satisfactory, correct the power (if applicable) and determine water pressure drop.

Selection example

English Units

Given:

40 tons required capacity
 95°F ambient temperature
 Cool 100 gpm from 54°F to 44°F
 0.0001 evaporator fouling factor
 2,000 foot altitude

1. Add 3% to the required capacity for approximate derate: $42 \times 1.03 = 43.3$ tons. From Table 14 an AGZ-045B at the given conditions will produce 42.5 tons with a unit kW input of 51.7 and a unit EER of 9.9.
2. Determine derate factors:
 - Altitude correction from Table 6:
0.998 Capacity, 1.009 Power
3. Piping correction:
 - Assume 1 5/8" suction line based on connection size in Table 10.
 - (3) 90° Standard ells $3 \times 4 \text{ ft} = 12 \text{ ft}$
 - Plus actual linear feet 70 ft
 - Total Equivalent Feet 82 ft
 - Check Table 9 and find that 1 5/8" is maximum size for oil carry.
 - This means that the 1 5/8 riser will be satisfactory.
 - The capacity correction factor from Table 12 is 0.980.
4. The corrected capacity of the AGZ is: $42.5 \text{ tons} \times 0.998\{\text{altitude}\} \times 0.98\{\text{piping}\} = 41.5 \text{ tons}$
 This satisfies the 40 ton requirement.
5. Correct the unit power required: $51.7 \text{ kW} \times 1.009\{\text{altitude}\} = 52.2 \text{ kW}$.
6. Calculate the unit EER based on the correct capacity and power:

$$\text{EER} = (41.5 \text{ tons} \times 12,000) / (52.2 \text{ kW} \times 1,000) = 9.5$$
7. Determine the evaporator pressure drop. Enter the pressure drop curves (Figure 9) at 100 gpm and read up to AGZ 045, read over to pressure drop of 2.6 ft.

Figure 6, Sample Piping Layout

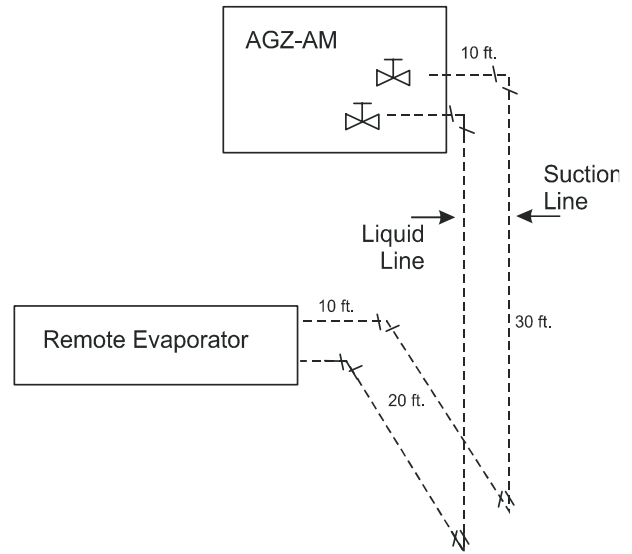

Selection example, SI Units

The selection procedure for Metric units is identical to English except that metric data and tables are used.

Application Adjustment Factors

NOTE:

Due to different performance characteristics, the application factors shown in the following tables are separated into brazed-plate evaporators (Models AGZ 010A through 070B) and shell-and-tube evaporators (Models 075B through 130B).

Ethylene and Propylene Glycol Factors

AGZ units can operate with a leaving chilled fluid temperature range of 20°F (-6°C) to 60°F (10°C). A glycol solution is required when leaving chilled fluid temperature is below 40°F (4.6°C). The use of glycol will reduce the performance of the unit depending on concentration.

Altitude Correction Factors

Performance tables are based at sea level. Elevations other than sea level affect the performance of the unit. The decreased air density will reduce condenser capacity consequently reducing the unit's performance. For performance at elevations other than sea level refer to Table 3.

Evaporator Temperature Drop Factors

Performance tables are based on a 10°F (5°C) temperature drop through the evaporator. Adjustment factors for applications with temperature ranges from 6°F to 16°F (3.3°C to 8.9°C) are in Table 3. Temperature drops outside this 6°F to 16°F (3.3°C to 8.9°C) range can affect the control system's capability to maintain acceptable control and are not recommended.

The maximum water temperature that can be circulated through the evaporator in a non-operating mode is 100°F (37.8°C).

Table 2, Ethylene Glycol Factors for Models AGZ 010A to 070B

% E.G.	Freeze Point		Capacity	Power	Flow	PD
	°F	°C				
10	26	-3.3	0.998	0.998	1.036	1.097
20	18	-7.8	0.993	0.997	1.060	1.226
30	7	-13.9	0.987	0.995	1.092	1.369
40	-7	-21.7	0.980	0.992	1.132	1.557
50	-28	-33.3	0.973	0.991	1.182	1.791

Table 3, Propylene Glycol Factors for Models AGZ 010A to 070B

% P.G.	Freeze Point		Capacity	Power	Flow	PD
	°F	°C				
10	26	-3.3	0.995	0.997	1.016	1.100
20	19	-7.2	0.987	0.995	1.032	1.211
30	9	-12.8	0.978	0.992	1.057	1.380
40	-5	-20.6	0.964	0.987	1.092	1.703
50	-27	-32.8	0.952	0.983	1.140	2.251

NOTE: Ethylene and propylene glycol ratings are outside the scope of ARI Standard 550/590-98 certification program.

Table 4, Ethylene Glycol Factors for Models AGZ 075B to 130B

% E.G.	Freeze Point		Capacity	Power	Flow	PD
	°F	°C				
10	26	-3.3	0.994	0.998	1.038	1.101
20	18	-7.8	0.982	0.995	1.063	1.224
30	7	-13.9	0.970	0.992	1.095	1.358
40	-7	-21.7	0.955	0.987	1.134	1.536
50	-28	-33.3	0.939	0.983	1.184	1.755

Table 5, Propylene Glycol Factors for Models AGZ 075B to 130B

% P.G.	Freeze Point		Capacity	Power	Flow	PD
	°F	°C				
10	26	-3.3	0.988	0.996	1.019	1.097
20	19	-7.2	0.972	0.992	1.035	1.201
30	9	-12.8	0.951	0.987	1.059	1.351
40	-5	-20.6	0.926	0.979	1.095	1.598
50	-27	-32.8	0.906	0.974	1.142	2.039

NOTE: Ethylene and propylene glycol ratings are outside the scope of ARI Standard 550/590-98 certification program.

Fouling Factor

Performance tables are based on water with a fouling factor of

$$0.0001 \text{ ft}^2 \times \text{hr} \times \text{°F} / \text{BTU} \quad \text{or} \quad (0.0176 \text{ m}^2 \times \text{°C} / \text{kW}) \text{ per ARI 550/590-98.}$$

As fouling is increased, performance decreases. For performance at other than 0.0001 (0.0176) fouling factor refer to Table 6 or Table 7. Foreign matter in the chilled water system will adversely affect the heat transfer capability of the evaporator and could increase the pressure drop and reduce the water flow. Maintain proper water treatment to provide optimum unit operation.



Table 6, Capacity and Power Derates, Models AGZ 010 to 070

Altitude	Chilled Water Delta T		Fouling Factor							
			0.0001 (0.0176)		0.00025 (0.044)		0.00075 (0.132)		0.00175 (0.308)	
	°F	°C	Cap.	Power	Cap.	Power	Cap.	Power	Cap.	Power
Sea Level	6	3.3	0.978	0.993	0.975	0.991	0.963	0.987	0.940	0.980
	8	4.4	0.989	0.996	0.986	0.994	0.973	0.990	0.950	0.983
	10	5.6	1.000	1.000	0.996	0.999	0.984	0.994	0.961	0.987
	12	6.7	1.009	1.003	1.005	1.001	0.993	0.997	0.969	0.990
	14	7.7	1.018	1.004	1.014	1.003	1.002	0.999	0.978	0.991
	16	8.9	1.025	1.007	1.021	1.006	1.009	1.001	0.985	0.994
2000 feet	6	3.3	0.977	1.001	0.973	1.000	0.961	0.996	0.938	0.989
	8	4.4	0.987	1.006	0.984	1.004	0.971	1.000	0.948	0.993
	10	5.6	0.998	1.009	0.995	1.007	0.982	1.003	0.959	0.996
	12	6.7	1.007	1.011	1.004	1.010	0.991	1.006	0.967	0.998
	14	7.7	1.014	1.014	1.011	1.013	0.998	1.009	0.974	1.001
	16	8.9	1.022	1.016	1.018	1.014	1.005	1.010	0.981	1.003
4000 feet	6	3.3	0.973	1.011	0.970	1.010	0.957	1.006	0.935	0.998
	8	4.4	0.984	1.014	0.980	1.013	0.968	1.009	0.945	1.001
	10	5.6	0.995	1.019	0.991	1.017	0.979	1.013	0.955	1.005
	12	6.7	1.004	1.021	1.000	1.020	0.987	1.016	0.964	1.008
	14	7.7	1.011	1.024	1.007	1.023	0.994	1.018	0.971	1.011
	16	8.9	1.018	1.027	1.014	1.026	1.002	1.021	0.978	1.014
6000 feet	6	3.3	0.969	1.021	0.966	1.020	0.954	1.016	0.931	1.008
	8	4.4	0.980	1.026	0.977	1.024	0.964	1.020	0.942	1.013
	10	5.6	0.989	1.029	0.986	1.027	0.973	1.023	0.950	1.015
	12	6.7	0.998	1.033	0.995	1.031	0.982	1.027	0.959	1.020
	14	7.7	1.007	1.036	1.004	1.034	0.991	1.030	0.967	1.022
	16	8.9	1.014	1.037	1.011	1.036	0.998	1.031	0.974	1.024

Table 7, Capacity and Power Derates, Models AGZ 075 to 130

Altitude	Chilled Water Delta T		Fouling Factor							
			0.0001 (0.0176)		0.00025 (0.044)		0.00075 (0.132)		0.00175 (0.308)	
	°F	°C	Cap.	Power	Cap.	Power	Cap.	Power	Cap.	Power
Sea Level	6	3.3	0.990	0.997	0.976	0.994	0.937	0.983	0.868	0.964
	8	4.4	0.994	0.998	0.981	0.995	0.942	0.984	0.872	0.965
	10	5.6	1.000	1.000	0.987	0.996	0.947	0.986	0.877	0.967
	12	6.7	1.005	1.001	0.991	0.997	0.951	0.986	0.881	0.968
	14	7.7	1.009	1.002	0.995	0.998	0.955	0.987	0.884	0.968
	16	8.9	1.013	1.004	1.000	1.000	0.960	0.989	0.889	0.970
2000 feet	6	3.3	0.987	1.005	0.974	1.002	0.934	0.991	0.865	0.972
	8	4.4	0.992	1.006	0.979	1.003	0.940	0.992	0.870	0.973
	10	5.6	0.997	1.008	0.984	1.004	0.944	0.994	0.875	0.975
	12	6.7	1.002	1.009	0.989	1.005	0.949	0.994	0.879	0.975
	14	7.7	1.007	1.011	0.993	1.007	0.953	0.996	0.883	0.977
	16	8.9	1.011	1.012	0.998	1.008	0.958	0.997	0.887	0.978
4000 feet	6	3.3	0.985	1.014	0.972	1.010	0.933	0.999	0.864	0.980
	8	4.4	0.991	1.015	0.977	1.012	0.938	1.001	0.869	0.981
	10	5.6	0.995	1.016	0.982	1.013	0.943	1.002	0.873	0.982
	12	6.7	1.000	1.018	0.987	1.014	0.947	1.003	0.877	0.984
	14	6.8	1.005	1.019	0.991	1.015	0.951	1.004	0.881	0.985
	16	8.9	1.009	1.021	0.995	1.017	0.955	1.006	0.884	0.987
6000 feet	6	3.3	0.982	1.023	0.969	1.020	0.930	1.009	0.861	0.989
	8	4.4	0.988	1.025	0.975	1.022	0.935	1.010	0.866	0.991
	10	5.6	0.992	1.026	0.979	1.022	0.940	1.011	0.870	0.992
	12	6.7	0.997	1.028	0.984	1.024	0.944	1.013	0.875	0.994
	14	7.7	1.002	1.029	0.989	1.025	0.949	1.014	0.879	0.995
	16	8.9	1.006	1.031	0.992	1.027	0.952	1.016	0.882	0.996

Table 8, Equivalent Feet for Fittings

Fitting Type	7/8	1 1/8	1 3/8	1 5/8	2 1/8	2 5/8	3 1/8
Elbows							
90° Standard	2.0	2.6	3.3	4.0	5.0	6.0	7.5
90° Long Radius	1.4	1.7	2.3	2.6	3.3	4.1	5.0
90° Street	3.2	4.1	5.6	6.3	8.2	10	12
45° Standard	0.9	1.3	1.7	2.1	2.6	3.2	4.0
45° Street	1.5	2.1	3.0	3.4	4.5	5.2	6.4
180° Bend	3.2	4.1	5.6	6.3	8.2	10	12
Tees							
Full Size	1.4	1.7	2.3	2.6	3.3	4.1	5.0
Reducing	2.0	2.6	3.3	4.0	5.0	6.0	7.5
Valves							
Globe Valve, Open	22	29	38	43	55	69	84
Gate Valve, Open	0.9	1.0	1.5	1.8	2.3	2.8	3.2
Angle Valve, Open	9.0	12	15	18	24	29	35

Table 9, Maximum Line Size (R-22) For Oil Carry Up a Suction Riser

Unit Size	AGZ 010	AGZ 013	AGZ 017	AGZ 020	AGZ 025	AGZ 029	AGZ 034
Line Size	1 1/8	1 3/8	1 5/8	1 5/8	1 5/8	2 1/8	2 1/8

Unit Size	AGZ 026	AGZ 030	AGZ 035	AGR 040	AGZ 045	AGZ 050	AGZ 055	AGZ 060	AGZ 065
Line Size	1 5/8	1 5/8	1 5/8	1 5/8	1 5/8	1 5/8	2 1/8	2 1/8	2 1/8

Unit Size	AGZ 070	AGZ 075	AGZ 085	AGZ 090	AGZ 100	AGZ 110	AGZ 120	AGZ 130
Line Size	2 5/8	2 5/8	2 5/8	2 5/8	2 5/8	2 5/8	2 5/8	2 5/8

Table 10, Recommended Liquid Line Size

Unit Model	Connection Size At Unit	Recommended Liquid Line Size				
		Up to 50 Equiv. Ft	Up to 75 Equiv. Ft	Up to 100 Equiv. Ft	Up to 125 Equiv. Ft	Up to 150 Equiv. Ft
AGZ 010AM	7/8"	7/8"	7/8"	7/8"	7/8"	7/8"
AGZ 013AM	7/8"	7/8"	7/8"	7/8"	7/8"	7/8"
AGZ 016AM	7/8"	7/8"	7/8"	7/8"	7/8"	7/8"
AGZ 020AM	7/8"	7/8"	7/8"	7/8"	7/8"	1 1/8"
AGZ 025AM	7/8"	7/8"	7/8"	7/8"	1 1/8"	1 1/8"
AGZ 029AM	7/8"	7/8"	7/8"	1 1/8"	1 1/8"	1 1/8"
AGZ 034AM	7/8"	7/8"	1 1/8"	1 1/8"	1 1/8"	1 1/8"
AGZ 026BM/BB	7/8"	7/8"	7/8"	7/8"	7/8"	7/8"
AGZ 030BM/BB	7/8"	7/8"	7/8"	7/8"	7/8"	7/8"
AGZ 035BM/BB	7/8"	7/8"	7/8"	7/8"	7/8"	7/8"
AGZ 040BM/BB	7/8"	7/8"	7/8"	7/8"	7/8"	1 1/8"
AGZ 045BM/BB	7/8"	7/8"	7/8"	7/8"	7/8"	1 1/8"
AGZ 050BM/BB	7/8"	7/8"	7/8"	7/8"	1 1/8"	1 1/8"
AGZ 055BM/BB	7/8"	7/8"	7/8"	1 1/8"	1 1/8"	1 1/8"
AGZ 060BM/BB	7/8"	7/8"	1 1/8"	1 1/8"	1 1/8"	1 1/8"
AGZ 065BM/BB	7/8"	7/8"	1 1/8"	1 1/8"	1 1/8"	1 1/8"
AGZ 070BM/BB	7/8"	7/8"	1 1/8"	1 1/8"	1 1/8"	1 1/8"
AGZ 075BM/BB	1 1/8"	1 1/8"	1 1/8"	1 1/8"	1 1/8"	1 1/8"
AGZ 085BM/BB	1 1/8"	1 1/8"	1 1/8"	1 1/8"	1 1/8"	1 1/8"
AGZ 090BM/BB	1 1/8"	1 1/8"	1 1/8"	1 1/8"	1 1/8"	1 3/8"
AGZ 100BM/BB	1 1/8"	1 1/8"	1 1/8"	1 1/8"	1 3/8"	1 3/8"
AGZ 110BM/BB	1 1/8"	1 1/8"	1 1/8"	1 3/8"	1 3/8"	1 3/8"
AGZ 120BM/BB	1 1/8"	1 1/8"	1 3/8"	1 3/8"	1 3/8"	1 3/8"
AGZ 130BM/BB	1 1/8"	1 3/8"	1 3/8"	1 3/8"	1 3/8"	1 3/8"

Table 11, Recommended Horizontal or Downflow Suction Line Size

Unit Model	Connection Size At Unit	Recommended Suction Line Sizes				
		Up to	Up to	Up to	Up to	Up to
		50 Equiv. Ft	75 Equiv. Ft	100 Equiv. Ft	125 Equiv. Ft	150 Equiv. Ft
AGZ 010AM	1 1/8"	1 1/8"	1 3/8"	1 3/8"	1 5/8"	1 5/8"
AGZ 013AM	1 1/8"	1 3/8"	1 5/8"	1 5/8"	1 5/8"	1 5/8"
AGZ 016AM	1 5/8"	1 5/8"	1 5/8"	1 5/8"	2 1/8"	2 1/8"
AGZ 020AM	1 5/8"	1 5/8"	1 5/8"	2 1/8"	2 1/8"	2 1/8"
AGZ 025AM	1 5/8"	1 5/8"	2 1/8"	2 1/8"	2 1/8"	2 1/8"
AGZ 029AM	2 1/8"	2 1/8"	2 1/8"	2 1/8"	2 1/8"	2 5/8"
AGZ 034AM	2 1/8"	2 1/8"	2 1/8"	2 5/8"	2 5/8"	2 5/8"
AGZ 026BM/BB	1 5/8"	1 5/8"	1 5/8"	1 5/8"	1 5/8"	1 5/8"
AGZ 030BM/BB	1 5/8"	1 5/8"	1 5/8"	1 5/8"	1 5/8"	2 1/8"
AGZ 035BM/BB	1 5/8"	1 5/8"	1 5/8"	2 1/8"	2 1/8"	2 1/8"
AGZ 040BM/BB	1 5/8"	1 5/8"	1 5/8"	2 1/8"	2 1/8"	2 1/8"
AGZ 045BM/BB	1 5/8"	1 5/8"	2 1/8"	2 1/8"	2 1/8"	2 1/8"
AGZ 050BM/BB	1 5/8"	1 5/8"	2 1/8"	2 1/8"	2 1/8"	2 1/8"
AGZ 055BM/BB	1 5/8"	2 1/8"	2 1/8"	2 1/8"	2 5/8"	2 5/8"
AGZ 060BM/BB	2 1/8"	2 1/8"	2 1/8"	2 1/8"	2 5/8"	2 5/8"
AGZ 065BM/BB	2 1/8, 2 5/8"	2 1/8"	2 1/8"	2 5/8"	2 5/8"	2 5/8"
AGZ 070BM/BB	2 5/8"	2 5/8"	2 5/8"	2 5/8"	2 5/8"	2 5/8"
AGZ 075BM/BB	2 5/8"	2 5/8"	2 5/8"	2 5/8"	2 5/8"	2 5/8"
AGZ 085BM/BB	2 5/8", 3 1/8"	2 5/8"	2 5/8"	2 5/8"	2 5/8"	2 5/8"
AGZ 090BM/BB	3 1/8"	2 5/8"	2 5/8"	2 5/8"	2 5/8"	2 5/8"
AGZ 100BM/BB	2 1/8, 2 5/8"	2 5/8"	2 5/8"	2 5/8"	2 5/8"	3 1/8"
AGZ 110BM/BB	2 5/8"	2 5/8"	2 5/8"	2 5/8"	3 1/8"	3 1/8"
AGZ 120BM/BB	2 5/8", 3 1/8"	2 5/8"	2 5/8"	3 1/8"	3 1/8"	3 1/8"
AGZ 130BM/BB	3 1/8"	2 5/8"	3 1/8"	3 1/8"	3 1/8"	3 1/8"

Note: For horizontal and vertical downflow only.

Table 12, Refrigerant Piping Derates

Unit Model	Capacity Loss Factor Due to Refrigerant Piping					
	At Unit	50 Equiv. Ft	75 Equiv. Ft	100 Equiv. Ft	125 Equiv. Ft	150 Equiv. Ft
AGZ 010AM	1.0	0.98	0.98	0.97	0.98	0.97
AGZ 013AM	1.0	0.98	0.98	0.98	0.97	0.96
AGZ 016AM	1.0	0.99	0.98	0.98	0.99	0.98
AGZ 020AM	1.0	0.98	0.97	0.98	0.98	0.97
AGZ 025AM	1.0	0.98	0.99	0.99	0.98	0.97
AGZ 029AM	1.0	0.99	0.98	0.97	0.96	0.98
AGZ 034AM	1.0	0.99	0.98	0.98	0.97	0.97
AGZ 026BM/BB	1.0	0.98	0.97	0.97	0.96	0.96
AGZ 030BM/BB	1.0	0.98	0.97	0.97	0.96	0.98
AGZ 035BM/BB	1.0	0.97	0.96	0.99	0.98	0.98
AGZ 040BM/BB	1.0	0.97	0.96	0.98	0.98	0.98
AGZ 045BM/BB	1.0	0.96	0.98	0.98	0.97	0.97
AGZ 050BM/BB	1.0	0.96	0.98	0.97	0.97	0.96
AGZ 055BM/BB	1.0	0.98	0.98	0.97	0.98	0.97
AGZ 060BM/BB	1.0	0.97	0.97	0.96	0.97	0.97
AGZ 065BM/BB	1.0	0.97	0.96	0.97	0.96	0.96
AGZ 070BM/BB	1.0	0.98	0.97	0.96	0.95	0.95
AGZ 075BM/BB	1.0	0.98	0.97	0.96	0.96	0.95
AGZ 085BM/BB	1.0	0.98	0.97	0.97	0.96	0.96
AGZ 090BM/BB	1.0	0.98	0.97	0.97	0.97	0.96
AGZ 100BM/BB	1.0	0.98	0.98	0.97	0.96	0.97
AGZ 110BM/BB	1.0	0.98	0.98	0.97	0.98	0.97
AGZ 120BM/BB	1.0	0.98	0.98	0.97	0.97	0.96
AGZ 130BM/BB	1.0	0.98	0.98	0.97	0.96	0.95

Performance Data

I-P Units

Table 13, AGZ 010A – 034A, I-P Units

AGZ Unit Size	Fan & Control Power (kW)	LWT (°F)	Ambient Air Temperature (°F)														
			75			85			95			105			115		
			Unit Tons	PWR kW	Unit EER	Unit Tons	PWR kW	Unit EER	Unit Tons	PWR kW	Unit EER	Unit Tons	PWR kW	Unit EER	Unit Tons	PWR kW	Unit EER
010	2.3	40	9.8	10.1	11.7	9.4	11.0	10.3	9.0	11.9	9.1	8.6	13.1	7.9	8.1	14.3	6.8
		42	10.2	10.2	12.0	9.8	11.1	10.7	9.4	12.0	9.4	8.9	13.1	8.2	8.4	14.4	7.0
		44	10.6	10.3	12.4	10.2	11.1	11.0	9.8	12.1	9.7	9.3	13.2	8.4	8.8	14.5	7.3
		46	11.1	10.4	12.8	10.6	11.2	11.3	10.2	12.2	10.0	9.7	13.3	8.7	9.2	14.6	7.5
		48	11.5	10.5	13.2	11.0	11.3	11.7	10.6	12.3	10.3	10.1	13.4	9.0	9.5	14.7	7.8
		50	11.9	10.6	13.5	11.4	11.4	12.0	11.0	12.4	10.6	10.5	13.5	9.3	9.9	14.8	8.0
013	2.3	40	13.5	13.9	11.6	12.9	15.1	10.3	12.3	16.4	9.0	11.7	17.9	7.9	11.1	19.5	6.8
		42	14.0	14.0	12.0	13.4	15.2	10.6	12.8	16.5	9.3	12.2	18.0	8.1	11.5	19.7	7.0
		44	14.5	14.1	12.3	13.9	15.3	10.9	13.3	16.7	9.6	12.6	18.2	8.3	11.9	19.8	7.2
		46	15.1	14.3	12.7	14.4	15.5	11.2	13.8	16.8	9.8	13.1	18.3	8.6	12.4	20.0	7.4
		48	15.6	14.4	13.0	15.0	15.6	11.5	14.3	17.0	10.1	13.6	18.5	8.8	12.8	20.1	7.7
		50	16.2	14.5	13.4	15.5	15.7	11.8	14.8	17.1	10.4	14.1	18.6	9.1	13.3	20.3	7.9
017	2.3	40	16.2	16.3	11.9	15.5	17.8	10.5	14.8	19.5	9.1	14.0	21.2	7.9	13.2	23.2	6.8
		42	16.8	16.5	12.3	16.1	18.0	10.7	15.3	19.6	9.4	14.5	21.4	8.1	13.7	23.4	7.0
		44	17.4	16.6	12.6	16.7	18.1	11.0	15.9	19.8	9.6	15.0	21.6	8.4	14.2	23.6	7.2
		46	18.1	16.8	12.9	17.3	18.3	11.3	16.4	19.9	9.9	15.6	21.8	8.6	14.7	23.7	7.4
		48	18.7	17.0	13.2	17.9	18.5	11.6	17.0	20.1	10.1	16.1	21.9	8.8	15.2	23.9	7.6
		50	19.3	17.1	13.5	18.5	18.6	11.9	17.6	20.3	10.4	16.7	22.1	9.0	15.7	24.1	7.8
020	3.2	40	20.8	21.2	11.8	19.9	23.0	10.4	19.0	25.0	9.1	18.0	27.2	7.9	16.9	29.6	6.8
		42	21.5	21.4	12.1	20.6	23.2	10.7	19.7	25.2	9.4	18.6	27.4	8.2	17.5	29.9	7.0
		44	22.3	21.6	12.4	21.4	23.4	11.0	20.4	25.4	9.6	19.3	27.6	8.4	18.2	30.1	7.3
		46	23.1	21.8	12.7	22.1	23.6	11.3	21.1	25.6	9.9	20.0	27.9	8.6	18.9	30.3	7.5
		48	23.9	22.0	13.1	22.9	23.8	11.6	21.9	25.8	10.2	20.7	28.1	8.9	19.5	30.6	7.7
		50	24.8	22.2	13.4	23.7	24.0	11.9	22.6	26.1	10.4	21.5	28.3	9.1	20.2	30.8	7.9
025	3.2	40	23.1	23.6	11.7	22.2	25.6	10.4	21.1	27.8	9.1	19.9	30.2	7.9	18.7	32.9	6.8
		42	24.0	23.9	12.1	23.0	25.8	10.7	21.9	28.0	9.4	20.7	30.5	8.1	19.4	33.2	7.0
		44	24.9	24.1	12.4	23.8	26.1	10.9	22.7	28.3	9.6	21.4	30.8	8.4	20.1	33.5	7.2
		46	26.0	24.1	12.9	24.7	26.4	11.2	23.5	28.6	9.9	22.2	31.1	8.6	20.9	33.8	7.4
		48	26.7	24.7	13.0	25.6	26.6	11.5	24.3	28.9	10.1	23.0	31.4	8.8	21.6	34.1	7.6
		50	27.7	25.0	13.3	26.5	26.9	11.8	25.2	29.2	10.4	23.8	31.7	9.0	22.4	34.4	7.8
029	3.2	40	28.8	28.0	12.3	27.6	30.7	10.8	26.3	33.6	9.4	25.0	36.7	8.2	23.6	40.2	7.0
		42	29.9	28.3	12.7	28.6	31.0	11.1	27.3	33.9	9.7	25.9	37.1	8.4	24.4	40.5	7.2
		44	31.0	28.6	13.0	29.7	31.3	11.4	28.3	34.2	9.9	26.8	37.4	8.6	25.3	40.9	7.4
		46	32.1	28.9	13.3	30.7	31.6	11.7	29.3	34.5	10.2	27.8	37.8	8.8	26.2	41.3	7.6
		48	33.3	29.3	13.6	31.8	31.9	12.0	30.3	34.9	10.4	28.8	38.1	9.1	27.2	41.6	7.8
		50	34.4	29.6	13.9	32.9	32.3	12.2	31.4	35.2	10.7	29.8	38.5	9.3	28.1	42.0	8.0
034	3.2	40	34.9	35.0	11.9	33.4	38.2	10.5	31.7	41.6	9.1	29.9	45.2	7.9	27.9	49.1	6.8
		42	36.1	35.4	12.2	34.6	38.6	10.7	32.9	42.1	9.4	31.0	45.7	8.1	28.9	49.6	7.0
		44	37.4	35.9	12.5	35.8	39.0	11.0	34.0	42.5	9.6	32.1	46.2	8.3	30.0	50.2	7.2
		46	38.8	36.3	12.8	37.1	39.5	11.3	35.2	43.0	9.8	33.2	46.7	8.5	31.1	50.7	7.4
		48	40.1	36.7	13.1	38.3	39.9	11.5	36.4	43.5	10.1	34.4	47.3	8.7	32.2	51.3	7.5
		50	41.5	37.2	13.4	39.6	40.4	11.8	37.7	44.0	10.3	35.6	47.8	8.9	33.3	51.8	7.7

NOTES:

1. Ratings in accordance with ARI Standard 550/590-98. Shaded and bold ratings are at ARI standard conditions.
2. Ratings based on HCFC-22, evaporator fouling factor of 0.0001, evaporator water flow of 2.4 gpm/ton and sea level altitude.
3. KW input is for the entire unit including compressors, fan motors and control power.
4. Interpolation is allowed; extrapolation is not permitted. Consult McQuay for performance outside the cataloged ratings.
5. For LWT below 40°F please refer to Application Considerations section.

Table 14, AGZ 026B – AGZ 065B

AGZ Unit Size	Fan & Control Power (kW)	LWT (°F)	Ambient Air Temperature (°F)														
			75			85			95			105			115		
			Unit Tons	PWR kW	Unit EER	Unit Tons	PWR kW	Unit EER	Unit Tons	PWR kW	Unit EER	Unit Tons	PWR kW	Unit EER	Unit Tons	PWR kW	Unit EER
026B	5.6	40	27.7	27.5	12.1	26.4	30.1	10.5	25.2	33.0	9.2	24.0	36.4	7.9	22.5	40.1	6.7
		42	28.7	27.7	12.4	27.4	30.3	10.9	26.2	33.2	9.5	24.9	36.6	8.2	23.4	40.3	7.0
		44	29.8	27.9	12.8	28.4	30.4	11.2	27.2	33.4	9.8	25.8	36.8	8.4	24.2	40.5	7.2
		46	30.8	28.0	13.2	29.5	30.6	11.5	28.1	33.6	10.0	26.7	37.0	8.7	25.1	40.7	7.4
		48	31.9	28.2	13.6	30.5	30.8	11.9	29.2	33.8	10.3	27.7	37.2	8.9	26.1	41.0	7.6
		50	33.1	28.4	14.0	31.6	31.0	12.2	30.2	34.0	10.7	28.7	37.4	9.2	27.0	41.2	7.9
030B	5.6	40	30.9	30.5	12.2	29.5	33.4	10.6	28.1	36.8	9.2	26.5	40.5	7.9	24.9	44.6	6.7
		42	32.1	30.7	12.5	30.6	33.6	10.9	29.1	37.0	9.4	27.5	40.8	8.1	25.9	44.9	6.9
		44	33.2	30.9	12.9	31.7	33.9	11.2	30.2	37.3	9.7	28.6	41.0	8.4	26.8	45.2	7.1
		46	34.4	31.1	13.3	32.8	34.1	11.6	31.3	37.5	10.0	29.6	41.3	8.6	27.8	45.5	7.3
		48	35.6	31.3	13.7	34.0	34.3	11.9	32.4	37.8	10.3	30.7	41.6	8.9	28.8	45.8	7.6
		50	36.9	31.5	14.0	35.2	34.6	12.2	33.5	38.0	10.6	31.8	41.9	9.1	29.9	46.1	7.8
035B	5.6	40	34.2	33.4	12.3	32.6	36.8	10.6	30.9	40.5	9.2	29.2	44.6	7.8	27.4	49.2	6.7
		42	35.4	33.6	12.6	33.8	37.0	10.9	32.0	40.8	9.4	30.2	45.0	8.1	28.4	49.5	6.9
		44	36.7	33.9	13.0	35.0	37.3	11.3	33.2	41.1	9.7	31.4	45.3	8.3	29.5	49.9	7.1
		46	38.0	34.2	13.3	36.2	37.6	11.6	34.4	41.4	10.0	32.5	45.6	8.5	30.5	50.3	7.3
		48	39.3	34.4	13.7	37.5	37.9	11.9	35.6	41.7	10.2	33.7	46.0	8.8	31.7	50.7	7.5
		50	40.7	34.7	14.1	38.8	38.2	12.2	36.9	42.0	10.5	34.9	46.3	9.0	32.8	51.1	7.7
040B	5.6	40	39.5	37.9	12.5	37.7	41.7	10.9	35.8	45.9	9.4	33.8	50.5	8.0	31.7	55.6	6.9
		42	41.0	38.2	12.9	39.1	41.9	11.2	37.1	46.2	9.7	35.1	50.8	8.3	32.9	55.9	7.1
		44	42.4	38.4	13.3	40.5	42.2	11.5	38.5	46.4	9.9	36.4	51.1	8.5	34.2	56.3	7.3
		46	44.0	38.7	13.6	42.0	42.5	11.9	39.9	46.7	10.2	37.7	51.5	8.8	35.4	56.7	7.5
		48	45.5	38.9	14.0	43.4	42.8	12.2	41.3	47.0	10.5	39.0	51.8	9.0	36.7	57.0	7.7
		50	47.1	39.2	14.4	45.0	43.0	12.5	42.7	47.3	10.8	40.4	52.1	9.3	38.0	57.4	8.0
045B	5.6	40	43.7	42.3	12.4	41.7	46.5	10.8	39.5	51.1	9.3	37.2	56.3	8.0	34.7	62.0	6.8
		42	45.3	42.6	12.8	43.2	46.8	11.1	41.0	51.5	9.6	38.6	56.7	8.2	36.1	62.4	7.0
		44	46.9	42.9	13.2	44.8	47.1	11.5	42.5	51.7	9.9	40.0	57.1	8.5	37.4	62.9	7.2
		46	48.6	43.3	13.5	46.4	47.5	11.8	44.0	52.2	10.2	41.5	57.5	8.7	38.8	63.4	7.4
		48	50.3	43.6	13.9	48.0	47.8	12.1	45.6	52.6	10.4	43.0	58.0	8.9	40.3	63.9	7.6
		50	52.0	44.0	14.3	49.7	48.2	12.4	47.2	53.0	10.7	44.5	58.4	9.2	41.7	64.4	7.8
050B	5.7	40	48.1	46.4	12.4	46.0	50.8	10.9	43.7	55.8	9.4	41.1	61.5	8.0	38.3	67.8	6.8
		42	49.9	46.7	12.8	47.7	51.1	11.2	45.3	56.2	9.7	42.7	61.9	8.3	39.8	68.2	7.0
		44	51.7	47.0	13.2	49.4	51.5	11.5	47.0	56.6	10.0	44.3	62.3	8.5	41.3	68.7	7.2
		46	53.5	47.4	13.6	51.2	51.8	11.8	48.7	56.9	10.3	45.9	62.7	8.8	42.9	69.2	7.4
		48	55.4	47.7	13.9	53.0	52.2	12.2	50.4	57.3	10.5	47.6	63.1	9.0	44.5	69.7	7.7
		50	57.3	48.1	14.3	54.8	52.6	12.5	52.2	57.7	10.8	49.3	63.6	9.3	46.1	70.1	7.9
055B	5.7	40	53.5	51.7	12.4	51.2	56.8	10.8	48.6	62.6	9.3	45.9	69.0	8.0	43.0	76.1	6.8
		42	55.5	52.1	12.8	53.0	57.3	11.1	50.4	63.1	9.6	47.6	69.6	8.2	44.6	76.7	7.0
		44	57.5	52.5	13.1	54.9	57.7	11.4	52.2	63.6	9.9	49.3	70.1	8.4	46.3	77.3	7.2
		46	59.5	53.0	13.5	56.9	58.2	11.7	54.1	64.1	10.1	51.1	70.7	8.7	48.0	78.0	7.4
		48	61.6	53.4	13.8	58.9	58.7	12.0	56.0	64.6	10.4	53.0	71.3	8.9	49.7	78.6	7.6
		50	63.7	53.9	14.2	60.9	59.2	12.4	58.0	65.2	10.7	54.8	71.9	9.2	51.5	79.3	7.8
060B	5.7	40	58.6	56.9	12.4	55.9	62.7	10.7	53.2	69.3	9.2	50.3	76.5	7.9	47.3	84.3	6.7
		42	60.7	57.4	12.7	58.0	63.3	11.0	55.1	69.9	9.5	52.2	77.2	8.1	49.1	85.1	6.9
		44	62.8	57.9	13.0	60.0	63.9	11.3	57.1	70.5	9.7	54.0	77.9	8.3	50.8	85.9	7.1
		46	65.0	58.5	13.3	62.2	64.5	11.6	59.1	71.2	10.0	56.0	78.6	8.5	52.7	86.7	7.3
		48	67.3	59.0	13.7	64.3	65.1	11.9	61.2	71.9	10.2	57.9	79.3	8.8	54.5	87.5	7.5
		50	69.6	59.6	14.0	66.5	65.7	12.1	63.3	72.5	10.5	60.0	80.1	9.0	56.4	88.3	7.7
065B	7.3	40	62.9	61.4	12.3	60.1	67.4	10.7	57.2	74.2	9.3	54.1	81.7	7.9	50.8	90.0	6.8
		42	65.2	62.0	12.6	62.3	68.0	11.0	59.3	74.8	9.5	56.1	82.4	8.2	52.7	90.9	7.0
		44	67.5	62.6	13.0	64.6	68.7	11.3	61.4	75.5	9.8	58.1	83.2	8.4	54.6	91.7	7.2
		46	69.9	63.2	13.3	66.9	69.3	11.6	63.6	76.2	10.0	60.2	83.9	8.6	56.7	92.5	7.3
		48	72.4	63.8	13.6	69.2	70.0	11.9	65.9	76.9	10.3	62.4	84.7	8.8	58.7	93.4	7.5
		50	74.9	64.5	13.9	71.6	70.7	12.2	68.2	77.7	10.5	64.6	85.5	9.1	60.8	94.3	7.7

NOTES:

1. Ratings in accordance with ARI Standard 550/590-98. Shaded and bold ratings are at ARI standard conditions.
2. Ratings based on HCFC-22, evaporator fouling factor of 0.0001, evaporator water flow of 2.4 gpm/ton and sea level altitude.
3. KW input is for the entire unit including compressors, fan motors and control power.
4. Interpolation is allowed; extrapolation is not permitted. Consult McQuay for performance outside the cataloged ratings.
5. For LWT below 40°F please refer to Application Considerations.

Table 15, AGZ 070B - AGZ 130B

AGZ Unit Size	Fan & Control Power (kW)	LWT (°F)	Ambient Air Temperature (°F)														
			75			85			95			105			115		
			Unit Tons	PWR kW	Unit EER	Unit Tons	PWR kW	Unit EER	Unit Tons	PWR kW	Unit EER	Unit Tons	PWR kW	Unit EER	Unit Tons	PWR kW	Unit EER
070B	7.3	40	67.2	66.3	12.2	64.2	72.7	10.6	61.0	80.0	9.1	57.6	88.1	7.8	54.0	97.2	6.7
		42	69.6	67.0	12.5	66.5	73.5	10.9	63.2	80.8	9.4	59.8	88.9	8.1	56.0	98.1	6.9
		44	72.1	67.7	12.8	68.9	74.2	11.1	65.5	81.6	9.6	62.0	89.8	8.3	58.1	99.1	7.0
		46	74.7	68.5	13.1	71.4	75.0	11.4	67.9	82.4	9.9	64.2	90.7	8.5	60.3	100.1	7.2
		48	77.3	69.2	13.4	73.9	75.8	11.7	70.3	83.3	10.1	66.5	91.7	8.7	62.5	101.1	7.4
075B	10.9	40	75.1	74.4	12.1	72.1	81.0	10.7	68.9	88.4	9.4	65.5	96.9	8.1	61.8	106.7	6.9
		42	77.6	75.0	12.4	74.5	81.6	11.0	71.3	89.1	9.6	67.8	97.7	8.3	64.0	107.5	7.1
		44	80.1	75.6	12.7	77.0	82.3	11.2	73.7	89.7	9.9	70.1	98.4	8.6	66.3	108.3	7.3
		46	82.7	76.3	13.0	79.5	82.9	11.5	76.1	90.5	10.1	72.5	99.2	8.8	68.6	109.2	7.5
		48	85.3	76.9	13.3	82.1	83.6	11.8	78.6	91.3	10.3	75.0	100.0	9.0	71.0	110.0	7.7
085B	10.9	40	81.2	80.2	12.2	78.0	87.3	10.7	74.6	95.4	9.4	70.9	104.5	8.1	67.2	114.8	7.0
		42	83.9	80.9	12.4	80.6	88.0	11.0	77.1	96.2	9.6	73.4	105.3	8.4	69.5	115.7	7.2
		44	86.6	81.6	12.7	83.2	88.8	11.2	79.6	96.9	9.9	75.9	106.2	8.6	71.9	116.7	7.4
		46	89.3	82.3	13.0	85.9	89.5	11.5	82.2	97.7	10.1	78.4	107.1	8.8	74.4	117.6	7.6
		48	92.1	83.0	13.3	88.6	90.3	11.8	84.9	98.5	10.3	81.0	107.9	9.0	76.9	118.6	7.8
090B	10.9	40	87.4	85.8	12.2	83.9	93.6	10.8	80.2	102.2	9.4	76.4	111.9	8.2	72.5	122.7	7.1
		42	90.2	86.6	12.5	86.6	94.3	11.0	82.8	103.1	9.6	79.0	112.8	8.4	75.0	123.7	7.3
		44	93.0	87.3	12.8	89.4	95.1	11.3	85.5	103.9	9.9	81.6	113.8	8.6	77.5	124.8	7.5
		46	95.9	88.1	13.1	92.2	95.9	11.5	88.3	104.8	10.1	84.2	114.7	8.8	80.1	125.9	7.6
		48	98.9	88.9	13.3	95.1	96.8	11.8	91.1	105.6	10.3	87.0	115.7	9.0	82.7	127.0	7.8
100B	14.4	40	99.7	98.5	12.1	95.5	107.7	10.6	91.0	118.1	9.2	86.2	129.8	8.0	81.0	142.9	6.8
		42	103.2	99.3	12.5	98.9	108.5	10.9	94.3	119.0	9.5	89.3	130.8	8.2	84.1	144.0	7.0
		44	106.8	100.2	12.8	102.4	109.4	11.2	97.6	119.9	9.8	92.6	131.8	8.4	87.2	145.1	7.2
		46	110.5	101.0	13.1	105.9	110.3	11.5	101.1	120.8	10.0	95.9	132.8	8.7	90.4	146.3	7.4
		48	114.3	101.9	13.5	109.6	111.2	11.8	104.6	121.8	10.3	99.3	133.8	8.9	93.7	147.4	7.6
110B	14.5	40	109.8	110.4	11.9	105.1	120.4	10.5	100.2	131.8	9.1	94.8	144.9	7.9	89.0	159.8	6.7
		42	113.6	111.5	12.2	108.9	121.6	10.7	103.8	133.0	9.4	98.3	146.1	8.1	92.4	161.2	6.9
		44	117.6	112.6	12.5	112.7	122.7	11.0	107.5	134.3	9.6	101.9	147.5	8.3	95.8	162.6	7.1
		46	121.6	113.7	12.8	116.6	123.9	11.3	111.3	135.5	9.9	105.6	148.8	8.5	99.4	164.0	7.3
		48	125.8	114.8	13.1	120.6	125.1	11.6	115.2	136.8	10.1	109.3	150.2	8.7	103.0	165.5	7.5
120B	14.5	40	132.0	116.0	13.4	124.7	126.3	11.8	119.1	138.1	10.3	113.2	151.6	9.0	106.7	167.0	7.7
		42	122.6	123.2	12.0	117.3	134.3	10.5	111.6	146.9	9.1	105.8	161.1	7.9	99.6	177.0	6.8
		44	127.0	124.4	12.2	121.5	135.6	10.7	115.7	148.3	9.4	109.7	162.7	8.1	103.4	178.8	6.9
		46	131.4	125.7	12.5	125.8	137.0	11.0	119.8	149.8	9.6	113.7	164.3	8.3	107.2	180.6	7.1
		48	136.0	127.1	12.8	130.2	138.4	11.3	124.1	151.3	9.8	117.7	165.9	8.5	111.2	182.4	7.3
130B	14.5	40	140.6	128.5	13.1	134.7	139.9	11.6	128.4	152.9	10.1	121.9	167.6	8.7	115.2	184.3	7.5
		42	145.4	129.9	13.4	139.3	141.4	11.8	132.9	154.5	10.3	126.2	169.4	8.9	119.3	186.2	7.7
		44	132.7	132.6	12.0	126.8	144.7	10.5	120.7	158.2	9.2	114.5	173.2	7.9	108.3	189.9	6.8
		46	137.3	134.0	12.3	131.3	146.2	10.8	125.0	159.8	9.4	118.6	175.0	8.1	112.3	192.0	7.0
		48	142.1	135.5	12.6	135.9	147.7	11.0	129.4	161.4	9.6	122.9	176.9	8.3	116.3	194.1	7.2
50	146.9	137.0	12.9	140.6	149.3	11.3	134.0	163.1	9.9	127.3	178.7	8.5	120.5	196.2	7.4		
50	151.9	138.5	13.2	145.4	150.9	11.6	138.7	164.9	10.1	131.8	180.7	8.8	124.8	198.4	7.6		
50	157.0	140.1	13.4	150.3	152.5	11.8	143.4	166.6	10.3	136.4	182.6	9.0	129.2	200.6	7.7		

NOTES:

1. Ratings in accordance with ARI Standard 550/590-98. Shaded and bold ratings are at ARI standard conditions.
2. Ratings based on HCFC-22, evaporator fouling factor of 0.0001, evaporator water flow of 2.4 gpm/ton and sea level altitude.
3. KW input is for the entire unit including compressors, fan motors and control power.
4. Interpolation is allowed; extrapolation is not permitted. Consult McQuay for performance outside the cataloged ratings.
5. For LWT below 40°F please refer to Application Considerations.

SI Units

Table 16, AGZ 010A through 034A, SI Units

AGZ Unit Size	Fan & Control Power	LWT (°C)	Ambient Air Temperature (°C)														
			25			30			35			40			45		
			Unit kW	PWR kW _i	Unit COP	Unit kW	PWR kW _i	Unit COP	Unit kW	PWR kW _i	Unit COP	Unit kW	PWR kW _i	Unit COP	Unit kW	PWR kW _i	Unit COP
010	2.3	5.0	35.0	10.3	3.40	33.7	11.1	3.03	32.3	12.0	2.70	30.9	13.0	2.38	29.4	14.1	2.09
		6.0	36.2	10.4	3.49	34.9	11.2	3.12	33.5	12.1	2.78	32.1	13.1	2.46	30.5	14.2	2.15
		7.0	37.5	10.5	3.59	36.2	11.3	3.21	34.8	12.2	2.86	33.3	13.2	2.53	31.7	14.3	2.22
		8.0	38.9	10.6	3.68	37.5	11.4	3.30	36.0	12.2	2.94	34.5	13.2	2.61	32.8	14.4	2.29
		9.0	40.2	10.7	3.78	38.8	11.4	3.39	37.3	12.3	3.02	35.7	13.3	2.68	34.0	14.5	2.35
		10.0	41.6	10.7	3.87	40.1	11.5	3.48	38.6	12.4	3.11	36.9	13.4	2.75	35.2	14.6	2.42
013	2.3	5.0	47.9	14.2	3.38	46.0	15.3	3.02	44.2	16.5	2.68	42.3	17.8	2.37	40.2	19.3	2.09
		6.0	49.5	14.3	3.47	47.6	15.4	3.10	45.7	16.6	2.75	43.7	17.9	2.44	41.5	19.4	2.14
		7.0	51.2	14.4	3.56	49.2	15.5	3.18	47.3	16.7	2.83	45.2	18.1	2.50	42.9	19.5	2.20
		8.0	52.9	14.5	3.64	50.9	15.6	3.26	48.9	16.8	2.90	46.7	18.2	2.57	44.4	19.7	2.26
		9.0	54.6	14.7	3.73	52.6	15.7	3.34	50.5	17.0	2.97	48.3	18.3	2.64	45.8	19.8	2.32
		10.0	56.4	14.8	3.82	54.3	15.9	3.42	52.2	17.1	3.05	49.9	18.5	2.70	47.3	19.9	2.38
017	2.3	5.0	57.7	16.7	3.46	55.3	18.1	3.07	52.9	19.5	2.71	50.4	21.2	2.39	47.9	22.9	2.10
		6.0	59.5	16.8	3.54	57.1	18.2	3.14	54.6	19.7	2.78	52.1	21.3	2.45	49.4	23.0	2.15
		7.0	61.4	17.0	3.62	59.0	18.3	3.22	56.4	19.8	2.84	53.8	21.5	2.51	51.0	23.2	2.20
		8.0	63.4	17.1	3.71	60.8	18.5	3.29	58.2	20.0	2.91	55.5	21.6	2.57	52.7	23.4	2.26
		9.0	65.3	17.3	3.79	62.7	18.6	3.37	60.0	20.1	2.98	57.2	21.8	2.63	54.3	23.6	2.31
		10.0	67.3	17.4	3.87	64.6	18.8	3.44	61.8	20.3	3.05	59.0	21.9	2.69	56.0	23.7	2.37
020	3.2	5.0	73.8	21.6	3.41	70.9	23.3	3.05	67.9	25.1	2.71	64.7	27.1	2.39	61.3	29.3	2.10
		6.0	76.2	21.8	3.50	73.2	23.5	3.12	70.2	25.3	2.78	66.9	27.3	2.45	63.4	29.5	2.16
		7.0	78.6	22.0	3.58	75.6	23.6	3.20	72.4	25.5	2.84	69.1	27.5	2.51	65.5	29.7	2.21
		8.0	81.2	22.2	3.66	78.0	23.8	3.28	74.8	25.7	2.91	71.3	27.7	2.58	67.6	29.9	2.27
		9.0	83.7	22.4	3.75	80.5	24.0	3.35	77.1	25.9	2.98	73.6	27.9	2.64	69.8	30.1	2.32
		10.0	86.4	22.6	3.83	83.0	24.2	3.43	79.5	26.1	3.05	75.9	28.1	2.70	72.0	30.3	2.38
025	3.2	5.0	82.2	24.2	3.41	79.0	25.9	3.05	75.5	27.9	2.70	71.8	30.1	2.39	67.8	32.5	2.09
		6.0	84.9	24.4	3.49	81.6	26.2	3.12	78.0	28.2	2.77	74.2	30.4	2.45	70.1	32.8	2.14
		7.0	87.9	24.5	3.59	84.2	26.4	3.19	80.6	28.4	2.84	76.6	30.6	2.51	72.5	33.0	2.20
		8.0	91.0	24.7	3.69	87.0	26.6	3.27	83.2	28.6	2.90	79.1	30.9	2.57	74.9	33.3	2.25
		9.0	93.5	25.1	3.73	89.8	26.9	3.34	85.9	28.9	2.97	81.7	31.1	2.63	77.3	33.6	2.31
		10.0	96.5	25.4	3.81	92.6	27.1	3.42	88.6	29.2	3.04	84.3	31.4	2.69	79.8	33.9	2.36
029	3.2	5.0	102.4	28.7	3.57	98.4	31.1	3.17	94.2	33.7	2.79	89.9	36.6	2.46	85.4	39.6	2.16
		6.0	105.8	29.0	3.66	101.6	31.4	3.24	97.3	34.0	2.86	92.9	36.9	2.52	88.2	40.0	2.21
		7.0	109.2	29.3	3.74	104.9	31.7	3.32	100.5	34.3	2.93	95.9	37.2	2.58	91.1	40.3	2.27
		8.0	112.8	29.5	3.82	108.3	32.0	3.39	103.7	34.6	3.00	99.0	37.5	2.64	94.0	40.6	2.32
		9.0	116.3	29.8	3.91	111.8	32.3	3.47	107.1	34.9	3.07	102.1	37.8	2.70	97.0	41.0	2.37
		10.0	120.0	30.1	3.99	115.3	32.6	3.54	110.4	35.2	3.13	105.3	38.2	2.76	100.1	41.3	2.43
034	3.2	5.0	123.8	35.9	3.46	118.8	38.7	3.07	113.5	41.8	2.71	107.7	45.1	2.39	101.4	48.6	2.09
		6.0	127.8	36.2	3.53	122.7	39.1	3.14	117.2	42.2	2.77	111.2	45.6	2.44	104.7	49.1	2.14
		7.0	131.9	36.6	3.61	126.6	39.5	3.21	120.9	42.7	2.83	114.8	46.0	2.50	108.1	49.5	2.19
		8.0	136.0	37.0	3.68	130.6	39.9	3.27	124.7	43.1	2.89	118.4	46.5	2.55	111.6	50.0	2.24
		9.0	140.3	37.4	3.76	134.6	40.3	3.34	128.6	43.5	2.95	122.1	46.9	2.60	115.1	50.5	2.28
		10.0	144.6	37.8	3.83	138.7	40.8	3.41	132.5	44.0	3.01	125.8	47.4	2.66	118.7	51.0	2.33

NOTES:

1. Ratings in accordance with ARI Standard 550/590-98.
2. Ratings based on HCFC-22, evaporator fouling factor of 0.0176, 5.6°C evaporator delta-T, and sea level altitude.
3. KW input is for the entire unit including compressors, fan motors and control power.
4. Interpolation is allowed; extrapolation is not permitted. Consult McQuay for performance outside the cataloged ratings.
5. For LWT below 5.0°C please refer to Application Considerations.

Table 17, AGZ 026B – AGZ 065B

AGZ Unit Size	Fan & Control Power	LWT (°C)	Ambient Air Temperature (°C)														
			25			30			35			40			45		
			Unit kW	PWR kW _i	Unit COP	Unit kW	PWR kW _i	Unit COP	Unit kW	PWR kW _i	Unit COP	Unit kW	PWR kW _i	Unit COP	Unit kW	PWR kW _i	Unit COP
026B	4.1	5.0	98.3	28.1	3.50	94.3	30.5	3.10	90.4	33.1	2.73	86.3	36.1	2.39	81.7	39.4	2.08
		6.0	101.5	28.3	3.60	97.4	30.6	3.18	93.4	33.3	2.81	89.2	36.3	2.46	84.4	39.6	2.14
		7.0	104.8	28.4	3.69	100.6	30.8	3.27	96.5	33.5	2.89	92.1	36.5	2.53	87.3	39.8	2.20
		8.0	108.2	28.6	3.79	103.9	31.0	3.36	99.7	33.7	2.96	95.2	36.7	2.60	90.1	40.0	2.26
		9.0	111.7	28.7	3.89	107.3	31.1	3.45	103.0	33.8	3.04	98.3	36.9	2.67	93.1	40.2	2.32
		10.0	115.3	28.9	3.99	110.8	31.3	3.54	106.3	34.0	3.12	101.5	37.1	2.74	96.2	40.5	2.38
030B	4.1	5.0	109.7	31.2	3.53	105.1	33.9	3.11	100.5	36.9	2.72	95.6	40.3	2.38	90.5	43.9	2.06
		6.0	113.3	31.3	3.62	108.6	34.1	3.19	103.8	37.1	2.80	98.9	40.5	2.44	93.5	44.2	2.12
		7.0	117.0	31.5	3.72	112.2	34.3	3.28	107.3	37.3	2.87	102.1	40.7	2.51	96.7	44.5	2.18
		8.0	120.7	31.7	3.81	115.8	34.5	3.36	110.8	37.6	2.95	105.5	41.0	2.58	99.8	44.7	2.24
		9.0	124.6	31.9	3.91	119.5	34.7	3.45	114.3	37.8	3.03	108.9	41.2	2.64	103.1	45.0	2.30
		10.0	128.5	32.2	4.01	123.3	34.9	3.53	118.0	38.0	3.10	112.4	41.5	2.71	106.4	45.3	2.36
035B	4.1	5.0	121.2	34.2	3.55	116.0	37.3	3.12	110.7	40.7	2.72	105.1	44.4	2.37	99.3	48.4	2.06
		6.0	125.2	34.4	3.64	119.8	37.5	3.20	114.3	40.9	2.79	108.6	44.7	2.43	102.7	48.8	2.11
		7.0	129.2	34.7	3.74	123.7	37.8	3.28	118.0	41.2	2.87	112.2	45.0	2.50	106.1	49.1	2.17
		8.0	133.3	34.9	3.83	127.7	38.0	3.36	121.9	41.5	2.94	115.8	45.3	2.56	109.6	49.4	2.22
		9.0	137.5	35.1	3.92	131.7	38.3	3.44	125.7	41.8	3.01	119.5	45.6	2.62	113.1	49.8	2.28
		10.0	141.8	35.4	4.01	135.9	38.6	3.53	129.7	42.0	3.08	123.3	45.9	2.69	116.8	50.1	2.34
040B	5.6	5.0	140.2	38.8	3.62	134.4	42.2	3.18	128.2	46.0	2.79	121.8	50.2	2.43	115.2	54.7	2.11
		6.0	144.8	39.0	3.72	138.8	42.5	3.27	132.4	46.3	2.86	125.9	50.5	2.50	119.1	55.0	2.17
		7.0	149.5	39.2	3.82	143.3	42.7	3.36	136.8	46.5	2.94	130.0	50.8	2.57	123.1	55.4	2.23
		8.0	154.2	39.5	3.92	147.8	43.0	3.45	141.2	46.8	3.02	134.3	51.0	2.63	127.1	55.7	2.29
		9.0	159.1	39.7	4.01	152.5	43.2	3.53	145.7	47.1	3.10	138.6	51.3	2.70	131.2	56.0	2.35
		10.0	164.1	40.0	4.11	157.3	43.5	3.62	150.3	47.3	3.17	143.0	51.6	2.77	135.5	56.3	2.41
045B	5.6	5.0	155.0	43.3	3.60	148.5	47.1	3.17	141.5	51.3	2.77	134.1	56.0	2.41	126.2	61.1	2.08
		6.0	160.0	43.6	3.70	153.4	47.4	3.25	146.2	51.6	2.85	138.6	56.3	2.48	130.5	61.5	2.14
		7.0	165.2	43.9	3.79	158.3	47.7	3.34	151.0	52.0	2.92	143.2	56.7	2.54	134.9	61.9	2.20
		8.0	170.4	44.2	3.88	163.4	48.0	3.42	155.9	52.3	2.99	147.9	57.1	2.61	139.4	62.3	2.25
		9.0	175.8	44.5	3.98	168.5	48.4	3.51	160.8	52.7	3.07	152.6	57.5	2.67	144.0	62.8	2.31
		10.0	181.3	44.8	4.07	173.8	48.7	3.59	165.9	53.0	3.14	157.5	57.9	2.74	148.7	63.2	2.37
050B	5.7	5.0	170.7	47.4	3.61	163.9	51.5	3.19	156.5	56.0	2.79	148.3	61.1	2.43	139.4	66.7	2.09
		6.0	176.3	47.7	3.70	169.3	51.8	3.27	161.6	56.3	2.87	153.3	61.5	2.50	144.2	67.2	2.15
		7.0	182.0	48.0	3.80	174.8	52.1	3.36	166.9	56.7	2.95	158.4	61.8	2.56	149.1	67.6	2.21
		8.0	187.9	48.3	3.89	180.4	52.4	3.45	172.3	57.0	3.02	163.6	62.2	2.63	154.1	68.0	2.27
		9.0	193.8	48.7	3.99	186.1	52.7	3.53	177.8	57.4	3.10	168.9	62.6	2.70	159.2	68.4	2.33
		10.0	199.9	49.0	4.09	191.9	53.1	3.62	183.4	57.7	3.18	174.3	63.0	2.77	164.4	68.8	2.40
055B	5.7	5.0	190.0	52.9	3.60	182.3	57.6	3.17	174.1	62.8	2.77	165.3	68.6	2.41	156.0	75.0	2.09
		6.0	196.2	53.3	3.69	188.2	58.0	3.25	179.8	63.3	2.84	170.8	69.1	2.47	161.3	75.5	2.14
		7.0	202.5	53.7	3.78	194.3	58.5	3.33	185.7	63.7	2.91	176.4	69.6	2.54	166.6	76.1	2.20
		8.0	208.9	54.1	3.87	200.5	58.9	3.41	191.6	64.2	2.98	182.1	70.2	2.60	172.1	76.7	2.25
		9.0	215.5	54.5	3.96	206.8	59.3	3.49	197.7	64.7	3.06	188.0	70.7	2.66	177.7	77.2	2.31
		10.0	222.2	55.0	4.05	213.3	59.8	3.57	203.9	65.2	3.13	193.9	71.2	2.73	183.4	77.8	2.36
060B	5.7	5.0	207.8	58.3	3.57	199.3	63.7	3.13	190.5	69.6	2.74	181.2	76.1	2.38	171.6	83.1	2.07
		6.0	214.5	58.8	3.66	205.8	64.2	3.21	196.7	70.1	2.80	187.1	76.7	2.44	177.2	83.8	2.12
		7.0	221.3	59.3	3.74	212.3	64.7	3.28	203.0	70.7	2.87	193.2	77.3	2.50	183.0	84.5	2.17
		8.0	228.2	59.8	3.83	219.0	65.3	3.36	209.4	71.3	2.94	199.4	78.0	2.56	188.9	85.2	2.22
		9.0	235.3	60.3	3.91	225.9	65.8	3.44	216.0	71.9	3.00	205.6	78.7	2.62	194.9	85.9	2.27
		10.0	242.5	60.9	3.99	232.8	66.4	3.51	222.7	72.5	3.07	212.1	79.3	2.68	201.0	86.7	2.32
065B	7.3	5.0	223.4	62.9	3.56	214.3	68.4	3.14	204.8	74.5	2.75	194.8	81.3	2.40	184.3	88.8	2.08
		6.0	230.6	63.4	3.64	221.3	69.0	3.21	211.5	75.1	2.82	201.2	82.0	2.46	190.4	89.5	2.13
		7.0	238.0	64.0	3.73	228.4	69.5	3.29	218.4	75.7	2.88	207.8	82.6	2.52	196.8	90.2	2.19
		8.0	245.5	64.5	3.81	235.7	70.1	3.36	225.4	76.4	2.95	214.6	83.3	2.58	203.2	91.0	2.24
		9.0	253.2	65.1	3.90	243.1	70.7	3.44	232.6	77.0	3.02	221.5	84.0	2.64	209.8	91.8	2.29
		10.0	261.0	65.7	3.98	250.7	71.4	3.52	239.9	77.7	3.09	228.5	84.8	2.70	216.5	92.5	2.35

NOTES:

1. Ratings in accordance with ARI Standard 550/590-98.
2. Ratings based on HCFC-22, evaporator fouling factor of 0.0176, 5.6°C evaporator delta-T, and sea level altitude.
3. KW input is for the entire unit including compressors, fan motors and control power.
4. Interpolation is allowed; extrapolation is not permitted. Consult McQuay for performance outside the cataloged ratings.
5. For LWT below 5.0°C please refer to Application Considerations.

Table 18, AGZ 070B - AGZ 130B

AGZ Unit Size	Fan & Control Power	LWT (°C)	Ambient Air Temperature (°C)														
			25			30			35			40			45		
			Unit kW	PWR kW _i	Unit COP	Unit kW	PWR kW _i	Unit COP	Unit kW	PWR kW _i	Unit COP	Unit kW	PWR kW _i	Unit COP	Unit kW	PWR kW _i	Unit COP
070B	7.3	5.0	238.4	68.0	3.51	228.7	73.8	3.10	218.4	80.4	2.72	207.6	87.7	2.37	196.0	95.8	2.05
		6.0	246.1	68.6	3.59	236.1	74.5	3.17	225.6	81.1	2.78	214.5	88.5	2.43	202.7	96.7	2.10
		7.0	254.0	69.3	3.67	243.8	75.2	3.24	233.0	81.8	2.85	221.6	89.3	2.48	209.5	97.5	2.15
		8.0	262.1	69.9	3.75	251.5	75.9	3.32	240.5	82.6	2.91	228.8	90.1	2.54	216.4	98.4	2.20
		9.0	270.3	70.6	3.83	259.5	76.6	3.39	248.2	83.4	2.98	236.2	90.9	2.60	223.5	99.3	2.26
		10.0	278.7	71.3	3.92	267.6	77.4	3.46	256.0	84.2	3.04	243.7	91.8	2.66	230.7	100.2	2.31
075B	10.9	5.0	266.3	76.0	3.51	256.7	82.0	3.13	246.6	88.8	2.78	235.7	96.5	2.45	223.9	105.2	2.13
		6.0	274.2	76.6	3.59	264.4	82.6	3.20	254.1	89.4	2.84	243.0	97.1	2.50	231.0	105.9	2.19
		7.0	282.2	77.2	3.66	272.3	83.2	3.27	261.7	90.0	2.91	250.5	97.8	2.56	238.3	106.6	2.24
		8.0	290.4	77.7	3.74	280.2	83.8	3.35	269.5	90.7	2.97	258.0	98.5	2.62	245.7	107.3	2.29
		9.0	298.8	78.3	3.82	288.4	84.5	3.42	277.5	91.3	3.04	265.8	99.2	2.68	253.2	108.1	2.35
		10.0	307.2	78.9	3.90	296.6	85.1	3.49	285.5	92.0	3.10	273.6	99.9	2.74	260.9	108.8	2.40
085B	10.9	5.0	288.1	82.0	3.52	277.6	88.5	3.14	266.6	95.8	2.78	255.1	104.0	2.45	243.0	113.2	2.15
		6.0	296.4	82.6	3.60	285.8	89.1	3.21	274.6	96.5	2.85	262.9	104.8	2.51	250.6	114.0	2.20
		7.0	305.0	83.2	3.67	294.1	89.8	3.28	282.8	97.2	2.91	270.8	105.5	2.57	258.3	114.9	2.25
		8.0	313.6	83.9	3.75	302.6	90.5	3.35	291.0	97.9	2.97	278.8	106.3	2.63	266.1	115.7	2.30
		9.0	322.4	84.5	3.82	311.2	91.2	3.42	299.4	98.6	3.04	287.0	107.1	2.68	274.1	116.6	2.36
		10.0	331.3	85.2	3.89	319.9	91.9	3.49	308.0	99.4	3.10	295.3	107.9	2.74	282.2	117.4	2.41
090B	10.9	5.0	309.8	87.8	3.53	298.5	94.8	3.15	286.7	102.7	2.79	274.5	111.4	2.47	262.1	121.0	2.17
		6.0	318.7	88.4	3.61	307.2	95.5	3.22	295.1	103.4	2.85	282.7	112.2	2.52	270.1	122.0	2.22
		7.0	327.7	89.1	3.68	316.0	96.2	3.29	303.8	104.2	2.91	291.1	113.1	2.58	278.2	122.9	2.27
		8.0	336.8	89.9	3.75	324.9	97.0	3.35	312.5	104.9	2.98	299.6	113.9	2.63	286.5	123.9	2.32
		9.0	346.1	90.6	3.83	334.0	97.7	3.42	321.4	105.7	3.04	308.3	114.8	2.69	294.9	124.9	2.37
		10.0	355.4	91.3	3.90	343.2	98.5	3.49	330.4	106.5	3.10	317.1	115.7	2.74	303.5	125.8	2.42
100B	14.5	5.0	353.8	100.8	3.52	340.1	109.1	3.12	325.7	118.5	2.75	310.3	129.1	2.41	294.0	140.8	2.09
		6.0	365.0	101.5	3.60	351.0	109.9	3.20	336.2	119.3	2.82	320.5	130.0	2.47	303.8	141.8	2.15
		7.0	376.4	102.3	3.69	362.1	110.7	3.27	347.0	120.2	2.89	330.9	130.9	2.53	313.9	142.8	2.20
		8.0	388.1	103.0	3.77	373.4	111.5	3.35	358.0	121.0	2.96	341.5	131.8	2.59	324.1	143.8	2.26
		9.0	399.9	103.8	3.86	384.9	112.4	3.43	369.2	121.9	3.03	352.4	132.8	2.66	334.5	144.8	2.32
		10.0	412.1	104.6	3.94	396.7	113.2	3.51	380.6	122.8	3.10	363.4	133.7	2.72	345.2	145.9	2.37
110B	14.5	5.0	389.6	113.0	3.45	374.6	122.1	3.07	358.7	132.4	2.71	341.5	144.2	2.37	323.1	157.5	2.06
		6.0	401.8	113.9	3.53	386.5	123.2	3.14	370.3	133.5	2.77	352.8	145.4	2.43	334.0	158.7	2.11
		7.0	414.3	114.9	3.61	398.6	124.2	3.21	382.1	134.6	2.84	364.2	146.5	2.49	345.1	160.0	2.16
		8.0	427.1	116.0	3.69	411.0	125.3	3.28	394.1	135.8	2.90	375.9	147.8	2.55	356.4	161.3	2.22
		9.0	440.2	117.0	3.77	423.7	126.4	3.36	406.4	136.9	2.97	387.9	149.0	2.61	368.0	162.6	2.27
		10.0	453.5	118.0	3.85	436.6	127.5	3.43	419.0	138.1	3.03	400.1	150.3	2.67	379.8	164.0	2.32
120B	14.5	5.0	435.1	126.0	3.46	417.8	136.2	3.07	399.7	147.6	2.71	380.9	160.4	2.38	361.4	174.7	2.07
		6.0	448.9	127.2	3.54	431.1	137.5	3.14	412.7	148.9	2.77	393.4	161.9	2.43	373.5	176.3	2.12
		7.0	462.9	128.4	3.61	444.8	138.7	3.21	425.9	150.3	2.83	406.2	163.3	2.49	385.8	177.9	2.17
		8.0	477.3	129.6	3.69	458.7	140.0	3.28	439.4	151.6	2.90	419.3	164.8	2.55	398.4	179.5	2.22
		9.0	492.0	130.9	3.77	473.0	141.3	3.35	453.2	153.0	2.96	432.6	166.3	2.60	411.3	181.2	2.28
		10.0	507.0	132.2	3.84	487.5	142.7	3.42	467.3	154.5	3.03	446.3	167.9	2.66	424.5	182.9	2.33
130B	14.5	5.0	470.6	135.8	3.47	451.5	146.8	3.08	431.9	159.0	2.72	412.1	172.6	2.39	392.2	187.6	2.09
		6.0	485.3	137.1	3.55	465.9	148.1	3.15	445.8	160.5	2.78	425.5	174.2	2.44	405.1	189.4	2.14
		7.0	500.4	138.4	3.62	480.5	149.5	3.22	460.0	162.0	2.84	439.2	175.9	2.50	418.2	191.3	2.19
		8.0	515.8	139.8	3.70	495.5	151.0	3.29	474.5	163.5	2.90	453.2	177.6	2.55	431.7	193.1	2.24
		9.0	531.4	141.2	3.77	510.7	152.4	3.35	489.3	165.0	2.96	467.4	179.3	2.61	445.4	195.1	2.29
		10.0	547.4	142.6	3.84	526.2	153.9	3.42	504.4	166.6	3.03	482.0	181.0	2.67	459.5	197.0	2.34

NOTES:

1. Ratings in accordance with ARI Standard 550/590-98.
2. Ratings based on HCFC-22, evaporator fouling factor of 0.0176, 5.6°C evaporator delta-T, and sea level altitude.
3. KW input is for the entire unit including compressors, fan motors and control power.
4. Interpolation is allowed; extrapolation is not permitted. Consult McQuay for performance outside the cataloged ratings.
5. For LWT below 5.0°C please refer to Application Considerations.

Part Load Data

Table 19, Part Load Data, AGZ 010A – AGZ 130B

AGZ Unit Size	% Load	Capacity Tons	Power kW _i	EER	IPLV	AGZ Unit Size	% Load	Capacity Tons	Power kW _i	EER	IPLV
010	100.0	9.8	12.1	9.7	12.2	050	100.0	47.0	56.6	10.0	14.1
	75.0	7.3	7.4	11.9			75.0	35.2	32.3	13.1	
	50.0	4.9	4.6	12.6			50.0	23.5	19.0	14.8	
	25.0	2.4	2.4	12.0			25.0	11.7	9.3	15.1	
013	100.0	13.3	16.7	9.6	12.5	055	100.0	52.2	63.6	9.9	14.1
	75.0	10.0	10.0	11.9			75.0	39.2	35.9	13.1	
	50.0	6.6	6.1	13.1			50.0	26.1	21.2	14.8	
	25.0	3.3	3.2	12.4			25.0	13.1	10.2	15.3	
017	100.0	15.9	19.8	9.6	12.8	060	100.0	57.1	70.5	9.7	14.5
	75.0	11.9	11.9	12.1			75.0	42.8	39.1	13.1	
	50.0	7.9	7.1	13.5			50.0	28.6	22.4	15.3	
	25.0	4.0	3.7	12.8			25.0	14.3	10.5	16.4	
020	100.0	20.4	25.4	9.6	12.5	065	100.0	61.4	75.5	9.8	14.1
	75.0	15.3	15.8	11.6			75.0	46.1	43.2	12.8	
	50.0	10.2	9.2	13.3			50.0	30.7	24.5	15.1	
	25.0	5.1	4.9	12.5			25.0	15.4	11.7	15.8	
025	100.0	22.7	28.3	9.6	12.9	070	100.0	65.5	81.6	9.6	14.0
	75.0	17.0	16.6	12.3			75.0	49.2	46.9	12.6	
	50.0	11.3	10.0	13.6			50.0	32.8	26.6	14.8	
	25.0	5.7	5.3	12.9			25.0	16.4	12.2	16.1	
029	100.0	28.3	34.2	9.9	13.3	075	100.0	73.7	89.7	9.9	14.0
	75.0	21.2	19.7	12.9			75.0	55.3	51.4	12.9	
	50.0	14.1	11.6	14.6			50.0	36.8	30.0	14.7	
	25.0	7.1	6.1	13.8			25.0	18.4	14.5	15.2	
034	100.0	34.0	42.5	9.6	13.9	085	100.0	79.6	96.9	9.9	14.1
	75.0	25.5	23.3	13.1			75.0	59.7	54.7	13.1	
	50.0	17.0	13.9	14.7			50.0	39.8	32.5	14.7	
	25.0	8.5	7.3	14.0			25.0	19.9	15.4	15.5	
026	100.0	27.2	33.4	9.8	13.6	090	100.0	85.5	103.9	9.9	13.9
	75.0	20.4	19.4	12.6			75.0	64.2	59.6	12.9	
	50.0	13.6	11.3	14.4			50.0	42.8	35.1	14.6	
	25.0	6.8	5.6	14.5			25.0	21.4	16.8	15.3	
030	100.0	30.2	37.3	9.7	13.6	100	100.0	97.6	119.9	9.8	13.8
	75.0	22.6	21.4	12.7			75.0	73.2	73.2	12.0	
	50.0	15.1	12.7	14.3			50.0	48.8	38.3	15.3	
	25.0	7.5	6.1	14.7			25.0	24.4	20.3	14.4	
035	100.0	33.2	41.1	9.7	14.1	110	100.0	107.5	134.3	9.6	13.4
	75.0	24.9	23.1	13.0			75.0	80.6	80.6	12.0	
	50.0	16.6	13.4	14.9			50.0	53.8	44.8	14.4	
	25.0	8.3	6.5	15.4			25.0	26.9	22.2	14.5	
040	100.0	38.5	46.4	9.9	14.5	120	100.0	119.8	149.8	9.6	13.4
	75.0	28.9	25.7	13.5			75.0	89.9	89.2	12.1	
	50.0	19.2	15.1	15.3			50.0	59.9	49.9	14.4	
	25.0	9.6	7.6	15.2			25.0	30.0	24.9	14.4	
045	100.0	42.5	51.7	9.9	14.5	130	100.0	129.4	161.4	9.6	13.4
	75.0	31.9	29.0	13.2			75.0	97.1	97.1	12.0	
	50.0	21.2	16.7	15.3			50.0	64.7	53.9	14.4	
	25.0	10.6	8.1	15.8			25.0	32.4	26.7	14.5	

NOTE: Certified according to ARI Standard 550/590-98.

Sound Data

Table 20, AGZ 010A-130B Sound Pressure w/o Sound Insulation

AGZ Unit Model	Number of Comp.	Number of Fans	Octave Band at Center Frequency								Overall A-Weighted
			63	125	250	500	1000	2000	4000	8000	
010A	2	2	52	52	52	54	48	46	44	42	55
013A	2	2	53	54	54	55	48	47	45	42	56
017A	2	2	58	56	55	53	52	50	48	48	57
020A	2	3	58	57	56	54	52	50	48	48	58
025A	2	3	58	58	56	55	52	50	48	48	58
029A	2	3	59	59	61	58	54	53	51	50	61
034A	2	3	61	62	63	59	55	54	53	51	63
026B	4	4	65	64	61	60	56	51	46	41	61
030B	4	4	65	64	61	60	56	51	46	41	61
035B	4	4	65	64	62	60	56	51	46	41	61
040B	4	4	65	64	63	61	57	52	47	42	62
045B	4	4	66	65	64	62	58	52	47	42	63
050B	4	4	66	66	64	62	58	52	47	42	63
055B	4	4	66	66	66	62	59	54	49	44	64
060B	4	4	67	66	67	62	59	54	49	44	64
065B	4	4	68	67	67	62	60	54	49	44	65
070B	4	4	68	68	67	62	60	54	49	44	65
075B	4	6	68	68	68	62	60	54	49	44	65
085B	4	6	67	65	65	64	62	56	54	54	66
090B	4	6	67	66	66	64	62	56	54	54	66
100B	6	6	66	68	65	65	62	56	56	55	67
110B	6	6	66	69	66	65	62	56	56	55	67
120B	6	6	67	68	66	65	62	58	59	56	68
130B	6	6	67	69	67	65	62	59	59	56	68

Note: Data at:

1. 30 feet (9m) from side of unit.
2. Q=2, unit on a flat roof or ground with no adjacent wall.
3. Octave band readings are flat dB, overall is "A" weighted.

Table 21, AGZ 010A-130B Sound Power w/o Sound insulation

AGZ Unit Model	Number of Comp.	Number of Fans	Octave Band at Center Frequency (per ARI Standard 370)								Overall A-Weighted
			63	125	250	500	1000	2000	4000	8000	
010A	2	2	79	79	79	81	75	73	71	69	82
013A	2	2	80	81	81	82	75	74	72	69	83
017A	2	2	85	83	82	80	79	77	75	75	84
020A	2	3	85	84	83	81	79	77	75	75	85
025A	2	3	85	85	83	82	79	77	75	75	85
029A	2	3	86	86	88	85	81	80	78	77	88
034A	2	3	88	89	90	86	82	81	80	78	90
026B	4	4	92	91	88	87	83	78	73	68	88
030B	4	4	92	91	88	87	83	78	73	68	88
035B	4	4	92	91	89	87	83	78	73	68	88
040B	4	4	92	91	90	88	84	79	74	69	89
045B	4	4	93	92	91	89	85	79	74	69	90
050B	4	4	93	93	91	89	85	79	74	69	90
055B	4	4	93	93	93	89	86	81	76	71	91
060B	4	4	94	93	94	89	86	81	76	71	91
065B	4	4	95	94	94	89	87	81	76	71	92
070B	4	4	95	95	94	89	87	81	76	71	92
075B	4	6	95	95	95	89	87	81	76	71	92
085B	4	6	94	92	92	91	89	83	81	81	93
090B	4	6	94	93	93	91	89	83	81	81	93
100B	6	8	93	95	92	92	89	83	83	82	94
110B	6	8	93	96	93	92	89	83	83	82	94
120B	6	8	94	95	93	92	89	85	86	83	95
130B	6	8	94	96	94	92	89	86	86	83	95

Note: 1. Octave band readings are flat dB, overall is "A" weighted.

Table 22, AGZ 010A-130B Sound Pressure w/ Sound Insulation

AGZ Unit Model	Number of Comp.	Number of Fans	Octave Band at Center Frequency								Overall A-Weighted
			63	125	250	500	1000	2000	4000	8000	
010A	2	2	52	52	51	52	46	45	43	41	53
013A	2	2	52	53	51	53	47	45	43	41	54
017A	2	2	52	53	53	54	47	45	44	42	55
020A	2	3	43	54	54	55	48	46	45	43	56
025A	2	3	54	54	54	55	48	46	45	43	56
029A	2	3	54	54	55	56	49	47	46	43	57
034A	2	3	55	55	56	57	50	48	47	43	58
026B	4	4	57	57	57	59	52	49	48	44	59
030B	4	4	57	57	56	57	50	48	47	43	58
035B	4	4	57	57	56	57	50	48	47	43	58
040B	4	4	57	57	56	57	50	48	47	43	58
045B	4	4	58	58	58	59	53	50	48	43	60
050B	4	4	58	58	58	59	53	50	48	43	60
055B	4	4	58	58	58	59	53	50	48	43	60
060B	4	4	58	58	58	59	53	50	48	43	60
065B	4	4	59	58	58	59	53	50	48	43	60
070B	4	4	61	58	58	59	53	50	48	43	60
075B	4	6	61	58	59	59	54	54	50	43	61
085B	4	6	61	59	59	59	56	53	50	44	61
090B	4	6	61	59	59	59	56	53	50	44	61
100B	6	6	63	59	59	59	56	53	50	44	61
110B	6	6	63	59	59	59	56	53	50	44	61
120B	6	6	63	59	60	59	56	53	50	44	61
130B	6	6	63	59	60	60	57	53	50	44	62

Note: Data at:

1. 30 feet (9m) from side of unit.
2. Q=2, unit on a flat roof or ground with no adjacent wall.
3. Octave band readings are flat dB, overall is "A" weighted.

Table 23, AGZ 010A-130B Sound Power w/ Sound insulation

AGZ Unit Model	Number of Comp.	Number of Fans	Octave Band at Center Frequency (per ARI Standard 370)								Overall A-Weighted
			63	125	250	500	1000	2000	4000	8000	
010A	2	2	79	79	78	79	73	72	70	68	80
013A	2	2	79	80	78	80	74	72	70	68	81
017A	2	2	79	80	80	81	74	72	71	69	82
020A	2	3	80	81	81	82	75	73	72	70	83
025A	2	3	81	81	81	82	75	73	72	70	83
029A	2	3	81	81	82	83	76	74	73	70	84
034A	2	3	82	82	83	84	77	75	74	70	85
026B	4	4	84	84	84	86	79	76	75	71	86
030B	4	4	84	84	83	84	77	75	74	70	85
035B	4	4	84	84	83	84	77	75	74	70	85
040B	4	4	84	84	83	84	77	75	74	70	85
045B	4	4	85	85	85	86	80	77	75	70	87
050B	4	4	85	85	85	86	80	77	75	70	87
055B	4	4	85	85	85	86	80	77	75	70	87
060B	4	4	85	85	85	86	80	77	75	70	87
065B	4	4	86	85	85	86	80	77	75	70	87
070B	4	4	88	85	85	86	80	77	75	70	87
075B	4	6	88	85	86	86	81	81	77	70	88
085B	4	6	88	86	86	86	83	80	77	71	88
090B	4	6	88	86	86	86	83	80	77	71	88
100B	6	8	90	86	86	86	83	80	77	71	88
110B	6	8	90	86	86	86	83	80	77	71	88
120B	6	8	90	86	87	86	83	80	77	71	88
130B	6	8	90	86	87	87	84	80	77	71	88

Note: 1. Octave band readings are flat dB, overall is "A" weighted.

Sound levels can be as important as unit cost and efficiency, and must be addressed before the start of any development program. Efforts by McQuay design engineers to design chillers that are sensitive to the sound requirements of the market, combined with inherently quiet scroll compressors, have paid off.

Background Information

Sound is a vibration in an elastic medium and is essentially a pressure and particle displacement phenomena. A vibrating body produces compression waves and, as the waves are emitted from the vibrating body, molecules are compressed. These values are transmitted through gas, liquid, solid-anything that is elastic or viscous.

The sound data provided in this section is presented with both sound pressure and sound power levels. Sound power is the total sound energy radiated by a source per unit of time integrated over the surface through which the sound is radiated. Sound power is a calculated quantity and cannot be measured directly like sound pressure. Sound power is not dependent on the surrounding environment or distance from the source, as is sound pressure.

Sound pressure varies with the distance from the source and is dependent on its surroundings. For example, a brick wall located 10 feet from a unit will affect the sound pressure measurements differently than a brick wall at 20 feet. Sound pressure is measured in decibels (dB), which is a dimensionless ratio (on a logarithmic scale) between measured sound pressure and a reference sound pressure level.

Sound Pressure Levels - Full Load

All sound pressure tables give the overall "A" weighted sound pressure levels which are considered typical of what can be measured in a free field with a hand held sound meter, in the absence of any nearby reflective surfaces. The sound pressure levels are measured at 30 feet (10 meters) from the side of the unit at 100% unit load and ARI conditions. 95°F (35°C) ambient air temperature and 54/44°F (12/7°C) evaporator water temperatures for air-cooled units.

Sound Power Levels

Acoustical consultants can require sound power octave band data to perform a detailed acoustical analysis. The tables present sound power levels per ARI Standard 370, "Sound Rating of Large Outdoor Refrigerating and Air Conditioning Equipment". These standards were developed to establish uniform methods of determining the sound power radiated by large outdoor and indoor equipment. The aforementioned methods are based on providing sound power levels by octave band and the overall 'A' weighted value. Measurements are taken over a prescribed area around the unit and the data is mathematically calculated to give the sound power, dB. Sound power can be thought of as basic sound level emanating from the unit without consideration of distance or obstructions.

Sound Reduction due to Distance from the Unit

The distance between a source of sound and the location of the sound measurement plays an important role in minimizing sound problems. The equation below can be used to calculate the sound pressure level at any distance if the sound power is known. Results for typical distances are tabulated in Table 24, dB Conversion of Sound Power to Pressure for Distance. Another way of determining the effect of distance is to work from sound pressure only. "Q", the directionality factor, is a dimensionless number that compensates for the type of sound reflection from the source. For example, a unit sitting on a flat roof or ground with no other reflective surfaces or attenuation due to grass, snow, etc., between source and receiver: $Q=2$.

Figure 7, "Q" Definition, Plan View, Unit Located in Center

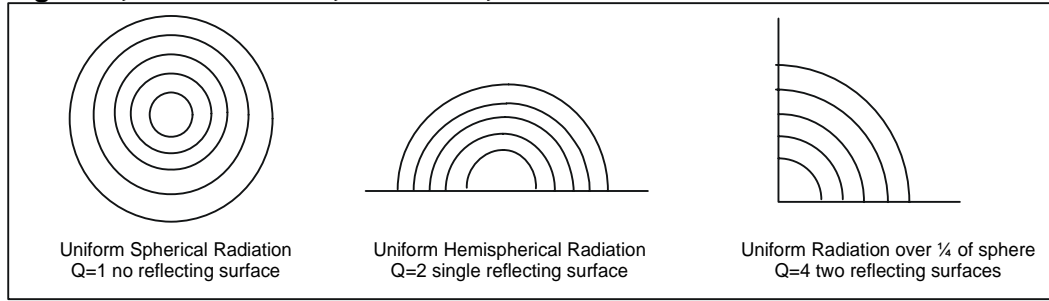

Sound pressure can be calculated at any distance from the unit if the sound power is known.

$$L_p = L_w - (20 \log r) + (10 \log Q) - .5$$

L_p = sound pressure

r = distance from unit in feet

L_w = sound power

Q = directionality factor

With $Q=1$, Unit suspended in space (theoretical condition), the equation simplifies to:

$$L_p = L_w - (20)(\log r) - 0.5$$

With $Q=2$, for a unit sitting on a flat roof or ground with no adjacent vertical wall as a reflective surface, the equation simplifies to:

$$L_p = L_w - (20)(\log r) + 2.5$$

With $Q=4$ for a unit sitting on a flat roof or ground with one adjacent vertical wall as a reflective surface, the equation simplifies to:

$$L_p = L_w - (20)(\log r) + 5.5$$

The equations are reduced to table form in Table 24 for various distances and the two most usual cases of "Q" type of location.

Table 24, dB Conversion of Sound Power to Pressure for Distance

Distance from Sound Source ft. (m)	DB Reduction from Sound Power at the Source to Sound Pressure at Referenced Distance	
	Q=2	Q=4
30 (9)	27.1	24.0
50 (15)	31.6	28.5
75 (23)	35.1	32.0
100 (30)	37.6	34.5
150 (46)	41.1	38.0
200 (61)	43.6	40.5
300 (91)	47.6	44.0

Figure 8, Sound Pressure Attenuation Due to Distance from Unit

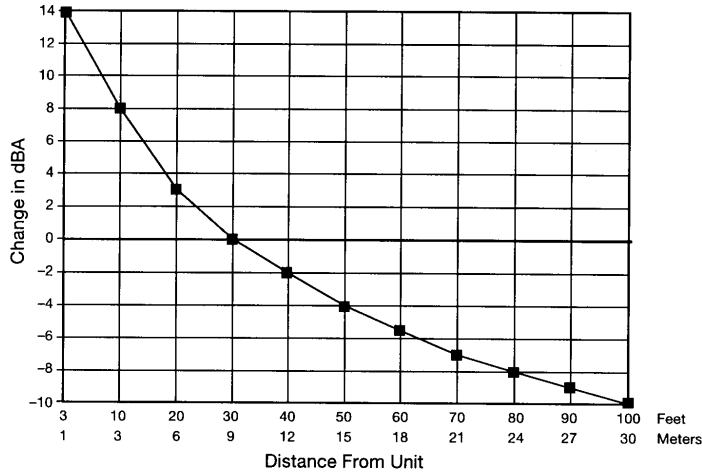

Sound Pressure Levels - Low Ambient Operation

Unit operation at a lower ambient temperature than 95°F (35°C) will also result in lower sound pressure levels. The sound pressure level will decrease 1 dBA for ambient temperatures between 85°F and 94°F (29.4°C and 34.4°C), 2 dBA for ambient temperatures between 75°F and 84°F (23.9°C and 28.9°C), and 3 dBA for ambient temperatures between 65°F and 74°F (18.3°C and 23.3°C).



Pressure Drop Curves

Figure 9, AGZ 010 – 130, Evaporator Pressure Drops

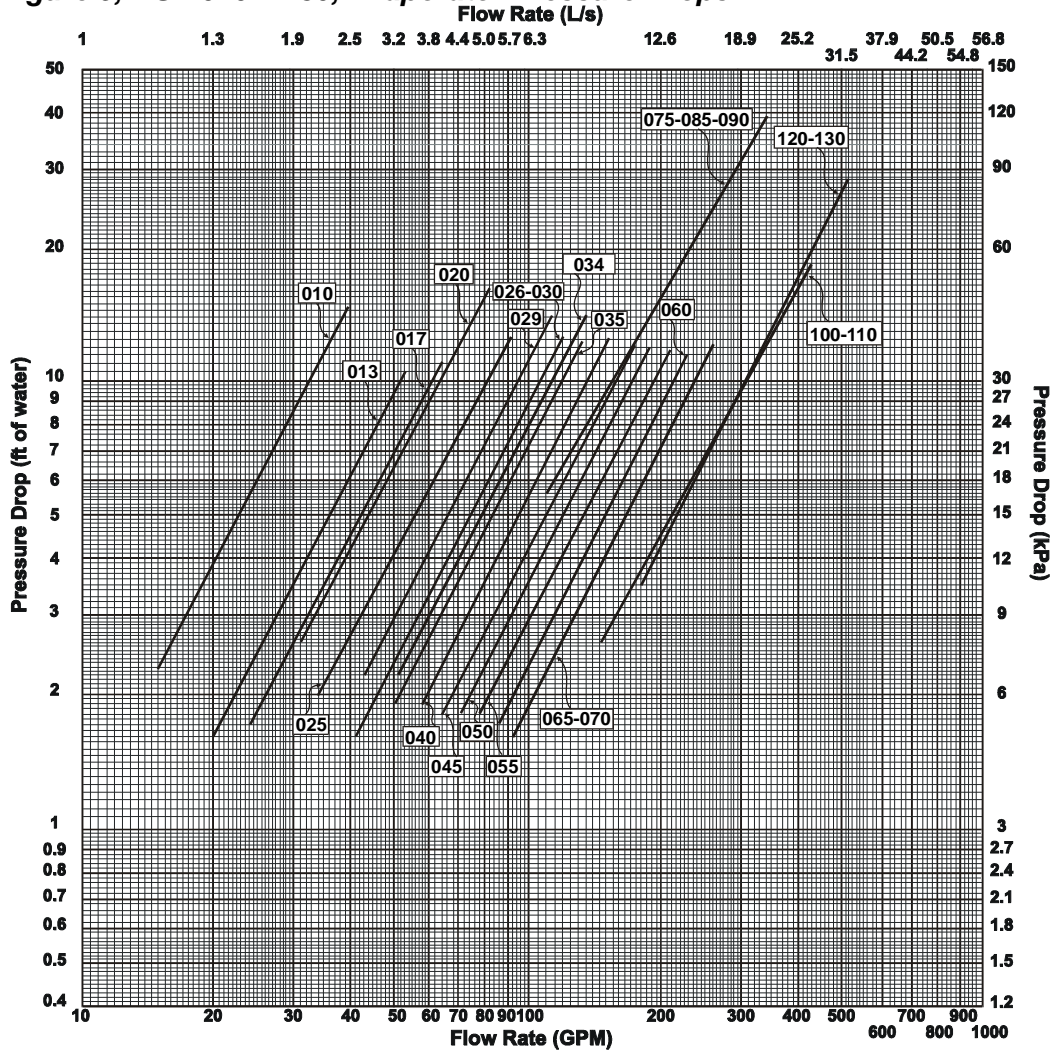

AGZ Unit Model	Minimum				Nominal				Maximum			
	Inch-Pound		S.I.		Inch-Pound		S.I.		Inch-Pound		S.I.	
	gpm	DP ft.	lps	DP kpa	gpm	DP ft.	lps	DP kpa	gpm	DP ft.	lps	DP kpa
AGZ 010A	15	2.3	0.9	6.9	24	5.7	1.5	17.0	39	14.8	2.5	44.1
AGZ 013A	20	1.6	1.3	4.8	32	4.0	2.0	11.9	53	10.5	3.3	31.3
AGZ 017A	24	1.7	1.5	5.1	38	4.3	2.4	12.8	64	11.2	4.0	33.4
AGZ 020A	31	2.6	1.9	7.7	49	6.2	3.1	18.5	82	16.3	5.2	48.6
AGZ 025A	34	2.0	2.2	6.0	55	4.8	3.5	14.3	91	12.7	5.7	37.8
AGZ 029A	43	2.2	2.7	6.6	68	5.3	4.3	15.8	113	14.1	7.1	42.0
AGZ 034A	51	2.2	3.2	6.6	82	5.3	5.2	15.8	136	14.2	8.6	42.3
AGZ 026B	41	1.6	2.6	4.7	65	3.9	4.1	11.6	109	10.4	6.9	30.9
AGZ 030B	45	1.9	2.9	5.7	72	4.7	4.6	14.1	121	12.7	7.6	37.8
AGZ 035B	50	1.9	3.1	5.6	80	4.6	5.0	13.8	133	12.4	8.4	36.9
AGZ 040B	58	1.9	3.6	5.7	92	4.7	5.8	14.0	154	12.6	9.7	37.5
AGZ 045B	64	1.8	4.0	5.4	102	4.5	6.4	13.4	170	12.1	10.7	35.9
AGZ 050B	71	1.8	4.4	5.4	113	4.5	7.1	13.3	188	12.0	11.9	35.7
AGZ 055B	78	1.8	4.9	5.3	125	4.4	7.9	13.0	209	11.7	13.2	34.8
AGZ 060B	86	1.7	5.4	5.2	137	4.3	8.6	12.8	228	11.5	14.4	34.2
AGZ 065B	92	1.6	5.8	4.9	147	4.1	9.3	12.1	246	10.9	15.5	32.5
AGZ 070B	98	1.9	6.2	5.6	157	4.6	9.9	13.7	262	12.3	16.5	36.8
AGZ 075B	111	5.6	7.0	16.5	177	12.5	11.2	37.4	295	30.4	18.6	90.7
AGZ 085B	119	6.4	7.5	18.9	191	14.3	12.1	42.7	318	34.8	20.1	103.6
AGZ 090B	128	7.2	8.1	21.4	205	16.2	12.9	48.4	342	39.4	21.6	117.3
AGZ 100B	146	2.6	9.2	7.7	234	6.1	14.8	18.2	390	15.5	24.6	46.2
AGZ 110B	161	3.1	10.2	9.2	258	7.3	16.3	21.7	430	18.5	27.1	55.1
AGZ 120B	180	3.5	11.3	10.4	288	8.9	18.1	26.5	479	24.6	30.2	73.4
AGZ 130B	194	4.1	12.2	12.1	311	10.4	19.6	30.9	518	28.7	32.7	85.6

Electrical Data

Standard/High Ambient Panels

Models AGZ-B (26 to 130 tons, two circuit) have electrical data and subsequent field wiring requirements that are tailored to individual applications.

There are many installations where the expected summer ambient air temperatures will be at 105°F (40.1°C) or less, resulting in smaller unit electrical requirements compared to operation at 106°F (41.1°C) and above. In these lower temperature cases, there can be considerable installation cost savings by using smaller and more appropriate electrical service.

Therefore, the AGZ electrical data is divided into two classifications based on the ambient environment temperature where the unit will operate. Standard Ambient unit electrical data (BS and BM models) is for operation in ambient temperatures of 105°F (40.1°C) or less. Units with the high ambient operation (BH and BB models) option are for use in 105°F (40.1°C) to 125°F (51.7°C).

The AGZ-B units for high ambient operation require the addition of the High Ambient Control Panel Option, which includes the addition of a small fan with a filter in the air intake to cool the control panel, and a unit nameplate that lists the larger electrical requirements.

All units with the optional VFD low ambient fan control automatically include the High Ambient Control Panel Option. Operation of the VFD generates a quantity of panel heat best removed by use of a control panel fan.

Winter Operation	0°F to 34°F		35°F and Above	
Fan Control	Optional VFD (1)		Standard FanTrol (2)	
Design Ambient Air Temperature	≤105°F	>106°F	≤105°F	>106°F
Electrical Data (3)	Standard Ambient	High Ambient	Standard Ambient	High Ambient
Panel Fan Required (4)	Yes	Yes	No	Yes
Model Designator (5)				
Packaged	BS	BH	BS	BH
Remote Evaporator	BM	BB	BM	BB

Notes:

- VFD is variable speed, fan control through the MicroTech II controller.
- FanTrol is fan cycling off discharge pressure.
- Standard ambient electrical data begins on page 39, high ambient data begins on page 53.
- The VFD option automatically includes the factory-installed panel fan and filter set.
- The designator is the last two characters in the model number, i.e. AGZ 100BS.

Panel Ratings

Voltage	Standard		Options	
	Standard Panel	With Optional VFD	High Short Circuit Rated Enclosure (kAIC)	High Interrupt Disconnect Switch (kAIC)
208-230	35	5	120	120
240	35	5	100	100
380-460	35	5	65	65
575	5	5	25	25

The high short circuit rated enclosure includes a high interrupt disconnect switch.

Notes for “Electrical Data Single- and Multi-Point” Power:

1. Unit wire size ampacity (MCA) is equal to 125% of the largest compressor-motor RLA plus 100% of RLA of all other loads in the circuit including the control transformer.
2. The control transformer is furnished, and no separate 115V power is required. For both single- and multi-point power connections, the control transformer is in circuit #1 with control power wired from there to circuit #2. In multi-point power, disconnecting power to circuit will disconnect all control power to the unit.
3. If a separate 115V power supply is used for the control circuit, then the wire sizing amps is 10 amps for all unit sizes.
4. Recommended power lead wire sizes for 3 conductors per conduit are based on 100% conductor ampacity in accordance with NEC. Voltage drop has not been included. Therefore, it is recommended that power leads be kept short. All terminal block connections must be made with copper (type THW) wire.
5. “Recommended Fuse Sizes” are selected at approximately 150% to 175% of the largest compressor RLA, plus 100% of all other loads in the circuit.
6. “Maximum Fuse or HACR breaker size” is selected at approximately 225% of the largest compressor RLA, plus 100% of all other loads in the circuit.
7. The recommended power lead wire sizes are based on an ambient temperature of 86°F (30°C). Ampacity correction factors must be applied for other ambient temperatures. Refer to the National Electrical Code Handbook.
8. Must be electrically grounded according to national and local electrical codes.

Voltage Limitations:

Within ± 10 percent of nameplate rating.

Notes for “Compressor and Condenser Fan Amp Draw”:

1. Compressor RLA values are for wiring sizing purposes only but do not reflect normal operating current draw at rated capacity.

Notes for “Field Wiring Data”

1. Requires a single disconnect to supply electrical power to the unit. This power supply must either be fused or use an HACR type circuit breaker.
2. All field wiring to unit power block or optional non-fused disconnect switch must be copper.
3. All field wire size values given in table apply to 75°C rated wire per NEC.

Circuit Breakers (AGZ 026 to 130 only)

Factory installed circuit breakers are standard on units with single point power supply only. This option provides unit installed compressor short circuit protection and makes servicing easier.

Connection Type	Power Block	Disconnect Swt.	Circuit Breakers	High Short Circuit Current
Single Point (Standard)	Std	Opt.	Std	Opt
Multi-Point (Optional)	Std	Opt.	Not Avail.	Opt.

Table 25, AGZ 010A – 034A, Electrical Data, Single Point

AGZ Unit Size	Volts	Minimum Circuit Ampacity (MCA)	Power Supply				Max. Fuse Or HACR Breaker Size	
			Field Wire		Hub		Recommended	Maximum
			Quantity	Wire Gauge 75C	Quantity	Nominal Size In. (mm)		
010A	208	54	3	6	1	1.00 (25)	60	70
	230	54	3	6	1	1.00 (25)	60	70
	460	26	3	10	1	1.00 (25)	30	35
	575	23	3	10	1	1.00 (25)	25	30
013A	208	65	3	6	1	1.00 (25)	80	80
	230	65	3	6	1	1.00 (25)	80	80
	460	34	3	10	1	1.00 (25)	40	45
	575	27	3	10	1	1.00 (25)	30	35
017A	208	79	3	4	1	1.00 (25)	90	100
	230	79	3	4	1	1.00 (25)	90	100
	460	41	3	8	1	1.00 (25)	45	50
	575	33	3	10	1	1.00 (25)	40	40
020A	208	103	3	2	1	1.25 (32)	125	125
	230	103	3	2	1	1.25 (32)	125	125
	460	53	3	6	1	1.00 (25)	60	70
	575	45	3	8	1	1.00 (25)	50	60
025A	208	110	3	2	1	1.25 (32)	125	150
	230	110	3	2	1	1.25 (32)	125	150
	460	58	3	6	1	1.00 (25)	70	80
	575	48	3	8	1	1.00 (25)	60	60
029A	208	127	3	1	1	1.50 (38)	150	175
	230	127	3	1	1	1.50 (38)	150	175
	460	62	3	6	1	1.00 (25)	70	80
	575	58	3	6	1	1.00 (25)	70	70
034A	208	182	3	3/0	1	1.50 (38)	225	250
	230	182	3	3/0	1	1.50 (38)	225	250
	460	79	3	4	1	1.00 (25)	90	100
	575	63	3	6	1	1.00 (25)	80	80

NOTE: See page 39 for all Electrical Data notes.

Table 26, AGZ 010 - 034A, Compressor and Fan Motor Amps, Single Point

AGZ Unit Size	Volts	Hz.	Rated Load Amps			No. of Fan Mtrs	Locked Rotor Amps			
			Compressors		Fan Motor (Each)		Fan Motor (Each)	Compressors		
			No. 1	No. 2				Across-The-Line		
								No. 1	No. 2	
010A	208	60	18.6	18.6	5.8	2	23.7	156	156	
	230		18.6	18.6	5.8	2	21.4	156	156	
	460		9.1	9.1	2.8	2	10.7	75	75	
	575		7.4	7.4	2.5	2	11.0	54	54	
013A	208	60	23.7	23.7	5.8	2	23.7	189	189	
	230		23.7	23.7	5.8	2	21.4	189	189	
	460		12.5	12.5	2.8	2	10.7	99	99	
	575		9.1	9.1	2.5	2	11.0	74	74	
017A	208	60	29.9	29.9	5.8	2	23.7	232	232	
	230		29.9	29.9	5.8	2	21.4	232	232	
	460		15.3	15.3	2.8	2	10.7	125	125	
	575		11.6	11.6	2.5	2	11.0	100	100	
020A	208	60	33.6	41.0	5.8	3	23.7	278	350	
	230		33.6	41.0	5.8	3	21.4	278	350	
	460		16.5	21.8	2.8	3	10.7	127	158	
	575		13.7	17.3	2.5	3	11.0	100	125	
025A	208	60	41.0	41.0	5.8	3	23.7	350	350	
	230		41.0	41.0	5.8	3	21.4	350	350	
	460		21.8	21.8	2.8	3	10.7	158	158	
	575		17.3	17.3	2.5	3	11.0	125	125	
029A	208	60	48.5	48.5	5.8	3	23.7	425	425	
	230		48.5	48.5	5.8	3	21.4	425	425	
	460		23.7	23.7	2.8	3	10.7	187	187	
	575		21.7	21.7	2.5	3	11.0	148	148	
034A	208	60	73.1	73.1	5.8	3	23.7	505	505	
	230		73.1	73.1	5.8	3	21.4	505	505	
	460		31.0	31.0	2.8	3	10.7	225	225	
	575		24.4	24.4	2.5	3	11.0	180	180	

NOTE: See page 39 for all Electrical Data notes.

Table 27, AGZ 010A - 034A, Field Wiring Data, Single Point

AGZ UNIT SIZE	Volts	HZ.	Wiring to Standard Power Block Terminal		Wiring to Optional Disconnect Switch	
			Maximum Terminal Amps	Connector Wire Range (Copper Wire Only)	Disconnect Size	Connector Wire Range (Copper Wire Only)
010A	208	60	175	14 GA – 2/0	100	#8-1/0
	230		175	14 GA – 2/0	100	#8-1/0
	460		175	14 GA – 2/0	63	#1-#14
	575		175	14 GA – 2/0	63	#1-#14
013A	208	60	175	14 GA – 2/0	100	#8-1/0
	230		175	14 GA – 2/0	100	#8-1/0
	460		175	14 GA – 2/0	63	#1-#14
	575		175	14 GA – 2/0	63	#1-#14
017A	208	60	175	14 GA – 2/0	100	#10-1/0
	230		175	14 GA – 2/0	100	#10-1/0
	460		175	14 GA – 2/0	63	#1-#14
	575		175	14 GA – 2/0	63	#1-#14
020A	208	60	175	14 GA – 2/0	225	#2-4/0
	230		175	14 GA – 2/0	225	#2-4/0
	460		175	14 GA – 2/0	100	#8-1/0
	575		175	14 GA – 2/0	100	#10-1/0
025A	208	60	175	14 GA – 2/0	225	#2-4/0
	230		175	14 GA – 2/0	225	#2-4/0
	460		175	14 GA – 2/0	100	#8-1/0
	575		175	14 GA – 2/0	100	#10-1/0
029A	208	60	175	14 GA – 2/0	225	#2-4/0
	230		175	14 GA – 2/0	225	#2-4/0
	460		175	14 GA – 2/0	100	#8-1/0
	575		175	14 GA – 2/0	100	#10-1/0
034A	208	60	335	6 GA – 400 kcmil	225	#2-4/0
	230		335	6 GA – 400 kcmil	225	#2-4/0
	460		175	14 GA – 2/0	125	#3-3/0
	575		175	14 GA – 2/0	100	#10-1/0

NOTE: See page 39 for all Electrical Data notes.

Table 28, AGZ 026BM/BS – 070BM/BS, Electrical Data, Single Point (105°F & below)

AGZ Unit Size	Volts	Minimum Circuit Ampacity (MCA)	Power Supply Field Wire		Recomm'd. Fuse Or HACR Breaker Size	Max. Fuse Or HACR Breaker Size
			Quantity	Wire Gauge 75C		
026B	208	133	3	1/0	150	150
	230	126	3	#1	150	150
	380	80	3	#4	90	90
	460	68	3	#4	80	80
	575	52	3	#6	60	60
030B	208	146	3	1/0	175	175
	230	143	3	1/0	175	175
	380	88	3	#3	100	100
	460	74	3	#4	80	90
	575	58	3	#6	70	70
035B	208	158	3	2/0	175	175
	230	150	3	1/0	175	175
	380	96	3	#3	110	110
	460	79	3	#4	90	90
	575	64	3	#6	70	70
040B	208	167	3	2/0	200	200
	230	167	3	2/0	200	200
	380	113	3	#2	125	125
	460	81	3	#4	90	90
	575	70	3	#4	80	80
045B	208	184	3	3/0	225	225
	230	184	3	3/0	225	225
	380	121	3	#1	125	125
	460	94	3	#3	110	110
	575	78	3	#4	90	90
050B	208	199	3	3/0	225	225
	230	199	3	3/0	225	225
	380	127	3	#1	150	150
	460	104	3	#2	125	125
	575	86	3	#3	100	100
055B	208	221	3	4/0	250	250
	230	214	3	4/0	250	250
	380	145	3	1/0	175	175
	460	108	3	#2	125	125
	575	96	3	#3	110	110
060B	208	248	3	250	300	300
	230	228	3	4/0	250	250
	380	156	3	2/0	175	175
	460	112	3	#2	150	150
	575	105	3	#2	125	125
065B	208	281	3	300	350	350
	230	281	3	300	350	350
	380	162	3	2/0	200	200
	460	124	3	#1	150	150
	575	109	3	#2	125	125
070B	208	301	3	350	350	350
	230	301	3	350	350	350
	380	168	3	2/0	200	200
	460	130	3	#1	150	150
	575	112	3	#2	125	125

NOTES:

1. Units operating in ambient temperatures of 95°F (35°C) and above must use the Maximum Fuse or HACR Breaker size.
2. All Electrical Data notes are on page 39.
3. Conduit hubs are not provided.

**Table 29, AGZ 026BM/BS – 070BM/BS, Compressor and Fan Motor Amps, Single and Multi-Point
(Up to 105°F)**

AGZ Unit Size	Volts	Rated Load Amps							No. Of Fan Motors	Locked Rotor Amps						
		Compressors						F.L.Amps Fan Motors (Each)		Fan Motors (Each)	Compressors					
		No. 1	No. 3	No. 5	No. 2	No. 4	No. 6				Across-The-Line					
											No.1	No. 3	No. 5	No.2	No.4	No. 6
026B	208	25.7	25.7	-	25.7	25.7	-	5.8	4	23.3	189	189	-	189	189	-
	230	24.2	24.2	-	24.2	24.2	-	5.8	4	26.1	189	189	-	189	189	-
	380	14.9	14.9	-	14.9	14.9	-	4.1	4	20.0	112	112	-	112	112	-
	460	13.4	13.4	-	13.4	13.4	-	2.8	4	13.0	99	99	-	99	99	-
	575	9.3	9.3	-	9.3	9.3	-	3.0	4	14.0	74	74	-	74	74	-
030B	208	25.7	25.7	-	31.8	31.8	-	5.8	4	23.3	189	189	-	232	232	-
	230	24.2	24.2	-	31.8	31.8	-	5.8	4	26.1	189	189	-	232	232	-
	380	14.9	14.9	-	18.6	18.6	-	4.1	4	20.0	112	112	-	144	144	-
	460	13.4	13.4	-	16.0	16.0	-	2.8	4	13.0	99	99	-	125	125	-
	575	9.3	9.3	-	12.2	12.2	-	3.0	4	14.0	74	74	-	100	100	-
035B	208	31.8	31.8	-	31.8	31.8	-	5.8	4	23.3	232	232	-	232	232	-
	230	29.9	29.9	-	29.9	29.9	-	5.8	4	26.1	232	232	-	232	232	-
	380	18.6	18.6	-	18.6	18.6	-	4.1	4	20.0	144	144	-	144	144	-
	460	16.0	16.0	-	16.0	16.0	-	2.8	4	13.0	125	125	-	125	125	-
	575	12.2	12.2	-	12.2	12.2	-	3.0	4	14.0	100	100	-	100	100	-
040B	208	33.8	33.8	-	33.8	33.8	-	5.8	4	23.3	278	278	-	278	278	-
	230	33.8	33.8	-	33.8	33.8	-	5.8	4	26.1	278	278	-	278	278	-
	380	22.8	22.8	-	22.8	22.8	-	4.1	4	20.0	151	151	-	151	151	-
	460	16.5	16.5	-	16.5	16.5	-	2.8	4	13.0	127	127	-	127	127	-
	575	13.7	13.7	-	13.7	13.7	-	3.0	4	14.0	100	100	-	100	100	-
045B	208	33.8	33.8	-	41.4	41.4	-	5.8	4	23.3	278	278	-	350	350	-
	230	33.8	33.8	-	41.4	41.4	-	5.8	4	26.1	278	278	-	350	350	-
	380	22.8	22.8	-	26.0	26.0	-	4.1	4	20.0	151	151	-	195	195	-
	460	16.5	16.5	-	21.8	21.8	-	2.8	4	13.0	127	127	-	158	158	-
	575	13.7	13.7	-	17.3	17.3	-	3.0	4	14.0	100	100	-	125	125	-
050B	208	41.4	41.4	-	41.4	41.4	-	5.8	4	23.3	350	350	-	350	350	-
	230	41.4	41.4	-	41.4	41.4	-	5.8	4	26.1	350	350	-	350	350	-
	380	26.0	26.0	-	26.0	26.0	-	4.1	4	20.0	195	195	-	195	195	-
	460	21.8	21.8	-	21.8	21.8	-	2.8	4	13.0	158	158	-	158	158	-
	575	17.3	17.3	-	17.3	17.3	-	3.0	4	14.0	125	125	-	125	125	-
055B	208	41.0	41.0	-	51.3	51.3	-	5.8	4	23.3	350	350	-	425	425	-
	230	41.0	41.0	-	48.1	48.1	-	5.8	4	26.1	350	350	-	425	425	-
	380	26.0	26.0	-	33.8	33.8	-	4.1	4	20.0	195	195	-	239	239	-
	460	21.8	21.8	-	23.7	23.7	-	2.8	4	13.0	158	158	-	187	187	-
	575	17.3	17.3	-	21.8	21.8	-	3.0	4	14.0	125	125	-	148	148	-
060B	208	52.8	52.8	-	52.8	52.8	-	5.8	4	23.3	425	425	-	425	425	-
	230	48.1	48.1	-	48.1	48.1	-	5.8	4	26.1	425	425	-	425	425	-
	380	32.7	32.7	-	32.7	32.7	-	4.1	4	20.0	239	239	-	239	239	-
	460	23.7	23.7	-	23.7	23.7	-	2.8	4	13.0	187	187	-	187	187	-
	575	21.8	21.8	-	21.8	21.8	-	3.0	4	14.0	148	148	-	148	148	-
065B	208	52.8	52.8	-	52.8	73.1	-	7.8	4	31.7	425	425	-	425	505	-
	230	52.8	52.8	-	52.8	73.1	-	7.8	4	35.6	425	425	-	425	505	-
	380	32.7	32.7	-	32.7	38.2	-	4.1	4	20.0	239	239	-	239	280	-
	460	23.7	23.7	-	23.7	30.1	-	3.6	4	17.8	187	187	-	187	225	-
	575	21.8	21.8	-	21.8	25.2	-	3.0	4	14.0	148	148	-	148	180	-
070B	208	52.8	73.1	-	52.8	73.1	-	7.8	4	31.7	425	505	-	425	505	-
	230	52.8	73.1	-	52.8	73.1	-	7.8	4	35.6	425	505	-	425	505	-
	380	32.7	38.2	-	32.7	38.2	-	4.1	4	20.0	239	280	-	239	280	-
	460	23.7	30.1	-	23.7	30.1	-	3.6	4	17.8	187	225	-	187	225	-
	575	21.8	25.2	-	21.8	25.2	-	3.0	4	14.0	148	180	-	148	180	-

NOTE: All Electrical Data notes are on page 39.

Table 30, AGZ 026 BM/BS – 070BM/BS, Field Wiring, Single Point

AGZ Unit Size	Volts	Wiring to Standard Power Block		Wiring to Optional Non-Fused Disconnect Switch	
		Terminal Amps	Connector Wire Range (Copper Wire Only)	Disconnect Size	Connector Wire Range (Copper Wire Only)
026B	208	175	14 GA – 2/0	225	# 4 - 300 kcmil
	230	175	14 GA – 2/0	225	# 4 - 300 kcmil
	380	175	14 GA – 2/0	150	# 4 - 300 kcmil
	460	175	14 GA – 2/0	150	# 4 - 300 kcmil
	575	175	14 GA – 2/0	150	# 4 - 300 kcmil
030B	208	380	#4 – 500 kcmil	225	# 4 - 300 kcmil
	230	380	#4 – 500 kcmil	225	# 4 - 300 kcmil
	380	175	14 GA – 2/0	150	# 4 - 300 kcmil
	460	175	14 GA – 2/0	150	# 4 - 300 kcmil
	575	175	14 GA – 2/0	150	# 4 - 300 kcmil
035B	208	380	#4 – 500 kcmil	225	# 4 - 300 kcmil
	230	380	#4 – 500 kcmil	225	# 4 - 300 kcmil
	380	175	14 GA – 2/0	150	# 4 - 300 kcmil
	460	175	14 GA – 2/0	150	# 4 - 300 kcmil
	575	175	14 GA – 2/0	150	# 4 - 300 kcmil
040B	208	380	#4 – 500 kcmil	225	# 4 - 300 kcmil
	230	380	#4 – 500 kcmil	225	# 4 - 300 kcmil
	380	175	14 GA – 2/0	150	# 4 - 300 kcmil
	460	175	14 GA – 2/0	150	# 4 - 300 kcmil
	575	175	14 GA – 2/0	150	# 4 - 300 kcmil
045B	208	380	#4 – 500 kcmil	225	# 4 - 300 kcmil
	230	380	#4 – 500 kcmil	225	# 4 - 300 kcmil
	380	175	14 GA – 2/0	150	# 4 - 300 kcmil
	460	175	14 GA – 2/0	150	# 4 - 300 kcmil
	575	175	14 GA – 2/0	150	# 4 - 300 kcmil
050B	208	380	#4 – 500 kcmil	250	#6 - 350 kcmil
	230	380	#4 – 500 kcmil	250	#6 - 350 kcmil
	380	175	14 GA – 2/0	150	# 4 - 300 kcmil
	460	175	14 GA – 2/0	150	# 4 - 300 kcmil
	575	175	14 GA – 2/0	150	# 4 - 300 kcmil
055B	208	380	#4 – 500 kcmil	400	250 kcmil -500 kcmil
	230	380	#4 – 500 kcmil	400	250 kcmil -500 kcmil
	380	175	14 GA – 2/0	250	#6 - 350 kcmil
	460	175	14 GA – 2/0	150	# 4 - 300 kcmil
	575	175	14 GA – 2/0	150	# 4 - 300 kcmil
060B	208	380	#4 – 500 kcmil	400	250 kcmil -500 kcmil
	230	380	#4 – 500 kcmil	400	250 kcmil -500 kcmil
	380	380	#4 – 500 kcmil	250	#6 - 350 kcmil
	460	175	14 GA – 2/0	150	# 4 - 300 kcmil
	575	175	14 GA – 2/0	150	# 4 - 300 kcmil
065B	208	380	#4 – 500 kcmil	400	250 kcmil -500 kcmil
	230	380	#4 – 500 kcmil	400	250 kcmil -500 kcmil
	380	380	#4 – 500 kcmil	250	#6 - 350 kcmil
	460	175	14 GA – 2/0	250	# 4 - 300 kcmil
	575	175	14 GA – 2/0	150	# 4 - 300 kcmil
070B	208	380	#4 – 500 kcmil	400	250 kcmil -500 kcmil
	230	380	#4 – 500 kcmil	400	250 kcmil -500 kcmil
	380	380	#4 – 500 kcmil	250	#6 - 350 kcmil
	460	380	#4 – 500 kcmil	250	# 4 - 300 kcmil
	575	175	14 GA – 2/0	150	# 4 - 300 kcmil

NOTE: All Electrical Data notes are on page 39.

**Table 31, AGZ 075BM/BS – 130BM/BS, Electrical Wiring, Single Point
(Up to 105°F)**

AGZ Unit Size	Volts	Minimum Circuit Ampacity (MCA)	Power Supply		Recomm'd. Fuse Or HACR Breaker Size	Max. Fuse Or HACR Breaker Size
			Field Wire			
			Quantity	Wire Gauge 75C		
075B	208	358	6	4/0	400	400
	230	358	6	4/0	400	400
	380	187	3	3/0	225	225
	460	150	3	1/0	175	175
	575	125	3	#1	150	150
085B	208	380	6	250	450	450
	230	380	6	250	450	450
	380	219	3	250	250	250
	460	171	3	2/0	200	200
	575	136	3	1/0	150	150
090B	208	414	6	300	500	500
	230	414	6	300	500	500
	380	248	3	250	300	300
	460	188	3	3/0	225	225
	575	146	3	1/0	175	175
100B	208	463	6	350	500	500
	230	463	6	300	500	500
	380	260	3	300	300	300
	460	199	3	3/0	225	225
	575	171	3	2/0	175	175
110B	208	528	6 - (2)	300	600	600
	230	528	6 - (2)	300	600	600
	380	282	3	300	300	300
	460	220	3	4/0	250	250
	575	182	3	3/0	200	200
120B	208	613	6 - (2)	350	700	700
	230	613	6 - (2)	350	700	700
	380	323	3	400	350	350
	460	248	3	250	250	250
	575	198	3	3/0	225	225
130B	208	613	6 - (2)	350	700	700
	230	613	6 - (2)	350	700	700
	380	361	6	4/0	400	400
	460	273	3	300	300	300
	575	212	3	4/0	225	225

NOTES:

1. Units operating in ambient temperatures of 95°F (35°C) and above must use the Maximum Fuse or HACR Breaker size.
2. All Electrical Data notes are on page 39.
3. (2) indicates that two conduits are required.
4. Conduit hubs are not supplied.

Table 32, AGZ 075BM/BS – 130BM/BS, Compressor and Fan Motor Amps, Single and Multi-Point (Up to 105°F)

AGZ Unit Size	Volts	Rated Load Amps							No. Of Fan Motors	Locked Rotor Amps						
		Compressors						F.L. Amps Fan Motors (Each)		Fan Motors (Each)	Compressors					
		Across-The-Line									No.1	No. 3	No. 5	No.2	No.4	No. 6
		No. 1	No. 3	No. 5	No. 2	No. 4	No. 6									
075B	208	73.1	73.1	-	73.1	73.1	-	7.8	6	31.7	505	505	-	505	505	-
	230	73.1	73.1	-	73.1	73.1	-	7.8	6	35.6	505	505	-	505	505	-
	380	38.2	38.2	-	38.2	38.2	-	4.1	6	20.0	280	280	-	280	280	-
	460	30.1	30.1	-	30.1	30.1	-	3.6	6	17.8	225	225	-	225	225	-
	575	25.2	25.2	-	25.2	25.2	-	3.0	6	14.0	180	180	-	180	180	-
085B	208	73.1	73.1	-	83.3	83.3	-	7.8	6	31.7	505	505	-	500	500	-
	230	73.1	73.1	-	83.3	83.3	-	7.8	6	35.6	505	505	-	500	500	-
	380	38.2	38.2	-	52.5	52.5	-	4.1	6	20.0	280	280	-	305	305	-
	460	30.1	30.1	-	39.0	39.0	-	3.6	6	17.8	225	225	-	250	250	-
	575	25.2	25.2	-	30.0	30.0	-	3.0	6	14.0	180	180	-	198	198	-
090B	208	86.4	86.4	-	86.4	86.4	-	7.8	6	31.7	500	500	-	500	500	-
	230	86.4	86.4	-	86.4	86.4	-	7.8	6	35.6	500	500	-	500	500	-
	380	52.5	52.5	-	52.5	52.5	-	4.1	6	20.0	305	305	-	305	305	-
	460	39.0	39.0	-	39.0	39.0	-	3.6	6	17.8	250	250	-	250	250	-
	575	30.0	30.0	-	30.0	30.0	-	3.0	6	14.0	198	198	-	198	198	-
100B	208	52.8	52.8	52.8	74.5	74.5	74.5	7.8	8	31.7	425	425	425	505	505	505
	230	52.8	52.8	52.8	74.5	74.5	74.5	7.8	8	35.6	425	425	425	505	505	505
	380	32.7	32.7	32.7	39.8	39.8	39.8	4.1	8	20.0	239	239	239	280	280	280
	460	23.7	23.7	23.7	30.6	30.6	30.6	3.6	8	17.8	187	187	187	225	225	225
	575	21.8	21.8	21.8	25.2	25.2	25.2	3.0	8	14.0	148	148	148	180	180	180
110B	208	74.5	74.5	74.5	74.5	74.5	74.5	7.8	8	31.7	505	505	505	505	505	505
	230	74.5	74.5	74.5	74.5	74.5	74.5	7.8	8	35.6	505	505	505	505	505	505
	380	39.8	39.8	39.8	39.8	39.8	39.8	4.1	8	20.0	280	280	280	280	280	280
	460	30.6	30.6	30.6	30.6	30.6	30.6	3.6	8	17.8	225	225	225	225	225	225
	575	25.2	25.2	25.2	25.2	25.2	25.2	3.0	8	14.0	180	180	180	180	180	180
120B	208	87.9	87.9	87.9	88.0	88.0	88.0	7.8	8	31.7	505	505	505	500	500	500
	230	87.9	87.9	87.9	88.0	88.0	88.0	7.8	8	35.6	505	505	505	500	500	500
	380	39.8	39.8	39.8	52.5	52.5	52.5	4.1	8	20.0	280	280	280	305	305	305
	460	30.6	30.6	30.6	39.0	39.0	39.0	3.6	8	17.8	225	225	225	250	250	250
	575	25.2	25.2	25.2	30.0	30.0	30.0	3.0	8	14.0	180	180	180	198	198	198
130B	208	88.0	88.0	88.0	88.0	88.0	88.0	7.8	8	31.7	500	500	500	500	500	500
	230	88.0	88.0	88.0	88.0	88.0	88.0	7.8	8	35.6	500	500	500	500	500	500
	380	52.5	52.5	52.5	52.5	52.5	52.5	4.1	8	20.0	305	305	305	305	305	305
	460	39.0	39.0	39.0	39.0	39.0	39.0	3.6	8	17.8	250	250	250	250	250	250
	575	30.0	30.0	30.0	30.0	30.0	30.0	3.0	8	14.0	198	198	198	198	198	198

NOTE: All Electrical Data notes are on page 39.

Table 33, AGZ 075BM/BS - 130BM/BS, Field Wiring, Single Point

AGZ Unit Size	Volts	Wiring to Standard Power Block		Wiring to Optional Non-Fused Disconnect Switch	
		Terminal Amps	Connector Wire Range (Copper Wire Only)	Disconnect Size	Connector Wire Range (Copper Wire Only)
075B	208	760	2 GA – 500 kcmil	600	(2) 250 kcmil -500 kcmil
	230	760	2 GA – 500 kcmil	600	(2) 250 kcmil -500 kcmil
	380	380	#4 – 500 kcmil	250	#6 - 350 kcmil
	460	380	#4 – 500 kcmil	250	#6 - 350 kcmil
	575	380	#4 – 500 kcmil	250	#6 - 350 kcmil
085B	208	760	2 GA – 500 kcmil	600	(2) 250 kcmil -500 kcmil
	230	760	2 GA – 500 kcmil	600	(2) 250 kcmil -500 kcmil
	380	380	#4 – 500 kcmil	400	250 kcmil -500 kcmil
	460	380	#4 – 500 kcmil	250	#6 - 350 kcmil
	575	380	#4 – 500 kcmil	250	#6 - 350 kcmil
090B	208	760	2 GA – 500 kcmil	600	(2) 250 kcmil -500 kcmil
	230	760	2 GA – 500 kcmil	600	(2) 250 kcmil -500 kcmil
	380	380	#4 – 500 kcmil	400	250 kcmil -500 kcmil
	460	380	#4 – 500 kcmil	250	#6 - 350 kcmil
	575	380	#4 – 500 kcmil	250	#6 - 350 kcmil
100B	208	760	2 GA – 500 kcmil	600	(2) 250 kcmil -500 kcmil
	230	760	2 GA – 500 kcmil	600	(2) 250 kcmil -500 kcmil
	380	380	#4 – 500 kcmil	400	250 kcmil -500 kcmil
	460	380	#4 – 500 kcmil	400	250 kcmil -500 kcmil
	575	380	#4 – 500 kcmil	250	#6 - 350 kcmil
110B	208	760	2 GA – 500 kcmil	800	(2) 250 kcmil -500 kcmil
	230	760	2 GA – 500 kcmil	800	(2) 250 kcmil -500 kcmil
	380	380	#4 – 500 kcmil	400	250 kcmil -500 kcmil
	460	380	#4 – 500 kcmil	400	(2) 3/0-250 kcmil
	575	380	#4 – 500 kcmil	400	(2) 3/0-250 kcmil
120B	208	760	2 GA – 500 kcmil	800	(2) 250 kcmil -500 kcmil
	230	760	2 GA – 500 kcmil	800	(2) 250 kcmil -500 kcmil
	380	380	#4 – 500 kcmil	400	250 kcmil -500 kcmil
	460	380	#4 – 500 kcmil	400	250 kcmil -500 kcmil
	575	380	#4 – 500 kcmil	400	(2) 3/0-250 kcmil
130B	208	760	2 GA – 500 kcmil	800	(2) 250 kcmil -500 kcmil
	230	760	2 GA – 500 kcmil	800	(2) 250 kcmil -500 kcmil
	380	760	2 GA – 500 kcmil	600	(2) 3/0-250 kcmil
	460	380	#4 – 500 kcmil	400	250 kcmil -500 kcmil
	575	380	#4 – 500 kcmil	400	(2) 3/0-250 kcmil

NOTE: All Electrical Data notes are on page 39.

Table 34, AGZ 026BM/BS – 070BM/BS, Electrical Data, Multi-Point (Up to 105°F)

AGZ Unit Size	Volts	Electrical Circuit #1					Electrical Circuit #2				
		Minimum Circuit Ampacity (MCA)	Power Supply Field Wire		Recomm'd Fuse or HACR Breaker Size	Max. Fuse or HACR Breaker Size	Minimum Circuit Ampacity (MCA)	Power Supply Field Wire		Recomm'd Fuse or HACR Breaker Size	Max. Fuse or HACR Breaker Size
			Qty	Wire Gauge				Qty	Wire Gauge		
026B	208	70	3	#4	80	90	70	3	#4	80	90
	230	66	3	#4	80	90	66	3	#4	80	90
	380	42	3	#8	50	50	42	3	#8	50	50
	460	36	3	#8	45	45	36	3	#8	45	45
	575	27	3	#10	35	35	27	3	#10	35	35
030B	208	70	3	#4	80	90	83	3	#4	100	110
	230	66	3	#4	80	90	83	3	#4	100	100
	380	42	3	#8	50	50	50	3	#8	60	60
	460	36	3	#8	45	45	42	3	#8	50	50
	575	27	3	#10	35	35	34	3	#10	40	45
035B	208	83	3	#4	100	110	83	3	#4	100	110
	230	79	3	#4	100	100	79	3	#4	100	100
	380	50	3	#8	60	60	50	3	#8	60	60
	460	42	3	#8	50	50	42	3	#8	50	50
	575	34	3	#10	40	45	34	3	#10	40	45
040B	208	88	3	#3	110	110	88	3	#3	110	110
	230	88	3	#3	110	100	88	3	#3	110	100
	380	60	3	#6	70	80	60	3	#6	70	80
	460	43	3	#8	50	50	43	3	#8	50	50
	575	37	3	#8	45	50	37	3	#8	45	50
045B	208	88	3	#3	110	110	105	3	#2	125	125
	230	88	3	#3	110	110	105	3	#2	125	125
	380	60	3	#6	70	80	67	3	#4	80	80
	460	43	3	#8	50	50	55	3	#6	70	70
	575	37	3	#8	45	50	45	3	#8	50	60
050B	208	105	3	#2	125	125	105	3	#2	125	125
	230	105	3	#2	125	125	105	3	#2	125	125
	380	67	3	#4	80	80	67	3	#4	80	80
	460	55	3	#6	70	70	55	3	#6	70	70
	575	45	3	#8	50	60	45	3	#8	50	60
055B	208	105	3	#2	125	125	120	3	#1	150	150
	230	105	3	#2	125	125	120	3	#1	150	150
	380	67	3	#4	80	80	82	3	#3	100	110
	460	55	3	#6	70	70	59	3	#6	70	80
	575	45	3	#8	50	60	55	3	#6	70	70
060B	208	120	3	#1	150	150	120	3	#1	150	150
	230	120	3	#1	150	150	120	3	#1	150	150
	380	82	3	#3	100	110	82	3	#3	100	110
	460	59	3	#6	70	80	59	3	#6	70	80
	575	55	3	#6	70	70	55	3	#6	70	70
065B	208	135	3	1/0	175	175	160	3	2/0	200	225
	230	135	3	1/0	175	175	160	3	2/0	200	225
	380	82	3	#4	100	110	89	3	#3	110	125
	460	61	3	#6	70	80	69	3	#4	90	100
	575	55	3	#6	70	70	59	3	#6	70	80
070B	208	160	3	2/0	200	225	160	3	2/0	200	225
	230	160	3	2/0	200	225	160	3	2/0	200	225
	380	89	3	#3	110	125	89	3	#3	110	125
	460	69	3	#4	90	100	69	3	#4	90	100
	575	59	3	#6	70	80	59	3	#6	70	80

NOTES:

1. All Electrical Data notes are on page 39.
2. Conduit hubs are not supplied.

Table 35, AGZ 026BM/BS - 070BM/BS, Field Wiring, Multi-Point

AGZ Unit Size	Volts	Wiring to Standard Power Block				Wiring to Optional Non-Fused Disconnect Switch			
		Terminal Amps		Connector Wire Range (Copper Wire Only)		Disconnect Size		Connector Wire Range (Copper Wire Only)	
		Cir #1	Cir #2	Cir #1	Cir #2	Cir #1	Cir #2	Cir #1	Cir #2
026B	208	175	175	14 GA - 2/0	14 GA - 2/0	150	150	#14 - 1/0	#14 - 1/0
	230	175	175	14 GA - 2/0	14 GA - 2/0	150	150	#14 - 1/0	#14 - 1/0
	380	175	175	14 GA - 2/0	14 GA - 2/0	150	150	#14 - 1/0	#14 - 1/0
	460	175	175	14 GA - 2/0	14 GA - 2/0	150	150	#14 - 1/0	#14 - 1/0
	575	175	175	14 GA - 2/0	14 GA - 2/0	150	150	#14 - 1/0	#14 - 1/0
030B	208	175	175	14 GA - 2/0	14 GA - 2/0	150	150	#14 - 1/0	#14 - 1/0
	230	175	175	14 GA - 2/0	14 GA - 2/0	150	150	#14 - 1/0	#14 - 1/0
	380	175	175	14 GA - 2/0	14 GA - 2/0	150	150	#14 - 1/0	#14 - 1/0
	460	175	175	14 GA - 2/0	14 GA - 2/0	150	150	#14 - 1/0	#14 - 1/0
	575	175	175	14 GA - 2/0	14 GA - 2/0	150	150	#14 - 1/0	#14 - 1/0
035B	208	175	175	14 GA - 2/0	14 GA - 2/0	150	150	#14 - 1/0	#14 - 1/0
	230	175	175	14 GA - 2/0	14 GA - 2/0	150	150	#14 - 1/0	#14 - 1/0
	380	175	175	14 GA - 2/0	14 GA - 2/0	150	150	#14 - 1/0	#14 - 1/0
	460	175	175	14 GA - 2/0	14 GA - 2/0	150	150	#14 - 1/0	#14 - 1/0
	575	175	175	14 GA - 2/0	14 GA - 2/0	150	150	#14 - 1/0	#14 - 1/0
040B	208	175	175	14 GA - 2/0	14 GA - 2/0	150	150	#14 - 1/0	#14 - 1/0
	230	175	175	14 GA - 2/0	14 GA - 2/0	150	150	#14 - 1/0	#14 - 1/0
	380	175	175	14 GA - 2/0	14 GA - 2/0	150	150	#14 - 1/0	#14 - 1/0
	460	175	175	14 GA - 2/0	14 GA - 2/0	150	150	#14 - 1/0	#14 - 1/0
	575	175	175	14 GA - 2/0	14 GA - 2/0	150	150	#14 - 1/0	#14 - 1/0
045B	208	175	175	14 GA - 2/0	14 GA - 2/0	150	150	#14 - 1/0	#14 - 1/0
	230	175	175	14 GA - 2/0	14 GA - 2/0	150	150	#14 - 1/0	#14 - 1/0
	380	175	175	14 GA - 2/0	14 GA - 2/0	150	150	#14 - 1/0	#14 - 1/0
	460	175	175	14 GA - 2/0	14 GA - 2/0	150	150	#14 - 1/0	#14 - 1/0
	575	175	175	14 GA - 2/0	14 GA - 2/0	150	150	#14 - 1/0	#14 - 1/0
050B	208	175	175	14 GA - 2/0	14 GA - 2/0	150	150	#14 - 1/0	#14 - 1/0
	230	175	175	14 GA - 2/0	14 GA - 2/0	150	150	#14 - 1/0	#14 - 1/0
	380	175	175	14 GA - 2/0	14 GA - 2/0	150	150	#14 - 1/0	#14 - 1/0
	460	175	175	14 GA - 2/0	14 GA - 2/0	150	150	#14 - 1/0	#14 - 1/0
	575	175	175	14 GA - 2/0	14 GA - 2/0	150	150	#14 - 1/0	#14 - 1/0
055B	208	175	175	14 GA - 2/0	14 GA - 2/0	150	150	#14 - 1/0	#14 - 1/0
	230	175	175	14 GA - 2/0	14 GA - 2/0	150	150	#14 - 1/0	#14 - 1/0
	380	175	175	14 GA - 2/0	14 GA - 2/0	150	150	#14 - 1/0	#14 - 1/0
	460	175	175	14 GA - 2/0	14 GA - 2/0	150	150	#14 - 1/0	#14 - 1/0
	575	175	175	14 GA - 2/0	14 GA - 2/0	150	150	#14 - 1/0	#14 - 1/0
060B	208	175	175	14 GA - 2/0	14 GA - 2/0	150	150	#14 - 1/0	#14 - 1/0
	230	175	175	14 GA - 2/0	14 GA - 2/0	150	150	#14 - 1/0	#14 - 1/0
	380	175	175	14 GA - 2/0	14 GA - 2/0	150	150	#14 - 1/0	#14 - 1/0
	460	175	175	14 GA - 2/0	14 GA - 2/0	150	150	#14 - 1/0	#14 - 1/0
	575	175	175	14 GA - 2/0	14 GA - 2/0	150	150	#14 - 1/0	#14 - 1/0
065B	208	380	380	#4 - 500 kcmil	#4 - 500 kcmil	225	225	#4 - 300 kcmil	#4 - 300 kcmil
	230	380	380	#4 - 500 kcmil	#4 - 500 kcmil	225	225	#4 - 300 kcmil	#4 - 300 kcmil
	380	175	175	14 GA - 2/0	14 GA - 2/0	150	150	#14 - 1/0	#14 - 1/0
	460	175	175	14 GA - 2/0	14 GA - 2/0	150	150	#14 - 1/0	#14 - 1/0
	575	175	175	14 GA - 2/0	14 GA - 2/0	150	150	#14 - 1/0	#14 - 1/0
070B	208	380	380	#4 - 500 kcmil	#4 - 500 kcmil	225	225	#4 - 300 kcmil	#4 - 300 kcmil
	230	380	380	#4 - 500 kcmil	#4 - 500 kcmil	225	225	#4 - 300 kcmil	#4 - 300 kcmil
	380	175	175	14 GA - 2/0	14 GA - 2/0	150	150	#14 - 1/0	#14 - 1/0
	460	175	175	14 GA - 2/0	14 GA - 2/0	150	150	#14 - 1/0	#14 - 1/0
	575	175	175	14 GA - 2/0	14 GA - 2/0	150	150	#14 - 1/0	#14 - 1/0

NOTE: All Electrical Data notes are on page 39.

Table 36, AGZ 075BM/BS - 130BM/BS, Field Wiring Data

AGZ Unit Size	Volts	Wiring to Standard Power Block				Wiring to Optional Non-Fused Disconnect Switch			
		Terminal Amps		Connector Wire Range (Copper Wire Only)		Disconnect Size		Connector Wire Range (Copper Wire Only)	
		Cir #1	Cir #2	Cir #1	Cir #2	Cir #1	Cir #2	Cir #1	Cir #2
075B	208	380	380	#4 – 500 kcmil	#4 – 500 kcmil	250	250	#4 – 300 kcmil	#4 – 300 kcmil
	230	380	380	#4 – 500 kcmil	#4 – 500 kcmil	250	250	#4 – 300 kcmil	#4 – 300 kcmil
	380	175	175	14 GA – 2/0	14 GA – 2/0	250	250	#4 – 300 kcmil	#4 – 300 kcmil
	460	175	175	14 GA – 2/0	14 GA – 2/0	150	150	#14 - 1/0	#14 - 1/0
	575	175	175	14 GA – 2/0	14 GA – 2/0	150	150	#14 - 1/0	#14 - 1/0
085B	208	380	380	#4 – 500 kcmil	#4 – 500 kcmil	250	250	#4 – 300 kcmil	#4 – 300 kcmil
	230	380	380	#4 – 500 kcmil	#4 – 500 kcmil	250	250	#4 – 300 kcmil	#4 – 300 kcmil
	380	175	175	14 GA – 2/0	14 GA – 2/0	250	250	#4 – 300 kcmil	#4 – 300 kcmil
	460	175	175	14 GA – 2/0	14 GA – 2/0	150	150	#14 - 1/0	#14 - 1/0
	575	175	175	14 GA – 2/0	14 GA – 2/0	150	150	#14 - 1/0	#14 - 1/0
090B	208	380	380	#4 – 500 kcmil	#4 – 500 kcmil	250	250	#4 – 300 kcmil	#4 – 300 kcmil
	230	380	380	#4 – 500 kcmil	#4 – 500 kcmil	250	250	#4 – 300 kcmil	#4 – 300 kcmil
	380	175	175	14 GA – 2/0	14 GA – 2/0	250	250	#4 – 300 kcmil	#4 – 300 kcmil
	460	175	175	14 GA – 2/0	14 GA – 2/0	150	150	#14 - 1/0	#14 - 1/0
	575	175	175	14 GA – 2/0	14 GA – 2/0	150	150	#14 - 1/0	#14 - 1/0
100B	208	380	380	#4 – 500 kcmil	#4 – 500 kcmil	250	400	#4 – 300 kcmil	250 – 500 kcmil
	230	380	380	#4 – 500 kcmil	#4 – 500 kcmil	250	400	#4 – 300 kcmil	250 – 500 kcmil
	380	175	175	14 GA – 2/0	14 GA – 2/0	150	250	#14 - 1/0	#4 – 300 kcmil
	460	175	175	14 GA – 2/0	14 GA – 2/0	150	250	#14 - 1/0	#4 – 300 kcmil
	575	175	175	14 GA – 2/0	14 GA – 2/0	150	150	#14 - 1/0	#14 - 1/0
110B	208	380	380	#4 – 500 kcmil	#4 – 500 kcmil	400	400	250 – 500 kcmil	250 – 500 kcmil
	230	380	380	#4 – 500 kcmil	#4 – 500 kcmil	400	400	250 – 500 kcmil	250 – 500 kcmil
	380	380	380	#4 – 500 kcmil	#4 – 500 kcmil	250	250	#4 – 300 kcmil	#4 – 300 kcmil
	460	380	380	#4 – 500 kcmil	#4 – 500 kcmil	250	250	#4 – 300 kcmil	#4 – 300 kcmil
	575	175	175	14 GA – 2/0	14 GA – 2/0	150	150	#14 - 1/0	#14 - 1/0
120B	208	380	380	#4 – 500 kcmil	#4 – 500 kcmil	400	400	250 – 500 kcmil	250 – 500 kcmil
	230	380	380	#4 – 500 kcmil	#4 – 500 kcmil	400	400	250 – 500 kcmil	250 – 500 kcmil
	380	380	380	#4 – 500 kcmil	#4 – 500 kcmil	250	250	#4 – 300 kcmil	#4 – 300 kcmil
	460	380	380	#4 – 500 kcmil	#4 – 500 kcmil	250	250	#4 – 300 kcmil	#4 – 300 kcmil
	575	175	175	14 GA – 2/0	14 GA – 2/0	150	150	#14 - 1/0	#14 - 1/0
130B	208	380	380	#4 – 500 kcmil	#4 – 500 kcmil	400	400	250 – 500 kcmil	250 – 500 kcmil
	230	380	380	#4 – 500 kcmil	#4 – 500 kcmil	400	400	250 – 500 kcmil	250 – 500 kcmil
	380	380	380	#4 – 500 kcmil	#4 – 500 kcmil	250	250	#4 – 300 kcmil	#4 – 300 kcmil
	460	380	380	#4 – 500 kcmil	#4 – 500 kcmil	250	250	#4 – 300 kcmil	#4 – 300 kcmil
	575	175	175	14 GA – 2/0	14 GA – 2/0	150	150	#14 - 1/0	#14 - 1/0

NOTE: All Electrical Data notes are on page 39.

Table 37, AGZ 065BM/BS - 130BM/BS, Electrical Data, Multi-Point (Up to 105°F)

AGZ Unit Size	Volts	Electrical Circuit #1					Electrical Circuit #2				
		Minimum Circuit Ampacity (MCA)	Power Supply Field Wire		Recomm'd Fuse or HACR Breaker Size	Max. Fuse or HACR Breaker Size	Minimum Circuit Ampacity (MCA)	Power Supply Field Wire		Recomm'd Fuse or HACR Breaker Size	Max. Fuse or HACR Breaker Size
			Qty	Wire Gauge 75C				Qty	Wire Gauge 75C		
075B	208	188	3	3/0	225	250	188	3	3/0	225	250
	230	188	3	3/0	225	250	188	3	3/0	225	250
	380	98	3	#3	110	125	98	3	#3	110	125
	460	79	3	#4	90	110	79	3	#4	90	110
	575	66	3	#4	80	90	66	3	#4	80	90
085B	208	188	3	3/0	225	250	218	3	4/0	250	300
	230	188	3	3/0	225	250	218	3	4/0	250	250
	380	98	3	#3	110	125	130	3	#1	150	175
	460	79	3	#4	90	110	99	3	#3	125	125
	575	66	3	#4	80	90	77	3	#4	90	100
090B	208	218	3	4/0	250	300	218	3	4/0	250	300
	230	218	3	4/0	250	250	218	3	4/0	250	250
	380	130	3	#1	150	175	130	3	#1	150	175
	460	99	3	#3	125	125	99	3	#3	125	125
	575	77	3	#4	90	100	77	3	#4	90	100
100B	208	203	3	4/0	250	250	273	3	300	300	300
	230	203	3	3/0	225	225	273	3	300	300	300
	380	123	3	#1	150	150	146	3	1/0	175	200
	460	92	3	#3	110	110	114	3	#1	150	175
	575	83	3	#4	100	100	94	3	#3	110	125
110B	208	273	3	300	300	300	273	3	300	300	300
	230	273	3	300	300	300	273	3	300	300	300
	380	146	3	1/0	175	175	146	3	1/0	175	175
	460	114	3	#1	125	125	114	3	#1	125	125
	575	94	3	#3	110	110	94	3	#3	110	110
120B	208	317	3	300	400	400	317	3	400	400	400
	230	317	3	300	400	400	318	3	400	400	400
	380	146	3	1/0	175	175	187	3	2/0	225	225
	460	114	3	#1	125	125	141	3	1/0	175	175
	575	94	3	#3	110	110	110	3	#2	125	125
130B	208	317	3	400	400	400	317	3	400	400	400
	230	318	3	400	400	400	318	3	400	400	400
	380	187	3	2/0	225	225	187	3	2/0	225	225
	460	141	3	1/0	175	175	141	3	1/0	175	175
	575	110	3	#2	125	125	110	3	#2	125	125

NOTES:

1. All Electrical Data notes are on page 39.
2. Conduit hubs are not supplied.

High Ambient

Table 38, AGZ 026BB/BH – 070BB/BH, Electrical Data, Single Point

AGZ Unit Size	Volts	Minimum Circuit Ampacity (MCA)	Power Supply		Recomm'd. Fuse Or HACR Breaker Size	Max. Fuse Or HACR Breaker Size
			Field Wire			
			Quantity	Wire Gauge 75C		
026B	208	147	3	1/0	175	175
	230	133	3	1/0	150	150
	380	80	3	#4	90	90
	460	68	3	#4	80	80
	575	53	3	#6	60	60
030B	208	158	3	2/0	175	175
	230	144	3	1/0	175	175
	380	88	3	#3	100	100
	460	74	3	#4	90	90
	575	59	3	#6	70	70
035B	208	168	3	2/0	200	200
	230	155	3	2/0	175	175
	380	96	3	#3	110	110
	460	80	3	#4	90	90
	575	64	3	#6	70	70
040B	208	187	3	3/0	200	200
	230	167	3	2/0	200	200
	380	113	3	#2	125	125
	460	84	3	#4	90	90
	575	70	3	#4	80	80
045B	208	207	3	4/0	225	225
	230	188	3	3/0	225	225
	380	123	3	#1	125	125
	460	94	3	#3	110	110
	575	78	3	#4	90	90
050B	208	226	3	4/0	225	225
	230	207	3	3/0	225	225
	380	132	3	1/0	150	150
	460	104	3	#2	125	125
	575	86	3	#3	100	100
055B	208	249	3	250	250	250
	230	229	3	4/0	250	250
	380	147	3	1/0	175	175
	460	115	3	#2	125	125
	575	96	3	#3	110	110
060B	208	270	3	300	300	300
	230	248	3	250	250	250
	380	160	3	2/0	175	175
	460	124	3	#1	150	150
	575	105	3	#2	125	125
065B	208	303	3	350	350	350
	230	282	3	300	350	350
	380	164	3	2/0	200	200
	460	138	3	1/0	175	175
	575	115	3	#2	125	125
070B	208	323	3	400	400	400
	230	304	3	350	350	350
	380	172	3	2/0	200	200
	460	150	3	1/0	175	175
	575	123	3	#1	150	150

NOTES:

1. All Electrical Data notes are on page 39.
2. Conduit hubs are not provided.

Table 39, AGZ 026BB/BH – 070BB/BH, Compressor and Fan Motor Amps, Single and Multi-Point (106°F to 125°F)

AGZ Unit Size	Volts	Rated Load Amps							No. of Fan Motors	Locked Rotor Amps						
		Compressors						F.L.Amps Fan Motors (Each)		R.L.Amps Fan Motors (Each)	Compressors					
		No. 1	No. 3	No. 5	No. 2	No. 4	No. 6				Across-The-Line					
											No.1	No. 3	No. 5	No.2	No.4	No. 6
026B	208	29.0	29.0	-	29.0	29.0	-	5.8	4	23.3	189	189	-	189	189	-
	230	25.7	25.7	-	25.7	25.7	-	5.8	4	26.1	189	189	-	189	189	-
	380	14.9	14.9	-	14.9	14.9	-	4.1	4	20.0	112	112	-	112	112	-
	460	13.4	13.4	-	13.4	13.4	-	2.8	4	13.0	99	99	-	99	99	-
	575	9.5	9.5	-	9.5	9.5	-	3.0	4	14.0	74	74	-	74	74	-
030B	208	29.0	29.0	-	34.0	34.0	-	5.8	4	23.3	189	189	-	232	232	-
	230	25.7	25.7	-	30.9	30.9	-	5.8	4	26.1	189	189	-	232	232	-
	380	14.9	14.9	-	18.6	18.6	-	4.1	4	20.0	112	112	-	144	144	-
	460	13.4	13.4	-	16.2	16.2	-	2.8	4	13.0	99	99	-	125	125	-
	575	9.5	9.5	-	12.2	12.2	-	3.0	4	14.0	74	74	-	100	100	-
035B	208	34.0	34.0	-	34.0	34.0	-	5.8	4	23.3	232	232	-	232	232	-
	230	30.9	30.9	-	30.9	30.9	-	5.8	4	26.1	232	232	-	232	232	-
	380	18.6	18.6	-	18.6	18.6	-	4.1	4	20.0	144	144	-	144	144	-
	460	16.2	16.2	-	16.2	16.2	-	2.8	4	13.0	125	125	-	125	125	-
	575	12.2	12.2	-	12.2	12.2	-	3.0	4	14.0	100	100	-	100	100	-
040B	208	38.5	38.5	-	38.5	38.5	-	5.8	4	23.3	278	278	-	278	278	-
	230	33.8	33.8	-	33.8	33.8	-	5.8	4	26.1	278	278	-	278	278	-
	380	22.8	22.8	-	22.8	22.8	-	4.1	4	20.0	151	151	-	151	151	-
	460	17.0	17.0	-	17.0	17.0	-	2.8	4	13.0	127	127	-	127	127	-
	575	13.7	13.7	-	13.7	13.7	-	3.0	4	14.0	100	100	-	100	100	-
045B	208	38.5	38.5	-	47.6	47.6	-	5.8	4	23.3	278	278	-	350	350	-
	230	33.8	33.8	-	43.3	43.3	-	5.8	4	26.1	278	278	-	350	350	-
	380	22.8	22.8	-	27.2	27.2	-	4.1	4	20.0	151	151	-	195	195	-
	460	17.0	17.0	-	21.8	21.8	-	2.8	4	13.0	127	127	-	158	158	-
	575	13.7	13.7	-	17.3	17.3	-	3.0	4	14.0	100	100	-	125	125	-
050B	208	47.6	47.6	-	47.6	47.6	-	5.8	4	23.3	350	350	-	350	350	-
	230	43.3	43.3	-	43.3	43.3	-	5.8	4	26.1	350	350	-	350	350	-
	380	27.2	27.2	-	27.2	27.2	-	4.1	4	20.0	195	195	-	195	195	-
	460	21.8	21.8	-	21.8	21.8	-	2.8	4	13.0	158	158	-	158	158	-
	575	17.3	17.3	-	17.3	17.3	-	3.0	4	14.0	125	125	-	125	125	-
055B	208	47.6	47.6	-	58.1	58.1	-	5.8	4	23.3	350	350	-	425	425	-
	230	43.3	43.3	-	52.8	52.8	-	5.8	4	26.1	350	350	-	425	425	-
	380	27.2	27.2	-	33.8	33.8	-	4.1	4	20.0	195	195	-	239	239	-
	460	21.8	21.8	-	26.5	26.5	-	2.8	4	13.0	158	158	-	187	187	-
	575	17.3	17.3	-	21.8	21.8	-	3.0	4	14.0	125	125	-	148	148	-
060B	208	58.1	58.1	-	58.1	58.1	-	5.8	4	23.3	425	425	-	425	425	-
	230	52.8	52.8	-	52.8	52.8	-	5.8	4	26.1	425	425	-	425	425	-
	380	33.8	33.8	-	33.8	33.8	-	4.1	4	20.0	239	239	-	239	239	-
	460	26.5	26.5	-	26.5	26.5	-	2.8	4	13.0	187	187	-	187	187	-
	575	21.8	21.8	-	21.8	21.8	-	3.0	4	14.0	148	148	-	148	148	-
065B	208	58.1	58.1	-	58.1	78.0	-	7.8	4	31.7	425	425	-	425	505	-
	230	52.8	52.8	-	52.8	74.1	-	7.8	4	35.6	425	425	-	425	505	-
	380	32.7	32.7	-	32.7	39.8	-	4.1	4	20.0	239	239	-	239	280	-
	460	25.5	25.5	-	25.5	37.5	-	3.6	4	17.8	187	187	-	187	225	-
	575	21.8	21.8	-	21.8	29.9	-	3.0	4	14.0	148	148	-	148	180	-
070B	208	58.1	78.0	-	58.1	78.0	-	7.8	4	31.7	425	505	-	425	505	-
	230	52.8	74.1	-	52.8	74.1	-	7.8	4	35.6	425	505	-	425	505	-
	380	32.7	39.8	-	32.7	39.8	-	4.1	4	20.0	239	280	-	239	280	-
	460	25.5	37.5	-	25.5	37.5	-	3.6	4	17.8	187	225	-	187	225	-
	575	21.8	29.9	-	21.8	29.9	-	3.0	4	14.0	148	180	-	148	180	-

NOTE: All Electrical Data notes are on page 39.

**Table 40, AGZ 026BB/BH - 070BB/BH, Electrical Data, Multi-Point
(106°F to 125°F)**

AGZ Unit Size	Volts	Electrical Circuit #1				Electrical Circuit #2			
		Minimum Circuit Ampacity (MCA)	Power Supply Field Wire		Max. Fuse or HACR Breaker Size	Minimum Circuit Ampacity (MCA)	Power Supply Field Wire		Max. Fuse or HACR Breaker Size
			Qty	Wire Gauge 75C			Qty	Wire Gauge 75C	
026B	208	77	3	#4	100	77	3	#4	100
	230	70	3	#4	90	70	3	#4	90
	380	42	3	#8	50	40	3	#8	50
	460	36	3	#8	45	36	3	#8	45
	575	27	3	#10	35	27	3	#10	35
030B	208	77	3	#4	100	88	3	#3	110
	230	70	3	#4	90	81	3	#4	110
	380	42	3	#8	50	50	3	#8	60
	460	36	3	#8	45	42	3	#8	50
	575	27	3	#10	35	34	3	#10	45
035B	208	88	3	#3	110	88	3	#3	110
	230	81	3	#4	110	81	3	#4	110
	380	50	3	#8	60	50	3	#8	60
	460	42	3	#8	50	42	3	#8	50
	575	34	3	#10	45	34	3	#10	45
040B	208	98	3	#3	125	98	3	#3	125
	230	88	3	#3	110	88	3	#3	110
	380	60	3	#6	80	60	3	#6	80
	460	44	3	#8	60	44	3	#8	60
	575	37	3	#8	50	37	3	#8	50
045B	208	98	3	#3	125	119	3	#1	150
	230	88	3	#3	110	109	3	#2	150
	380	60	3	#6	80	70	3	#4	90
	460	44	3	#8	60	55	3	#6	70
	575	37	3	#8	50	45	3	#8	60
050B	208	119	3	#1	150	119	3	#1	150
	230	109	3	#2	150	109	3	#2	150
	380	70	3	#4	90	70	3	#4	90
	460	55	3	#6	70	55	3	#6	70
	575	45	3	#8	60	45	3	#8	60
055B	208	119	3	#1	150	142	3	1/0	200
	230	109	3	#2	150	130	3	#1	175
	380	70	3	#4	90	84	3	#4	110
	460	55	3	#6	70	65	3	#4	90
	575	45	3	#8	60	55	3	#6	70
060B	208	142	3	1/0	200	142	3	1/0	200
	230	130	3	#1	175	130	3	#1	175
	380	84	3	#4	110	84	3	#4	110
	460	65	3	#4	90	65	3	#4	90
	575	55	3	#6	70	55	3	#6	70
070B	208	146	3	1/0	200	171	3	2/0	225
	230	134	3	1/0	175	161	3	2/0	225
	380	82	3	#4	110	91	3	#3	125
	460	67	3	#6	90	80	3	#4	110
	575	55	3	#6	70	65	3	#6	90

NOTES:

1. All Electrical Data notes are on page 39.
2. Conduit hubs are not supplied.

**Table 41, AGZ 075BB/BH – 130BB/BH, Electrical Data, Single Point
(Above 105°F)**

AGZ Unit Size	Volts	Minimum Circuit Ampacity (MCA)	Power Supply		Max. Fuse Or HACR Breaker Size
			Field Wire		
			Quantity	Wire Gauge 75C	
075B	208	378	6	250	450
	230	362	6	4/0	400
	380	194	3	3/0	225
	460	187	3	3/0	225
	575	145	3	1/0	175
085B	208	398	6	250	450
	230	382	6	250	450
	380	234	3	250	250
	460	200	3	4/0	225
	575	151	3	1/0	175
090B	208	416	6	300	500
	230	401	6	350	450
	380	270	3	300	300
	460	211	3	4/0	250
	575	157	3	2/0	175
100B	208	522	6	400	600
	230	462	6	350	500
	380	273	3	300	300
	460	230	3	4/0	250
	575	187	3	3/0	200
110B	208	612	6 - (2)	350	700
	230	526	6 - (2)	300	600
	380	307	3	350	350
	460	263	3	300	300
	575	211	3	4/0	225
120B	208	612	6 - (2)	350	700
	230	571	6 - (2)	350	600
	380	352	6 - (2)	4/0	400
	460	286	3	350	300
	575	219	3	4/0	250
130B	208	613	6 - (2)	350	700
	230	613	6 - (2)	350	700
	380	393	6	250	450
	460	307	3	350	350
	575	228	3	250	250

NOTES:

1. All Electrical Data notes are on page 39.
2. (2) in column with wire qty. indicates that two conduits are required.
3. Conduit hubs are not supplied.

Table 42, AGZ 075BB/BH – 130BB/BH, Compressor and Fan Motor Amps, Single and Multi-Point (106°F to 125°F)

AGZ Unit Size	Volts	Rated Load Amps							No. of Fan Motors	Locked Rotor Amps						
		Compressors						F.L.Amps Fan Motors (Each)		R.L.Amps Fan Motors (Each)	Compressors					
		No. 1	No. 3	No. 5	No. 2	No. 4	No. 6				Across-The-Line					
											No.1	No. 3	No. 5	No.2	No.4	No. 6
075B	208	78.0	78.0	-	78.0	78.0	-	7.8	6	31.7	505	505	-	505	505	-
	230	74.1	74.1	-	74.1	74.1	-	7.8	6	35.6	505	505	-	505	505	-
	380	39.8	39.8	-	39.8	39.8	-	4.1	6	20.0	280	280	-	280	280	-
	460	38.8	38.8	-	38.8	38.8	-	3.6	6	17.8	225	225	-	225	225	-
	575	29.9	29.9	-	29.9	29.9	-	3.0	6	14.0	180	180	-	180	180	-
085B	208	78.0	78.0	-	86.9	86.9	-	7.8	6	31.7	505	505	-	500	500	-
	230	74.1	74.1	-	83.3	83.3	-	7.8	6	35.6	505	505	-	500	500	-
	380	39.8	39.8	-	57.6	57.6	-	4.1	6	20.0	280	280	-	305	305	-
	460	38.8	38.8	-	44.5	44.5	-	3.6	6	17.8	225	225	-	250	250	-
	575	29.9	29.9	-	32.5	32.5	-	3.0	6	14.0	180	180	-	198	198	-
090B	208	86.9	86.9	-	86.9	86.9	-	7.8	6	31.7	500	500	-	500	500	-
	230	83.3	83.3	-	83.3	83.3	-	7.8	6	35.6	500	500	-	500	500	-
	380	57.6	57.6	-	57.6	57.6	-	4.1	6	20.0	305	305	-	305	305	-
	460	44.5	44.5	-	44.5	44.5	-	3.6	6	17.8	250	250	-	250	250	-
	575	32.5	32.5	-	32.5	32.5	-	3.0	6	14.0	198	198	-	198	198	-
100B	208	58.1	58.1	58.1	87.9	87.9	87.9	7.8	8	31.7	425	425	425	505	505	505
	230	52.8	52.8	52.8	74.2	74.2	74.2	7.8	8	35.6	425	425	425	505	505	505
	380	32.7	32.7	32.7	43.8	43.8	43.8	4.1	8	20.0	239	239	239	280	280	280
	460	25.5	25.5	25.5	37.5	37.5	37.5	3.6	8	17.8	187	187	187	225	225	225
	575	21.8	21.8	21.8	29.9	29.9	29.9	3.0	8	14.0	148	148	148	180	180	180
110B	208	87.9	87.9	87.9	87.9	87.9	87.9	7.8	8	31.7	505	505	505	505	505	505
	230	74.2	74.2	74.2	74.2	74.2	74.2	7.8	8	35.6	505	505	505	505	505	505
	380	43.8	43.8	43.8	43.8	43.8	43.8	4.1	8	20.0	280	280	280	280	280	280
	460	37.5	37.5	37.5	37.5	37.5	37.5	3.6	8	17.8	225	225	225	225	225	225
	575	29.9	29.9	29.9	29.9	29.9	29.9	3.0	8	14.0	180	180	180	180	180	180
120B	208	87.9	87.9	87.9	88.0	88.0	88.0	7.8	8	31.7	505	505	505	500	500	500
	230	74.2	74.2	74.2	88.0	88.0	88.0	7.8	8	35.6	505	505	505	500	500	500
	380	43.8	43.8	43.8	57.6	57.6	57.6	4.1	8	20.0	280	280	280	305	305	305
	460	37.5	37.5	37.5	44.5	44.5	44.5	3.6	8	17.8	225	225	225	250	250	250
	575	29.9	29.9	29.9	32.5	32.5	32.5	3.0	8	14.0	180	180	180	198	198	198
130B	208	88.0	88.0	88.0	88.0	88.0	88.0	7.8	8	31.7	500	500	500	500	500	500
	230	88.0	88.0	88.0	88.0	88.0	88.0	7.8	8	35.6	500	500	500	500	500	500
	380	57.6	57.6	57.6	57.6	57.6	57.6	4.1	8	20.0	305	305	305	305	305	305
	460	44.5	44.5	44.5	44.5	44.5	44.5	3.6	8	17.8	250	250	250	250	250	250
	575	32.5	32.5	32.5	32.5	32.5	32.5	3.0	8	14.0	198	198	198	198	198	198

NOTE: All Electrical Data notes are on page 39.

Table 43, AGZ 075BB/BH – 130BB/BH, Electrical Data, Multi-Point (106°F)

AGZ Unit Size	Volts	Electrical Circuit #1				Electrical Circuit #2			
		Minimum Circuit Ampacity (MCA)	Power Supply Field Wire		Max. Fuse or HACR Breaker Size	Minimum Circuit Ampacity (MCA)	Power Supply Field Wire		Max. Fuse or HACR Breaker Size
			Qty	Wire Gauge 75C			Qty	Wire Gauge 75C	
075B	208	199	3	3/0	250	199	3	3/0	250
	230	190	3	3/0	250	190	3	3/0	250
	380	102	3	#2	125	102	3	#2	125
	460	99	3	#3	125	99	3	#3	125
	575	76	3	#4	100	76	3	#4	100
085B	208	199	3	3/0	250	219	3	4/0	300
	230	190	3	3/0	250	211	3	4/0	250
	380	102	3	#2	125	142	3	1/0	175
	460	99	3	#3	125	111	3	#2	150
	575	76	3	#4	100	83	3	#3	110
090B	208	219	3	4/0	300	219	3	4/0	300
	230	211	3	4/0	250	211	3	4/0	250
	380	142	3	1/0	175	142	3	1/0	175
	460	111	3	#2	150	111	3	#2	150
	575	83	3	#3	110	83	3	#3	110
100B	208	220	3	4/0	250	317	3	400	400
	230	203	3	4/0	250	272	3	300	300
	380	123	3	#1	150	159	3	2/0	200
	460	101	3	#2	125	136	3	1/0	175
	575	83	3	#4	100	109	3	#2	125
110B	208	317	3	400	400	317	3	400	400
	230	272	3	300	300	272	3	300	300
	380	159	3	2/0	200	159	3	2/0	200
	460	136	3	1/0	175	136	3	1/0	175
	575	109	3	#2	125	109	3	#2	125
120B	208	317	3	400	400	317	3	400	400
	230	272	3	300	300	317	3	400	400
	380	159	3	2/0	200	204	3	4/0	250
	460	136	3	1/0	175	159	3	2/0	200
	575	109	3	#2	125	118	3	#1	150
130B	208	317	3	400	400	317	3	400	400
	230	317	3	400	400	317	3	400	400
	380	204	3	4/0	250	204	3	4/0	250
	460	159	3	2/0	200	159	3	2/0	200
	575	118	3	#1	150	118	3	#1	150

NOTES:

1. All Electrical Data notes are on page 39.
2. Conduit hubs are not supplied.

Figure 10, AGZ 010 - AGZ 034, Typical Field Wiring

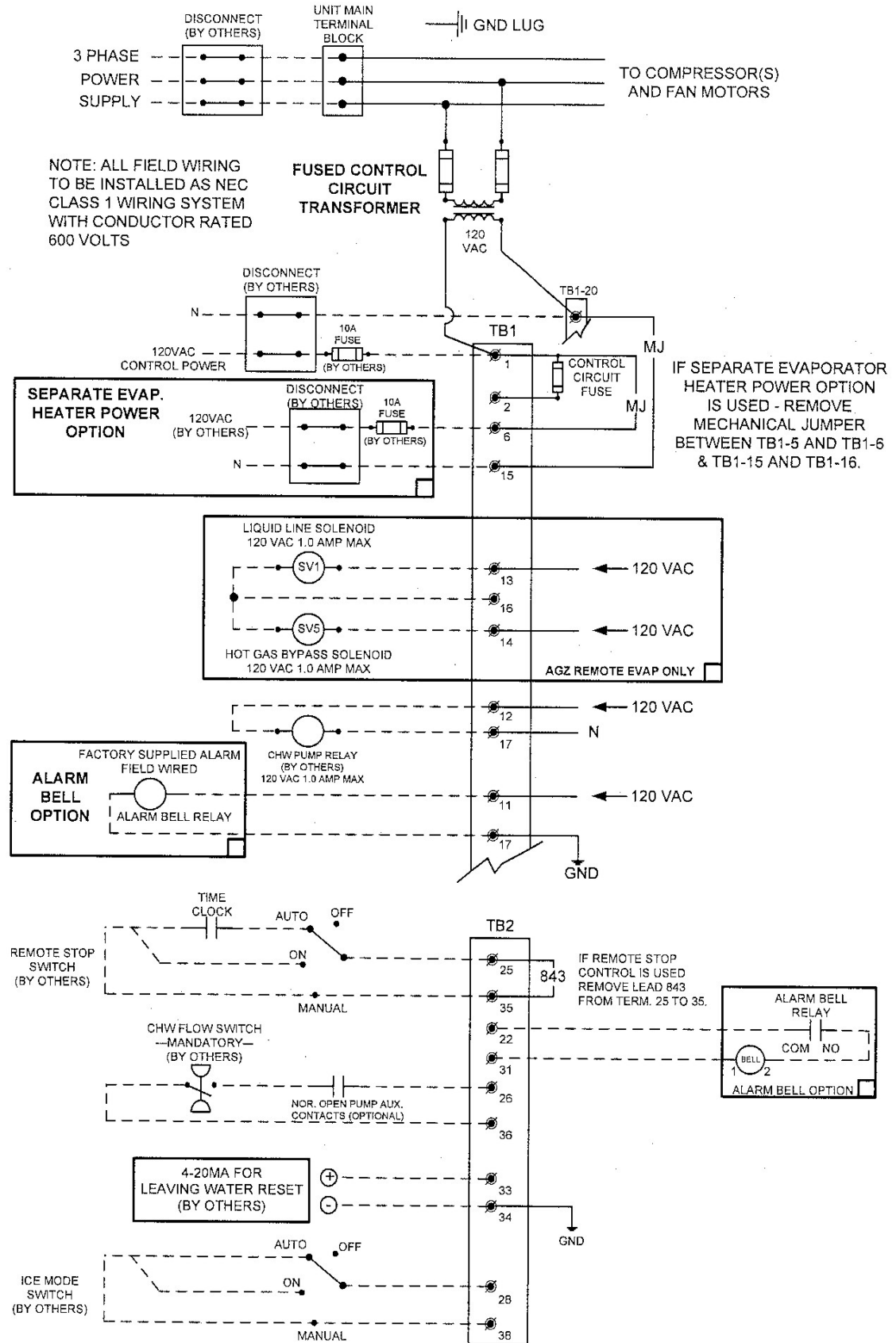

330538401 0B

Figure 11, AGZ 026B – AGZ 130B, Typical Field Wiring

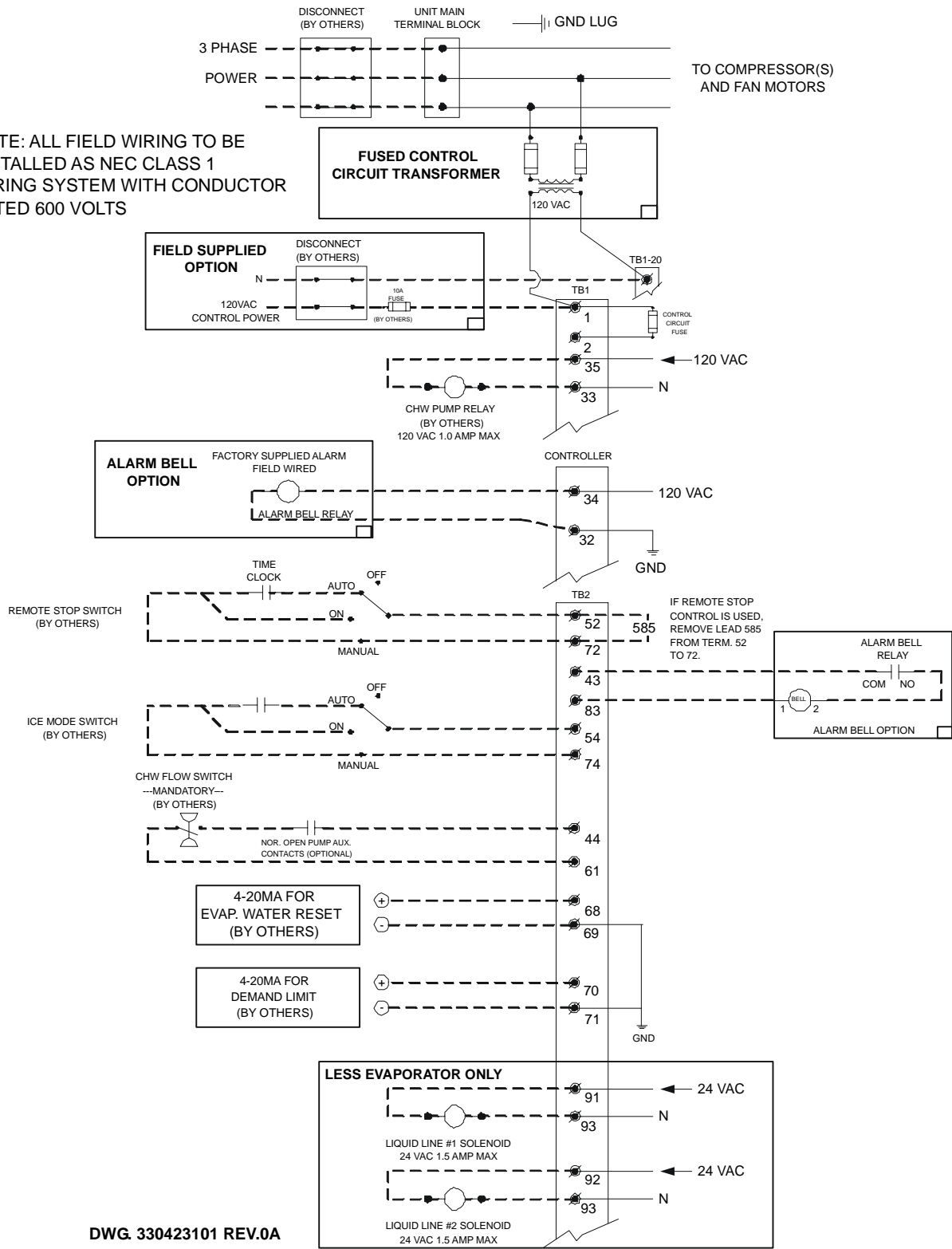

DWG. 330423101 REV.0A

Physical Data

AGZ, Packaged

Table 44, Physical Data, AGZ 010A through 017A

PHYSICAL DATA	AGZ MODEL NUMBER		
	010A	013A	017A
BASIC DATA			
Unit Capacity @ ARI Conditions (1), Tons (kW)	9.8 (34.3)	13.3 (46.6)	15.9 (55.7)
Number Of Refrigerant Circuits	1	1	1
Unit Operating Charge, R-22, Lb. (kg)	22.0 (10.0)	24.0 (10.9)	31.0 (14.1)
Cabinet Dimensions, LxWxH, In.	73.6 x 46.3 x 49.0	73.6 x 46.3 x 49.0	73.6 x 46.3 x 49.0
Cabinet Dimensions, LxWxH, (mm)	(1869 x 1176 x 1245)	(1869 x 1176 x 1245)	(1869 x 1176 x 1245)
Unit Operating Weight, Lb. (kg)	1008 (458)	1364 (619)	1387 (630)
Unit Shipping Weight, Lb. (kg)	1075 (488)	1425 (647)	1450 (658)
Add'l Weight If Copper Finned Coils, Lb. (kg)	220 (99.7)	220 (99.7)	220 (99.7)
COMPRESSORS			
Type	Scroll	Scroll	Scroll
Nominal Tons Per Compressor	6.0 / 6.0	7.5 / 7.5	9.0 / 9.0
Oil Charge Per Compressor, Oz. (g)	60 (1701)	140 (3969)	140 (3969)
CAPACITY REDUCTION STEPS - PERCENT OF COMPRESSOR DSPLACEMENT			
Standard Staging	0 – 50 – 100	0 – 50 – 100	0 – 50 – 100
CONDENSERS - HIGH EFFICIENCY FIN AND TUBE TYPE WITH INTEGRAL SUBCOOLING			
Coil Face Area Sq. Ft. (M ²)	30.3 (2.8)	30.3 (2.8)	30.3 (2.8)
Finned Height x Finned Length, In.	84 x 52	84 x 52	84 x 52
Finned Height x Finned Length, (mm)	(2134) x (1321)	(2134) x (1321)	(2134) x (1321)
Fins Per Inch x Rows Deep	16 x 2	16 x 3	16 x 3
Pumpdown Capacity Lb. (kg)	35.3 (16.0)	50.3 (22.8)	50.3 (22.8)
CONDENSER FANS - DIRECT DRIVE PROPELLER TYPE			
Number Of Fans - Fan Diameter, In. (mm)	2 – 26 (660)	2 – 26 (660)	2 – 26 (660)
Number Of Motors - HP (kW)	2 – 1.0 (0.75)	2 – 1.0 (0.75)	2 – 1.0 (0.75)
Fan And Motor RPM, 60 Hz	1140	1140	1140
60 Hz Total Unit Airflow, CFM (l/s)	13950 (6584)	12000 (5664)	12000 (5664)
DIRECT EXPANSION EVAPORATOR - BRAZED PLATE-TO-PLATE			
Connection Size Victaulic, In. (mm)	2 (51)	2 (51)	2 (51)
Water Volume, Gallons (L)	.94 (3.6)	1.66 (6.3)	2.00 (7.6)
Maximum Refrigerant Working Pressure, psig (kPa)	450 (3103)	450 (3103)	450 (3103)
Maximum Water Pressure, psig (kPa)	450 (3103)	450 (3103)	450 (3103)

NOTE: Nominal capacity based on 95°F ambient air temperature and 54°F/44°F water range.

Table 45, Physical Data, AGZ 020A through 034A

PHYSICAL DATA	AGZ MODEL NUMBER			
	020A	025A	029A	034A
BASIC DATA				
Unit Capacity @ ARI Conditions (1), Tons (kW)	20.4 (71.4)	22.7 (79.5)	28.3 (98.7)	34.0 (119.0)
Number Of Refrigerant Circuits	1	1	1	1
Unit Operating Charge, R-22, Lb. (kg)	34.0 (15.4)	36.0 (16.3)	47.0 (21.3)	50.0 (22.7)
Cabinet Dimensions, LxWxH, In.	106.2x 46.3 x 49.0	106.2x 46.3 x 49.0	106.2x 46.3 x 57.0	106.2x 46.3 x 57.0
Cabinet Dimensions, LxWxH, (mm)	(2697 x 1176 x 1245)	(2697 x 1176 x 1245)	(2697 x 1176 x 1248)	(2697 x 1176 x 1248)
Unit Operating Weight, Lbs. (kg)	1569 (712)	1626 (738)	1810 (822)	2072 (941)
Unit Shipping Weight, Lbs. (kg)	1650 (749)	1700 (772)	1875 (851)	2125 (965)
Add'l Weight If Copper Finned Coils, Lb. (kg)	350 (159)	350 (159)	435 (197)	435 (197)
COMPRESSORS				
Type	Scroll	Scroll	Scroll	Scroll
Nominal Horsepower	10.0 / 13.0	13.0 / 13.0	15.0 / 15.0	20.0 / 20.0
Oil Charge Per Compressor, Oz. (g)	140 (3969)	140 (3969)	140 (3969)	296 (8392)
CAPACITY REDUCTION STEPS - PERCENT OF COMPRESSOR DISPLACEMENT				
Standard Staging	0 – 45 - 100	0 – 50 – 100	0 – 50 – 100	0 – 50 – 100
CONDENSERS - HIGH EFFICIENCY FIN AND TUBE TYPE WITH INTEGRAL SUBCOOLING				
Coil Face Area Sq. Ft. (M ²)	49.0 (4.6)	49.0 (4.6)	58.3 (5.4)	58.3 (5.4)
Finned Height x Finned Length, In.	84 x 84	84 x 84	100 x 84	100 x 84
Finned Height x Finned Length, (mm)	(2134) x (2134)	(2134) x (2134)	(2545) x (2134)	(2545) x (2134)
Fins Per Inch x Rows Deep	16 x 2	16 x 2	16 x 3	16 x 3
Pumpdown Capacity lb. (kg)	53.1 (24.0)	53.1 (24.0)	90.7 (41.1)	92.8 (42.0)
CONDENSER FANS - DIRECT DRIVE PROPELLER TYPE				
Number Of Fans - Fan Diameter, In. (mm)	3 – 26 (660)	3 – 26 (660)	3 – 26 (660)	3 – 26 (660)
Number Of Motors - HP (kW)	3 – 1.0 (0.75)	3 – 1.0 (0.75)	3 – 1.0 (0.75)	3 – 1.0 (0.75)
Fan And Motor RPM, 60 Hz	1140	1140	1140	1140
60 Hz Total Unit Airflow, CFM (l/s)	20925 (9877)	20925 (9877)	19800 (9346)	19800 (9346)
DIRECT EXPANSION EVAPORATOR - BRAZED PLATE-TO-PLATE				
Connection Size Victaulic, In. (mm)	2 (51)	2 (51)	2 (51)	2 (51)
Water Volume, Gallons (L)	2.16 (8.2)	3.05 (11.5)	4.00 (15.1)	5.55 (21.0)
Max. Refrigerant Working Pressure, psig (kPa)	450 (3103)	450 (3103)	450 (3103)	450 (3103)
Maximum Water Pressure, psig (kPa)	450 (3103)	450 (3103)	450 (3103)	450 (3103)

NOTE: Nominal capacity based on 95°F ambient air temperature and 54°F/44°F water range.

Table 46, AGZ 026BS through 035BS

PHYSICAL DATA	AGZ MODEL NUMBER					
	026B		030B		035B	
BASIC DATA	Ckt.1	Ckt.2	Ckt.1	Ckt.2	Ckt.1	Ckt.2
Unit Capacity @ ARI (1), Tons (kW)	27.2 (95.4)		30.2 (106.3)		33.2 (117.2)	
Number Of Refrigerant Circuits	2		2		2	
Unit Operating Charge, R-22, Lbs.	22	22	22	27	27	27
Unit Operating Charge, R-22, (kg)	10	10	10	12	12	12
Cabinet Dimensions, LxWxH, In.	94.4 x 88.0 x 100.4		94.4 x 88.0 x 100.4		94.4 x 88.0 x 100.4	
Cabinet Dimensions, LxWxH, (mm)	(2398 x 2235 x 2550)		(2398 x 2235 x 2550)		(2398 x 2235 x 2550)	
Unit Operating Weight, Lb (kg)	3990 (1811)		4040 (1834)		4080 (1852)	
Unit Shipping Weight, Lb (kg)	3950 (1793)		3990 (1811)		4030 (1830)	
Add'l Weight If Copper Finned Coils, Lb (kg)	284 (129)		284 (129)		284 (129)	
COMPRESSORS						
Type	Tandem Scrolls		Tandem Scrolls		Tandem Scrolls	
Nominal tonnage of each Compressor	7.5	7.5	7.5	9.0	9.0	9.0
Number Of Compressors per Circuit	2	2	2	2	2	2
Oil Charge Per Compressor, Oz.	140	140	140	140	140	140
Oil Charge Per Compressor, (g)	(496)	(496)	(496)	(496)	(496)	(496)
CAPACITY REDUCTION STEPS - PERCENT OF COMPRESSOR DISPLACEMENT						
Staging, 4 Stages, Circuit #1 in Lead	0-25-50-75-100		0-23-50-73-100		0-25-50-75-100	
Staging, 4 Stages, Circuit #2 in Lead	0-25-50-75-100		0-27-50-77-100		0-25-50-75-100	
CONDENSERS - HIGH EFFICIENCY FIN AND TUBE TYPE WITH INTEGRAL SUBCOOLING						
Coil Face Area Sq. Ft.	26.3	26.3	26.3	26.3	26.3	26.3
Coil Face Area, (M ²)	2.4	2.4	2.4	2.4	2.4	2.4
Finned Height x Finned Length, In.	50x75.6	50x75.6	50x75.6	50x75.6	50x75.6	50x75.6
Finned Height x Finned Length, (mm)	1270 x 1920	1270 x 1920	1270 x 1920	1270 x 1920	1270 x 1920	1270 x 1920
Fins Per Inch x Rows Deep	16 x 3	16 x 3	16 x 3	16 x 3	16 x 3	16 x 3
Pumpdown Capacity, 90% Full Lbs. (kg)	49 (22)	49 (22)	49 (22)	49 (22)	49 (22)	49 (22)
Maximum Relief Valve Pressure Setting, psig (kPa)	450 (3103)	450 (3103)	450 (3103)	450 (3103)	450 (3103)	450 (3103)
CONDENSER FANS - DIRECT DRIVE PROPELLER TYPE						
Number Of Fans - Fan Diameter, In. (mm)	4 – 30 (762)		4 – 30 (762)		4 – 30 (762)	
Number Of Motors - HP (kW) (2)	4 – 1.5		4 – 1.5		4 – 1.5	
Fan And Motor RPM, 60Hz	1140		1140		1140	
60 Hz Fan Tip Speed, FPM (M/Sec)	8950 (4224)		8950 (4224)		8950 (4224)	
60 Hz Total Unit Airflow, CFM (M ³ /sec)	24,316 (11,478)		24,316 (11,478)		24,316 (11,478)	
EVAPORATOR - BRAZED PLATE-TO-PLATE						
Number of Evaporators	1		1		1	
Number of Refrigerant Circuits	2		2		2	
Water Volume, Gallons, (L)	3.9 (14.7)		5.0 (18.9)		4.3 (16.4)	
Maximum Water Pressure, psig (kPa)	363 (2503)		363 (2503)		363 (2503)	
Max. Refrig. Working Pressure, psig (kPa)	450 (3102)		450 (3102)		450 (3102)	
Water Inlet / Outlet Victaulic Conn. In. (mm)	3 (76)		3 (76)		3 (76)	
Drain - NPT int, In. (mm)	Field		Field		Field	
Vent - NPT int, In. (mm)	Field		Field		Field	

NOTES:

1. Nominal capacity based on 95°F ambient air and 54°F/44°F water range.
2. Except for 380V/60 & 575V/60, HP = 2.0

Table 47, AGZ 040BS through 055BS

PHYSICAL DATA	AGZ MODEL NUMBER							
	040B		045B		050B		055B	
BASIC DATA	Ckt.1	Ckt.1	Ckt.2	Ckt.1	Ckt.2	Ckt.1	Ckt.2	Ckt.2
Unit Capacity @ ARI Conditions (1), Tons (kW)	38.5 (135.5)		42.5 (149.6)		47.0 (165.4)		52.2 (183.7)	
Number Of Refrigerant Circuits	2		2		2		2	
Unit Operating Charge, R-22, lbs.	31	31	38	38	38	38	46	46
Unit Operating Charge, R-22, (kg)	(14)	(14)	(17)	(17)	(17)	(17)	(21)	(21)
Cabinet Dimensions, LxWxH, in.	94.4 x 88.0 x 100.4		94.4 x 88.0 x 100.4		94.4 x 88.0 x 100.4		94.4 x 88.0 x 100.4	
Cabinet Dimensions, LxWxH, (mm)	(2398 x 2235 x 2550)		(2398 x 2235 x 2550)		(2398 x 2235 x 2550)		(2398 x 2235 x 2550)	
Unit Operating Weight, Lbs. (kg)	4130 (1875)		4270 (1939)		4400 (1998)		4540 (2061)	
Unit Shipping Weight, Lbs. (kg)	4070 (1848)		4210 (1911)		4330 (1966)		4460 (2025)	
Add'l Weight If Copper Finned Coils, lbs. (kg)	288 (130)		288 (130)		476 (130)		476 (130)	
COMPRESSORS								
Type	Tandem Scrolls		Tandem Scrolls		Tandem Scrolls		Tandem Scrolls	
Nominal tonnage of each Compressor	10.0	10.0	10.0	13.0	13.0	13.0	13.0	15.0
Number Of Compressors per Circuit	2	2	2	2	2	2	2	2
Oil Charge Per Compressor, oz.	140	140	140	140	140	140	140	140
Oil Charge Per Compressor, (g)	(496)	(496)	(496)	(496)	(496)	(496)	(496)	(496)
CAPACITY REDUCTION STEPS - PERCENT OF COMPRESSOR DISPLACEMENT								
Staging, 4 Stages, Circuit #1 in Lead	0-25-50-75-100		0-22-50-46-100		0-25-50-75-100		0-25-50-75-100	
Staging, 4 Stages, Circuit #2 in Lead	0-25-50-75-100		0-28-50-85-100		0-25-50-75-100		0-25-50-75-100	
CONDENSERS - HIGH EFFICIENCY FIN AND TUBE TYPE WITH INTEGRAL SUBCOOLING								
Coil Face Area, sq. ft.	44.1	44.1	44.1	44.1	44.1	44.1	44.1	44.1
Coil Face Area , sq. m	4.1	4.1	4.1	4.1	4.1	4.1	4.1	4.1
Finned Height x Finned Length, in.	42x75.6	42x75.6	42x75.6	42x75.6	42x75.6	42x75.6	42x75.6	42x75.6
Finned Height x Finned Length, (mm)	1067 x 1920	1067 x 1920	1067 x 1920	1067 x 1920	1067 x 1920	1067 x 1920	1067 x 1920	1067 x 1920
Fins Per Inch x Rows Deep	16 x 2	16 x 2	16 x 2	16 x 2	16 x 3	16 x 3	16 x 3	16 x 3
Pumpdown Capacity, 90% Full Lbs. (kg)	60 (27)	60 (27)	60(27)	60(27)	82 (37)	82 (37)	82 (37)	82 (37)
Maximum Relief Valve Pressure Setting, psig (kPa)	450 (3103)	450 (3103)	450 (3103)	450 (3103)	450 (3103)	450 (3103)	450 (3103)	450 (3103)
CONDENSER FANS - DIRECT DRIVE PROPELLER TYPE								
Number Of Fans - Fan Diameter, in. (mm)	4 – 30 (762)		4 – 30 (762)		4 – 30 (762)		4 – 30 (762)	
Number Of Motors - HP (kW) (2)	4 – 1.5		4 – 1.5		4 – 1.5		4 – 1.5	
Fan And Motor RPM, 60Hz	1140		1140		1140		1140	
60 Hz Fan Tip Speed, FPM (m/sec)	8950 (4224)		8950 (4224)		8950 (4224)		8950 (4224)	
60 Hz Total Unit Airflow, CFM (m ³ /sec)	39,600 (18,692)		39,600 (18,692)		39,600 (18,692)		39,600 (18,692)	
EVAPORATOR - BRAZED PLATE-TO-PLATE								
Number of Evaporators	1		1		1		1	
Number of Refrigerant Circuits	2		2		2		2	
Water Volume, Gallons, (L)	5.0 (18.9)		5.7 (21.4)		6.3 (23.9)		7.2 (27.3)	
Maximum Water Pressure, psig (kPa)	363 (2503)		363 (2503)		363 (2503)		363 (2503)	
Maximum Refrigerant Working Pressure, psig (kPa)	450 (3102)		450 (3102)		450 (3102)		450 (3102)	
Water Inlet / Outlet Victaulic Connections, in. (mm)	3 (76)		3 (76)		3 (76)		3 (76)	
Drain - NPT int, in. (mm)	Field		Field		Field		Field	
Vent - NPT int, in. (mm)	Field		Field		Field		Field	

NOTES:

1. Nominal capacity based on 95°F ambient air and 54°F/44°F water range.
2. Except for 380V/60 & 575V/60, HP = 2.0

Table 48, AGZ 060BS through 070BS

PHYSICAL DATA	AGZ MODEL NUMBER					
	060B		065B		070B	
BASIC DATA	Ckt.1	Ckt.2	Ckt.1	Ckt.2	Ckt.1	Ckt.2
Unit Capacity @ ARI Conditions (1), Tons (kW)	57.1 (201.0)		61.4 (215.5)		65.5 (230.0)	
Number Of Refrigerant Circuits	2		2		2	
Unit Operating Charge, R-22, lbs.	46	46	52	59	59	59
Unit Operating Charge, R-22, (kg)	(21)	(21)	(24)	(27)	(27)	(27)
Cabinet Dimensions, LxWxH, in.	94.4 x 88.0 x 100.4		94.4 x 88.0 x 100.4		94.4 x 88.0 x 100.4	
Cabinet Dimensions, LxWxH, (mm)	(2398 x 2235 x 2550)		(2398 x 2235 x 2550)		(2398 x 2235 x 2550)	
Unit Operating Weight, Lbs. (kg)	4600 (2086)		4860 (2204)		4990 (2263)	
Unit Shipping Weight, Lbs. (kg)	4520 (2050)		4760 (2159)		4890 (2218)	
Add'l Weight If Copper Finned Coils, lbs. (kg)	476 (216)		568 (258)		568 (258)	
COMPRESSORS						
Type	Tandem Scrolls		Tandem Scrolls		Tandem Scrolls	
Nominal tonnage of each Compressor	15.0	15.0	15.0	15 / 20	15 / 20	15 / 20
Number Of Compressors per Circuit	2	2	2	2	2	2
Oil Charge Per Compressor, oz.	140	140	140	140 /148	140 /148	140 /148
Oil Charge Per Compressor, (g)	(496)	(496)	(496)	496/ 525	496/ 525	496/ 525
CAPACITY REDUCTION STEPS - PERCENT OF COMPRESSOR DISPLACEMENT						
Staging, 4 Stages, Circuit #1 in Lead	0-25-50-75-100		0-23-46-77-100		0-25-50-75-100	
Staging, 4 Stages, Circuit #2 in Lead	0-25-50-75-100		0-31-46-69-100		0-25-50-75-100	
CONDENSERS - HIGH EFFICIENCY FIN AND TUBE TYPE WITH INTEGRAL SUBCOOLING						
Coil Face Area, sq. ft.	44.1	44.1	52.6	52.6	52.6	52.6
Coil Face Area, (m ²)	4.1	4.1	4.9	4.9	4.9	4.9
Finned Height x Finned Length, in.	42x75.6	42x75.6	50x75.6	50x75.6	50x75.6	50x75.6
Finned Height x Finned Length, (mm)	1067 x 1920	1067 x 1920	1270 x 1920	1270 x 1920	1270 x 1920	1270 x 1920
Fins Per Inch x Rows Deep	16 x 3	16 x 3	16 x 3	16 x 3	16 x 3	16 x 3
Pumpdown Capacity, 90% Full Lbs. (kg)	82 (37)	82 (37)	98 (44)	98 (44)	98 (44)	98 (44)
Maximum Relief Valve Pressure Setting, psig (kPa)	450 (3103)	450 (3103)	450 (3103)	450 (3103)	450 (3103)	450 (3103)
CONDENSER FANS - DIRECT DRIVE PROPELLER TYPE						
Number Of Fans - Fan Diameter, in. (mm)	4 – 30 (762)		4 – 30 (762)		4 – 30 (762)	
Number Of Motors - HP (kW) (2)	4 – 1.5		4 – 2.0		4 – 2.0	
Fan And Motor RPM, 60Hz	1140		1140		1140	
60 Hz Fan Tip Speed, FPM (m/sec)	8950 (4224)		8950 (4224)		8950 (4224)	
60 Hz Total Unit Airflow, CFM (m ³ /sec)	37,228 (17,572)		43,452 (20,510)		43,452 (20,510)	
EVAPORATOR - BRAZED PLATE-TO-PLATE						
Number of Evaporators	1		1		1	
Number of Refrigerant Circuits	2		2		2	
Water Volume, Gallons, (L)	8.1 (30.7)		9.2 (34.9)		9.2 (34.9)	
Maximum Water Pressure, psig (kPa)	363 (2503)		363 (2503)		363 (2503)	
Maximum Refrigerant Working Pressure, psig (kPa)	450 (3102)		450 (3102)		450 (3102)	
Water Inlet / Outlet Victaulic Connections, in. (mm)	3 (76)		3 (76)		3 (76)	
Drain - NPT int, in. (mm)	Field		Field		Field	
Vent - NPT int, in. (mm)	Field		Field		Field	

NOTES:

1. Nominal capacity based on 95°F ambient air and 54°F/44°F water range
2. Except for 380V/60 & 575V/60 for AGZ 060, HP = 2.0

Table 49, AGZ 075BS through 090BS

PHYSICAL DATA	AGZ MODEL NUMBER					
	075B		085B		090B	
BASIC DATA	Ckt.1	Ckt.2	Ckt.1	Ckt.2	Ckt.1	Ckt.2
Unit Capacity @ ARI Conditions (1), Tons (kW)	73.7 (259.4)		79.6 (280.2)		85.5 (301.0)	
Number Of Refrigerant Circuits	2		2		2	
Unit Operating Charge, R-22, lbs.	59	59	59	69	69	69
Unit Operating Charge, R-22, (kg)	(27)	(27)	(27)	(31)	(31)	(31)
Cabinet Dimensions, LxWxH, in.	134.9 x 88.0 x 100.4		134.9 x 88.0 x 100.4		134.9 x 88.0 x 100.4	
Cabinet Dimensions, LxWxH, (mm)	(3426 x 2235 x 2550)		(3426 x 2235 x 2550)		(3426 x 2235 x 2550)	
Unit Operating Weight, Lbs. (kg)	6530 (2958)		6690 (3031)		6850 (3103)	
Unit Shipping Weight, Lbs. (kg)	6320 (2863)		6480 (2935)		6640 (3008)	
Add'l Weight If Copper Finned Coils, lbs. (kg)	870 (395)		870 (395)		870 (395)	
COMPRESSORS						
Type	Tandem Scrolls		Tandem Scrolls		Tandem Scrolls	
Nominal tonnage of each Compressor	20.0	20.0	20.0	25.0	25.0	25.0
Number Of Compressors per Circuit	2	2	2	2	2	2
Oil Charge Per Compressor, oz.	148	148	148	200	200	200
Oil Charge Per Compressor, (g)	(525)	(525)	(525)	(709)	(709)	(709)
CAPACITY REDUCTION STEPS - PERCENT OF COMPRESSOR DISPLACEMENT						
Staging, 4 Stages, Circuit #1 in Lead	0-25-50-75-100		0-22-50-72-100		0-25-50-75-100	
Staging, 4 Stages, Circuit #2 in Lead	0-25-50-75-100		0-28-50-78-100		0-25-50-75-100	
CONDENSERS - HIGH EFFICIENCY FIN AND TUBE TYPE WITH INTEGRAL SUBCOOLING						
Coil Face Area, sq. ft.	78.8	78.8	78.8	78.8	78.8	78.8
Coil Face Area, (m ²)	7.3	7.3	7.3	7.3	7.3	7.3
Finned Height x Finned Length, in.	50 x113.4	50 x113.4	50 x113.4	50 x113.4	50 x113.4	50 x113.4
Finned Height x Finned Length, (mm)	1270 x 2880	1270 x 2880	1270 x 2880	1270 x 2880	1270 x 2880	1270 x 2880
Fins Per Inch x Rows Deep	16 x 3	16 x 3	16 x 3	16 x 3	16 x 3	16 x 3
Pumpdown Capacity, 90% Full Lbs. (kg)	147 (67)	147 (67)	147 (67)	147 (67)	147 (67)	147 (67)
Maximum Relief Valve Pressure Setting, psig (kPa)	450 (3103)	450 (3103)	450 (3103)	450 (3103)	450 (3103)	450 (3103)
CONDENSER FANS - DIRECT DRIVE PROPELLER TYPE						
Number Of Fans - Fan Diameter, in. (mm)	6 – 30 (762)		6 – 30 (762)		6 – 30 (762)	
Number Of Motors - HP (kW)	6 – 2.0		6 – 2.0		6 – 2.0	
Fan And Motor RPM, 60Hz	1140		1140		1140	
60 Hz Fan Tip Speed, FPM (m/sec)	8950 (4224)		8950 (4224)		8950 (4224)	
60 Hz Total Unit Airflow, CFM (m ³ /sec)	65,178 (30,765)		65,178 (30,765)		65,178 (30,765)	
EVAPORATOR - SHELL AND TUBE						
Number of Evaporators	1		1		1	
Number of Refrigerant Circuits	2		2		2	
Diameter, in. - Length, ft.	14.0 x 5.2		14.0 x 5.2		14.0 x 5.2	
Diameter, (mm) – Length, (mm)	356 x 1585		356 x 1585		356 x 1585	
Water Volume, Gallons, (L)	25 (95)		25 (95)		25 (95)	
Maximum Water Pressure, psig (kPa)	152 (1047)		152 (1047)		152 (1047)	
Maximum Refrigerant Working Pressure, psig (kPa)	300 (2066)		300 (2066)		300 (2066)	
Water Inlet / Outlet Victaulic Connections, in. (mm)	5 (127)		5 (127)		5 (127)	
Drain - NPT int, in. (mm)	0.5 (12.7)		0.5 (12.7)		0.5 (12.7)	
Vent - NPT int, in. (mm)	0.5 (12.7)		0.5 (12.7)		0.5 (12.7)	

NOTE: Nominal capacity based on 95°F ambient air and 54°F/44°F water range.

Table 5, AGZ 100BS through 130BS

PHYSICAL DATA	AGZ MODEL NUMBER							
	100B		110B		120B		130B	
BASIC DATA	Ckt.1	Ckt.2	Ckt.1	Ckt.2	Ckt.1	Ckt.2	Ckt.1	Ckt.2
Unit Capacity @ ARI Conditions (1), Tons (kW)	97.6 (342.6)		107.5 (378.4)		119.8 (421.7)		129.4 (455.5)	
Number Of Refrigerant Circuits	2		2		2		2	
Unit Operating Charge, R-22, lbs.	76	86	86	86	86	104	104	104
Unit Operating Charge, R-22, (kg)	(35)	(39)	(39)	(39)	(39)	(47)	(47)	(47)
Cabinet Dimensions, LxWxH, in.	173.1 x 88.0 x 100.4		173.1 x 88.0 x 100.4		173.1 x 88.0 x 100.4		173.1 x 88.0 x 100.4	
Cabinet Dimensions, LxWxH, (mm)	(4397 x 2235 x 2550)		(4397 x 2235 x 2550)		(4397 x 2235 x 2550)		(4397 x 2235 x 2550)	
Unit Operating Weight, Lbs. (kg)	7870 (3565)		8150 (3692)		8720 (3950)		9050 (4100)	
Unit Shipping Weight, Lbs. (kg)	7580 (3434)		7860 (3561)		8380 (3796)		8710 (3946)	
Add'l Weight If Copper Finned Coils, lbs. (kg)	1155 (524)		1155 (524)		1155 (524)		1155 (524)	
COMPRESSORS								
Type	Trio Scrolls		Trio Scrolls		Trio Scrolls		Trio Scrolls	
Nominal tonnage of each Compressor	15.0	20.0	20.0	20.0	20.0	25.0	25.0	25.0
Number Of Compressors per Circuit	3	3	3	3	3	3	3	3
Oil Charge Per Compressor, oz.	140	148	148	148	148	200	200	200
Oil Charge Per Compressor, (g)	(496)	(525)	(525)	(525)	(525)	(709)	(709)	(709)
CAPACITY REDUCTION STEPS - PERCENT OF COMPRESSOR DISPLACEMENT								
Staging, 6 Stages, Circuit #1 in Lead	0-14-33-48-67-81-100		0-17-33-50-67-83-100		0-15-33-48-67-81-100		0-17-33-50-67-83-100	
Staging, 6 Stages, Circuit #2 in Lead	0-19-33-52-67-86-100		0-17-33-50-67-83-100		0-19-33-52-67-86-100		0-17-33-50-67-83-100	
CONDENSERS - HIGH EFFICIENCY FIN AND TUBE TYPE WITH INTEGRAL SUBCOOLING								
Coil Face Area, sq. ft.	105.3	105.3	105.3	105.3	105.3	105.3	105.3	105.3
Coil Face Area, (m ²)	9.8	9.8	9.8	9.8	9.8	9.8	9.8	9.8
Finned Height x Finned Length, in.	50 x151.6	50 x151.6	50 x151.6	50 x151.6	50 x151.6	50 x151.6	50 x151.6	50 x151.6
Finned Height x Finned Length, (mm)	1270 x 3851	1270 x 3851	1270 x 3851	1270 x 3851	1270 x 3851	1270 x 3851	1270 x 3851	1270 x 3851
Fins Per Inch x Rows Deep	16 x 3	16 x 3	16 x 3	16 x 3	16 x 3	16 x 3	16 x 3	16 x 3
Pumpdown Capacity, 90% Full Lbs. (kg)	196 (89)	196 (89)	196 (89)	196 (89)	196 (89)	196 (89)	196 (89)	196 (89)
Maximum Relief Valve Pressure Setting, psig (kPa)	450 (3103)	450 (3103)	450 (3103)	450 (3103)	450 (3103)	450 (3103)	450 (3103)	450 (3103)
CONDENSER FANS - DIRECT DRIVE PROPELLER TYPE								
Number Of Fans - Fan Diameter, in. (mm)	8 – 30 (762)		8 – 30 (762)		8 – 30 (762)		8 – 30 (762)	
Number Of Motors - HP (kW)	8 – 2.0		8 – 2.0		8 – 2.0		8 – 2.0	
Fan And Motor RPM, 60Hz	1140		1140		1140		1140	
60 Hz Fan Tip Speed, FPM (m/sec)	8950 (4224)		8950 (4224)		8950 (4224)		8950 (4224)	
60 Hz Total Unit Airflow, CFM (m ³ /sec)	86,904 (41,020)		86,904 (41,020)		86,904 (41,020)		86,904 (41,020)	
EVAPORATOR - SHELL AND TUBE								
Number of Evaporators	1		1		1		1,	
Number of Refrigerant Circuits	2		2		2		2	
Diameter, in. - Length, ft.	12.8 x 7.9		12.8 x 7.9		14.0 x 8.0		14.0 x 8.0	
Diameter, (mm) – Length, (mm)	324 x 2408		324 x 2408		356 x 2438		356 x 2438	
Water Volume, Gallons, (L)	34 (127)		34 (127)		40 (150)		40 (150)	
Maximum Water Pressure, psig (kPa)	152 (1047)		152 (1047)		152 (1047)		152 (1047)	
Maximum Refrigerant Working Pressure, psig (kPa)	300 (2066)		300 (2066)		300 (2066)		300 (2066)	
Water Inlet / Outlet Victaulic Connections, in. (mm)	5 (127)		5 (127)		5 (127)		5 (127)	
Drain - NPT int, in. (mm)	0.5 (12.7)		0.5 (12.7)		0.5 (12.7)		0.5 (12.7)	
Vent - NPT int, in. (mm)	0.5 (12.7)		0.5 (12.7)		0.5 (12.7)		0.5 (12.7)	

NOTE: Nominal capacity based on 95°F ambient air and 54°F/44°F water range.

AGZ-M, Remote Evaporator

Table 50, Physical Data, Remote Evaporator, AGZ 010AM through 017AM

PHYSICAL DATA	AGZ MODEL NUMBER		
	010A	013A	017A
BASIC DATA			
Unit Capacity @ ARI Conditions (1), Tons (kW)	9.8 (34.3)	13.3 (46.6)	15.9 (55.7)
Number Of Refrigerant Circuits	1	1	1
Unit Operating Charge, R-22, Lb. (kg)	13 (5.9)	14 (5.3)	17 (7.7)
Cabinet Dimensions, LxWxH, In.	73.6 x 46.3 x 49.0	73.6 x 46.3 x 49.0	73.6 x 46.3 x 49.0
Cabinet Dimensions, LxWxH, (mm)	(1869 x 1176 x 1245)	(1869 x 1176 x 1245)	(1869 x 1176 x 1245)
Unit Operating Weight, Lb. (kg)	950 (431)	1276 (579)	1278 (580)
Unit Shipping Weight, Lb. (kg)	1025 (465)	1350 (613)	1363 (619)
Add'l Weight If Copper Finned Coils, Lb. (kg)	220 (99.7)	220 (99.7)	220 (99.7)
COMPRESSORS			
Type	Scroll	Scroll	Scroll
Nominal Tons Per Compressor	6.0 / 6.0	7.5 / 7.5	9.0 / 9.0
Oil Charge Per Compressor, Oz. (g)	60 (1701)	140 (3969)	140 (3969)
CAPACITY REDUCTION STEPS - PERCENT OF COMPRESSOR DSPLACEMENT			
Standard Staging	0 – 50 – 100	0 – 50 – 100	0 – 50 – 100
CONDENSERS - HIGH EFFICIENCY FIN AND TUBE TYPE WITH INTEGRAL SUBCOOLING			
Coil Face Area Sq. Ft. (M ²)	30.3 (2.8)	30.3 (2.8)	30.3 (2.8)
Finned Height x Finned Length, In.	84 x 52	84 x 52	84 x 52
Finned Height x Finned Length, (mm)	(2134) x (1321)	(2134) x (1321)	(2134) x (1321)
Fins Per Inch x Rows Deep	16 x 2	16 x 3	16 x 3
Pumpdown Capacity Lb. (kg)	35.3 (16.0)	50.3 (22.8)	50.3 (22.8)
CONDENSER FANS - DIRECT DRIVE PROPELLER TYPE			
Number Of Fans - Fan Diameter, In. (mm)	2 – 26 (660)	2 – 26 (660)	2 – 26 (660)
Number Of Motors - HP (kW)	2 – 1.0 (0.75)	2 – 1.0 (0.75)	2 – 1.0 (0.75)
Fan And Motor RPM, 60	1140	1140	1140
60 Hz Total Unit Airflow, CFM (l/s)	13950 (6584)	12000 (5664)	12000 (5664)
REMOTE DIRECT EXPANSION EVAPORATOR - BRAZED PLATE-TO-PLATE			
Water Connection Size Victaulic, In. (mm)	2 (51)	2 (51)	2 (51)
Water Volume, Gallons (L)	.94 (3.6)	1.66 (6.3)	2.00 (7.6)
Liquid Line Conn. Braze, inches	1.125	1.125	1.125
Suction Line Conn. Braze, Inches	2.125	2.125	2.125
Temperature Sensor Conn. NPT, Inches	0.75	0.75	0.75
Dry Weight, lbs (kg)	50 (22)	75 (34)	87 (39)
Operating Weight, lbs (kg)	58 (26)	88 (40)	109 (49)
Maximum Refrigerant Working Pressure, psig (kPa)	450 (3103)	450 (3103)	450 (3103)
Maximum Water Pressure, psig (kPa)	450 (3103)	450 (3103)	450 (3103)
Vent and Drain Conn.	Field	Field	Field

NOTE: Nominal capacity based on 95°F ambient air temperature and 54°F/44°F water range with no line loss.

Table 51, Physical Data, Remote Evaporator, AGZ 020AM through 034AM

PHYSICAL DATA	AGZ MODEL NUMBER			
	020A	025A	029A	034A
BASIC DATA				
Unit Capacity @ ARI Conditions (1), Tons (kW)	20.4 (71.4)	22.7 (79.5)	28.3 (99.3)	34.0 (119.0)
Number Of Refrigerant Circuits	1	1	1	1
Unit Operating Charge, R-22, Lb. (kg)	19 (8.6)	19 (8.6)	31 (14.1)	32 (14.5)
Cabinet Dimensions, LxWxH, In.	106.2x 46.3 x 49.0	106.2x 46.3 x 49.0	106.2x 46.3 x 57.0	106.2x 46.3 x 57.0
Cabinet Dimensions, LxWxH, (mm)	(2697 x 1176 x 1245)	(2697 x 1176 x 1245)	(2697 x 1176 x 1248)	(2697 x 1176 x 1248)
Unit Operating Weight, Lbs. (kg)	1459 (662)	1478 (671)	1622 (737)	1817 (825)
Unit Shipping Weight, Lbs. (kg)	1558 (707)	1576 (716)	1719 (780)	1914 (869)
Add'l Weight If Copper Finned Coils, Lb. (kg)	350 (159)	350 (159)	435 (197)	435 (197)
COMPRESSORS				
Type	Scroll	Scroll	Scroll	Scroll
Nominal Horsepower	10.0 / 13.0	13.0 / 13.0	15.0 / 15.0	20.0 / 20.0
Oil Charge Per Compressor, Oz. (g)	140 (3969)	140 (3969)	140 (3969)	296 (8392)
CAPACITY REDUCTION STEPS - PERCENT OF COMPRESSOR DISPLACEMENT				
Standard Staging	0 – 45 - 100	0 – 50 – 100	0 – 50 – 100	0 – 50 – 100
CONDENSERS - HIGH EFFICIENCY FIN AND TUBE TYPE WITH INTEGRAL SUBCOOLING				
Coil Face Area Sq. Ft. (M ²)	49.0 (4.6)	49.0 (4.6)	58.3 (5.4)	58.3 (5.4)
Finned Height x Finned Length, In.	84 x 84	84 x 84	100 x 84	100 x 84
Finned Height x Finned Length, (mm)	(2134) x (2134)	(2134) x (2134)	(2545) x (2134)	(2545) x (2134)
Fins Per Inch x Rows Deep	16 x 2	16 x 2	16 x 3	16 x 3
Pumpdown Capacity lb. (kg)	53.1 (24.0)	53.1 (24.0)	90.7 (41.1)	92.8 (42.0)
CONDENSER FANS - DIRECT DRIVE PROPELLER TYPE				
Number Of Fans - Fan Diameter, In. (mm)	3 – 26 (660)	3 – 26 (660)	3 – 26 (660)	3 – 26 (660)
Number Of Motors - HP (kW)	3 – 1.0 (0.75)	3 – 1.0 (0.75)	3 – 1.0 (0.75)	3 – 1.0 (0.75)
Fan And Motor RPM, 60	1140	1140	1140	1140
60 Hz Total Unit Airflow, CFM (l/s)	20925 (9877)	20925 (9877)	19800 (9346)	19800 (9346)
REMOTE DIRECT EXPANSION EVAPORATOR - BRAZED PLATE-TO-PLATE				
Connection Size Victaulic, In. (mm)	2 (51)	2 (51)	2 (51)	2 (51)
Water Volume, Gallons (L)	2.16 (8.2)	3.05 (11.5)	4.00 (15.1)	5.55 (21.0)
Liquid Line Conn. Braze, inches	1.125	1.125	1.375	1.375
Suction Line Conn. Braze, Inches	2.125	2.125	2.125	2.125
Temperature Sensor Conn. NPT, Inches	0.75	0.75	0.75	0.75
Dry Weight, lbs (kg)	92 (42)	124 (56)	156 (71)	211 (96)
Operating Weight, lbs (kg)	110 (50)	148 (67)	188 (85)	255 (116)
Max. Refrigerant Working Pressure, psig (kPa)	450 (3103)	450 (3103)	450 (3103)	450 (3103)
Maximum Water Pressure, psig (kPa)	350 (2413)	350 (2413)	350 (2413)	350 (2413)
Drain and Vent Connections	Field	Field	Field	Field

NOTE: Nominal capacity based on 95°F ambient air temperature and 54°F/44°F water range with no line losses.

Table 52, Physical Data, Remote Evaporator, AGZ 026BM through 035BM

PHYSICAL DATA	AGZ MODEL NUMBER					
	026B		030B		035B	
BASIC DATA	Ckt.1	Ckt.2	Ckt.1	Ckt.2	Ckt.1	Ckt.2
Unit Capacity @ ARI (1), Tons (kW)	27.2 (95.4)		30.2 (106.3)		33.2 (117.2)	
Number Of Refrigerant Circuits	2		2		2	
Outdoor Unit Operating Charge, R-22, Lbs.	23	23	25	25	28	28
Outdoor Unit Operating Charge, R-22, (kg)	(10.4)	(10.4)	(11.3)	(11.3)	(12.7)	(12.7)
Cabinet Dimensions, LxWxH, In.	94.4 x 88.0 x 100.4		94.4 x 88.0 x 100.4		94.4 x 88.0 x 100.4	
Cabinet Dimensions, LxWxH, (mm)	(2398 x 2235 x 2550)		(2398 x 2235 x 2550)		(2398 x 2235 x 2550)	
Unit Operating Weight, Lb (kg)	3600 (1634)		3600 (1634)		3600 (1634)	
Unit Shipping Weight, Lb (kg)	3550 (1612)		3550 (1612)		3550 (1612)	
Add'l Weight If Copper Finned Coils, Lb (kg)	284 (129)		284 (129)		284 (129)	
COMPRESSORS						
Type	Tandem Scrolls		Tandem Scrolls		Tandem Scrolls	
Nominal tonnage of each Compressor	7.5	7.5	7.5	9.0	9.0	9.0
Number Of Compressors per Circuit	2	2	2	2	2	2
Oil Charge Per Compressor, Oz.	140	140	140	140	140	140
Oil Charge Per Compressor, (g)	(496)	(496)	(496)	(496)	(496)	(496)
CAPACITY REDUCTION STEPS - PERCENT OF COMPRESSOR DISPLACEMENT						
Staging, 4 Stages, Circuit #1 in Lead	0-25-50-75-100		0-23-50-73-100		0-25-50-75-100	
Staging, 4 Stages, Circuit #2 in Lead	0-25-50-75-100		0-27-50-77-100		0-25-50-75-100	
CONDENSERS - HIGH EFFICIENCY FIN AND TUBE TYPE WITH INTEGRAL SUBCOOLING						
Coil Face Area, Sq. Ft.	26.3	26.3	26.3	26.3	26.3	26.3
Coil Face Area, (M ²)	2.4	2.4	2.4	2.4	2.4	2.4
Finned Height x Finned Length, In.	50x75.6	50x75.6	50x75.6	50x75.6	50x75.6	50x75.6
Finned Height x Finned Length, (mm)	1270 x 1920	1270 x 1920	1270 x 1920	1270 x 1920	1270 x 1920	1270 x 1920
Fins Per Inch x Rows Deep	16 x 3	16 x 3	16 x 3	16 x 3	16 x 3	16 x 3
Pumpdown Capacity, 90% Full Lbs. (kg)	49 (22)	49 (22)	49 (22)	49 (22)	49 (22)	49 (22)
Maximum Relief Valve Pressure Setting, psig (kPa)	450 (3103)	450 (3103)	450 (3103)	450 (3103)	450 (3103)	450 (3103)
CONDENSER FANS - DIRECT DRIVE PROPELLER TYPE						
Number Of Fans - Fan Diameter, In. (mm)	4 – 30 (762)		4 – 30 (762)		4 – 30 (762)	
Number Of Motors - HP (kW) (2)	4 – 1.0		4 – 1.0		4 – 1.0	
Fan And Motor RPM, 60Hz	1140		1140		1140	
60 Hz Fan Tip Speed, FPM (M/Sec)	8950 (4224)		8950 (4224)		8950 (4224)	
60 Hz Total Unit Airflow, CFM (M ³ /sec)	24,316 (11,478)		24,316 (11,478)		24,316 (11,478)	
REMOTE EVAPORATOR - BRAZED PLATE-TO-PLATE						
Number of Evaporators	1		1		1	
Number of Refrigerant Circuits	2		2		2	
Water Inlet / Outlet Victaulic Conn. in. (mm)	3 (76)		3 (76)		3 (76)	
Liquid Line Conn. Braze, Inches	(2) 1.375		(2) 1.375		(2) 1.375	
Suction Line Conn., Braze, Inches	(2) 2.125		(2) 2.125		(2) 2.125	
Temperature Sensor Conn. NPT	0.75		0.75		0.75	
Shipping Wt. Lb (kg)	343 (155)		376 (170)		409 (185)	
Operating Wt. Lb. (kg)	377 (171)		416 (188)		455 (206)	
Water Volume, Gallons, (L)	4.3 (16.4)		5.0 (18.9)		5.7 (21.4)	
Maximum Water Pressure, psig (kPa)	363 (2503)		363 (2503)		363 (2503)	
Max. Refrig. Working Pressure, psig (kPa)	450 (3102)		450 (3102)		450 (3102)	
Drain and Vent	Field		Field		Field	

NOTES:

- Nominal capacity based on 95°F ambient air and 54°F/44°F water range without piping loss.
- Except for 380V/60 & 575V/60, HP = 2.0

Table 53, Physical Data, Remote Evaporator, AGZ 040BM through 055BM

PHYSICAL DATA	AGZ MODEL NUMBER							
	040B		045B		050B		055B	
BASIC DATA	Ckt.1	Ckt.1	Ckt.2	Ckt.1	Ckt.2	Ckt.1	Ckt.2	Ckt.2
Unit Capacity @ ARI Conditions (1), Tons (kW)	38.5 (135.5)		42.5 (149.6)		47.0 (165.4)		52.2 (183.7)	
Number Of Refrigerant Circuits	2		2		2		2	
Outdoor Unit Operating Charge, R-22, lbs.	32	32	33	33	35	35	44	44
Outdoor Unit Operating Charge, R-22, (kg)	(14.6)	(14.6)	(15.0)	(15.0)	(15.9)	(15.9)	(20.0)	(20.0)
Cabinet Dimensions, LxWxH, in.	94.4 x 88.0 x 100.4		94.4 x 88.0 x 100.4		94.4 x 88.0 x 100.4		94.4 x 88.0 x 100.4	
Cabinet Dimensions, LxWxH, (mm)	(2398 x 2235 x 2250)		(2398 x 2235 x 2250)		(2398 x 2235 x 2250)		(2398 x 2235 x 2250)	
Unit Operating Weight, Lbs. (kg)	3610 (1639)		3650 (1657)		3800 (1725)		3850 (1748)	
Unit Shipping Weight, Lbs. (kg)	3550 (1612)		3590 (1630)		3730 (1693)		3780 (1716)	
Add'l Weight If Copper Finned Coils, lbs. (kg)	288 (130)		288 (130)		476 (130)		476 (130)	
COMPRESSORS								
Type	Tandem Scrolls		Tandem Scrolls		Tandem Scrolls		Tandem Scrolls	
Nominal tonnage of each Compressor	10.0	10.0	10.0	13.0	13.0	13.0	13.0	15.0
Number Of Compressors per Circuit	2	2	2	2	2	2	2	2
Oil Charge Per Compressor, oz.	140	140	140	140	140	140	140	140
Oil Charge Per Compressor, (g)	(496)	(496)	(496)	(496)	(496)	(496)	(496)	(496)
CAPACITY REDUCTION STEPS - PERCENT OF COMPRESSOR DISPLACEMENT								
Staging, 4 Stages, Circuit #1 in Lead	0-25-50-75-100		0-22-50-46-100		0-25-50-75-100		0-25-50-75-100	
Staging, 4 Stages, Circuit #2 in Lead	0-25-50-75-100		0-28-50-85-100		0-25-50-75-100		0-25-50-75-100	
CONDENSERS - HIGH EFFICIENCY FIN AND TUBE TYPE WITH INTEGRAL SUBCOOLING								
Coil Face Area, sq. ft.	44.1	44.1	44.1	44.1	44.1	44.1	44.1	44.1
Coil Face Area (sq. M)	4.1	4.1	4.1	4.1	4.1	4.1	4.1	4.1
Finned Height x Finned Length, in.	42x75.6	42x75.6	42x75.6	42x75.6	42x75.6	42x75.6	42x75.6	42x75.6
Finned Height x Finned Length, (mm)	1067 x 1920	1067 x 1920	1067 x 1920	1067 x 1920	1067 x 1920	1067 x 1920	1067 x 1920	1067 x 1920
Fins Per Inch x Rows Deep	16 x 2	16 x 2	16 x 2	16 x 2	16 x 3	16 x 3	16 x 3	16 x 3
Pumpdown Capacity, 90% Full Lbs. (kg)	60 (27)	60 (27)	60(27)	60(27)	82 (37)	82 (37)	82 (37)	82 (37)
Maximum Relief Valve Pressure Setting, psig (kPa)	450 (3103)	450 (3103)	450 (3103)	450 (3103)	450 (3103)	450 (3103)	450 (3103)	450 (3103)
CONDENSER FANS - DIRECT DRIVE PROPELLER TYPE								
Number Of Fans - Fan Diameter, in. (mm)	4 – 30 (762)		4 – 30 (762)		4 – 30 (762)		4 – 30 (762)	
Number Of Motors - HP (kW) (2)	4 – 1.5		4 – 1.5		4 – 1.5		4 – 1.5	
Fan And Motor RPM, 60Hz	1140		1140		1140		1140	
60 Hz Fan Tip Speed, FPM (m/sec)	8950 (4224)		8950 (4224)		8950 (4224)		8950 (4224)	
60 Hz Total Unit Airflow, CFM (m ³ /sec)	39,600 (18,692)		39,600 (18,692)		39,600 (18,692)		39,600 (18,692)	
REMOTE EVAPORATOR - BRAZED PLATE-TO-PLATE								
Number of Evaporators	1		1		1		1	
Number of Refrigerant Circuits	2		2		2		2	
Water Inlet / Outlet Victaulic Conn. in. (mm)	3 (76)		3 (76)		3 (76)		3 (76)	
Liquid Line Conn. Braze, Inches	(2) 1.375		(2) 1.375		(2) 1.375		(2) 1.375	
Suction Line Conn., Braze, Inches	(2) 2.125		(2) 2.125		(2) 2.625		(2) 2.625	
Temperature Sensor Conn. NPT	0.75		0.75		0.75		0.75	
Shipping Wt. Lb (kg)	443 (201)		487 (221)		532 (242)		587 (266)	
Operating Wt. Lb, (kg)	493 (224)		545 (247)		597 (271)		661 (300)	
Water Volume, Gallons, (L)	6.3 (23.9)		7.2 (27.3)		8.1 (30.7)		9.2 (34.9)	
Maximum Water Pressure, psig (kPa)	363 (2503)		363 (2503)		363 (2503)		363 (2503)	
Max. Refrig. Working Pressure, psig (kPa)	450 (3102)		450 (3102)		450 (3102)		450 (3102)	
Drain and Vent	Field		Field		Field		Field	

NOTES:

1. Nominal capacity based on 95°F ambient air and 54°F/44°F water range without piping loss.
2. Except for 380V/60 & 575V/60, HP = 2.0

Table 54, Physical Data, Remote Evaporator, AGZ 060BM through 070BM

PHYSICAL DATA	AGZ MODEL NUMBER					
	060B		065B		070B	
BASIC DATA	Ckt.1	Ckt.2	Ckt.1	Ckt.2	Ckt.1	Ckt.2
Unit Capacity @ ARI Conditions (1), Tons (kW)	57.1 (201.0)		61.4 (215.5)		65.5 (230.0)	
Number Of Refrigerant Circuits	2		2		2	
Unit Operating Charge, R-22, lbs.	48	48	51	51	54	54
Unit Operating Charge, R-22, (kg)	(21.8)	(21.8)	(23.1)	(23.1)	(24.5)	(24.5)
Cabinet Dimensions, LxWxH, in.	94.4 x 88.0 x 100.4		94.4 x 88.0 x 100.4		94.4 x 88.0 x 100.4	
Cabinet Dimensions, LxWxH, (mm)	(2398 x 2235 x 2550)		(2398 x 2235 x 2550)		(2398 x 2235 x 2550)	
Outdoor Unit Operating Weight, Lbs. (kg)	4040 (1834)		4070 (1848)		4180 (1898)	
Outdoor Unit Shipping Weight, Lbs. (kg)	3820 (1734)		3970 (1802)		4080 (1852)	
Add'l Weight If Copper Finned Coils, lbs. (kg)	476 (216)		568 (258)		568 (258)	
COMPRESSORS						
Type	Tandem Scrolls		Tandem Scrolls		Tandem Scrolls	
Nominal tonnage of each Compressor	15.0	15.0	15.0	15 / 20	15 / 20	15 / 20
Number Of Compressors per Circuit	2	2	2	2	2	2
Oil Charge Per Compressor, oz.	140	140	140	140 /148	140 /148	140 /148
Oil Charge Per Compressor, (g)	496	496	496	496/ 525	496/ 525	496/ 525
CAPACITY REDUCTION STEPS - PERCENT OF COMPRESSOR DISPLACEMENT						
Staging, 4 Stages, Circuit #1 in Lead	0-25-50-75-100		0-23-46-77-100		0-25-50-75-100	
Staging, 4 Stages, Circuit #2 in Lead	0-25-50-75-100		0-31-46-69-100		0-25-50-75-100	
CONDENSERS - HIGH EFFICIENCY FIN AND TUBE TYPE WITH INTEGRAL SUBCOOLING						
Coil Face Area, sq. ft.	44.1	44.1	52.6	52.6	52.6	52.6
Coil Face Area, (m ²)	4.1	4.1	4.9	4.9	4.9	4.9
Finned Height x Finned Length, in.	42x75.6	42x75.6	100x75.6	100x75.6	100x75.6	100x75.6
Finned Height x Finned Length, (mm)	1067 x 1920	1067 x 1920	2540 x 1920	2540 x 1920	2540 x 1920	2540 x 1920
Fins Per Inch x Rows Deep	16 x 3	16 x 3	16 x 3	16 x 3	16 x 3	16 x 3
Pumpdown Capacity, 90% Full Lbs. (kg)	82 (37)	82 (37)	98 (44)	98 (44)	98 (44)	98 (44)
Maximum Relief Valve Pressure Setting, psig (kPa)	450 (3103)	450 (3103)	450 (3103)	450 (3103)	450 (3103)	450 (3103)
CONDENSER FANS - DIRECT DRIVE PROPELLER TYPE						
Number Of Fans - Fan Diameter, in. (mm)	4 – 30 (762)		4 – 30 (762)		4 – 30 (762)	
Number Of Motors - HP (kW) (2)	4 – 1.5		4 – 2.0		4 – 2.0	
Fan And Motor RPM, 60Hz	1140		1140		1140	
60 Hz Fan Tip Speed, FPM (m/sec)	8950 (4224)		8950 (4224)		8950 (4224)	
60 Hz Total Unit Airflow, CFM (m ³ /sec)	37,228 (17,572)		43,452 (20,510)		43,452 (20,510)	
REMOTE EVAPORATOR - BRAZED PLATE-TO-PLATE						
Number of Evaporators	1		1		1	
Number of Refrigerant Circuits	2		2		2	
Water Inlet / Outlet Victaulic Conn. in. (mm)	3 (76)		3 (76)		3 (76)	
Liquid Line Conn. Braze, Inches	(2) 1.375		(2) 1.375		(2) 1.375	
Suction Line Conn., Braze, Inches	(2) 2.625		(2) 2.625		(2) 2.625	
Temperature Sensor Conn. NPT	0.75		0.75		0.75	
Shipping Wt. Lb (kg)	587 (266)		687 (312)		687 (312)	
Operating Wt. Lb, (kg)	661 (300)		777 (353)		777 (353)	
Water Volume, Gallons, (L)	9.2 (34.9)		11.2 (42.4)		11.2 (42.4)	
Maximum Water Pressure, psig (kPa)	363 (2503)		363 (2503)		363 (2503)	
Max. Refrig. Working Pressure, psig (kPa)	450 (3102)		450 (3102)		450 (3102)	
Drain and Vent	Field		Field		Field	

NOTES:

1. Nominal capacity based on 95°F ambient air and 54°F/44°F water range without piping loss.
2. Except for 380V/60 & 575V/60, HP = 2.0

Table 55, Physical Data, Remote Evaporator, AGZ 075BM through 090BM

PHYSICAL DATA	AGZ MODEL NUMBER					
	075B		085B		090B	
BASIC DATA	Ckt.1	Ckt.2	Ckt.1	Ckt.2	Ckt.1	Ckt.2
Unit Capacity @ ARI Conditions (1), Tons (kW)	73.7 (259.4)		79.6 (280.2)		85.5 (301.0)	
Number Of Refrigerant Circuits	2		2		2	
Unit Operating Charge, R-22, lbs.	57	57	62	62	67	67
Unit Operating Charge, R-22, (kg)	(25.9)	(25.9)	(28.2)	(28.1)	(30.4)	(30.4)
Cabinet Dimensions, LxWxH, in.	134.9 x 88.0 x 100.4		134.9 x 88.0 x 100.4		134.9 x 88.0 x 100.4	
Cabinet Dimensions, LxWxH, (mm)	(3426 x 2235 x 2550)		(3426 x 2235 x 2550)		(3426 x 2235 x 2550)	
Outdoor Unit Operating Weight, Lbs. (kg)	5630 (2556)		5790 (2629)		5950 (2701)	
Outdoor Unit Shipping Weight, Lbs. (kg)	5510 (2502)		5670 (2574)		5830 (2647)	
Add'l Weight If Copper Finned Coils, lbs. (kg)	870 (395)		870 (395)		870 (395)	
COMPRESSORS						
Type	Tandem Scrolls		Tandem Scrolls		Tandem Scrolls	
Nominal tonnage of each Compressor	20.0	20.0	20.0	25.0	25.0	25.0
Number Of Compressors per Circuit	2	2	2	2	2	2
Oil Charge Per Compressor, oz.	148	148	148	200	200	200
Oil Charge Per Compressor, (g)	(525)	(525)	(525)	(709)	(709)	(709)
CAPACITY REDUCTION STEPS - PERCENT OF COMPRESSOR DISPLACEMENT						
Staging, 4 Stages, Circuit #1 in Lead	0-25-50-75-100		0-22-50-72-100		0-25-50-75-100	
Staging, 4 Stages, Circuit #2 in Lead	0-25-50-75-100		0-28-50-78-100		0-25-50-75-100	
CONDENSERS - HIGH EFFICIENCY FIN AND TUBE TYPE WITH INTEGRAL SUBCOOLING						
Coil Face Area, sq. ft.	78.8	78.8	78.8	78.8	78.8	78.8
Coil Face Area, (m ²)	7.3	7.3	7.3	7.3	7.3	7.3
Finned Height x Finned Length, in.	50 x113.4	50 x113.4	50 x113.4	50 x113.4	50 x113.4	50 x113.4
Finned Height x Finned Length, (mm)	1270 x 2880	1270 x 2880	1270 x 2880	1270 x 2880	1270 x 2880	1270 x 2880
Fins Per Inch x Rows Deep	16 x 3	16 x 3	16 x 3	16 x 3	16 x 3	16 x 3
Pumpdown Capacity, 90% Full Lbs. (kg)	147 (67)	147 (67)	147 (67)	147 (67)	147 (67)	147 (67)
Maximum Relief Valve Pressure Setting, psig (kPa)	450 (3103)	450 (3103)	450 (3103)	450 (3103)	450 (3103)	450 (3103)
CONDENSER FANS - DIRECT DRIVE PROPELLER TYPE						
Number Of Fans - Fan Diameter, in. (mm)	6 – 30 (762)		6 – 30 (762)		6 – 30 (762)	
Number Of Motors - HP (kW)	6 – 2.0		6 – 2.0		6 – 2.0	
Fan And Motor RPM, 60Hz	1140		1140		1140	
60 Hz Fan Tip Speed, FPM (m/sec)	8950 (4224)		8950 (4224)		8950 (4224)	
60 Hz Total Unit Airflow, CFM (m ³ /sec)	65,178 (30,765)		65,178 (30,765)		65,178 (30,765)	
REMOTE EVAPORATOR - SHELL AND TUBE						
Number of Evaporators	1		1		1	
Number of Refrigerant Circuits	2		2		2	
Water Inlet / Outlet Victaulic Conn. in. (mm)	5 (127)		5 (127)		5 (127)	
Liquid Line Conn. Braze, Inches	(2) 1.375		(2) 1.375		(2) 1.375	
Suction Line Conn., Braze, Inches	(2) 3.125		(2) 3.125		(2) 3.125	
Temperature Sensor Conn. NPT	0.05		0.05		0.05	
Shipping Wt. Lb (kg)	528 (240)		528 (240)		528 (240)	
Operating Wt. Lb, (kg)	728 (330)		728 (330)		728 (330)	
Water Volume, Gallons, (L)	25 (95)		25 (95)		25 (95)	
Maximum Water Pressure, psig (kPa)	152 (1047)		152 (1047)		152 (1047)	
Max. Refrig. Working Pressure, psig (kPa)	300 (2066)		300 (2066)		300 (2066)	
Drain and Vent, NPTF, in.	0.5 (12.7)		0.5 (12.7)		0.5 (12.7)	

NOTES:

- Nominal capacity based on 95°F ambient air and 54°F/44°F water range without piping loss.
- Except for 380V/60 & 575V/60, HP = 2.0

Table 5, Physical Data, Remote Evaporator, AGZ 100BM through 130BM

PHYSICAL DATA	AGZ MODEL NUMBER							
	100B		110B		120B		130B	
BASIC DATA	Ckt.1	Ckt.2	Ckt.1	Ckt.2	Ckt.1	Ckt.2	Ckt.1	Ckt.2
Unit Capacity @ ARI Conditions (1), Tons (kW)	97.6 (342.6)		107.5 (378.4)		119.8 (421.7)		129.4 (455.5)	
Number Of Refrigerant Circuits	2		2		2		2	
Unit Operating Charge, R-22, lbs.	79	79	84	84	93	93	102	102
Unit Operating Charge, R-22, (kg)	(35.9)	(35.9)	(38.1)	(38.1)	(42.2)	(42.2)	(46.3)	(46.3)
Cabinet Dimensions, LxWxH, in.	173.1 x 88.0 x 100.4		173.1 x 88.0 x 100.4		173.1 x 88.0 x 100.4		173.1 x 88.0 x 100.4	
Cabinet Dimensions, LxWxH, (mm)	(4397 x 2235 x 2550)		(4397 x 2235 x 2550)		(4397 x 2235 x 2550)		(4397 x 2235 x 2550)	
Outdoor Unit Operating Weight, Lbs. (kg)	6970 (3164)		7230 (3282)		7480 (3396)		7760 (3523)	
Outdoor Unit Shipping Weight, Lbs. (kg)	6820 (3096)		7080 (3214)		7360 (3341)		7640 (3469)	
Add'l Weight If Copper Finned Coils, lbs. (kg)	1155 (524)		1155 (524)		1155 (524)		1155 (524)	
COMPRESSORS								
Type	Trio Scrolls		Trio Scrolls		Trio Scrolls		Trio Scrolls	
Nominal tonnage of each Compressor	15.0	20.0	20.0	20.0	20.0	25.0	25.0	25.0
Number Of Compressors per Circuit	3	3	3	3	3	3	3	3
Oil Charge Per Compressor, oz.	140	148	148	148	148	200	200	200
Oil Charge Per Compressor, (g)	(496)	(525)	(525)	(525)	(525)	(709)	(709)	(709)
CAPACITY REDUCTION STEPS - PERCENT OF COMPRESSOR DISPLACEMENT								
Staging, 6 Stages, Circuit #1 in Lead	0-14-33-48-67-81-100		0-17-33-50-67-83-100		0-15-33-48-67-81-100		0-17-33-50-67-83-100	
Staging, 6 Stages, Circuit #2 in Lead	0-19-33-52-67-86-100		0-17-33-50-67-83-100		0-19-33-52-67-86-100		0-17-33-50-67-83-100	
CONDENSERS - HIGH EFFICIENCY FIN AND TUBE TYPE WITH INTEGRAL SUBCOOLING								
Coil Face Area, sq. ft.	105.3	105.3	105.3	105.3	105.3	105.3	105.3	105.3
Coil Face Area, (m ²)	9.8	9.8	9.8	9.8	9.8	9.8	9.8	9.8
Finned Height x Finned Length, in.	50 x151.6	50 x151.6	50 x151.6	50 x151.6	50 x151.6	50 x151.6	50 x151.6	50 x151.6
Finned Height x Finned Length, (mm)	1270 x 3851	1270 x 3851	1270 x 3851	1270 x 3851	1270 x 3851	1270 x 3851	1270 x 3851	1270 x 3851
Fins Per Inch x Rows Deep	16 x 3	16 x 3	16 x 3	16 x 3	16 x 3	16 x 3	16 x 3	16 x 3
Pumpdown Capacity, 90% Full Lbs. (kg)	196 (89)	196 (89)	196 (89)	196 (89)	196 (89)	196 (89)	196 (89)	196 (89)
Maximum Relief Valve Pressure Setting, psig (kPa)	450 (3103)	450 (3103)	450 (3103)	450 (3103)	450 (3103)	450 (3103)	450 (3103)	450 (3103)
CONDENSER FANS - DIRECT DRIVE PROPELLER TYPE								
Number Of Fans - Fan Diameter, in. (mm)	8 – 30 (762)		8 – 30 (762)		8 – 30 (762)		8 – 30 (762)	
Number Of Motors - HP (kW)	8 – 2.0		8 – 2.0		8 – 2.0		8 – 2.0	
Fan And Motor RPM, 60Hz	1140		1140		1140		1140	
60 Hz Fan Tip Speed, FPM (m/sec)	8950 (4224)		8950 (4224)		8950 (4224)		8950 (4224)	
60 Hz Total Unit Airflow, CFM (m ³ /sec)	86,904 (41,020)		86,904 (41,020)		86,904 (41,020)		86,904 (41,020)	
REMOTE EVAPORATOR - SHELL AND TUBE								
Number of Evaporators	1		1		1		1,	
Number of Refrigerant Circuits	2		2		2		2	
Water Inlet / Outlet Victaulic Conn. in. (mm)	5 (127)		5 (127)		8 (203)		8 (203)	
Liquid Line Conn. Braze, Inches	(2) 1.375		(2) 1.375		(2) 1.375		(2) 1.375	
Suction Line Conn., Braze, Inches	(2) 3.125		(2) 3.125		(2) 3.125		(2) 3.125	
Temperature Sensor Conn. NPT	0.50		0.50		0.50		0.50	
Shipping Wt. Lb (kg)	596 (270)		596 (270)		799 (362)		799 (362)	
Operating Wt. Lb, (kg)	868 (393)		868 (393)		1119 (507)		1119 (507)	
Water Volume, Gallons, (L)	34 (127)		34 (127)		40 (150)		40 (150)	
Maximum Water Pressure, psig (kPa)	152 (1047)		152 (1047)		152 (1047)		152 (1047)	
Max. Refrig. Working Pressure, psig (kPa)	300 (2066)		300 (2066)		300 (2066)		300 (2066)	
Drain and Vent, NPTF, in.	0.5 (12.7)		0.5 (12.7)		0.5 (12.7)		0.5 (12.7)	

NOTES:

- Nominal capacity based on 95°F ambient air and 54°F/44°F water range without piping loss.
- Except for 380V/60 & 575V/60, HP = 2.0

Dimensional Data

Figure 12, Dimensions AGZ 010A through 017A Packaged Chiller

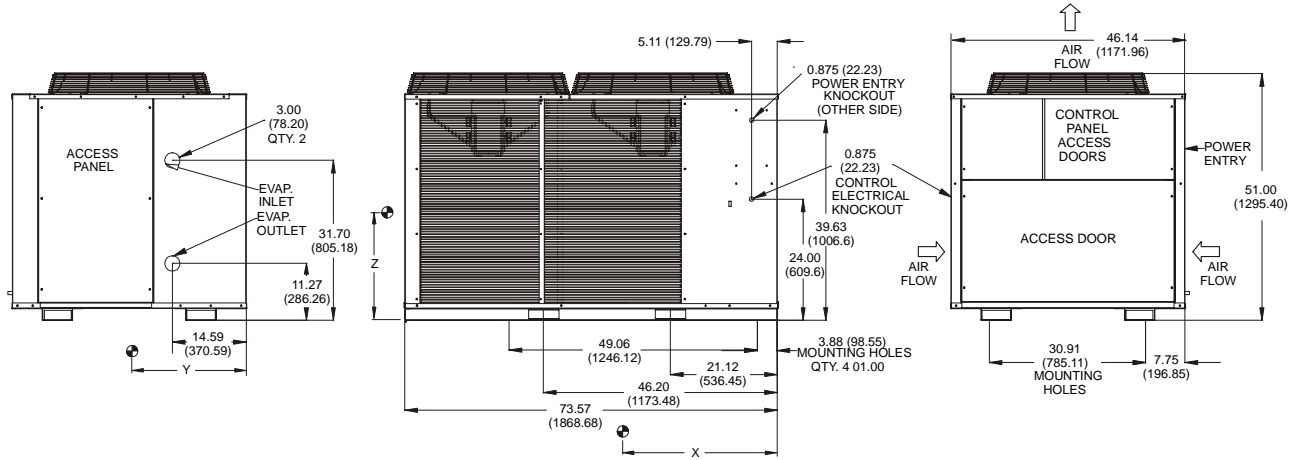

AGZ Unit Size	Center of Gravity Inches (mm)			Evaporator Connection Size Inch Victaulic
	X	Y	Z	
AGZ 010	27.8 (706)	22.7 (576)	19.2 (487)	2
AGZ 013	24.3 (617)	22.5 (571)	19.1 (485)	2
AGZ 017	24.4 (619)	22.4 (568)	19.1 (485)	2

Figure 13, AGZ 020A through 034A

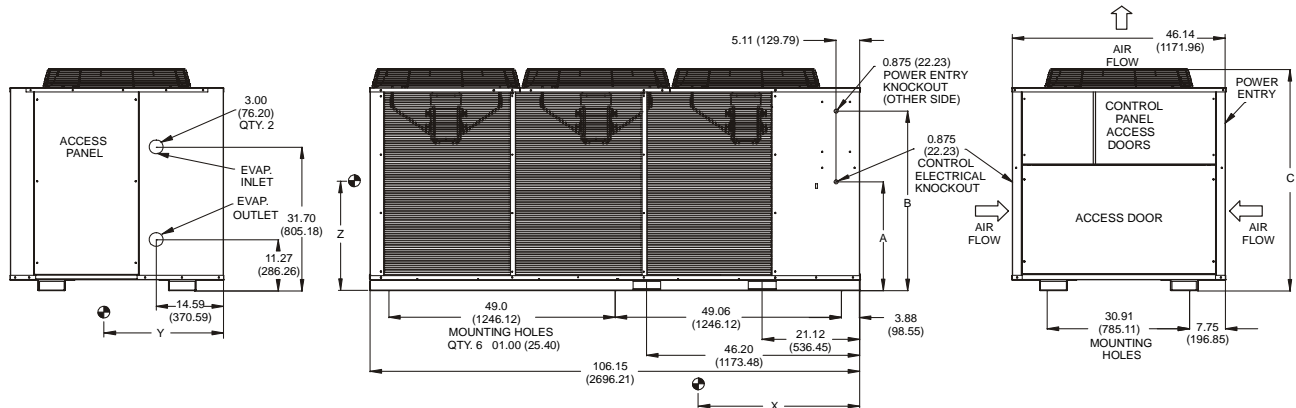

AGZ Unit Size	Dimensions Inches (mm)			Center of Gravity Inches (mm)			Evaporator Connection Size Inch Victaulic
	A	B	C	X	Y	Z	
AGZ 020	24.0 (609)	39.6 (1006)	49.0 (1244)	33.8 (858)	22.4 (568)	20.2 (513)	2
AGZ 025	24.0 (609)	39.6 (1006)	49.0 (1244)	33.7 (855)	22.2 (563)	20.1 (510)	2
AGZ 029	33.0 (838)	47.6 (1209)	57.0 (1447)	36.5 (927)	23.1 (586)	22.6 (574)	2
AGZ 034	33.0 (838)	47.6 (1209)	57.0 (1447)	35.0 (889)	23.1 (58)	21.4 (543)	2

Figure 14, Dimensions, AGZ 026BS/BH – 070BS/BH Packaged Chiller

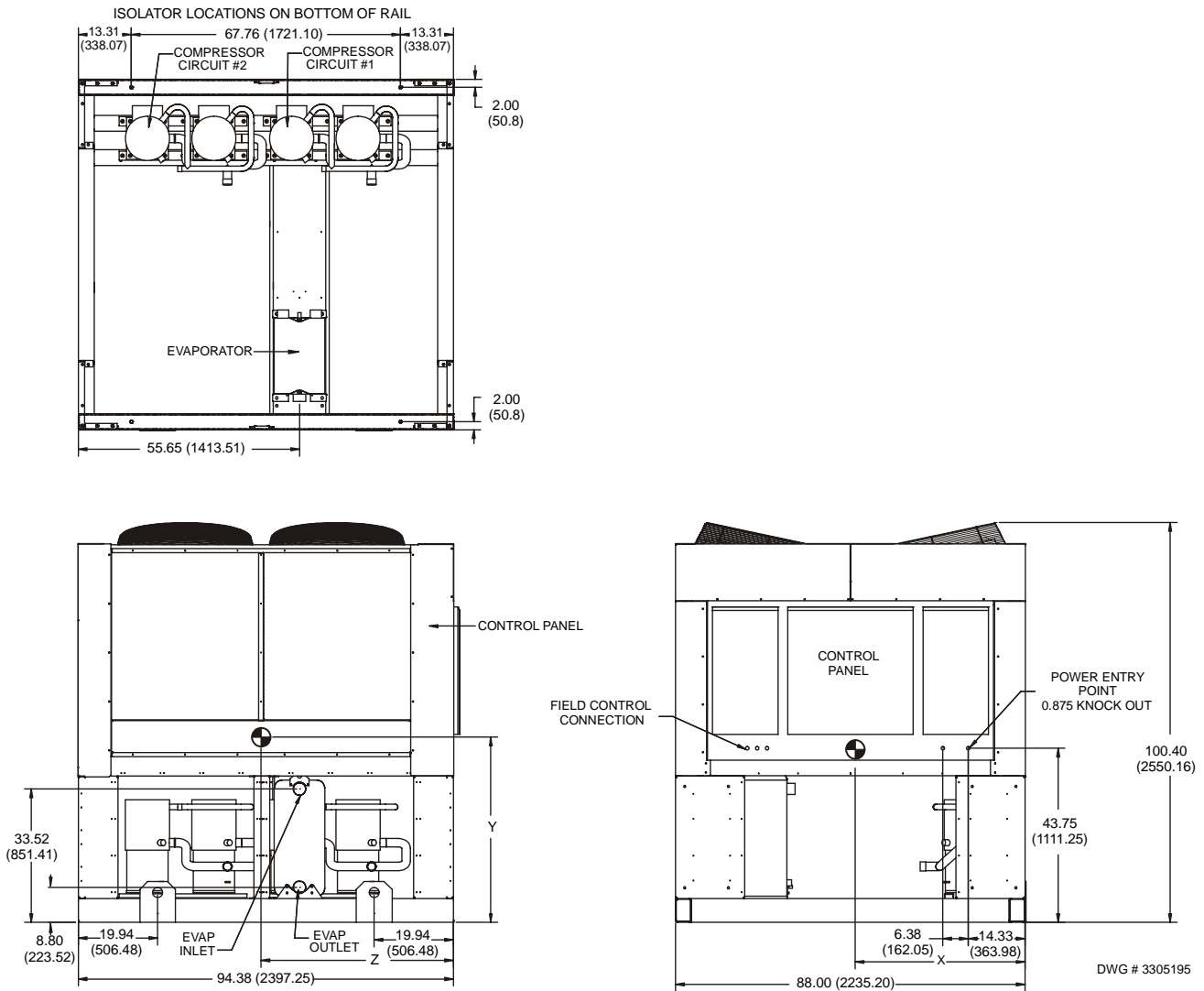

NOTE: Hail and wind guards add 20 inches to the width of each side.

Unit Size	Center of Gravity - Inches (mm)			Evap Inlet & Outlet Victaulic in.	Weights – Lbs (kg)	
	X	Y	Z		Shipping Weight	Operating Weight
AGZ 026BS/BH	39 (991)	40 (1016)	42 (1067)	3	3950 (1792)	3990 (1810)
AGZ 030BS/BH	39 (991)	40 (1016)	42 (1067)	3	3990 (1810)	4040 (1833)
AGZ 035BS/BH	40 (1016)	40 (1016)	42 (1067)	3	4030 (1828)	4080 (1851)
AGZ 040BS/BH	39 (991)	39 (991)	41 (1041)	3	4070 (1846)	4130 (1873)
AGZ 045BS/BH	40 (1016)	38 (965)	41 (1041)	3	4210 (1910)	4270 (1937)
AGZ 050BS/BH	40 (1016)	39 (991)	42 (1067)	3	4330 (1964)	4400 (1996)
AGZ 055BS/BH	40 (1016)	39 (991)	43 (1092)	3	4460 (2023)	4540 (2059)
AGZ 060BS/BH	40 (1016)	39 (991)	43 (1092)	3	4520 (2050)	4600 (2087)
AGZ 065BS/BH	41 (1041)	40 (1016)	45 (1143)	3	4760 (2159)	4860 (2204)
AGZ 070BS/BH	41 (1041)	41 (1041)	45 (1143)	3	4890 (2218)	4990 (2263)

Figure 15, Dimensions, AGZ 075BS/BH - 090BS/BH Packaged Chiller

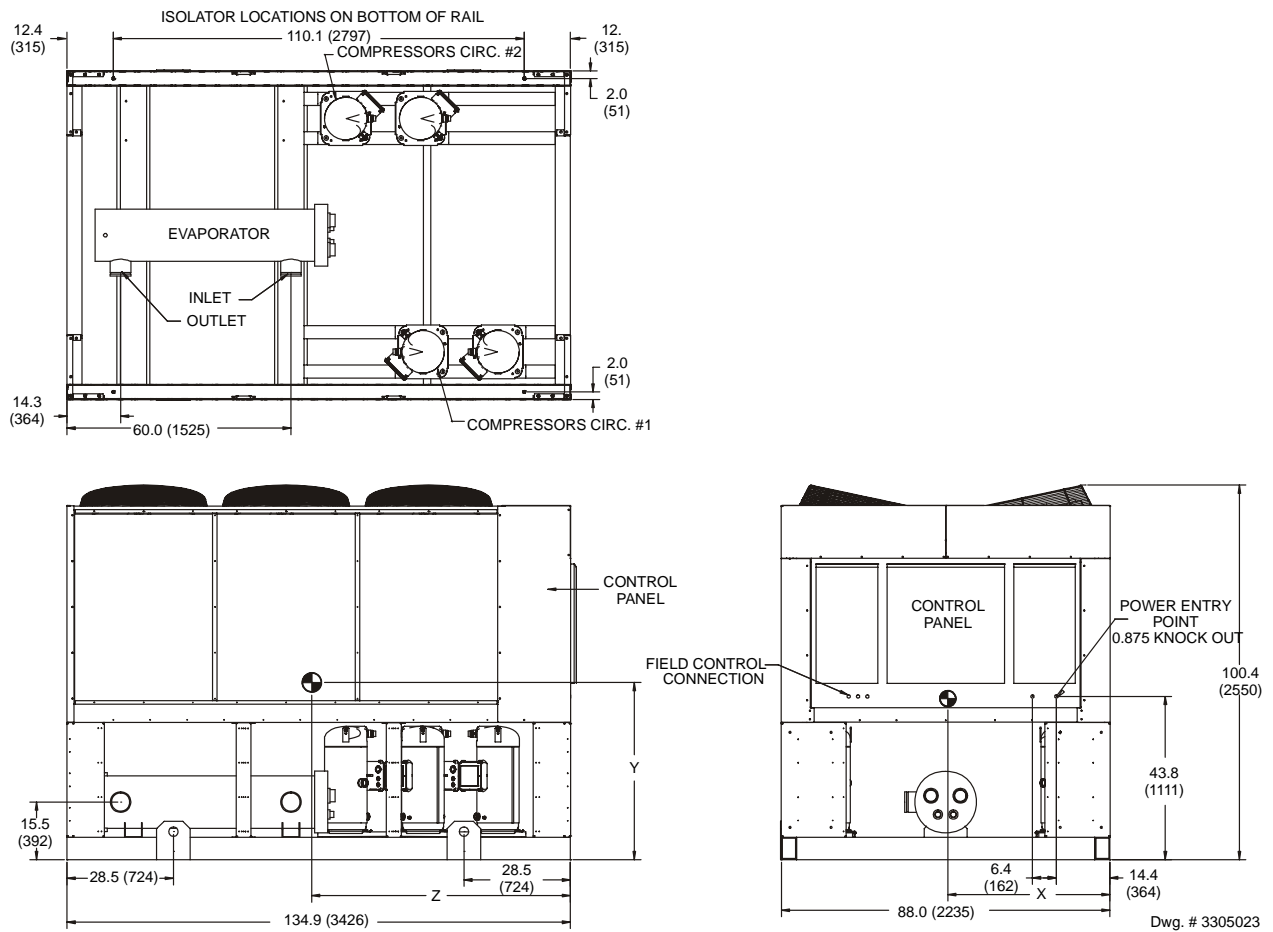

NOTE: Hail and wind guards add 20 inches to the width of each side.

Unit Size	Center of Gravity Inches (mm)			Evap Inlet & Outlet Victaulic in.	Weights Lbs. (kg)	
	X	Y	Z		Shipping Weight	Operating Weight
AGZ 075BS/BH	44 (1118)	42 (1067)	60 (1524)	5	6320 (2867)	6530 (2962)
AGZ 085BS/BH	43 (1092)	40 (1016)	60 (1524)	5	6480 (2939)	6690 (3035)
AGZ 090BS/BH	44 (1118)	39 (991)	59 (1499)	5	6640 (3012)	6850 (3107)

Figure 16, Dimensions, AGZ 100BS/BH - 130BS/BH Packaged Chiller

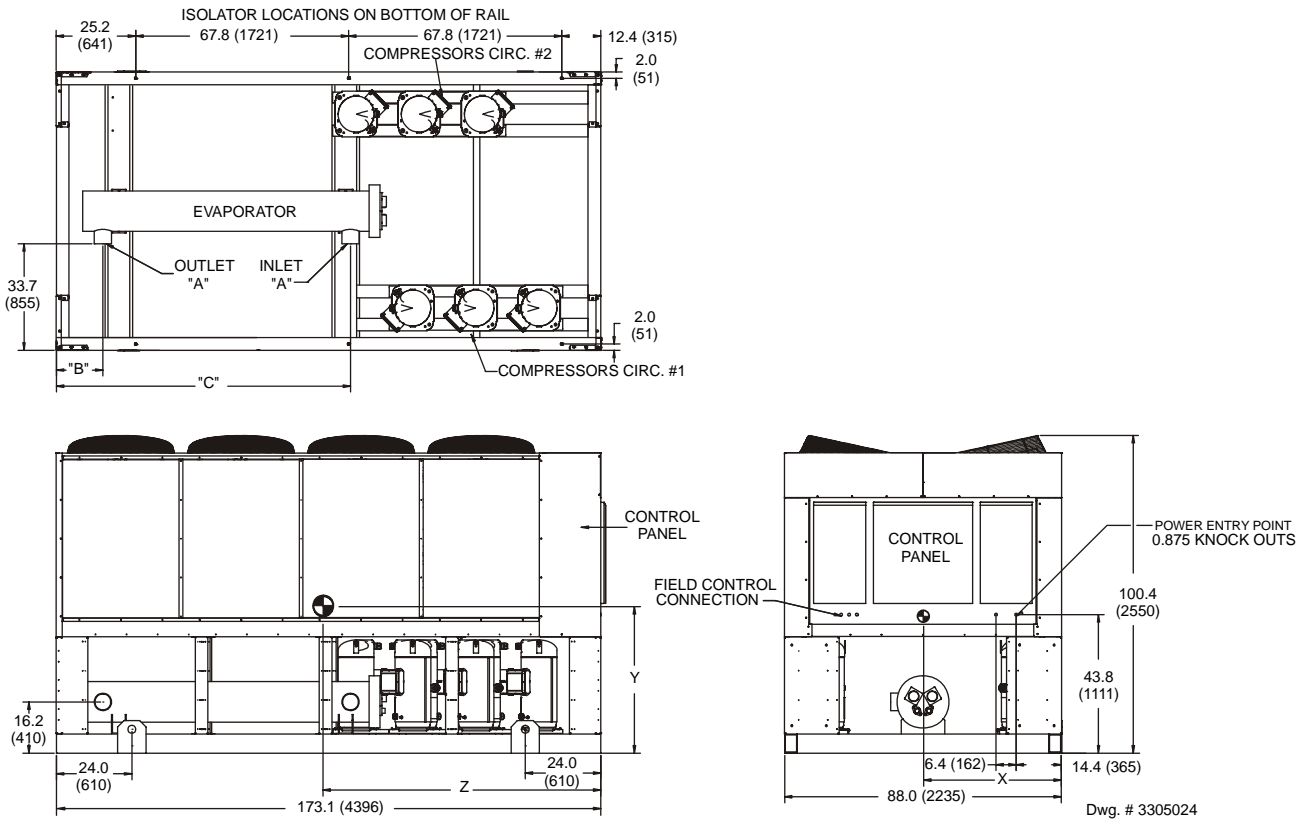

NOTE: Hail and wind guards add 20 inches to the width of each side.

Unit Size	Center of Gravity Inches (mm)			Evap Inlet & Outlet Victaulic "A" in.	Weights Lbs. (kg)	
	X	Y	Z		Shipping Weight	Operating Weight
AGZ 100BS/BH	43 (1092)	43 (1092)	76 (1930)	5	7580 (3438)	7870 (3570)
AGZ 110BS/BH	44 (1118)	43 (1092)	75 (1905)	5	7860 (3565)	8150 (3697)
AGZ 120BS/BH	43 (1092)	40 (1016)	75 (1905)	8	8380 (3801)	8720 (3955)
AGZ 130BS/BH	44 (1118)	38 (965)	74 (1880)	8	8710 (3951)	9050 (4105)

Figure 17, Dimensions, AGZ 010AM - 017AM w/ Remote Evaporator

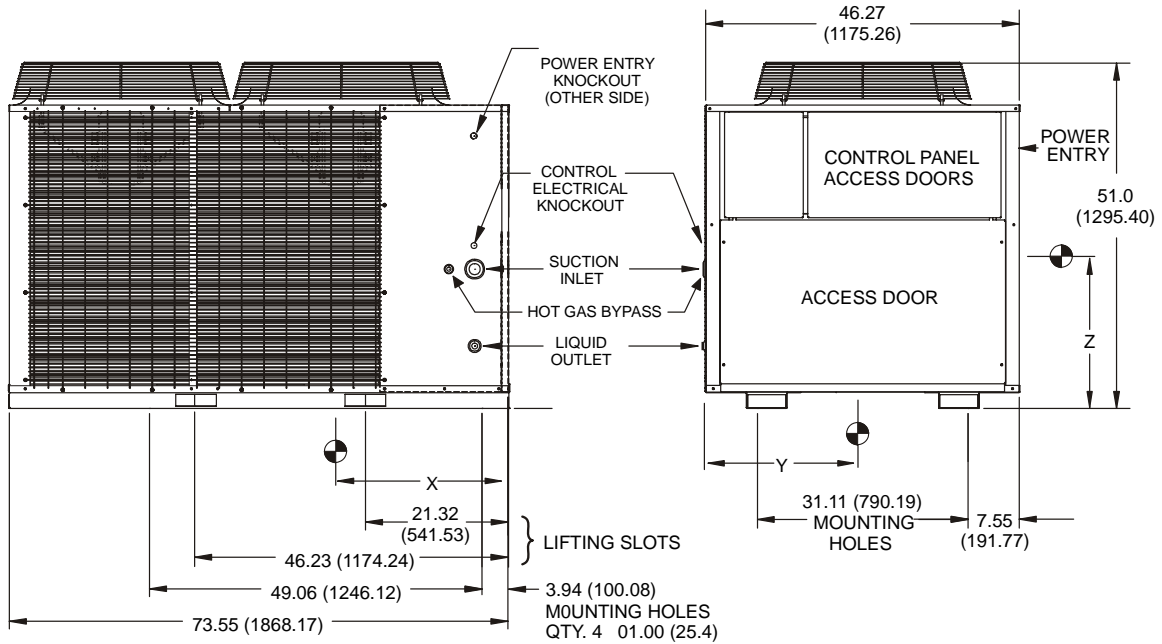

AGZ-AM Unit Size	Liquid Conn. inches (mm)	Suction Conn. inches (mm)	Optional Hot Gas Bypass	Center of Gravity inches (mm)		
				X	Y	Z
010	7/8 (22.2)	1 1/8 (28.6)	5/8 (15.8)	28 (711.2)	22 (558.8)	23 (584.2)
013, 017	7/8 (22.2)	1 5/8 (41.3)	5/8 (15.8)	25 (635.0)	21 (553.4)	23 (584.2)

Figure 18, AGZ 020AM - 034AM w/ Remote Evaporator

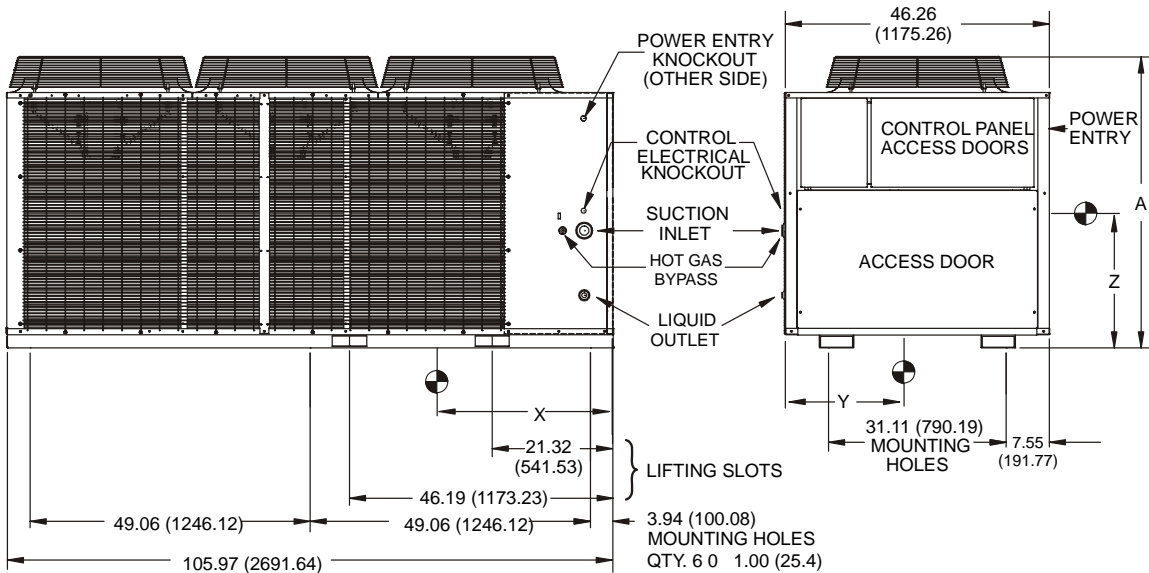

AGZ Unit Size	A inches (mm)	Liquid Conn. inches (mm)	Suction Conn. inches (mm)	Optional Hot Gas Bypass	Center of Gravity inches (mm)		
					X	Y	Z
020, 025	51 (1295)	7/8 (22.2)	1 5/8 (41.3)	5/8 (15.8)	35 (889.0)	21 (553.4)	23 (584.2)
029, 034	59 (1499)	7/8 (22.2)	2 1/8 (53.9)	5/8 (15.8)	35 (889.0)	25 (635.0)	24 (609.6)

Figure 19, Dimensions, AGZ 026BM/BB - 070BM/BB, w/ Remote Evaporator

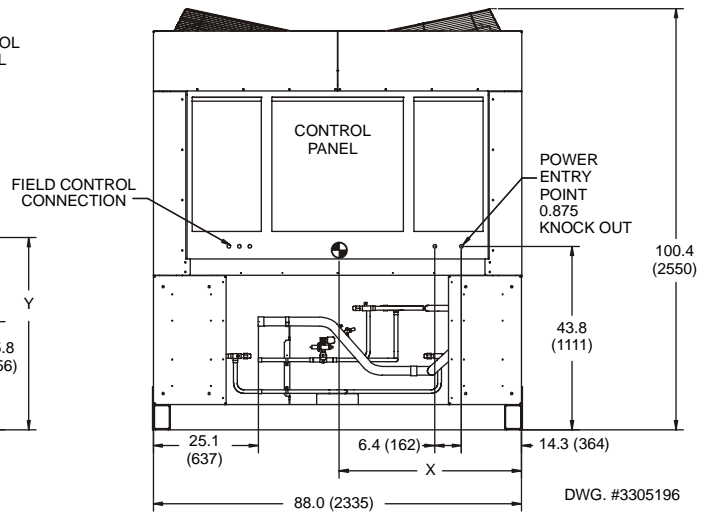
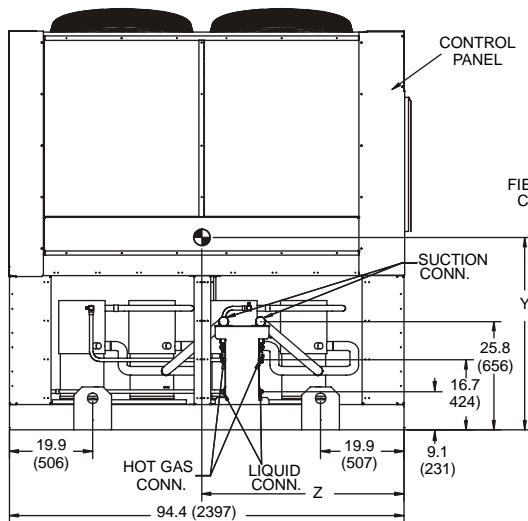
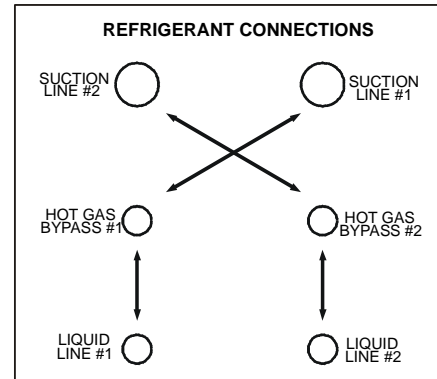
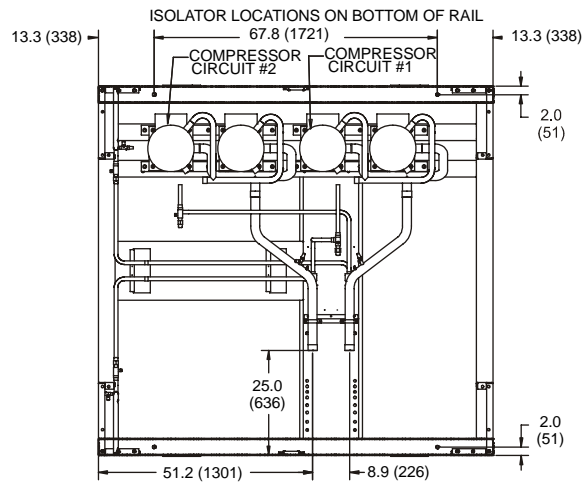

NOTE: Hail and wind guards add 20 inches to the width of each side.

AGZ-BM/BB Size	Liquid Conn. inches	Suction Conn. inches		Optional Hot Gas Bypass	Center of Gravity Inches (mm)			Weights Lbs. (kg)	
		Circuit 1	Circuit 2		X	Y	Z	Shipping Weight	Operating Weight
026	(2) 7/8	1 5/8	1 5/8	(2) 7/8	36 (914)	42 (1067)	42 (1067)	3550 (1610)	3600 (1633)
030	(2) 7/8	1 5/8	1 5/8	(2) 7/8	36 (914)	42 (1067)	42 (1067)	3550 (1610)	3600 (1633)
035	(2) 7/8	1 5/8	1 5/8	(2) 7/8	36 (914)	42 (1067)	42 (1067)	3550 (1610)	3600 (1633)
040	(2) 7/8	1 5/8	1 5/8	(2) 7/8	36 (914)	41 (1041)	41 (1041)	3550 (1610)	3610 (1637)
045	(2) 7/8	1 5/8	1 5/8	(2) 7/8	36 (914)	41 (1041)	41 (1041)	3590 (1628)	3650 (1656)
050	(2) 7/8	1 5/8	1 5/8	(2) 7/8	36 (914)	42 (1067)	42 (1067)	3730 (1692)	3800 (1724)
055	(2) 7/8	1 5/8	2 1/8	(2) 7/8	35 (889)	42 (1067)	43 (1092)	3780 (1715)	3850 (1746)
060	(2) 7/8	2 1/8	2 1/8	(2) 7/8	35 (889)	42 (1067)	43 (1092)	3820 (1733)	4040 (1833)
065	(2) 7/8	2 1/8	2 5/8	(2) 7/8	35 (889)	43 (1092)	45 (1143)	3970 (1801)	4070 (1846)
070	(2) 7/8	2 5/8	2 5/8	(2) 7/8	36 (914)	44 (1118)	46 (1168)	4080 (1851)	4180 (1896)

Figure 20, Dimensions, AGZ 075BM/BB - 090BM/BB, w/ Remote Evaporator

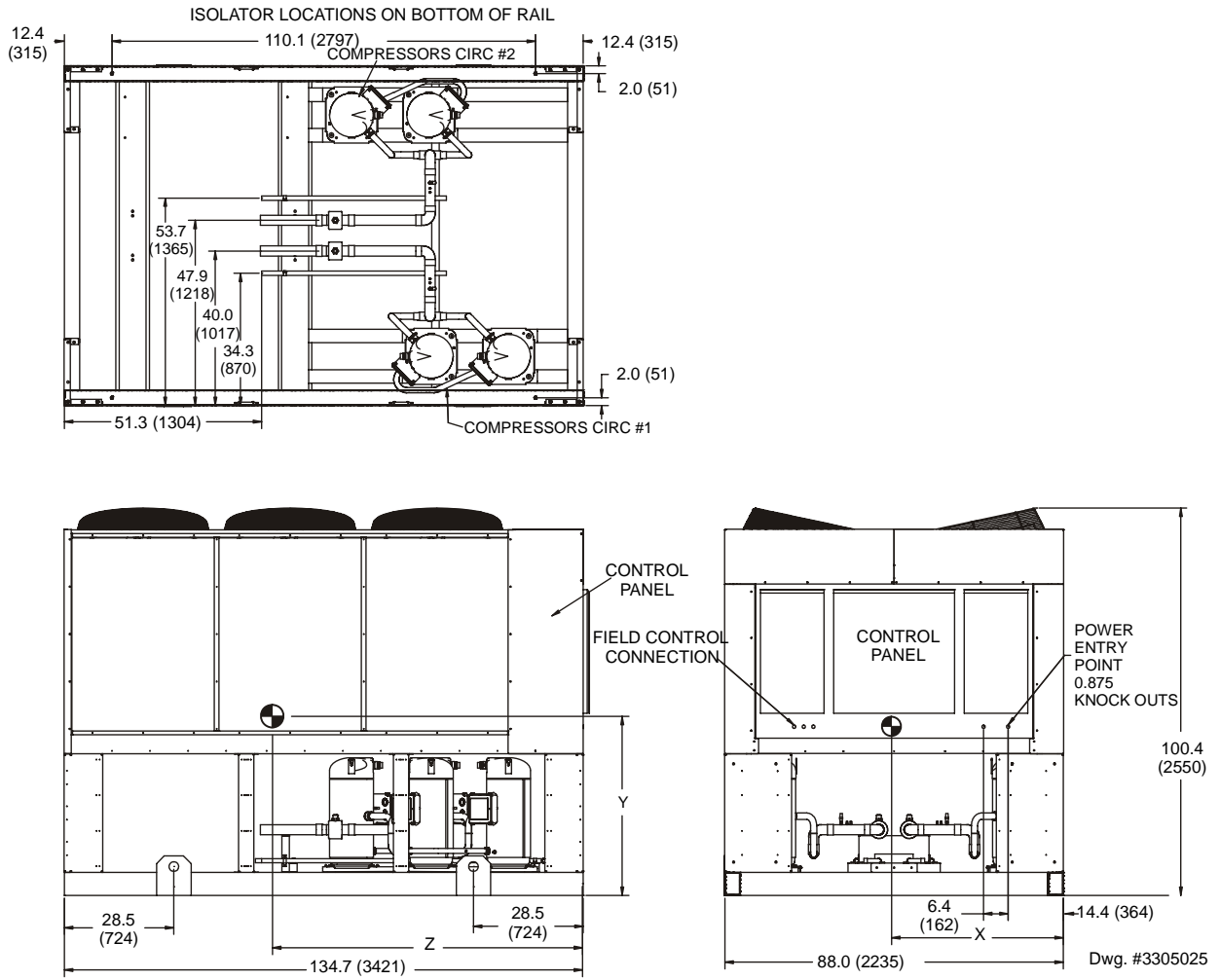

NOTE: Hail and wind guards add 20 inches to the width of each side.

AGZ-BM/BB Size	Liquid Conn. inches	Suction Conn. inches		Optional Hot Gas Bypass	Center of Gravity Inches (mm)			Weights Lbs. (kg)	
		Cir. 1	Cir. 2		X	Y	Z	Shipping Weight	Operating Weight
075	(2) 1 1/8	2 5/8	2 5/8	1 1/8	44 (1118)	46 (1168)	58 (1473)	5510 (2499)	5630 (2554)
085	(2) 1 1/8	2 5/8	3 1/8	1 1/8	43 (1092)	44 (1118)	58 (1473)	5670 (2572)	5790 (2626)
090	(2) 1 1/8	3 1/8	3 1/8	1 1/8	44 (1118)	41 (1041)	57 (1448)	5830 (5830)	5950 (2699)

Figure 21, Dimensions, AGZ 100BM/BB - 130BM/BB, w/Remote Evaporator

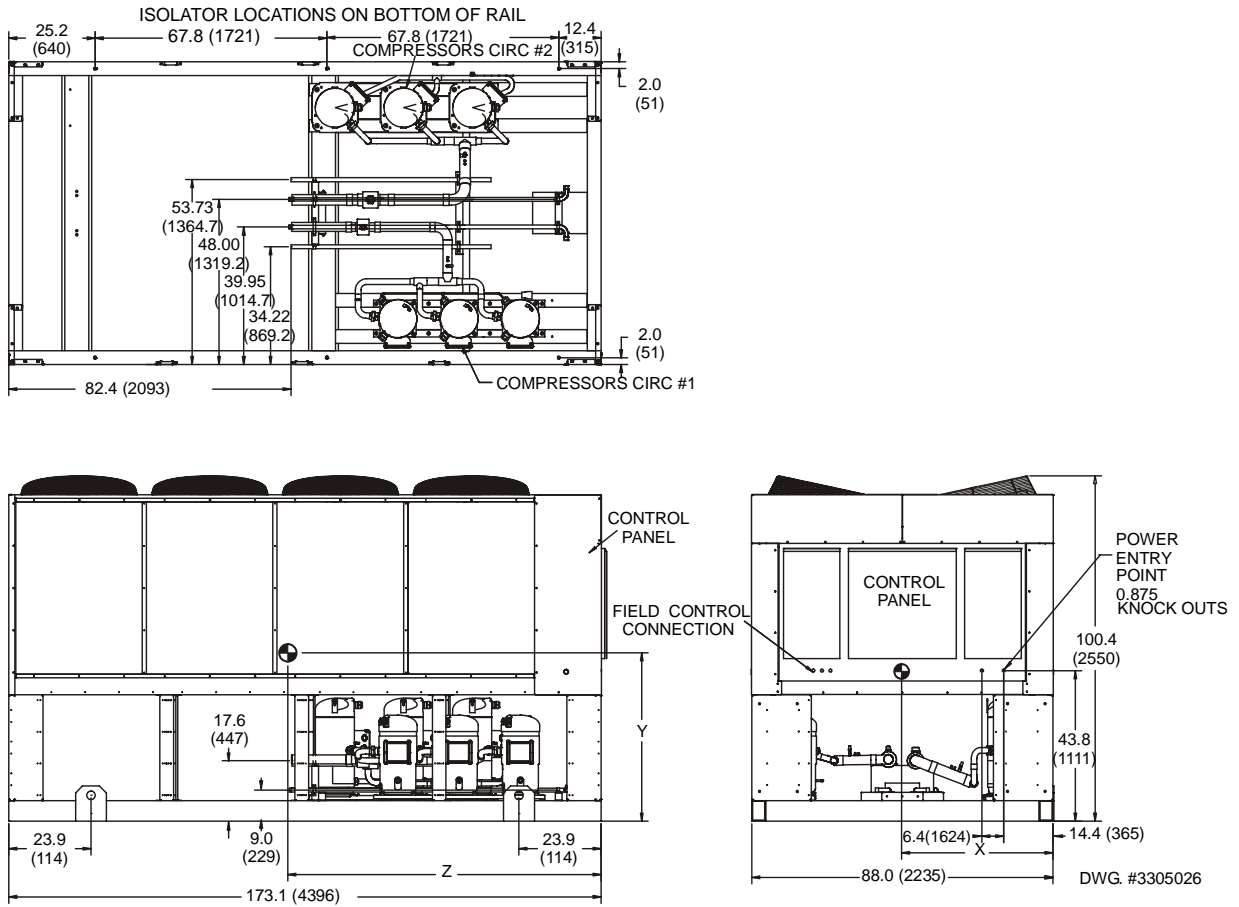

NOTE: Hail and wind guards add 20 inches to the width of each side.

AGZ-BM/BB Size	Liquid Conn. inches	Suction Conn. inches		Optional Hot Gas Bypass	Center of Gravity Inches (mm)			Weights Lbs. (kg)	
		Circuit 1	Circuit 2		X	Y	Z	Shipping Weight	Operating Weight
100	(2) 1 1/8	2 5/8	3 1/8	1 1/8	43 (1092)	46 (1168)	75 (1905)	6820 (3094)	6970 (3162)
110	(2) 1 1/8	3 1/8	3 1/8	1 1/8	44 (1118)	46 (1168)	73 (1854)	7080 (3211)	7230 (3280)
120	(2) 1 1/8	3 1/8	3 1/8	1 1/8	43 (1092)	63 (1600)	73 (1854)	7360 (3338)	7480 (3393)
130	(2) 1 1/8	3 1/8	3 1/8	1 1/8	44 (1118)	40 (1016)	71 (1803)	7640 (3466)	7760 (3520)

Remote Evaporators

Figure 22, Remote Evaporators, for AGZ 010AM – 034AM

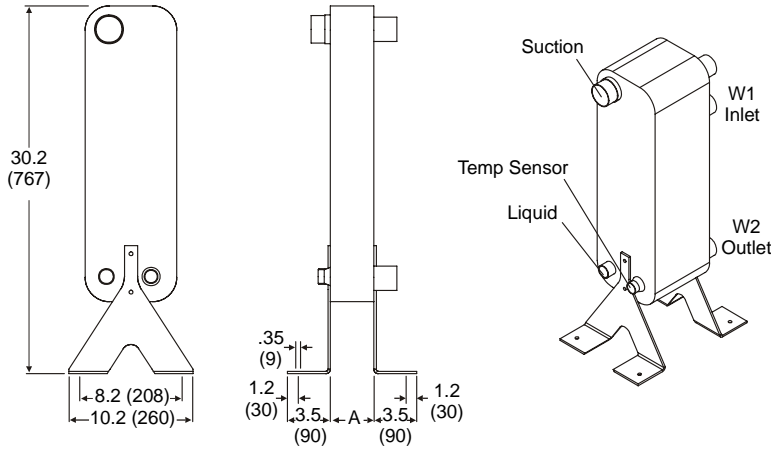

AGZ Model	Liquid Line Conn. Brazed, in (L).	Suction Line Conn. Brazed, in (S).	Temp. Sensor NPT, in. (TS)	Victaulic Water Conn. In. (W)	Dimension "A" in. (mm)
010	1.125	2.125	0.75	2.0	3.6 (91)
013	1.125	2.125	0.75	2.0	6.0 (153)
017	1.125	2.125	0.75	2.0	7.1 (181)
020	1.125	2.125	0.75	2.0	7.7 (195)
025	1.125	2.125	0.75	2.0	10.6 (271)
029	1.375	2.125	0.75	2.0	13.8 (351)
034	1.375	2.125	0.75	2.0	19.0 (483)

Figure 23, Remote Evaporators, AGZ 026BM/BB – 070BM/BB

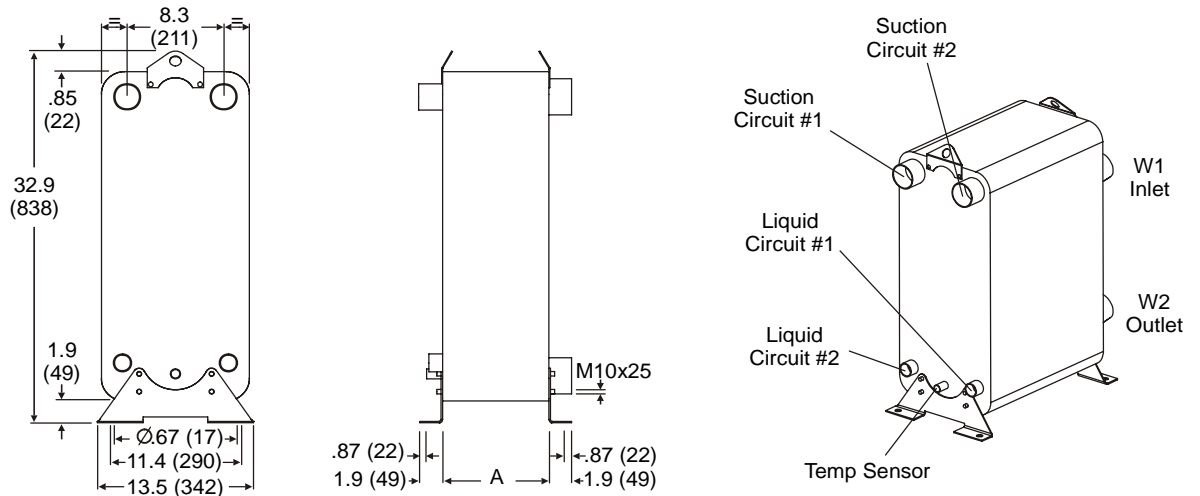

AGZ Model	Liquid Line Conn. Brazed, in (L).	Suction Line Conn. Brazed, in (S).	Temp. Sensor NPT, in. (TS)	Victaulic Water Conn. In. (W)	Dimension "A" in. (mm)
026	1.375	2.125	0.75	3.0	8.3 (210)
030	1.375	2.125	0.75	3.0	8.3 (210)
035	1.375	2.125	0.75	3.0	9.2 (233)
040	1.375	2.125	0.75	3.0	10.5 (267)
045	1.375	2.125	0.75	3.0	11.8 (300)
050	1.375	2.125	0.75	3.0	13.1 (336)
055	1.375	2.125	0.75	3.0	15.0 (380)
060	1.375	2.625	0.75	3.0	16.7 (425)
065	1.375	2.625	0.75	3.0	19.0 (481)
070	1.375	2.625	0.75	3.0	19.0 (481)

Figure 24, Remote Evaporators, AGZ 075BM/BB - 130BM/BB

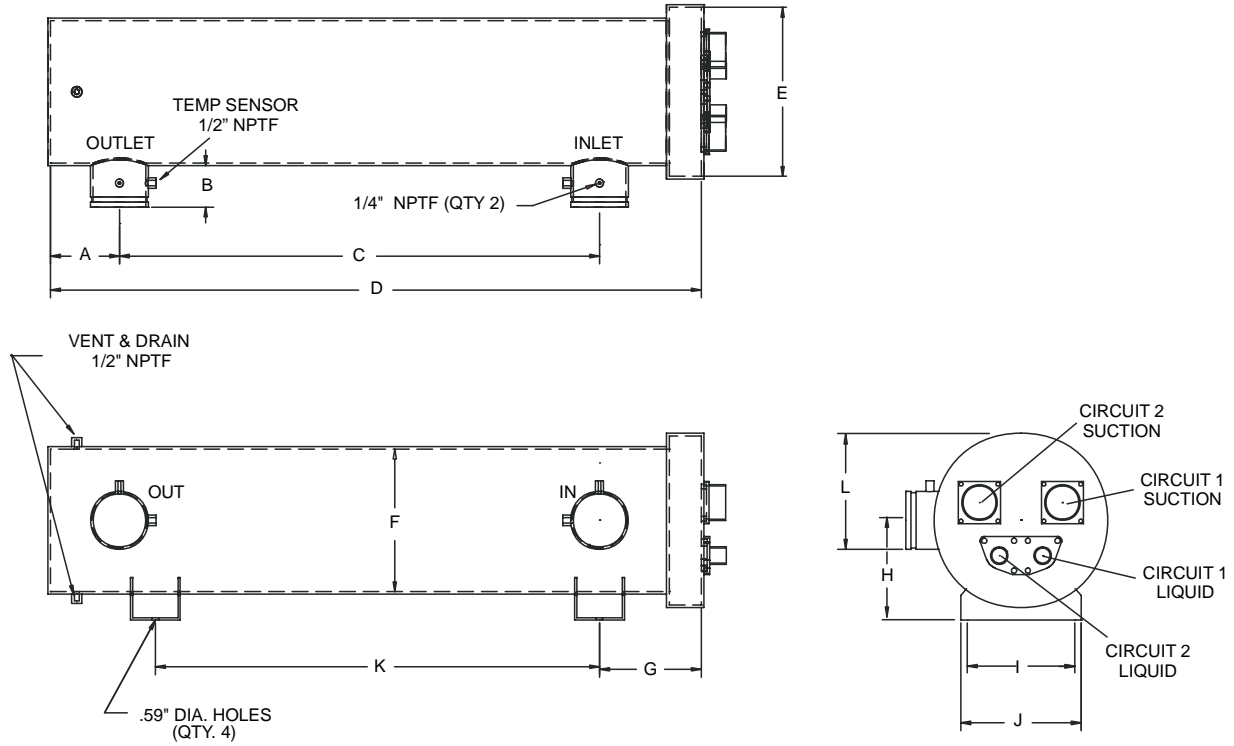

AGZ Model	A	B	C	D	E	F	G	H	I	J	K	L	W (Water)	S (Suction)	L (Liquid)
075	6.6	3.9	45.9	61.9	16.0	13.5	9.7	9.5	10.2	11.4	42.2	17.7	(2) 5.0	(2) 3.125	(2) 1.375
085	6.6	3.9	45.9	61.9	16.0	13.5	9.7	9.5	10.2	11.4	42.2	17.7	(2) 5.0	(2) 3.125	(2) 1.375
090	6.6	3.9	45.9	61.9	16.0	13.5	9.7	9.5	10.2	11.4	42.2	17.7	(2) 5.0	(2) 3.125	(2) 1.375
100	6.4	3.9	85.2	94.6	15.3	12.8	11.0	10.2	12.6	13.8	72.1	17.8	(2) 5.0	(2) 3.125	(2) 1.375
110	6.4	3.9	85.2	94.6	15.3	12.8	11.0	10.2	12.6	13.8	72.1	17.8	(2) 5.0	(2) 3.125	(2) 1.375
120	6.8	4.0	84.0	95.5	16.5	14.0	11.9	10.2	12.6	13.8	72.1	18.4	(2) 8.0	(2) 3.125	(2) 1.375
130	6.8	4.0	84.0	95.5	16.5	14.0	11.9	10.2	12.6	13.8	72.1	18.4	(2) 8.0	(2) 3.125	(2) 1.375

NOTES:

1. Water connections are victaulic sized in inches.
2. Refrigerant connections are IDS sized in inches.

Application Data

Unit Placement

AGZ units are for outdoor applications and can be mounted either on a roof or at ground level. For roof mounted applications, install the unit on a steel channel or I-beam frame to support the unit above the roof. For ground level applications, install the unit on a substantial base that will not settle. Use a one-piece concrete slab with footings extended below the frost line. Be sure the foundation is level within 1/2" (13mm) over its length and width. The foundation must be strong enough to support the weights listed in the Physical Data Tables beginning on page 61.

Figure 25, Clearances

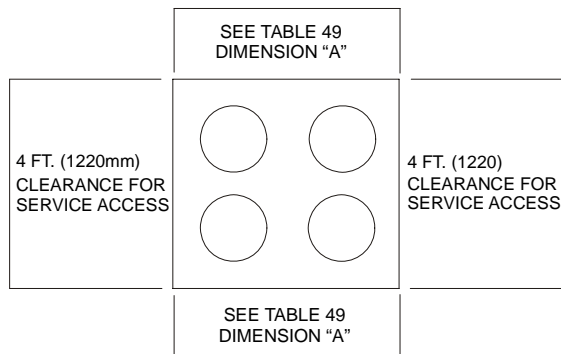

Table 56, Recommended Minimum Clearances

Model Size	Coil Side "A"	"B"	"C"	End Opposite Controls	Control Panel End	Evaporator Removal
010A - 034A	4 (1.2)	8	6	4 (1.2)	4 (1.2)	Nothing Extra
026B - 070B	4 (1.2)	8	6	4 (1.2)	4 (1.2)	Nothing Extra
075B - 130B	6 (1.8)	12	8	4 (1.2)	4 (1.2)	Nothing Extra

NOTE: Dimensions in ft (m).

Clearances

Do not block the flow of air to and from the condenser coil. Restricting airflow or allowing air recirculation will result in a decrease in unit performance and efficiency because discharge pressures are increased. There must be no obstruction above the unit that would deflect discharge air downward where it could be recirculated back to the inlet of the condenser coil. The condenser fans are propeller type and will not operate with ductwork.

Install the unit with enough side clearance for air entrance to the coil and for servicing. Provide service access to the evaporator, compressors, electrical control panel and piping components.

Do not allow debris to accumulate near the unit where it could be drawn into the condenser coil. Keep condenser coils and fan discharge free of snow and other obstructions to permit adequate airflow for proper operation.

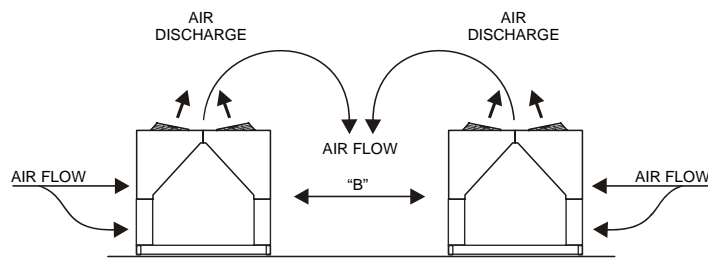

The recommended minimum side clearance between two units is dimension "B" in Table 49.

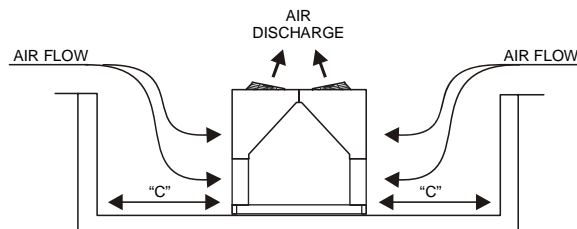

The unit must not be installed in a pit or enclosure that is deeper or taller than the height of the unit unless extra space is provided. The minimum clearance on each side of the unit is dimension "C" in Table 49.

Restricted Air Flow

General

The clearances required for design-life operation of AGZ air-cooled condensers are described in the previous section. Occasionally, these clearances cannot be maintained due to site restrictions such as units being too close together or a fence or wall restricting airflow, or both.

Fortunately, the McQuay AGZ chillers have several features that can mitigate the penalties attributable to restricted airflow.

- The condenser section is “W” shaped, as shown below. This allows inlet air for these coils to come in from either side. A vertical coil and its adjacent angled coil are manifolded together to serve one circuit. Every compressor set has its own independent refrigerant circuit.
- The MicroTech II™ control is proactive in response to “off-design conditions”. In the case of single or compounded influences restricting airflow to the unit, the microprocessor will act to keep the unit running (possibly at reduced capacity) rather than allowing a complete shut-off on high discharge pressure.
- The MicroTech II™ control can be programmed to sequence the compressors in the most advantageous way. For example, in the diagram shown below, it might be desirable to program circuit #1 to be the lag circuit (last circuit to reach full load) during periods of high ambient temperatures.

Figure 26, Coil and Fan Arrangement

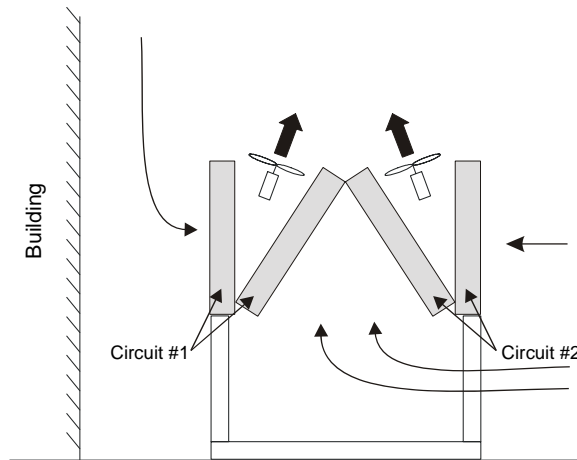

The following sections discuss the most common situations of condenser air restriction and give capacity and power adjustment factors for each. Note that in unusually severe conditions, the MicroTech II™ controller would adjust the unit operation to remain online until a less severe condition is reached.

Case 1, Building or Wall on One Side of One Unit

The existence of a screening wall or the wall of a building in close proximity to an air-cooled chiller is common in both rooftop and ground level applications. Hot air recirculation on the coils adjoining the wall will increase compressor discharge pressure, decreasing capacity and increasing power consumption. Only the compressor(s) connected to these coils will be affected. Circuits opposite the wall are unaffected.

When close to a wall, it is desirable to place chillers on the North or East side of the walls. It is also desirable to have prevailing winds blowing parallel to the unit's long axis. The worst case is to have wind blowing hot discharge air into the wall.

Figure 27, Unit Adjacent to Wall

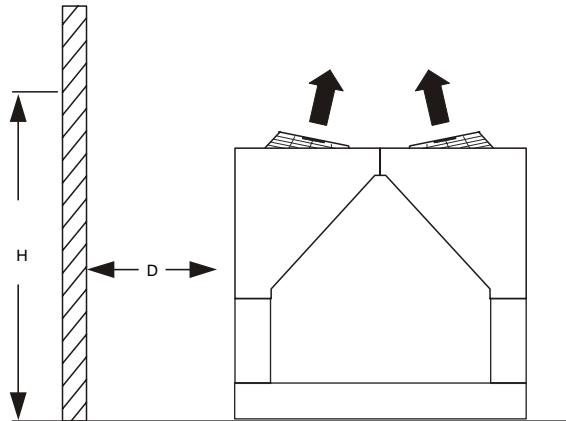
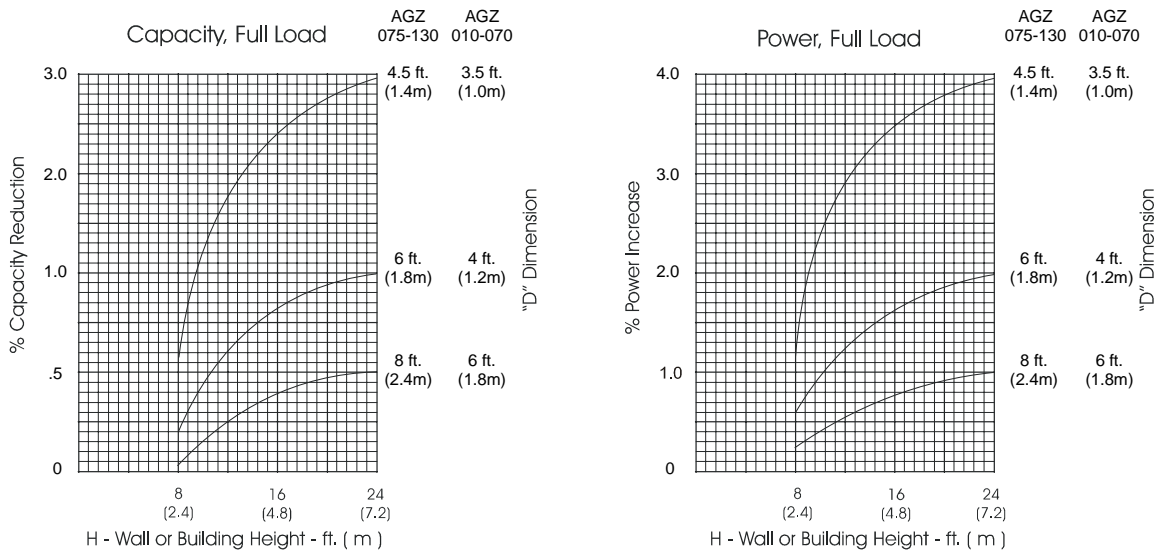

Figure 28, Adjustment Factors



Case 2, Two Units Side By Side

Two or more units sited side by side are common. If spaced closer than 12 feet (3.7 meters) or 8 feet (2.5 meters) depending on size, it is necessary to adjust the performance of each unit; circuits adjoining each other are affected. **NOTE:** This case applies only to *two* units side by side. See Case 3 for three or more parallel units. If one of the two units also has a wall adjoining it, see Case 1. Add the two adjustment factors together and apply to the unit located between the wall and the other unit.

Mounting units end to end will not necessitate adjusting performance. Depending on the actual arrangement, sufficient space must be left between the units for access to the control panel door opening and/or evaporator tube removal. See “Clearance” section of this guide for requirements for specific units.

Figure 29, Two Units Side by Side

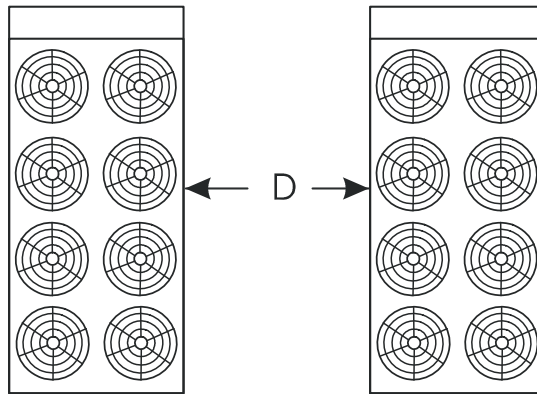
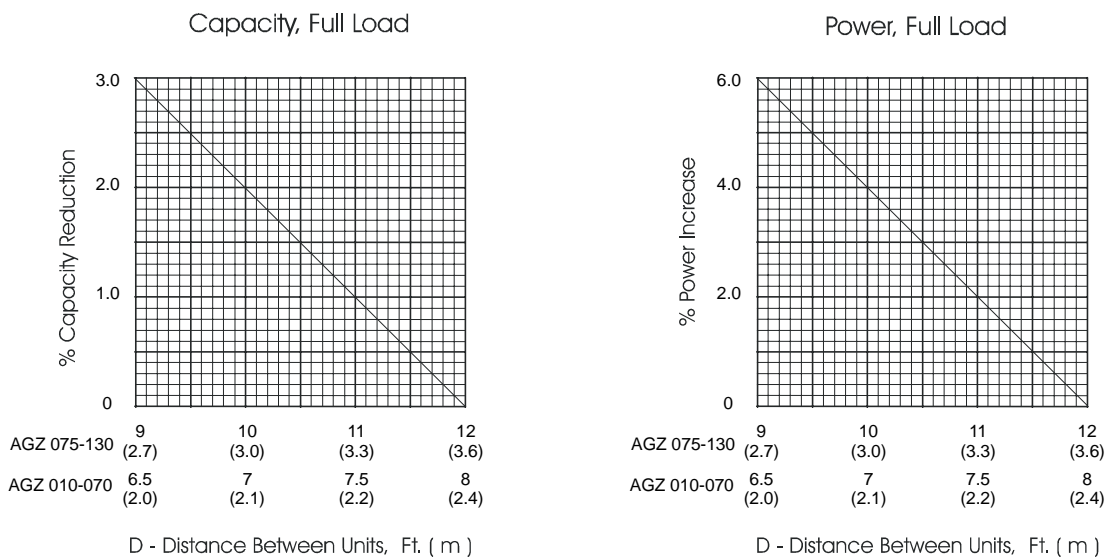

Figure 30, Adjustment Factor



Case 3, Three or More Units Side By Side

When three or more units are side by side, the outside chillers (1 and 3 in this case) are influenced by the middle unit only on their inside circuits. Their adjustment factors will be the same as Case 2. All inside units (only number 2 in this case) are influenced on both sides and must be adjusted by the factors shown below.

Figure 31, Three or More Units

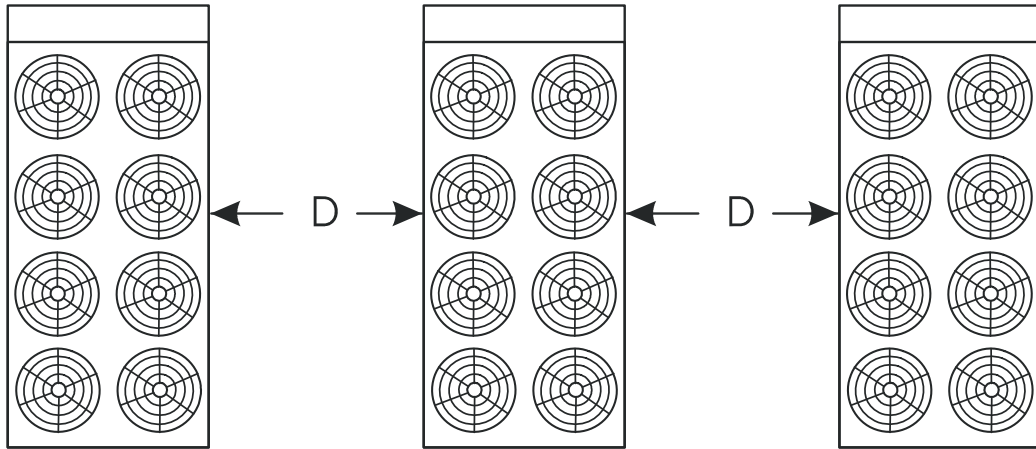
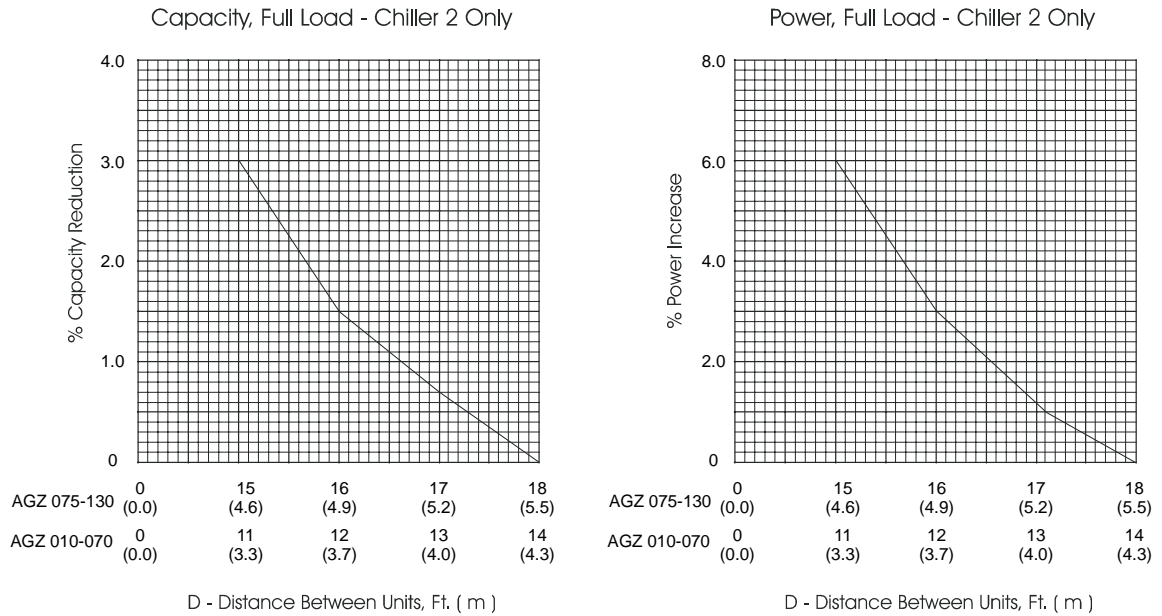

Figure 32, Adjustment Factor



Case 4, Open Screening Walls

Decorative screening walls are often used to help conceal a unit either on grade or on a rooftop. These walls should be designed such that the combination of their open area and distance from the unit do not require performance adjustment. It is assumed that the wall height is equal to or less than the unit height when mounted on its base support. This is usually satisfactory for concealment. If the wall height is greater than the unit height, see Case 5, Pit Installation.

The distance from the ends of the unit to the end walls should be sufficient for service, opening control panel doors, and pulling evaporator tubes, as applicable.

If each side wall is a different distance from the unit, the distances can be averaged providing either wall is not less than 8 feet (2.4 meters) from the unit. For example, do not average 4 feet and 20 feet to equal 12 feet.

Figure 33, Open Screening Walls

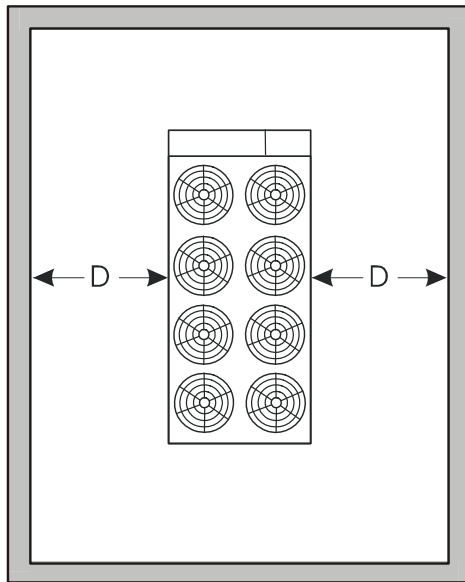
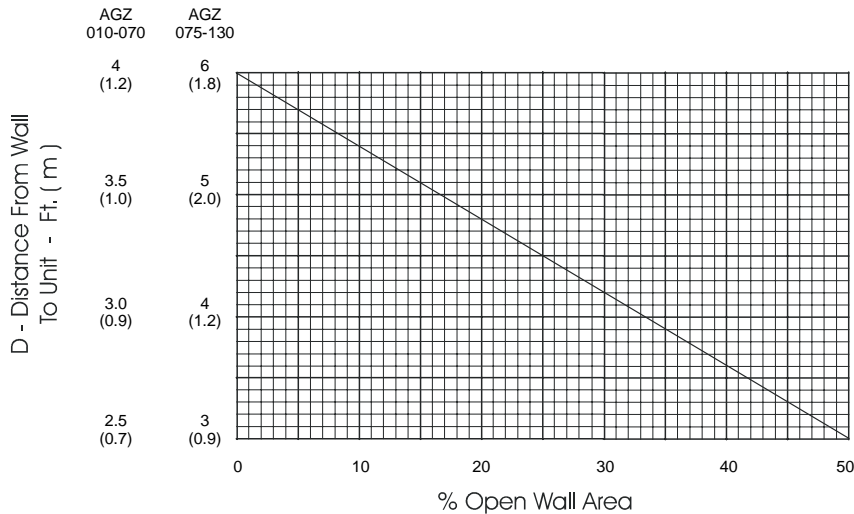

Figure 34, Wall Free Area vs Distance



Case 5, Pit/Solid Wall Installation

Pit installations can cause operating problems. Great care should be exercised if they are to be used on an installation. Recirculation and restriction can both occur. A solid wall surrounding a unit is substantially the same as a pit and the data presented here should be used.

Steel grating is sometimes used to cover a pit to prevent accidental falls or trips into the pit. The grating material and installation design must be strong enough to prevent such accidents, yet provide abundant open area or serious recirculation problems will occur. Have any pit installation reviewed by McQuay application engineers prior to installation to make sure it has sufficient air-flow characteristics. The installation design engineer must approve the work to avoid an unreasonable risk of accident.

Figure 35, Pit Installation

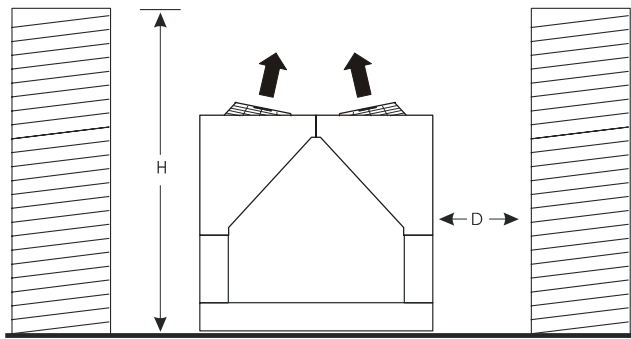
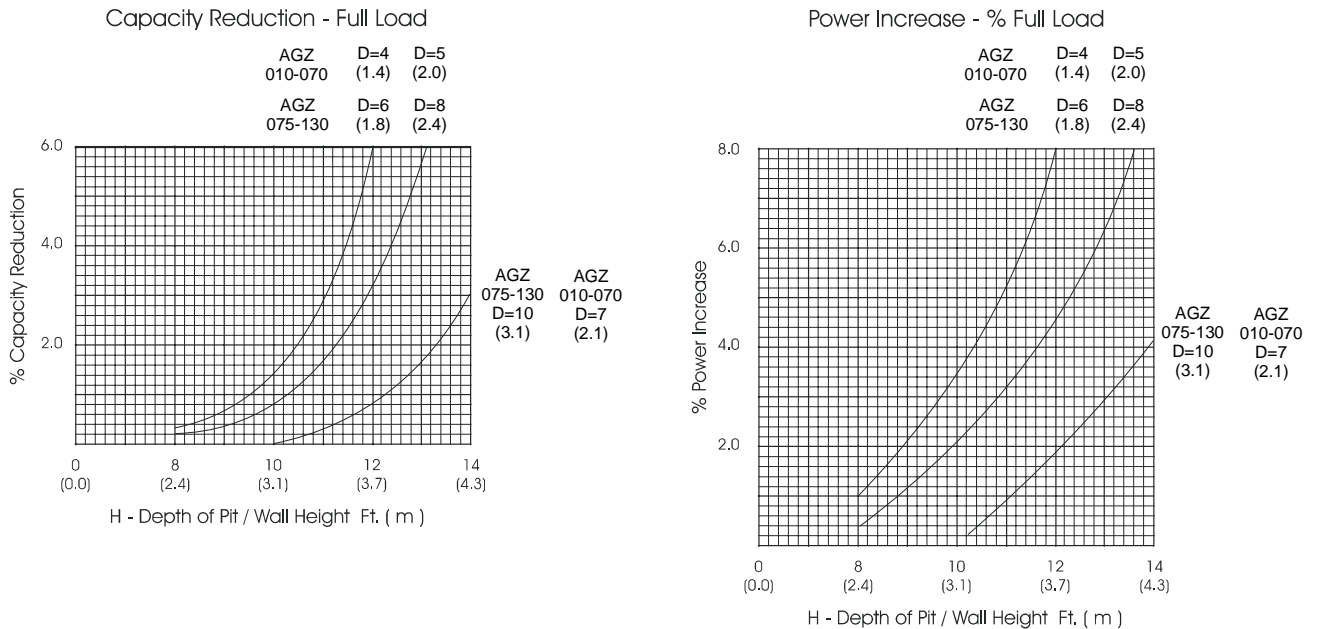

Figure 36, Adjustment Factor



Sound Isolation

The ultra-low sound levels for the AGZ chiller is sufficient for most applications. However, there will be applications where sound generation can be an issue. The most effective isolation method is to locate the unit away from sound sensitive areas. Avoid locations beneath windows or between structures where normal operating sounds can be objectionable. Reduce structurally transmitted sound by isolating water lines, electrical conduit and the unit itself. Use wall sleeves and rubber isolated piping hangers to reduce transmission of water or pump noise into occupied spaces. Use flexible electrical conduit to isolate sound through electrical conduit. Spring isolators are effective in reducing the low amplitude sound generated by scroll compressors and for unit isolation in sound sensitive areas.

Optional sound reducing enclosures (compressor blankets) are available as an option for critical areas.

Typical Chilled Water Piping

Flush the system water piping thoroughly before making connections to the unit evaporator. Be sure to install a strainer (40 mesh for models AGZ 010 through 070 and 20-mesh for AGZ 075 through 130) in the return water line before the inlet to the chiller. Design the water piping so the chilled water circulating pump discharges into the evaporator inlet.

Connect the return water line to the evaporator inlet connection. Connect the supply water line to the evaporator outlet connection.

Install a flow switch in the horizontal piping of the supply (evaporator outlet) water line.

Provide drain connections at low points in the system to permit complete drainage of the system. Locate air vents at the high points in the system to purge air out of the system. A vent connection on top of the evaporator vessel allows air to be purged out of the evaporator. Purge air from the water system before unit start-up to provide adequate flow through the evaporator.

Install pressure gauges in the inlet and outlet water lines to the evaporator. Measure pressure drop through the evaporator and compare to flow as shown in Figure 9. Vibration eliminators are recommended in both the supply and return water lines.

Insulate chilled water piping to reduce heat loss and prevent condensation. Chillers not running in the winter should have their water systems thoroughly drained to protect against freezing. If the chiller operates year round, or if the system is not drained for the winter, protect the chilled water piping exposed to outdoor temperature against freezing. Wrap the lines with a heater cable and add proper amount of glycol to the system to further protect the system.

The thermostat sensor is factory mounted in the leaving water well. If an optional high return water sensor is provided, install sensor bulb in a field supplied tee or strap to the outside of the water line.

Water Flow Limitations, Constant Flow

The evaporator flow rates and pressure drops show on page 37 are for full load design purposes. The maximum flow rate and pressure drop are based on a 6-degree temperature drop. Avoid higher flow rates with resulting lower temperature drops to prevent potential control problems resulting from very small control bands and limited start up/shut off temperature changes.

The minimum flow and pressure drop is based on a full load evaporator temperature drop of 16-degrees.

Evaporator flow rates below the minimum values can result in laminar flow causing freeze-up problems, scaling and poor control. Flow rates above the maximum values will result in unacceptable pressure drops and can cause excessive erosion, potentially leading to failure.

Water Flow Limitations, Variable Flow

The full load, minimum flow limitation for constant flow is not to be confused with the part load minimum flow rate that must be maintained for chillers operating in primary *variable* flow pumping systems. As chiller capacity drops, the flow rate for this pumping system will reduce proportionally. See the following table for the *part load* minimum flow rates.

Other design practices for variable flow systems requiring a range of evaporator flow rates can be found below.

These minimum flow rates assume that flow will be reduced proportionally to the cooling load.

Table 57, Minimum Part Load Flow Rates

AGZ Model	010	013	017	020	025	029	034	026	030	035	040	045
Minimum Part Load Flow (GPM)	10	13	15	20	22	27	33	26	29	32	37	41
AGZ Model	050	055	060	065	070	075	085	090	100	110	120	130
Minimum Part Load Flow (GPM)	45	50	55	59	63	71	119	128	146	161	180	194

Variable Speed Pumping

Variable water flow involves changing the water flow through the evaporator as the load changes. McQuay chillers are designed for this duty provided that the rate of change in water flow is slow and the minimum and maximum flow rates for the vessel are not exceeded.

The recommended maximum change in water flow is 10 percent of the change per minute.

The water flow through the vessel must remain between the minimum and maximum values listed on page 37. If flow drops below the minimum allowable, large reductions in heat transfer can occur. If the flow exceeds the maximum rate, excessive pressure drop and tube erosion can occur.

Figure 37, Typical Piping, Shell and Tube Evaporator

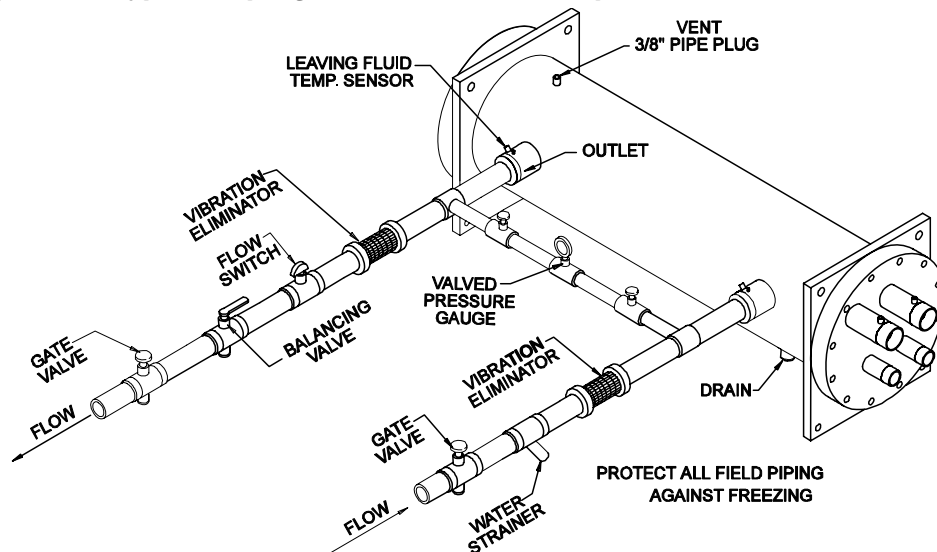
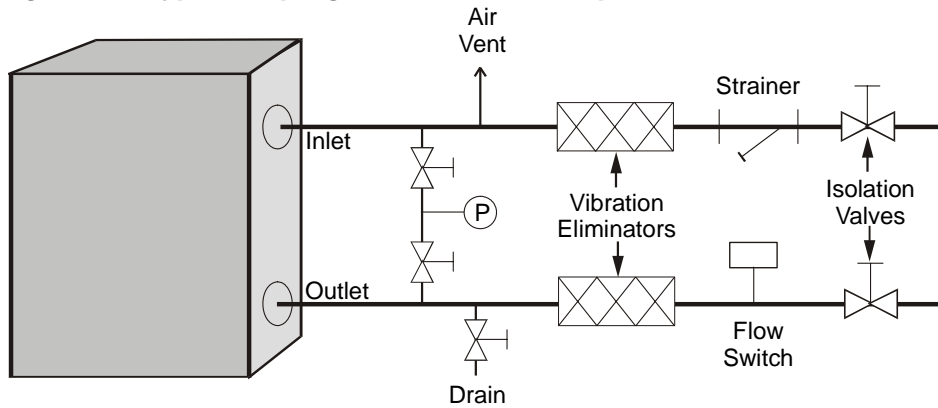

Figure 38, Typical Piping, Brazed-Plate Evaporator



Piping for units with brazed-plate evaporators must have a drain and vent connection be provided in the bottom of the lower connection pipe and to the top of the upper connection pipe respectively. These evaporators do not have drain or vent connections due to their construction.

Temperature and Water Flow Limitations

Compressor loading and unloading is adaptively determined by system load, ambient air temperature, and other inputs to the MicroTech control algorithms. A low ambient option with SpeedTrol (on AGZ 010A to 034A) and fan VFD (on AGZ 026B to 130B) allows operation down to 0°F (-18°C). The minimum ambient temperature is based on still conditions where the wind is not greater than five mph. Greater wind velocities will result in reduced discharge pressure, increasing the minimum operating ambient temperature. Field installed hail/wind guards are available to allow the chiller to operate effectively down to the ambient temperature for which it was designed.

Evaporator flow rates below the minimum values can result in laminar flow causing freeze-up problems, scaling and poor control. Flow rates above the maximum values will result in unacceptable pressure drops and can cause excessive erosion, potentially leading to failure.

System Water Volume Considerations

All chillers need adequate time to recognize a load change, respond to the change and stabilize without short cycling the compressor. The water volume in the system and the size of the piping loop is a critical consideration. Good engineering practice is to have a minimum water volume of four times the flow rate (GPM) for comfort cooling applications. For process applications where the load can change quickly, contact the local McQuay sales office for recommendations. A water storage tank (provided by others) may be required to increase the system water volume in some systems.

Since there are many other factors that can influence performance, systems can successfully operate below these suggestions. However, as the water volume decreases below these suggestions, the possibility of problems increases. We believe that these guidelines should be an industry standard and not just recommendations from McQuay.

Evaporator Freeze Protection

Evaporator freeze-up can be a concern in the application of air-cooled water chillers. To protect against freeze-up, insulation and an electric heater cable are furnished with the unit. This protects the evaporator down to -20°F (-29°C) ambient air temperature. Although the evaporator is equipped with freeze protection, it does not protect water piping external to the unit or the evaporator itself if there is a power failure or heater cable burnout. Consider the following recommendations for additional protection.

1. If the unit will not be operated during the winter, drain evaporator and chilled water piping and flush with glycol. Drain and vent connections are provided on the evaporator to ease draining.
2. Add a glycol solution to the chilled water system to provide freeze protection. Freeze point should be approximately ten degrees below minimum design ambient temperature.
3. The addition of thermostatically controlled heat and insulation to exposed piping.
4. Continuous circulation of water through the chilled water piping and evaporator.

The evaporator heater cable is factory wired to the 115 volt circuit in the control box. This power should be supplied from a separate source, but it can be supplied from the control circuit. Operation of the heater cable is automatic through the ambient sensing thermostat that energizes the evaporator heater cable for protection against freeze-up. Unless the evaporator is drained in the winter, the disconnect switch to the evaporator heater must not be open.

Refrigerant Piping for AGZ-Remote Evaporators

Proper refrigerant piping can make the difference between a reliable system and an inefficient, problematic system. The primary concerns related to piping are refrigerant pressure drop, a solid liquid feed to the expansion valves, continuous oil return and properly sized refrigerant specialties.

The recommended source for refrigerant piping techniques and sizing is the ASHRAE 2002 Refrigeration Handbook, Chapter #2.

Refrigerant specialties including the expansion valves, solenoid valves, filter drier and sight glasses for use with the remote evaporator applications are supplied by McQuay but require field installation. The remaining components including fittings and Schrader valves are provided and piped by the installer. The hot gas bypass valve with solenoid valve option can be provided as a field installed or factory installed option. The condensing unit section for remote evaporator applications has a liquid line shut off valve and a suction shut off valve provided as standard. A holding charge of R22 is provided for the evaporator and an outdoor section. The installer must properly evacuate the piping system and provide the operating charge of R22. Refer to the piping schematic drawing on page 11 for additional details.

Although conflicting piping recommendations can be found in different sources, McQuay offers the following recommendations for these controversial issues.

The use of double risers for vertical gas risers is generally not required and should be used only as a last resort to maintain the minimum refrigerant flow to carry oil up the vertical risers. Slightly downsizing the vertical riser is a superior option to providing double risers.

Slope the refrigerant lines 1" per 10 feet of horizontal run in the direction of refrigerant flow to assist oil return.

Resist using hot gas bypass for applications when operation in ambient temperature below 40 degrees is expected. This recommendation helps to maintain adequate condensing pressures and liquid refrigerant at the expansion valve when condenser capacities are at their maximum.

Pressure drops in the refrigerant lines should be maintained at or below the ASHRAE recommendations and line lengths should be made as short as possible. Exceeding these recommendations will decrease performance and could impact reliability.

Small traps should be provided at the base of each major vertical gas riser to assist in the collection of oil. If vertical risers exceed more than 25 feet, install a small trap at the midpoint and not to exceed more than 20 feet intervals.

Use caution in sizing the liquid line in applications where the evaporator is above the outdoor section. The weight of the liquid refrigerant in the vertical column will decrease the pressure at the top of the riser (approximately .5 PSI per foot of vertical rise) allowing some of the refrigerant

to flash to a gas. Adequate refrigerant subcooling is needed at the outdoor section to prevent large volumes of refrigerant gas at the expansion valve.

It is recommended that the piping systems always extend above the highest component in the refrigeration system before dropping down to make the final refrigerant connections to components. This practice will hinder the draining of condensed refrigerant to the lower component when normal shutdown procedures do not occur (such as a power failure).

Pumpdown

The pumpdown capacity of AGZ units is given in the Physical Data Tables. Care should be exercised to include all equipment and lines when calculating the system charge relative to pumpdown capacity on remote evaporator units. The AGZ remote evaporators have an insignificant operating charge.

Operating/Standby Limits

Maximum standby ambient air temperature, 130°F (55°C)

Maximum operating ambient air temperature

Standard Ambient Unit, 105°F (40.6°C) and below, Models BS and BM

High Ambient Unit, above 105°F (40.6°C) to 125°F (51.7°C), Models BH and BB

Minimum operating ambient temperature (standard), 35°F (2°C)

Minimum operating ambient temperature (with optional low-ambient control), 0°F (-18°C)

Leaving chilled water temperature, 40°F to 60°F (4.4°C to 15.6°C)

Leaving chilled fluid temperatures (with anti-freeze), 20°F to 60°F (-7°C to 16°C)

Design chilled water Delta-T range, 6 degrees F to 16 degrees F (3.3 degrees C to 8.9 degrees C)

Part load minimum flow for variable flow systems, varies with unit size, see page 93.

Maximum operating inlet fluid temperature, 76°F (24°C)

Maximum non-operating inlet fluid temperature, 100°F (38°C)

Electric power supply, see page 39.

Warranty Statement

Limited Warranty

Consult your local McQuay Representative for warranty details. Refer to Form 933-430285Y. To find your local McQuay Representative, go to www.mcquay.com.

Optional Features

Controls

Hot Gas Bypass

Hot gas bypass permits unit operation down to 10% of full load capacity. This option includes a factory-mounted hot gas bypass valve, solenoid valve, and manual shutoff valve for each circuit.

Head Pressure Control

Optional SpeedTrol head pressure (on AGZ 010A to 034A) or fan VFD control (AGZ 026B to 130B) allows unit operation down to 0°F (-18°C). (Not available on 380 volt, 60 Hertz units.)

Water Flow Switch

(P/N 017503300) A water flow switch is available for field installation in the chilled water piping to avoid evaporator freeze-up under low or no flow conditions. Terminals are provided in the unit control center for field hook-up of the water flow switch. If this option is not ordered with the unit, then a field supplied water flow switch must be installed.

Alarm Bell

Field installed and wired to the control panel to provide remote indication of unit alarm condition.

Remote Operator Interface Panel

A remote interface panel, field wired to the unit, providing all the data viewable on the unit's controller, including alarm clearing and setpoint change capability. See page 15 for details.

BAS Interface (Protocol Selectability™)

A module is factory installed on the MicroTech II™ controller to provide the interface to the following standard protocols:

BACnet/IP

BACnet MS/TP

BACnet Ethernet

LONTALK (FTT-10A)

Modbus

Unit

Vibration Isolators

Spring or neoprene-in-shear vibration isolators are available for field installation to reduce vibration transmission through the unit base.

Protective Base Guards (AGZ 026B – 130B only)

Optional factory installed vinyl-coated welded wire base guards provide all-around lower unit protection on ground level installations. Coil guards are standard.

Louvers/Hail Guard/Wind Baffles

Available for the upper portion (condenser coils) and/or lower portion of unit on AGZ 026B through 130B. Selecting both will completely enclose the unit with louvers. Models AGZ 010A through 034A have louvers covering the coil only, which due to the unit design, effectively encloses the entire unit. The louvers protect the coils from hail damage and also stabilize operation during windy, low ambient operation. See page 7 for photograph.

Copper Fin Condenser Coils

Copper fin condenser coils are available as an option on all models.

Black Fin Coils

Aluminum fin stock precoated with a phenolic coating with 1000-hour salt spray resistance (ASTM B117-90).

Coated Fins

Copper or aluminum fins coated with *ElectroFin*® baked epoxy protective coating with 3000+ hour salt spray resistance (ASTM B117-90).

Evaporator Insulation

Double insulation thickness (total of 1½ inch) for high humidity areas or low fluid temperatures.

Sound Reduction

Acoustical blankets are factory-installed on each compressor. They are also available for retrofit field installation.

Hail and Wind Guards (AGZ 026B – 130B only)

A field-mounted option shipped as a kit including panels, fasteners, and instructions.

Shut-off Valves (AGZ 026B – 130B only)

Factory mounted suction and discharge shut-off valves. Liquid line shutoff valve is standard.

Refrigerant Specialties Kit

Required on AGZ-AM Remote Evaporator units consisting of thermal expansion valve, solenoid valve, sight glass and filter drier (sealed on Models 010 to 070, replaceable core on Models 075 to 130).

Electrical

Multi-Point Electrical Connection (AGZ 026B – 130B only)

Provides a power connection to each of the unit's two electrical circuits.

Disconnect Switch with Through-the-Door Handle

A factory or field installed option for service use, nonfused disconnect switch (mounted inside the power section of the control box) with a through-the-door handle is available with single and multi-point power supply except Model AGZ 034 with 208/230 volt power.

Phase Loss/Voltage Protection

(P/N 350015201) Phase loss with under/over voltage protection and multiple LED indication of fault type is available as a factory installed option to guard against compressor motor burnout.

Convenience Outlet (AGZ 026B to 130B only)

10.0 amp, 115 volt Ground Fault Circuit Interruption (GFCI) outlet located in control panel to provide power for servicing unit.

Ground Fault Protection (AGZ 026B to 130B only)

Protects equipment from damage from line-to-ground fault currents less than those required for conductor protection.

High Short Circuit Current Protection

Provides control panel protection against short circuit currents per following table:

Voltage	208	240	460	600
Current (kA)	120	100	65	25

Control Panel Exhaust Fan (AGZ 026B – 130B only)

Consists of an exhaust fan with rain hood, two inlet screens with filters, necessary controls and wiring to allow operation to 125°F. The fan is required under certain circumstances and included with the unit. See page 38 for further information. The option can be factory-installed or field-installed as a kit.

Product Specification

Specifications are available in MSWord format. Contact the local McQuay sales office.

SECTION 15XXX AIR-COOLED SCROLL COMPRESSOR CHILLERS AGZ 010AS-AGZ 130BS/BH

PART 1 - GENERAL

1.01 SUMMARY

Section includes design, performance criteria, refrigerants, controls, and installation requirements for air-cooled scroll compressor chillers.

1.02 REFERENCES

Comply with applicable Standards/Codes of ARI 550/590-98, ANSI/ASHRAE 15, ETL, cETL, NEC, and OSHA as adopted by the State.

Units shall meet the efficiency standards of ASHRAE Standard 90.1, October 2001.

1.03 SUBMITTALS

A. Submit shop drawings and product data in accordance with the specifications.

B. Submittals shall include the following:

1. Dimensioned plan and elevation view drawings, required clearances, and location of all field connections.
2. Summary of all auxiliary utility requirements, such as electricity, water, compressed air, etc. Summary shall indicate quality and quantity of each required utility.
3. Single-line schematic drawing of the power field hookup requirements, indicating all items that are furnished.
4. Schematic diagram of control system indicating points for field interface/connection.
5. Diagram shall fully delineate field and factory wiring.
6. Certification of factory-run test of chiller unit signed by company officer.
7. Installation manuals.

1.04 QUALITY ASSURANCE

A. Qualifications: Equipment manufacturer must specialize in the manufacture of the products specified and have five years experience with the type equipment and refrigerant offered.

B. Regulatory Requirements: Comply with the codes and standards specified.

C. Chiller manufacturer plant must be ISO9002 Registered.

1.05 DELIVERY AND HANDLING

- A. Chillers shall be delivered to the job site completely assembled and charged with refrigerant and oil by the manufacturer.
- B. Comply with the manufacturer's instructions for rigging and handling equipment.

1.06. WARRANTY

The refrigeration equipment manufacturer's guarantee shall be for a period of one year from date of equipment start-up but not more than 18 months from shipment. The guarantee shall provide for repair or replacement due to failure by material and workmanship that prove defective within the above period, excluding refrigerant.

1.07 MAINTENANCE

Maintenance of the chillers shall be the responsibility of the owner and performed in accordance with the manufacturer's instructions.

PART 2--PRODUCTS

2.01 ACCEPTABLE MANUFACTURERS

- A. McQuay International
- B. (Approved Equal)

2.02 UNIT DESCRIPTION

Provide and install as shown on the plans factory-assembled, factory-charged, and factory-tested air-cooled scroll compressor packaged chillers in the quantity specified. Each chiller shall consist of hermetic tandem or triple scroll compressor sets (total of two, four, or six compressors), direct expansion evaporator, air-cooled condenser section, microprocessor-based control system and all components necessary for controlled unit operation.

2.03 DESIGN REQUIREMENTS

- A. General: Provide a complete scroll compressor packaged chiller as specified herein and as shown on the drawings. The unit shall be in accordance with the standards referenced in section 1.02 and any local codes in effect.
- B. Performance: Refer to the schedule of performance on the drawings. The chiller shall be capable of stable operation to a minimum of 50 percent of full load without hot gas bypass. Performance shall be in accordance with ARI Standard 550/590.
- C. Acoustics: Sound pressure levels for the unit shall not exceed the following specified levels. The manufacturer shall provide the necessary sound treatment to meet these levels if required. Sound data shall be provided with the quotation. Test shall be in accordance with ARI Standard 370.

Octave Band

63	125	250	500	1000	2000	4000	8000	dBA
----	-----	-----	-----	------	------	------	------	-----

2.04 CHILLER COMPONENTS

A. Compressors: The compressors shall be sealed hermetic scroll type with crankcase oil heater and suction strainer. Compressor shall have a forced-feed lubrication system with a reversible oil pump and oil charge. The compressor motor shall be refrigerant gas cooled, high torque, hermetic induction type, two-pole, with inherent thermal protection on all three phases and shall be mounted on RIS vibration isolator pads.

B. Evaporators

Units up to 70 nominal tons:

The evaporator shall be a compact, high efficiency, single or dual circuit, brazed plate-to-plate type heat exchanger consisting of parallel stainless steel plates.

The evaporator shall be protected with an electric resistance heater and insulated with 3/4"(19mm) thick closed-cell polyurethane insulation. This combination shall provide freeze protection down to -20°F (-29°C) ambient air temperature.

The water-side working pressure shall be a minimum of 350 psig (2413 kPa). Vent and drain connections shall be provided in the inlet and outlet chilled water piping by the installing contractor. Evaporators shall be designed and constructed according to, and listed by, Underwriters Laboratories (UL).

Units over 70 tons:

The evaporator shall be direct expansion, shell-and-tube type with water flowing in the baffled shell side and refrigerant flowing through the tubes. Two independent refrigerant circuits within the evaporator serve the unit's dual refrigerant circuits.

The evaporator shall have a carbon steel shell and seamless high efficiency copper tubes roller expanded into a carbon steel tube sheet.

Refrigerant heads shall be carbon steel with multi-pass baffles to provide oil return and be removable to permit access to the tubes from either end. For water removal, 3/8" (10mm) vent and drain plugs are provided on the top and bottom of the shell.

The evaporator shall have an electric resistance heater and be insulated with 3/4" (19mm) thick vinyl nitrate polymer sheet insulation, protecting against water freeze-up at ambient air temperatures to -20°F (-29°C). An ambient air thermostat controls the heater cable.

The fitted and glued-in-place insulation shall have a K factor of at least 0.28 at 75°F (23°C).

The water side working pressure shall be 150 psig (1035 kPa). Each evaporator shall be designed, constructed, inspected, and stamped according to the requirements of the ASME Boiler and Pressure Vessel Code. Double thickness insulation is available as an option.

C. Condenser: The condenser coils shall consist of 3/8 inch (10mm) seamless copper tubes mechanically bonded into plate-type fins. The fins shall have full drawn collars to

completely cover the tubes. A subcooling coil shall be an integral part of the main condenser coil. Condenser fans shall be propeller type arranged for vertical air discharge and individually driven by direct-drive fan motors. They shall be equipped with a heavy-gauge fan guard. Fan motors shall be TEAO, three-phase, direct-drive, 1140 rpm.

- D. Refrigerant Circuit: The refrigerant circuit shall include a refrigerant filter-drier, sight glass with moisture indicator, liquid line solenoid valve (no exceptions), thermal expansion valve, and insulated suction line.
- E. Control System: A centrally located weatherproof control panel shall contain the field power connection points, control interlock terminals, and control system. Power and starting components shall include factory circuit breaker of fan motors and control circuit, individual contactors for each fan motor, solid-state compressor three-phase motor overload protection, inherent fan motor overload protection and unit power terminal blocks for connection to remote disconnect switch. Terminals shall also be provided for power supply to the evaporator heater circuit. Hinged access doors shall be lockable. Barrier panels or separate enclosures are required to protect against accidental contact with line voltage when accessing the control system.
- F. An advanced DDC microprocessor unit controller with a 4-line by 20-character liquid crystal display provides the operating and protection functions. The controller shall take pre-emptive limiting action in case of high discharge pressure or low evaporator pressure. The controller shall contain the following features as a minimum:

Equipment Protection

The unit shall be protected in two ways: (1) by alarms that shut the unit down and require manual reset to restore unit operation and (2) by limit alarms that reduce unit operation in response to some out-of-limit condition. Shut down alarms shall activate an alarm signal.

Shutdown Alarms

No evaporator water flow	Sensor failures
Low evaporator pressure	Evaporator freeze protection
High condenser pressure	Outside ambient temperature
Motor protection system	Phase voltage protection (Optional)

Limit Alarms

- Condenser pressure stage down, unloads unit at high discharge pressures
- Low ambient lockout, shuts off unit at low ambient temperatures
- Low evaporator pressure hold, holds stage #1 until pressure rises
- Low evaporator pressure unload, shuts off one compressor

Unit Enable Selection

Enables unit operation from either local keypad, digital input, or BAS

Unit Mode Selection

Selects standard cooling, ice, glycol, or test operation mode

Analog Inputs

Reset of leaving water temperature, 4-20 mA

Digital Inputs

- Unit off switch
- Remote start/stop

- Flow switch
- Ice mode switch, converts operation and setpoints for ice production
- Motor protection

Digital Outputs

- Shutdown alarm; field wired, activates on an alarm condition, off when alarm is cleared
- Evaporator pump; field wired, starts pump when unit is set to start

Condenser fan control

The unit controller shall provide control of condenser fans based on compressor discharge pressure.

Building Automation System (BAS) Interface

The following BAS protocols shall be supported:

- BACnet®
- LONTalk®
- Modbus®

2.05 OPTIONS AND ACCESSORIES

The following options are to be included:

- Hot gas bypass to allow unit operation to 10 percent of full load
- Low ambient head pressure control to 0°F (-17.8°C)
- Non-fused disconnect switch with through-the-door handle
- Aluminum fins shall be pre-coated with a phenolic epoxy coating with 1000 hour salt spray rating (ASTM B117-90)
- Copper fin condenser coils
- *ElectroFin*[™] baked epoxy coating providing 3000+ hour salt spray resistance (ASTM B117-90) and is applied to both the coil and the coil frames.
- Chilled water flow switch to be field mounted in the chilled water line and field wired to terminals in the control panel.
- Spring vibration isolators for field installation
- Rubber-in-shear vibration isolators for field installation
- Double evaporator insulation
- Compressor sound reduction package

PART 3 - EXECUTION

3.01 INSTALLATION

- Install in strict accordance with manufacturer's requirements, shop drawings, and contract documents.
- Adjust and level chiller in alignment on supports.
- Coordinate electrical installation with electrical contractor.
- Coordinate controls with control contractor.

3.02 START-UP

- Install proper charge of refrigerant and oil.
- Provide testing and starting of machine, and instruct the Owner in its proper operation and maintenance.

**AIR-COOLED SCROLL COMPRESSOR CHILLERS
WITH REMOTE EVAPORATOR
AGZ 010AM- AGZ 130BM/BB**

PART 1 - GENERAL

1.01 SUMMARY

Section includes design, performance criteria, refrigerants, controls, and installation requirements for air-cooled scroll compressor chillers.

1.02 REFERENCES

Comply with applicable Standards/Codes of ARI 550/590-98, ANSI/ASHRAE 15, ETL, cETL, ASME Section VIII, NEC, ASHRAE Standard 90.1, and OSHA as adopted by the State.

1.03 SUBMITTALS

A. Submit shop drawings and product data in accordance with the specifications.

B. Submittals shall include the following:

1. Dimensioned plan and elevation view drawings, required clearances, and location of all field connections.
2. Summary of all auxiliary utility requirements such as: electricity, water, compressed air, etc. Summary shall indicate quality and quantity of each required utility.
3. Single line schematic drawing of the power field hookup requirements, indicating all items that are furnished.
4. Schematic diagram of control system indicating points for field interface/connection.
5. Field installed refrigerant piping diagram with line sizes and refrigeration specialties shown.
6. Diagram shall fully delineate field and factory wiring.
7. Installation manuals.

1.04 QUALITY ASSURANCE

A. Qualifications: Equipment manufacturer must specialize in the manufacture of the products specified and have five years experience with the equipment and refrigerant offered.

B. Regulatory Requirements: Comply with the codes and standards specified.

C. Chiller manufacturer plant must be ISO9002 Registered.

1.05 DELIVERY AND HANDLING

A. Chillers shall be delivered to the job site completely assembled and charged with refrigerant and oil by the manufacturer.

B. Comply with the manufacturers instructions for rigging and handling equipment.

1.06. WARRANTY

The refrigeration equipment manufacturer’s warranty shall be for a period of one year from date of equipment start up but not more than 18 months from shipment. The warranty shall cover material and workmanship that prove defective within the above period and resultant loss of refrigerant.

1.07 MAINTENANCE

Maintenance of the chillers shall be the responsibility of the owner and performed in accordance with the manufacturer’s instructions.

PART 2--PRODUCTS

2.01 ACCEPTABLE MANUFACTURERS

- A. McQuay International
- B. (Approved Equal)

2.02 UNIT DESCRIPTION

Provide and install as shown on the air-cooled scroll compressor chiller systems in the quantity specified. Each system shall consist of hermetic tandem or triple scroll compressors, air-cooled condenser section, control system and all components necessary for controlled unit operation. A multi-circuit, direct expansion, insulated evaporator shall be provided for remote location and be installed and piped to the outdoor unit by the installing contractor.

2.03 DESIGN REQUIREMENTS

- A. General: Provide a complete scroll compressor chiller system consisting of an outdoor compressor-condenser section and a remote indoor evaporator as specified herein and as shown on the drawings. The unit shall be in accordance with the standards referenced in section 1.02 and any local codes in effect.
- B. Performance: Refer to the schedule of performance on the drawings. The chiller shall be able to operate to at least 25 percent of full load without hot gas bypass.
- C. Acoustics: Sound pressure levels for the unit shall not exceed the following specified levels. The manufacturer shall provide the necessary sound treatment to meet these levels if required. Sound data shall be provided with the quotation and be measured at 30 feet from the unit and one meter above the unit base line

Octave Band

63	125	250	500	1000	2000	4000	8000	dBA
----	-----	-----	-----	------	------	------	------	-----

2.04 CHILLER COMPONENTS

- A. Compressors: The compressors shall be two sets of tandem or triple hermetic scroll type compressors with discharge service valve, crankcase oil heater and suction strainer. Compressors shall have a forced feed lubrication system with a reversible oil pump and factory oil charge. The compressor motors shall be refrigerant gas cooled, high torque,

hermetic induction type, two-pole, with inherent thermal protection on all three phases and shall be mounted on RIS vibration isolator pads.

- B. Remote Evaporator: Units less than 75 ton in capacity shall have a direct expansion type brazed-plate evaporator with stainless steel plates brazed together with copper. It shall be insulated with 3/4 inch (19mm) closed cell polyurethane insulation and be heated with an electric heater to provide freeze protection to -20°F (-29°C) ambient temperature. Units 75 tons and above shall have a direct expansion, shell and tube with carbon steel shell and high efficiency copper tubes rolled into steel tube sheets. The refrigerant heads shall have multi-pass baffles to provide oil return and be removable to permit access to the tubes from either end. The shall be insulated with 3/4 inch (19mm) closed cell polymer insulation with a minimum K factor of 0.28 at 75°F (23°C) and be heated with an electric heater to provide freeze protection to -20°F (-29°C) ambient temperature. The refrigerant side working pressure shall be at least 225 psig (1552 kPa). The water side working pressure shall be at least 175 psig (1207 kPa). The evaporator must be designed, constructed, inspected, and stamped according to the ASME Code.
- C. Condenser: The condenser coils shall consist of 3/8 inch (10mm) seamless copper tubes mechanically bonded into plate type fins. The fins shall have full drawn collars to completely cover the tubes. A subcooling coil shall be an integral part of the main condenser coil. Condenser fans shall be propeller type arranged for vertical air discharge and individually driven by direct drive fan motors. Each fan shall be in its own compartment to eliminate cross flow of condenser air during fan cycling and shall be equipped with a heavy-gauge vinyl coated fan guard. Fan motors shall be weather protected, three-phase, direct-drive, 1140 rpm, TEAO type. External coils shall have wire mesh protective guards.
- D. Refrigerant Circuit: The refrigerant specialties shall be supplied by the unit manufacturer and include a liquid line shutoff valve, refrigerant filter-drier, sight glass with moisture indicator, liquid line solenoid valve, thermal expansion valve, and insulated suction line. The factory specialties, along with piping and insulation furnished by the installing contractor shall be field installed by the contractor.
- E. Control System: A centrally located weatherproof control panel shall contain the field power connection points, control interlock terminals, and control system. Power and starting components shall include factory fusing of fan motors and control circuit; individual contactors for each fan motor, solid-state three-phase motor overload protection, inherent fan motor overload protection and unit power terminal blocks for connection to remote disconnect switch. Terminals shall also be provided for power supply to the evaporator heater circuit. Hinged access doors shall be lockable. Barrier panels are required to protect against accidental contact with line voltage when accessing the control system. The operating and equipment protection controls shall be:

- F. An advanced DDC microprocessor unit controller with a 4-line by 20-character liquid crystal display provides the operating and protection functions. The controller shall take pre-emptive limiting action in case of high discharge pressure or low evaporator pressure. The controller shall contain the following features as a minimum:

Equipment Protection

The unit shall be protected in two ways: (1) by alarms that shut the unit down and require manual reset to restore unit operation and (2) by limit alarms that reduce unit operation in response to some out-of-limit condition. Shut down alarms shall activate an alarm signal.

Shutdown Alarms

No evaporator water flow	Sensor failures
Low evaporator pressure	Evaporator freeze protection
High condenser pressure	Outside ambient temperature
Motor protection system	Phase voltage protection (Optional)

Limit Alarms

- Condenser pressure stage down, unloads unit at high discharge pressures
- Low ambient lockout, shuts off unit at low ambient temperatures
- Low evaporator pressure hold, holds stage #1 until pressure rises
- Low evaporator pressure unload, shuts off one compressor

Unit Enable Selection

Enables unit operation from either local keypad, digital input, or BAS

Unit Mode Selection

Selects standard cooling, ice, glycol, or test operation mode

Analog Inputs

Reset of leaving water temperature, 4-20 mA

Digital Inputs

Unit off switch	Motor protection
Remote start/stop	Flow switch
Ice mode switch, converts operation and setpoints for ice production	

Digital Outputs

- Shutdown alarm; field wired, activates on an alarm condition, off when alarm is cleared
- Evaporator pump; field wired, starts pump when unit is set to start

Condenser fan control

The unit controller shall provide control of condenser fans based on compressor discharge pressure.

Building Automation System (BAS) Interface

The following BAS protocols shall be supported:

BACnet®

LONTalk®

Modbus®

- G. The unit base and coil supports shall be fabricated from heavy gauge steel and painted with powder coat paint. Incidental supports can be galvanized.

2.05 OPTIONS AND ACCESSORIES

The following options are to be included:

- Hot gas bypass, field piped, on all circuits
- Low ambient, variable speed, head pressure control to 0°F (-17.8°C)
- Copper fin condenser coils
- Coils with aluminum fin stock precoated with a corrosion resistant epoxy coating
- Aluminum coils with *ElectroFin*[™] (*Electrofin* is a trademark of Applied Surface Technology Inc.) baked epoxy coating for additional protection. This coating system shall provide 3000+ hour salt spray resistance (ASTM B117-90) and be applied to both the coil and the coil frame.
- Aluminum fin stock precoated with a phenolic epoxy coating and with a 1000 hour salt spray resistance (ASTM B117-90).
- Wire mesh guards for lower portion of the unit
- Chilled water flow switch to be field mounted in the chilled water line and field wired to terminals in the control panel
- Spring vibration isolators for field installation
- Factory installed nonfused disconnect switch, with through-the-door handle, mounted in the unit control panel
- Factory installed circuit breaker to provide unit short circuit protection
- Phase loss with under/over voltage protection and with LED indication of the fault type.

PART 3 - EXECUTION

3.01 INSTALLATION

- A. Install in strict accordance with manufacturer's requirements, shop drawings, and contract documents.
- B. Adjust and level chiller in alignment on supports.
- C. Coordinate electrical installation with electrical contractor.
- D. Coordinate controls with control contractor.
- E. Provide all appurtenances required to provide a fully operational and functional chiller.

3.02 START-UP

- A. Provide proper charge of refrigerant and oil.
- B. Provide testing, and starting of machine, and instruct the Owner in its proper operation and maintenance.

TM® The following are trademarks or registered trademarks of their respective companies: BACnet from ASHREA; LONMARK, Lon Talk and LONWORKS from Echelon Corporation; Compliant Scroll from Copeland Corporation, ElectroFin from AST ElectroFin Inc.; Modbus from Gould Inc.; FanTrol, MicroTech II, Protocol Selectability, and SpeedTrol from McQuay International.

This document contains the most current product information as of this printing. For the most up-to-date product information, please go to **www.mcquay.com**.

