

**GENERAL SPECIFICATIONS:**

- Maximum Flow: 350 GPM (No minimum flow requirement)
- Maximum Pressure: 125 PSI
- Maximum Temperature: 135 ° F
- Screen Surface Area 367 Sq. In.

**MATERIALS:**

- Housing: 304 Stainless standard (316 Stainless optional)
- Gasket: EPDM standard (other compounds available)
- Screen Mesh: 316 Stainless (1/4" perforated sheet backup)

**SCREEN OPTIONS:**

- Multiple screen mesh and perforated sheet sizes available. (See product catalog for samples)

**NOTES:**

- 1- Flush Port is available in larger sizes. Bottom Flush Port is also available.
- 2- Stainless Steel internals (Elbow and Riser Pipe) are also available.
- 3- Dimensions are for informational purposes only and are subject to change.

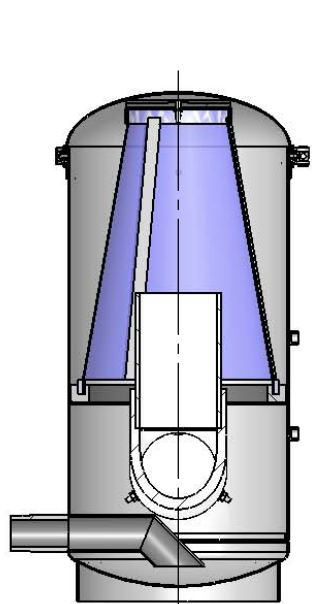

SECTION A-A

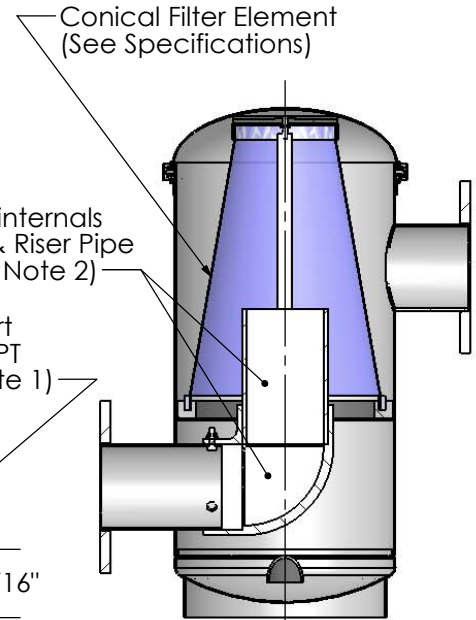
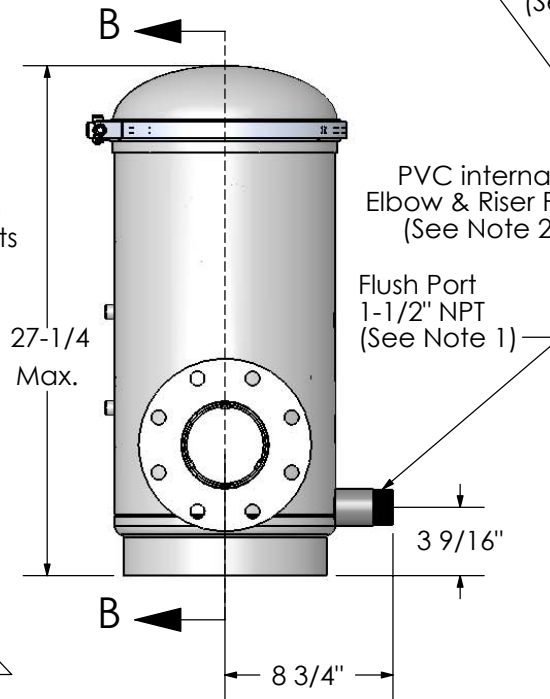
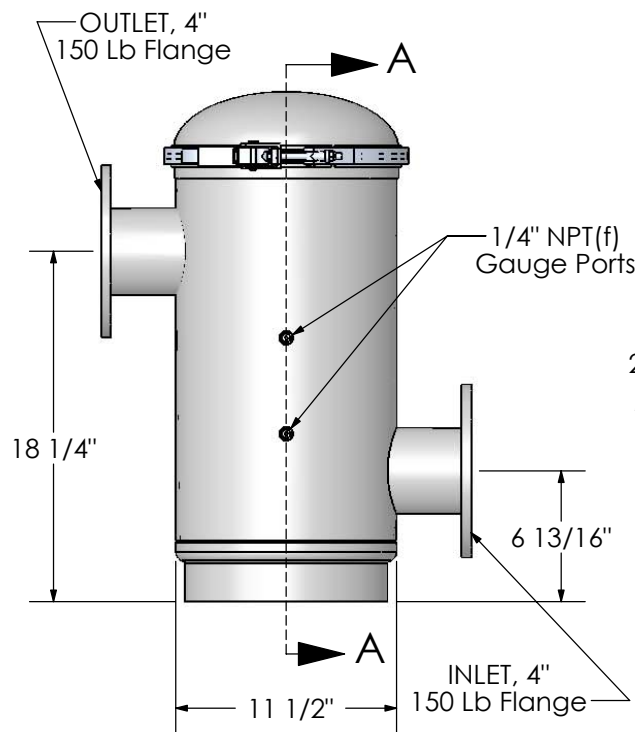

SECTION B-B

<b>PRODUCT SPECIFICATION</b>	DRAWN	J. Larsen	11/5/04	TITLE <b>Thompson Strainer MLS-4C</b>
	CHECKED			
	ENG APPR.			
	MKT APPR.			
	SHEET 1 OF 1			
<b>MILLER-LEAMAN INC.</b> 800 Orange Ave. Daytona Beach FL 32114				