

(6) .75 DIA HOLES (FOR 5/8-11*10" LG ANCHOR BOLTS)

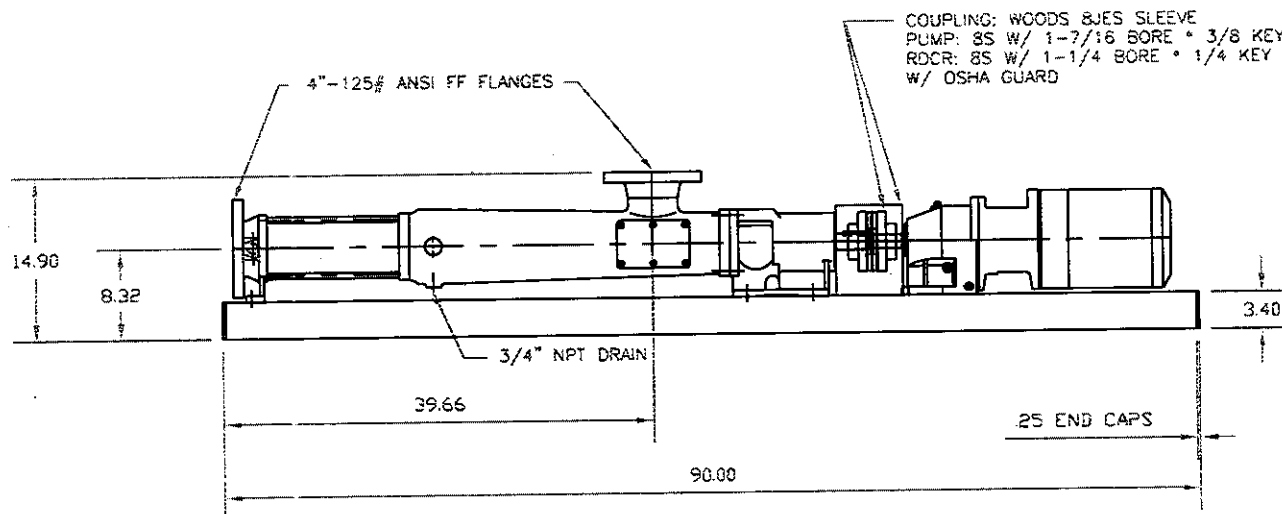

COUPLING: WOODS & JES SLEEVE
 PUMP: 8S W/ 1-7/16 BORE * 3/8 KEY
 RDCR: 8S W/ 1-1/4 BORE * 1/4 KEY
 W/ OSHA GUARD

- NOTES:
 A) DO NOT SCALE.
 B) TOLERANCE ± 0.25"
 C) ALL DIMENSIONS ARE IN INCHES.
 D) BASEPLATE FABRICATION-STRUCTURAL STEEL.

QUANTITY- ONE
 DESIGN DATA:
 CAPACITY- 70 GPM
 MATERIAL- OILS/GREASE IN WATER
 DISCHARGE PRESSURE- 10 PSI
 OPERATING SPEED- 300 RPM
 MATERIALS OF CONSTRUCTION:
 PUMP BODY- CAST IRON
 INTERNALS- MILD STEEL
 ROTOR- HCP TOOL STEEL
 STATOR- BUNA-N
 JOINTS- SM-PIN
 SHAFT SEAL- PACKING
 MOTOR DATA:
 TYPE- AC
 MFR- SIEMENS
 1800RPM 3 HP 1.0 SF
 3 PHASE 60 HERTZ 460 VOLTS
 CLASS F INSULATION FRAME 182TC
 ENCLOSURE- TEFC-XEXT INVERTER DUTY

REDUCER DATA:
 INPUT SPEED- 1750 RPM
 OUTPUT SPEED- 317 RPM
 RATIO- 5.42:1
 HP RATING- 5.1
 AGMA CLASS- B

0	RELEASE TO SALES/MFR	MAC	1/17/98	BHP
REV.	DESCRIPTION	BY	DATE	APPD.
DRAWN	JMAC	DATE	01/27/98	CHKD DATE
ENGR	APPD		B. H. PEART	DATE
ORDER NUMBER		SIZE	DRAWING NUMBER	SHY REV
A-646906-RL				
PROJECT		B31148710		
RALSTON PURINA				

JOB# 0301593498

PLOT SCALE: 1/12=1