

Vulcan Hart Gas Fully Jacketed Stationary Kettle-60 Gallon

Mfg: Vulcan Hart

Model: GL60E

Stock No. SPPP600.3a

Serial No. 14377

Vulcan Hart Gas Fully Jacketed Stationary Kettle-60 Gallon. Model: GL60E. S/N: 14377. NB: 7754. Natural gas-fired. Input: 0.44 hp per burner (15000 BTU/hr). (8) burners natural gas system with a total of 3.58 hp (120000 BTU/hr). Kettle features a sight glass level indicator and a sloped bottom. Inlets: (1) 3/4 in. dia. NPT (female), open top. Outlets: (1) 3/4 in. dia. NPT (female), (1) 3 in. dia. valve (tank discharge), (1) 10 in. L x 4 in. W (vapor). Overall dimensions: 55 in. diameter x 45 in. H.





GS, GL, GT SERIES GAS FULLY JACKETED KETTLE



ANSI/NSF Standard #4



GL40	40 gallons	151 liters
GS60	60 gallons	227 liters
GL80	80 gallons	303 liters
GT100	100 gallons	379 liters
GT125	125 gallons	473 liters
GT150	150 gallons	568 liters

SPECIFICATIONS:

Gas fully jacketed stationary kettle, Vulcan Model No. _____.
Kettle is mounted on 2" diameter legs with adjustable flanged feet. Cover to be stainless steel dome shaped with drop type handle and insulated knob. The dish shaped interior bottom is sloped to the front for a smooth product flow through a mounted, tapered, 2" plug type food product draw-off valve. Draw-off includes opening strainer. Graduated measuring rod. Furnished standard with a 15 PSI relief valve, vacuum relief valve, thermostat with a combination gas control valve and electronic ignition, low water cut-off control and a pressure limit switch and pressure gauge.

CSA design certified. Classified by U L to NSF Std. #4. Meets ASME code.

STANDARD FEATURES

- Kettle fully steam jacketed.
- Mounted on stainless steel 2" diameter legs with adjustable flange feet.
- Stainless steel dome shaped spring assist cover with drop type handle.
- Kettle interior bottom sloped to front for smooth product flow through a mounted, tapered, plug type food product draw-off valve of standard 2" diameter.
- Draw-off opening strainer.
- Graduated measuring rod.
- 15 PSI relief valve.
- Vacuum pressure relief valve.
- Thermostat with a combination gas control valve and electronic ignition.
- Low water cut-off control.
- Pressure limit switch and pressure gauge.
- Faucet bracket.
- One year limited parts and labor warranty.

OPTIONS

- 3" tapered, plug type draw-off valve in place of 2".
- Change in leg height to increase clearance under draw-off valve.
- Condensate ring on cover hinges.
- Swing drain collector.
- 316 stainless steel jacket liner
- Second year extended limited parts and labor warranty.

ACCESSORIES

- Stainless steel draw-off extension tube.
- (12") (18" double jointed) single pantry faucet.
- (12") (18" double jointed) double pantry faucet.
- Double pantry washdown hose with 16" add-on faucet with backflow preventer.
- Double pantry washdown hose with backflow preventer.
- Double pantry pot filler and backflow preventer.
- Rotating tri-basket assembly.
- Clean-up kit to include draw-off brush, clean-up brush with 36" handle and paddle scraper with 40" handle.
- 48" stainless steel whip.



GS, GL, GT SERIES

GAS FULLY JACKETED KETTLES

IMPORTANT:

1. A pressure regulator sized for this unit is included. Natural gas 8.0" W.C. Propane 10.5" W.C.
2. Gas line connecting to unit must be 3/4" or larger. If flexible connectors are used, the inside diameter must be at least the same as the 3/4" iron pipe and rated for the correct gas input.
3. Requires 120 volt, 60 Hz, 1 phase electrical connection. Furnished with 6' cord and 3 prong plug. 3 amp total draw.
4. An adequate ventilation system is required for commercial cooking equipment. Information may be obtained by writing to the National Fire Protection Association, Batterymarch Park, Quincy, MA 02269. When writing refer to NFPA No. 96.
5. These units are manufactured for installation in accordance with ANSZ223.1a (latest edition), National Fuel Gas Code. Copies may be obtained from the American Gas Association. 1515 Wilson Blvd., Arlington, VA 22209.
6. Equipment Clearance:

	Combustible	Non-Combustible
Rear	2"	0"
Right	0"	0"
Left	0"	0"

SERVICE CONNECTIONS:

- Gas Supply:** 3/4" NPT, 6" AFF, Volume per schedule.
- Electric Connection:** 120-1 Circuit, 0.3 KW, 16 AFF.
- Water:** Faucet location.

NOTE:

- Dimensions which locate the above connections have a tolerance of + or -3" (+ or -75 mm).
- Installation of backflow preventers, vacuum breakers and other specific code requirements is the responsibility of the owner and installer. It is the responsibility of the owner and installer to comply with local codes.
- Plastic drains are not recommended due to inherent limited temperatures of the plastic.
- This appliance is manufactured for commercial installation only and is not intended for home use.

BRIMFUL CAPACITIES:

Model	Gallons	Quarts	Liters	4 oz. svgs.
GL40	40	160	152	1280
GS60	60	240	227	1920
GL80	80	320	303	2560
GT100	100	400	379	3200
GT125	125	500	473	4000
GT150	150	600	568	4800

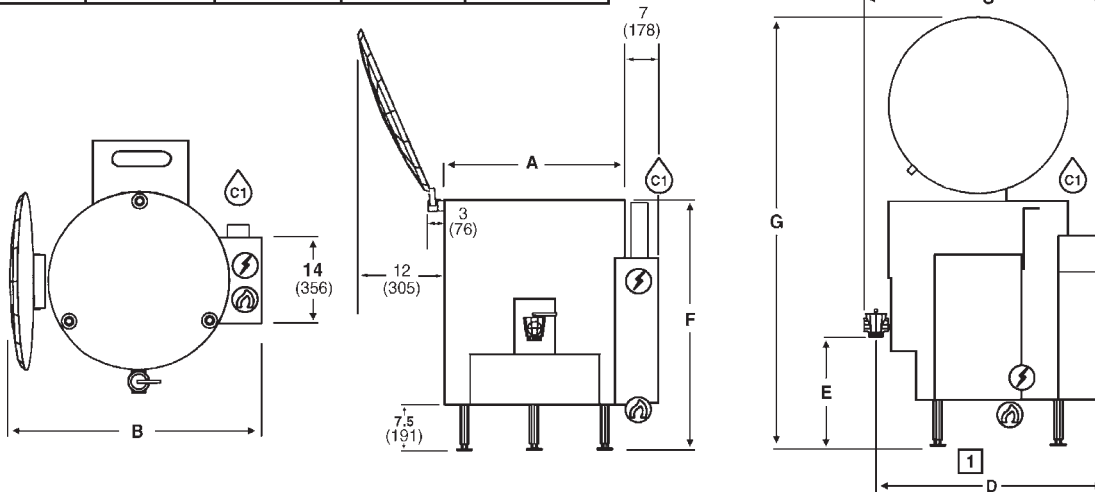

MODEL	CAPACITY	A	B	C	D	E	F	G	BTU/hr. INPUT
GL40	40 gal., 151 liters	29 (737)	48 (1219)	41 (1041)	38 (965)	14 (356)	40 (1016)	71 (1803)	105,000
GS60	60 gal., 227 liters	36 1/2 (927)	58 1/2 (1486)	48 (1219)	44 (1118)	17 (432)	39 (991)	78 (1981)	135,000
GL80	80 gal., 303 liters	36 1/2 (927)	58 1/2 (1486)	48 (1219)	44 (1118)	17 (432)	44 (1118)	83 (2108)	135,000
GT100	100 gal., 379 liters	36 1/2 (927)	58 1/2 (1486)	48 (1219)	44 (1118)	17 (432)	49 (1245)	88 (2235)	135,000
GT125	125 gal., 473 liters	36 1/2 (927)	58 1/2 (1486)	48 (1219)	44 (1118)	17 (432)	56 (1422)	95 (2413)	135,000
GT150	150 gal., 568 liters	36 1/2 (927)	58 1/2 (1486)	48 (1219)	44 (1118)	17 (432)	62 1/2 (1587)	101 (2565)	135,000

NOTE: In line with its policy to continually improve its products, Vulcan-Hart Company reserves the right to change materials and specifications without notice.