

NOTES

- THIS UNIT IS NOT DESIGNED TO SUPPORT ANY ADDITIONAL PIPING, VALVES, OR CONTROLS.
- THIS UNIT IS NOT DESIGNED FOR FORK TRUCK LIFTING.
- CAUTION: THIS UNIT IS SHIPPED WITH A NITROGEN PRESSURE OF 25 PSIG. EXERCISE CARE WHEN DISCHARGING PRESSURE.
- ORIFICE FEED 1.61 GPM @ 4.81 PSI
MINIMUM LIQUID FEED PRESSURE REQUIRED ABOVE COIL SUCTION PRESSURE AT LIQUID INLET

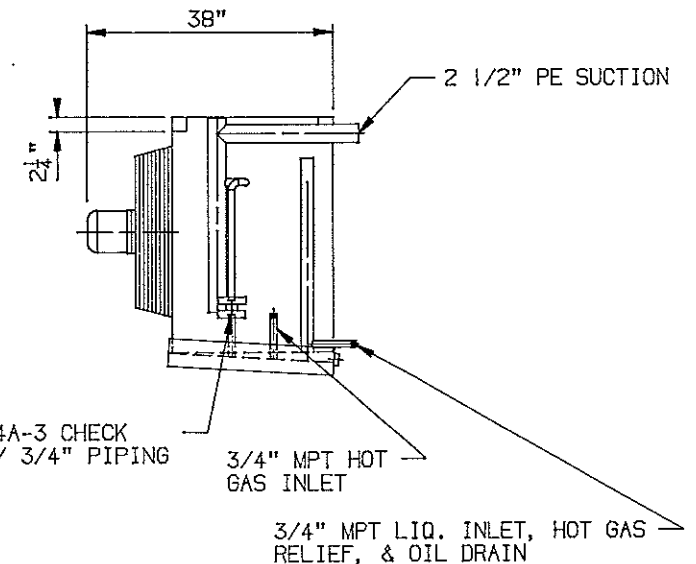
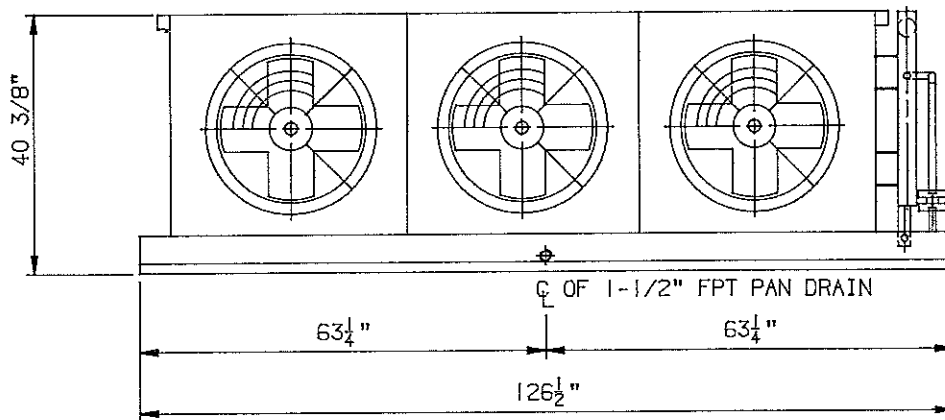
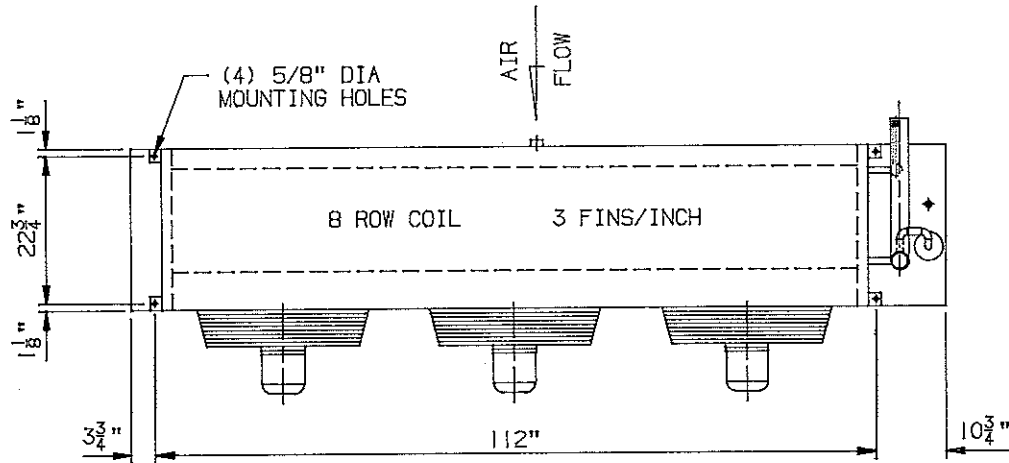

SO: 3279 | PAGE: 1 | QTY: 1 RH | UNIT WT: 2,320 LBS

UNIT DATA:
 CASING: GLV SHEET
 PAN: HOT DIPPED GLV AFTER FAB.
 PAN INSUL W/ GLV SHEET COVER
 HOT GAS PAN COIL UNDER INNER
 PAN W/ CHECK VALVE & PIPING

FAN DATA:
 16,225 CFM AIR @ 0" ESP
 (3) 24" DIR DRV PROP FANS
 (3) 1/2 HP TEAO 1140 RPM
 56 FR 230/460-3-60 W/ATO
 FAN MOTORS

PERFORMANCE DATA:
 9.2 TONS @ 10°F TD
 FEED: LR, BTM, AMMONIA
 HOT GAS DEFROST
 -20°F ROOM -30°F COIL
 -30°F LIO MECH PUMPED @ 3:l

GPX3-40L8-1110
 GENERAL PURPOSE UNIT COOLER
 FOR
 WESTERN ENGINEERS, INC.

ECN	DATE



DR: TTS
 DA: 7-19-93
 B-1692163