



VXI



Closed circuit cooling towers



Key benefits

- Reliable
- Quiet
- Compact

VXI characteristics

Counter flow, centrifugal fan, forced draft

Capacity range

up to 2615 kW

Maximum entering fluid temperature

82°C

Typical applications

- Small to medium HVAC and industrial applications
- Tight enclosures and installations requiring a single air inlet
- Indoor installations
- Sound critical installations
- High temperature industrial application
- Dry operation in winter time



Reliable operation guaranteed

- Since 1978, thousands globally installed, proving the VXI coolers **reliability**
- Fans, motor and drive system (V-belt) are located in the **dry air**, preventing moisture and condensation. No external moving parts, helping it withstand the toughest weather.
- Various corrosion-resistant materials, including the unique [Baltibond hybrid coating](#) for guaranteed long service life.
- **Optional extended surface coil** with steel fins for **dry operation**

Ideal for a quiet operation

- VXI closed circuit cooling towers include **quiet internal centrifugal fans** for minimal surrounding noise.
- Single-side air inlet, and a **quieter tower rear** for more noise-sensitive areas.
- Cut operation noise still further with factory-designed and tested [sound attenuators](#).

More compact

- Compact design for **confined spaces**,
- Single-side air inlet lets you install **next to solid walls**,
- Units housable **indoors** thanks to centrifugal fans allowing intake or discharge ductwork.

Reduced shipping, rigging and installation costs

- VXI units are factory-assembled. We ship larger models in 2 sections to reduce the size and weight of the heaviest section for **easy on-site assembly** with smaller cranes
- VXI offers high capacity and minimal operating weight. **Save on steel supports**, both underneath the equipment and in the building itself for rooftop installations.
- VXI-C models can be **container-shipped** (in 12' containers). Fan enclosures shippable loose in the tower bottom section for easy on-site assembly.

Interested in the VXI cooling tower for cooling your process fluid? Contact your local [BAC representative](#).

Downloads

- [VXI compilation pdf \(EN\)](#)
- [S - VXI \(EN\)](#)
- [M - VXI \(EN\)](#)
- [R - VXI \(EN\)](#)



VXI

Closed circuit cooling towers



Principle of operation

Warm process **fluid (1)** enters through a **heat exchange coil (2)** and gets water sprayed on by the **spray system (3)** at the top of the cooling tower. At the same time the **centrifugal fan (4)**, located at the bottom of the unit, blows ambient **air (5)** upwards through the tower. During operation, heat is transferred from the internal circuit coil to the water, and then to the atmosphere as a portion of the water that evaporates. The cooled down fluid then **exits the unit (6)**. The tower **sump (7)** or basin collects the remaining water. The spray water **pump (8)** recirculates the water up to the water spray system. The warm saturated **air (9)** leaves the tower through the drift **eliminators (10)**, which remove water droplets from the air.

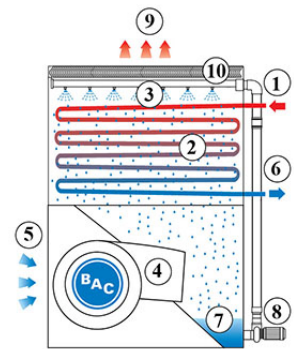

You want to use the VXI cooling tower to cool your process fluid?
Contact your local [BAC representative](#) for more information.



VXI

Closed circuit cooling towers



Construction details

1. Material options

- Heavy-gauge hot-dip galvanized steel is used for external unit steel panels and structural elements featuring [Baltiplus Corrosion Protection](#).
- The unique [Baltibond hybrid coating](#) is an optional extra. A hybrid polymer coating for longer service life, applied pre-assembly to all hot-dip galvanized steel components of the unit.
- Optional [stainless steel](#) panels and structural elements of type 304 or 316 for extreme applications.
- Or the economical alternative: a **water-contact stainless steel cold water basin**. Its key components and the basin itself are stainless steel. The rest is protected with the Baltibond hybrid coating.

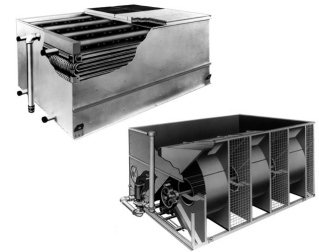

2. Heat transfer media

- Our heat transfer media is a **cooling coil**. Its thermal performance is proven during comprehensive [lab thermal performance tests](#), and it offers you unrivalled system efficiency.
- The coil is constructed of continuous length of prime surface steel, hot-dip galvanized after fabrication. Designed for maximum 10 bar operating pressure according to PED.
- All hot dip galvanized and stainless steel coils are delivered with BAC's **Internal Coil Corrosion Protection**, to ensure an optimal internal corrosion protection and guaranteed quality.
- Try our **optional extended surface coils** with selected rows, finned at 3 to 5 fins per inch and hot-dip galvanized after fabrication, for dry operation during winter time.
- **Optional stainless steel coils** are in type 304L or 316L.

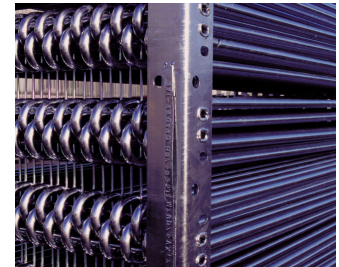

3. Air movement system

- With motor-driven centrifugal fan and a **V-belt drive**. You can easily remove the entire motor base for proper belt tensioning to ensure constantly correct belt alignment. Together with the **heavy duty fan shaft bearings** this guarantees optimal operational efficiency. Single- and multi speed **motors** available.
- **Centrifugal fan(s)** are forward-curved and nearly noiseless. Overcome external static pressure! Use [sound attenuators](#) and duct work etc. for air intake/discharge with no loss of thermal performance!
- **Our drift eliminators** come in UV-resistant plastic, which will not rot, decay or decompose and their performance is tested and **certified by Eurovent**. They are assembled in **easily handled and removable sections**, for optimal internal access.
- [Steel eliminators](#), protected with the unique [Baltibond hybrid coating](#), for optimal corrosion protection, are also available for specific applications.



4. Water distribution system

These consist of:

- A **header** and **spray branches** with wide non-clog plastic **nozzles**, secured by rubber **grommets**. You can easily remove, clean and flush both nozzles and spray branches.
- A cold water basin with:
 - **strainers** which are easy to lift out and the anti-vortexing device also helps stop trapped air
 - mechanical **make up**
 - circular **access door**
- Close coupled, bronze fitted centrifugal **spray pump** with totally enclosed fan cooled (TEFC) motor. Bleed line with metering valve installed from pump discharge to overflow.

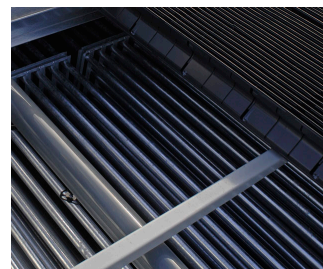

Like to know more about the VXi construction details? Contact your [local BAC representative](#).



VXI



Closed circuit cooling towers

Options and accessories

Below is a listing of the main VXI options and accessories. If your required option or accessory is not listed, look no further than your [local BAC representative](#).



Plume abatement coil

A finned discharge coil is installed in your cooling tower discharge and piped in series with the wet coil. This **reduces or eliminates plumes** and **extends the dry cooling capacity**. [Read more](#)



Sound attenuation

Reducing noise at air intake and discharge points brings us closer to silent cooling equipment.

- For **light** sound reduction, ideal for **suburban** requirements, try the XA sound attenuation.
- The **medium** sound reductions attained through XB sound attenuation are perfect for **residential** sound requirements
- For **heavy** sound reductions, XC sound attenuation is the best option, ideal for **rural** sound requirements. [Read more](#)

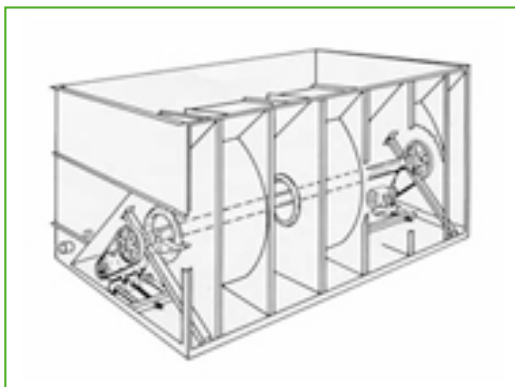

Baltiguard drive system

With this, operate your system like a dual-speed motor, but with standby reserve capacity **to cope with any failure.** [Read more](#)



Remote sump connection

The best way to **prevent a sump freezing** is to use the auxiliary remote variety within a heated area. Shutting off the circulating pump allows all the water in the water distribution, as well as that in suspension and the sump to drain freely to the auxiliary sump. [Read more](#)



Basin heater package

Thanks to our factory-installed heaters, the water stays at 4°C and **never freezes**, even during equipments downtime and however cold it gets outside. [Read more](#)



Electric water level control package

For perfectly precise water level control, replace the standard mechanical valve with our electrical water level controller. [Read more](#)



Platforms

To inspect and maintain from the top of the unit more **easily** and **safely**, platforms can be installed. [Read more](#)



Ladder, safety cage and handrail

A ladder, safety cage and handrails **all facilitate access to the top of the unit** and safe inspection of your cooling tower. [Read more](#)



Extended lubrication lines

Extended lubrication lines with easily accessible grease fittings can be used **to lubricate** fan shaft bearings. [Read more.](#)



Discharge hood

Discharge hoods **reduce the risk of re-circulation** in tight enclosures by increasing discharge air velocity, and can be used to elevate the unit discharge above adjacent walls to comply with layout guidelines. [Read more](#)



Positive closure dampers

Use positive closure dampers (PCD) to **minimize the heatloss due to convection** by preventing air flow through equipment that is shut down. [Read more](#)



Safety switch

Cuts power to motors **with safety in mind** during inspection or maintenance. [Read more](#)

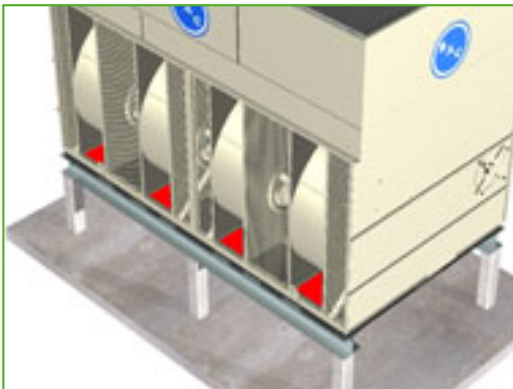

Solid bottom panels

You need factory-installed bottom panels when intake air is ducted to the unit. [Read more](#)



Standby pump

Install a standby **reserve spray pump** as failure backup! [Read more](#)



Water treatment equipment

Devices to control water treatment are needed to ensure proper **cooling tower water care**. Not only does this help protect the components and fill pack, controlling corrosion, scaling and fouling, it also avoids the proliferation of harmful bacteria, including **legionella**, in the recirculating water. [Read more](#)



Filter

Separators and media filters efficiently **remove suspended solids** in the recirculating water, reducing system cleaning costs and optimizing water treatment results. Filtration helps you keep the recirculating water clean. [Read more](#)



Sump sweeper piping

Sump sweeper piping **prevents sediment collecting in the cold water basin** of the unit. A complete piping system, including nozzles, is installed in the basin of the tower **for connection to side stream filtration** equipment. [Read more](#)



Clean out port

Clean out port **makes it easy to eliminate silt and sludge** from the cooling tower basin when cleaning and flushing the sump. [Read more](#)



Steel drift eliminators

Steel drift eliminators are more **robust** than plastic alternatives. [Read more](#)

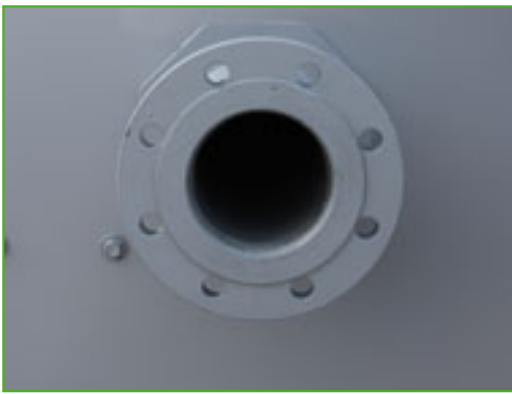

Flanges

Flanges facilitate **pipng connections** on-site. [Read more](#)



VXI



Closed circuit cooling towers

Engineering data

Remark: Do not use for construction. Refer to factory certified dimensions & weights. This page includes data current at time of publication, which should be reconfirmed at the time of purchase. In the interest of product improvement, specifications, weights and dimensions are subject to change without notice.

General notes

1. Make up, overflow, suction, drain connections and access door can be provided on side opposite to that shown; consult your BAC representative.
2. Unit height is indicative, for precise value refer to certified print.
3. Shipping/operating weights indicated are for units without accessories such as sound attenuators, discharge hoods, etc. Consult factory certified prints to obtain weight additions and the heaviest section to be lifted.
4. The drawings for units with only on spray pump show the standard "right hand" arrangement, which has the air inlet side on the right when facing the connection end.
5. Coil, overflow, make up and spray water connections are always located on the same end of the unit. For double pump units an additional set of coil connections and an additional overflow connection will be installed on the other end of the unit.
6. For indoor applications of closed circuit cooling towers, the room may be used as a plenum with ductwork is required, an enclosed fan section must be specified; consult your BAC Balticare representative for details.
7. Fan kW is at 0 Pa ESP. To operate against external static pressure up to 125 Pa, increase each fan motor one size.
8. On models VXI 9 to VXI 36 access doors are located at the opposite of the air inlet side, ensure sufficient space for entry when positioning these units. When flow rate on models VXI 27, VXI 36, VXI 50 exceeds 30l/s the quantity of coil connections will be double.
9. When flow rate on models VXI 70, VXI C72, VXI C108, VXI 95, VXI 145, VXI 180, VXI 144, VXI 215 exceeds 60 l/s the coil connections will be double when flow rate on models VXI 190, VXI 290, VXI 360, VXI 288 and VXI 430 exceeds 120l/s the quantity of coil connections will be double. Models VXI 9 through VXI 145 have one coil section and one fan motor, which can be switched on or off.
10. Models VXI-95, 144, 145, 180 and 215 have one coil section and one or two fan motors per coil casing section. Fan cycling results in only on-off operation. On these Units all fans need to operate simultaneously. Models vxi-190, 288, 290,360 and 430 have 2 coils casing section. Fan cycling results in only on-off operation. On these units all fans need to operate simultaneously per coil casing section. Multiple speed motors are available for additional steps of capacity control can be obtained with fan discharge dampers. Consult your local BAC representative.
11. For dry operation, standard motors must be increased one size to avoid motor overloading. Extended surface coils are available to vastly increase dry capacity without motor size increase. Consult your local BAC representative for selection and pricing.

Last update: 31 March 2018

VXI 9-36

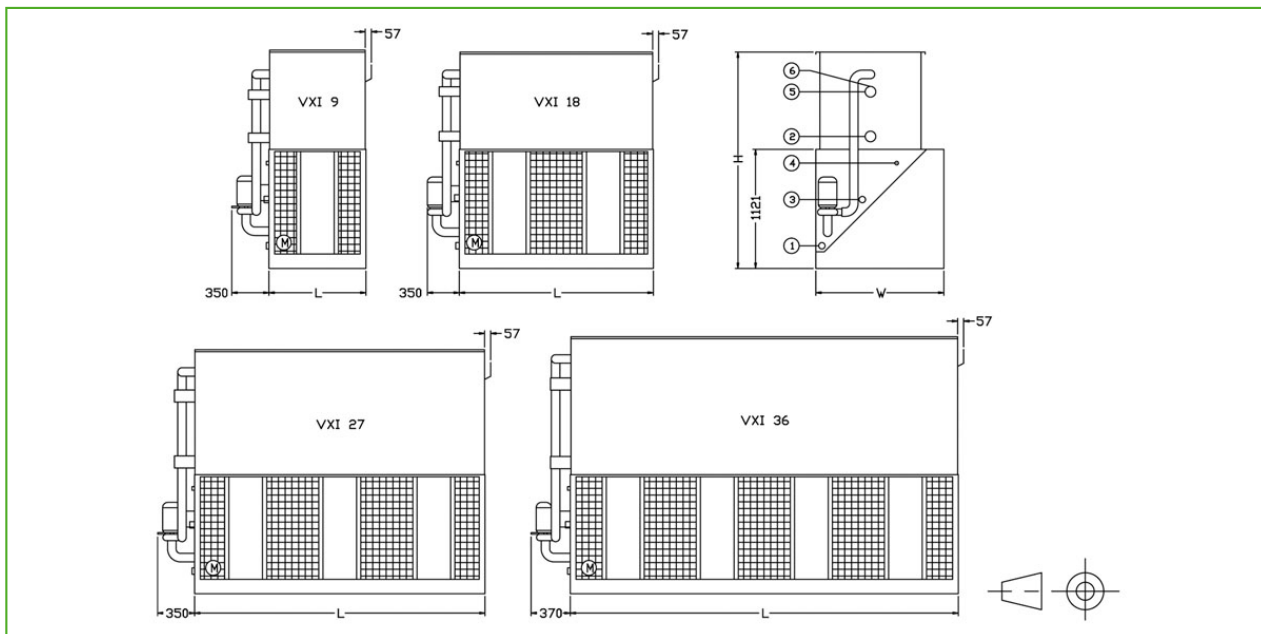

1. Drain ND50; 2. Outlet connection ND80 for VXI 9-X and ND100 for VXI 18-X, 27-X and 36-X; 3. Overflow ND50; 4. Make up ND25; 5. Inlet connection ND80 for VXI 9-X and ND100 for VXI 18-X, 27-X and 36-X; 6. Vent ND15; 7. Access door (not shown).



Model	Weights (kg)			Dimensions (mm)			Air Flow (m ³ /s)	Fan Motor (kW)	Water Flow (l/s)	Pump Motor (kW)	Coil Volume (L)
	Oper. Weight (kg)	Ship. Weight(kg)	Heaviest Section (kg)	L	W	H					
VXI 9-1	780	670	660	914	1207	2245	2.3	(1x) 1.5	2.2	(1x) 0.25	(1x) 75
VXI 9-2	870	760	480	914	1207	2467	2.2	(1x) 1.5	2.2	(1x) 0.25	(1x) 95
VXI 9-3	980	830	540	914	1207	2683	2.5	(1x) 2.2	2.2	(1x) 0.25	(1x) 115
VXI 18-0	1120	920	920	1829	1207	2035	4.6	(1x) 4.0	4.7	(1x) 0.37	(1x) 98
VXI 18-1	1270	1030	1030	1829	1207	2245	5.0	(1x) 4.0	4.7	(1x) 0.37	(1x) 140
VXI 18-2	1440	1160	700	1829	1207	2467	4.8	(1x) 4.0	4.7	(1x) 0.37	(1x) 182
VXI 18-3	1650	1330	860	1829	1207	2683	5.5	(1x) 5.5	4.7	(1x) 0.37	(1x) 224
VXI 27-1	1760	1320	1320	2737	1207	2343	7.6	(1x) 5.5	7.1	(1x) 0.75	(1x) 205
VXI 27-2	1990	1500	1000	2737	1207	2578	6.8	(1x) 5.5	7.1	(1x) 0.75	(1x) 269
VXI 27-3	2300	1730	1200	2737	1207	2813	7.1	(1x) 7.5	7.1	(1x) 0.75	(1x) 333
VXI 36-2	2300	1800	1200	3658	1207	2578	10.4	(1x) 7.5	9.5	(1x) 0.75	(1x) 356
VXI 36-3	2850	2080	1440	3658	1207	2813	10.9	(1x) 11.0	9.5	(1x) 0.75	(1x) 442



VXI



Closed circuit cooling towers

Engineering data

Remark: Do not use for construction. Refer to factory certified dimensions & weights. This page includes data current at time of publication, which should be reconfirmed at the time of purchase. In the interest of product improvement, specifications, weights and dimensions are subject to change without notice.

General notes

1. Make up, overflow, suction, drain connections and access door can be provided on side opposite to that shown; consult your BAC representative.
2. Unit height is indicative, for precise value refer to certified print.
3. Shipping/operating weights indicated are for units without accessories such as sound attenuators, discharge hoods, etc. Consult factory certified prints to obtain weight additions and the heaviest section to be lifted.
4. The drawings for units with only on spray pump show the standard "right hand" arrangement, which has the air inlet side on the right when facing the connection end.
5. Coil, overflow, make up and spray water connections are always located on the same end of the unit. For double pump units an additional set of coil connections and an additional overflow connection will be installed on the other end of the unit.
6. For indoor applications of closed circuit cooling towers, the room may be used as a plenum with ductwork is required, an enclosed fan section must be specified; consult your BAC Balticare representative for details.
7. Fan kW is at 0 Pa ESP. To operate against external static pressure up to 125 Pa, increase each fan motor one size.
8. On models VXI 9 to VXI 36 access doors are located at the opposite of the air inlet side, ensure sufficient space for entry when positioning these units.
When flow rate on models VXI 27, VXI 36, VXI 50 exceeds 30l/s the quantity of coil connections will be double.
9. When flow rate on models VXI 70, VXI C72, VXI C108, VXI 95, VXI 145, VXI 180, VXI 144, VXI 215 exceeds 60 l/s the coil connections will be double when flow rate on models VXI 190, VXI 290, VXI 360, VXI 288 and VXI 430 exceeds 120l/s the quantity of coil connections will be double.
Models VXI 9 through VXI 145 have one coil section and one fan motor, which can be switched on or off.
10. Models VXI-95, 144, 145, 180 and 215 have one coil section and one or two fan motors per coil casing section. Fan cycling results in only on-off operation. On these Units all fans need to operate simultaneously. Models vxi-190, 288, 290,360 and 430 have 2 coils casing section. Fan cycling results in only on-off operation. On these units all fans need to operate simultaneously per coil casing section. Multiple speed motors are available for additional steps of capacity control can be obtained with fan discharge dampers. Consult your local BAC representative.
11. For dry operation, standard motors must be increased one size to avoid motor overloading. Extended surface coils are available to vastly increase dry capacity without motor size increase. Consult your local BAC representative for selection and pricing.

Last update: 31 March 2018

VXI 50

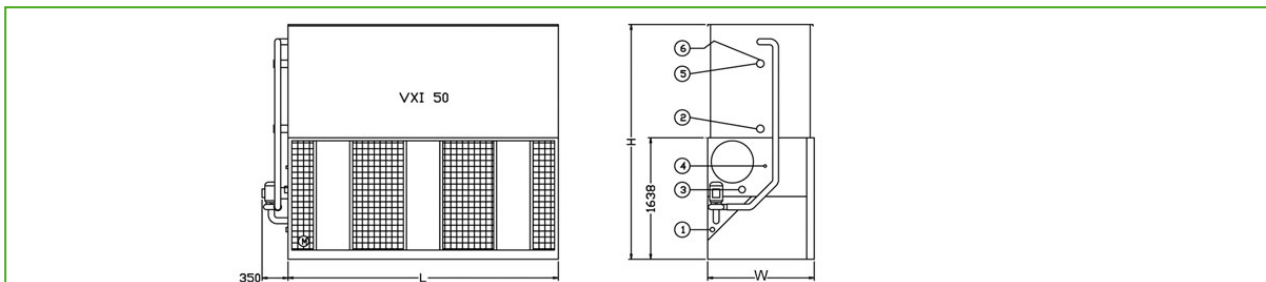

1. Drain ND50; Outlet connection ND100; 3. Overflow ND80; 4. Make up ND25; 5. Inlet connection ND100; 6. Vent ND15; 7. Access door.



Model	Weights (kg)			Dimensions (mm)			Air Flow (m ³ /s)	Fan Motor (kW)	Water Flow (l/s)	Pump Motor (kW)	Coil Volume (L)
	Oper. Weight (kg)	Ship. Weight(kg)	Heaviest Section (kg)	L	W	H					
VXI 50-2	3740	2670	1720	3645	1438	3093	14.6	(1x) 11.0	13.9	(1x) 1.5	(1x) 515
VXI 50-3	4280	2950	1980	3645	1438	3328	15.7	(1x) 11.0	13.9	(1x) 1.5	(1x) 638
VXI 50-4	4825	3255	2240	3645	1438	3563	16.9	(1x) 15.0	13.9	(1x) 1.5	(1x) 762



VXI



Closed circuit cooling towers

Engineering data

Remark: Do not use for construction. Refer to factory certified dimensions & weights. This page includes data current at time of publication, which should be reconfirmed at the time of purchase. In the interest of product improvement, specifications, weights and dimensions are subject to change without notice.

General notes

1. Make up, overflow, suction, drain connections and access door can be provided on side opposite to that shown; consult your BAC representative.
2. Unit height is indicative, for precise value refer to certified print.
3. Shipping/operating weights indicated are for units without accessories such as sound attenuators, discharge hoods, etc. Consult factory certified prints to obtain weight additions and the heaviest section to be lifted.
4. The drawings for units with only on spray pump show the standard "right hand" arrangement, which has the air inlet side on the right when facing the connection end.
5. Coil, overflow, make up and spray water connections are always located on the same end of the unit. For double pump units an additional set of coil connections and an additional overflow connection will be installed on the other end of the unit.
6. For indoor applications of closed circuit cooling towers, the room may be used as a plenum with ductwork is required, an enclosed fan section must be specified; consult your BAC Balticare representative for details.
7. Fan kW is at 0 Pa ESP. To operate against external static pressure up to 125 Pa, increase each fan motor one size.
8. On models VXI 9 to VXI 36 access doors are located at the opposite of the air inlet side, ensure sufficient space for entry when positioning these units. When flow rate on models VXI 27, VXI 36, VXI 50 exceeds 30l/s the quantity of coil connections will be double.
9. When flow rate on models VXI 70, VXI C72, VXI C108, VXI 95, VXI 145, VXI 180, VXI 144, VXI 215 exceeds 60 l/s the coil connections will be double when flow rate on models VXI 190, VXI 290, VXI 360, VXI 288 and VXI 430 exceeds 120l/s the quantity of coil connections will be double. Models VXI 9 through VXI 145 have one coil section and one fan motor, which can be switched on or off.
10. Models VXI-95, 144, 145, 180 and 215 have one coil section and one or two fan motors per coil casing section. Fan cycling results in only on-off operation. On these Units all fans need to operate simultaneously. Models vxi-190, 288, 290,360 and 430 have 2 coils casing section. Fan cycling results in only on-off operation. On these units all fans need to operate simultaneously per coil casing section. Multiple speed motors are available for additional steps of capacity control can be obtained with fan discharge dampers. Consult your local BAC representative.
11. For dry operation, standard motors must be increased one size to avoid motor overloading. Extended surface coils are available to vastly increase dry capacity without motor size increase. Consult your local BAC representative for selection and pricing.

Last update: 31 March 2018

VXI 95-145-190-290

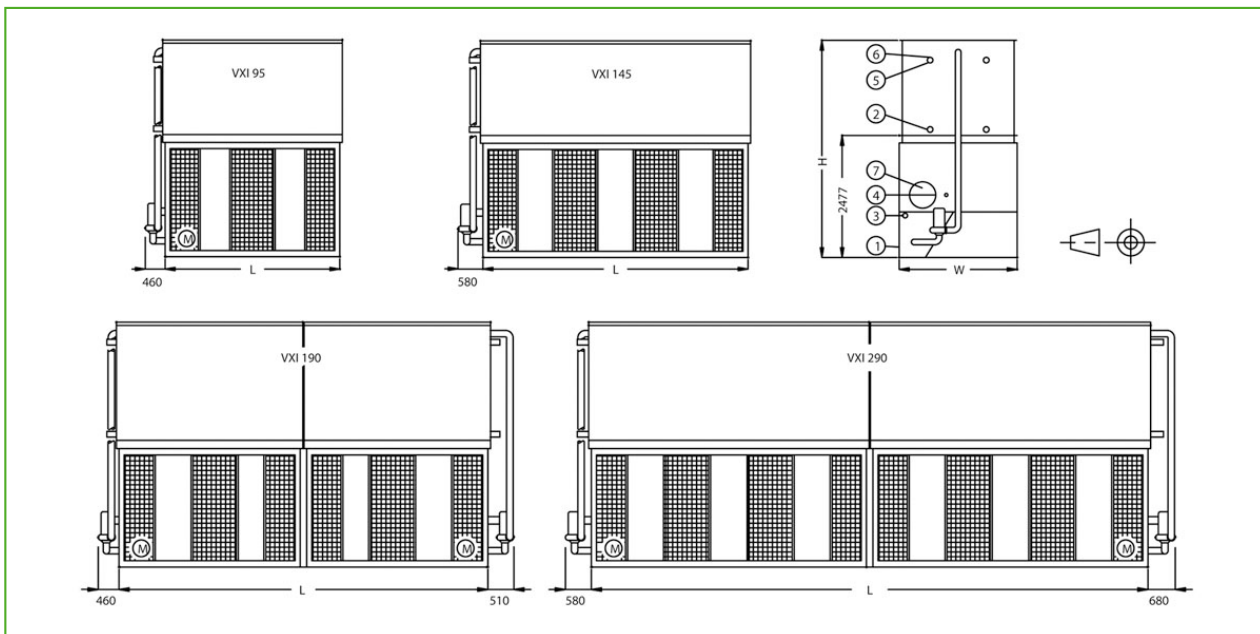

1. Drain ND50 (not shown); 2. Outlet Connection ND100; 3. Overflow ND80; 4. Make Up ND50; 5. Inlet Connection ND100; 6. Vent ND15; 7. Access Door.



Model	Weights (kg)			Dimensions (mm)			Air Flow (m ³ /s)	Fan Motor (kW)	Water Flow (l/s)	Pump Motor (kW)	Coil Volume (L)
	Oper. Weight (kg)	Ship. Weight(kg)	Heaviest Section (kg)	L	W	H					
VXI 95-2	7740	4990	3200	3550	2397	4013	27.6	(1x) 30.0	25.2	(1x) 2.2	(2x) 448
VXI 95-3	8630	5630	3850	3550	2397	4248	26.7	(1x) 30.0	25.2	(1x) 2.2	(2x) 556
VXI 95-4	9520	6180	4470	3550	2397	4483	26.2	(1x) 30.0	25.2	(1x) 2.2	(2x) 664
VXI 145-1	10100	6300	3780	5385	2397	3778	39.9	(1x) 37.0	38.5	(1x) 4.0	(2x) 506
VXI 145-2	11460	7280	4715	5385	2397	4013	38.6	(1x) 37.0	38.5	(1x) 4.0	(2x) 669
VXI 145-3	12810	8175	5710	5385	2397	4248	37.5	(1x) 37.0	38.5	(1x) 4.0	(2x) 832
VXI 145-4	14160	9260	6690	5385	2397	4483	36.6	(1x) 37.0	38.5	(1x) 4.0	(2x) 995
VXI 190-2	15400	9820	3390	7226	2397	4013	55.4	(2x) 30.0	50.4	(2x) 2.2	(4x) 448
VXI 190-3	17160	11100	3840	7226	2397	4248	53.4	(2x) 30.0	50.4	(2x) 2.2	(4x) 556
VXI 190-4	18920	12305	4470	7226	2397	4483	52.5	(2x) 30.0	50.4	(2x) 2.2	(4x) 664
VXI 290-1	20350	12680	5120	10903	2397	3778	79.5	(2x) 37.0	77.0	(2x) 4.0	(4x) 506
VXI 290-2	22980	14570	5120	10903	2397	4013	77.8	(2x) 37.0	77.0	(2x) 4.0	(4x) 669
VXI 290-3	25700	16550	5710	10903	2397	4248	75.0	(2x) 37.0	77.0	(2x) 4.0	(4x) 832
VXI 290-4	28420	18505	6690	10903	2397	4483	73.1	(2x) 37.0	77.0	(2x) 4.0	(4x) 995



VXI



Closed circuit cooling towers

Engineering data

Remark: Do not use for construction. Refer to factory certified dimensions & weights. This page includes data current at time of publication, which should be reconfirmed at the time of purchase. In the interest of product improvement, specifications, weights and dimensions are subject to change without notice.

General notes

1. Make up, overflow, suction, drain connections and access door can be provided on side opposite to that shown; consult your BAC representative.
2. Unit height is indicative, for precise value refer to certified print.
3. Shipping/operating weights indicated are for units without accessories such as sound attenuators, discharge hoods, etc. Consult factory certified prints to obtain weight additions and the heaviest section to be lifted.
4. The drawings for units with only on spray pump show the standard "right hand" arrangement, which has the air inlet side on the right when facing the connection end.
5. Coil, overflow, make up and spray water connections are always located on the same end of the unit. For double pump units an additional set of coil connections and an additional overflow connection will be installed on the other end of the unit.
6. For indoor applications of closed circuit cooling towers, the room may be used as a plenum with ductwork is required, an enclosed fan section must be specified; consult your BAC Balticare representative for details.
7. Fan kW is at 0 Pa ESP. To operate against external static pressure up to 125 Pa, increase each fan motor one size.
8. On models VXI 9 to VXI 36 access doors are located at the opposite of the air inlet side, ensure sufficient space for entry when positioning these units. When flow rate on models VXI 27, VXI 36, VXI 50 exceeds 30l/s the quantity of coil connections will be double.
9. When flow rate on models VXI 70, VXI C72, VXI C108, VXI 95, VXI 145, VXI 180, VXI 144, VXI 215 exceeds 60 l/s the coil connections will be double when flow rate on models VXI 190, VXI 290, VXI 360, VXI 288 and VXI 430 exceeds 120l/s the quantity of coil connections will be double. Models VXI 9 through VXI 145 have one coil section and one fan motor, which can be switched on or off.
10. Models VXI-95, 144, 145, 180 and 215 have one coil section and one or two fan motors per coil casing section. Fan cycling results in only on-off operation. On these Units all fans need to operate simultaneously. Models vxi-190, 288, 290,360 and 430 have 2 coils casing section. Fan cycling results in only on-off operation. On these units all fans need to operate simultaneously per coil casing section. Multiple speed motors are available for additional steps of capacity control can be obtained with fan discharge dampers. Consult your local BAC representative.
11. For dry operation, standard motors must be increased one size to avoid motor overloading. Extended surface coils are available to vastly increase dry capacity without motor size increase. Consult your local BAC representative for selection and pricing.

Last update: 31 March 2018

VXI 70

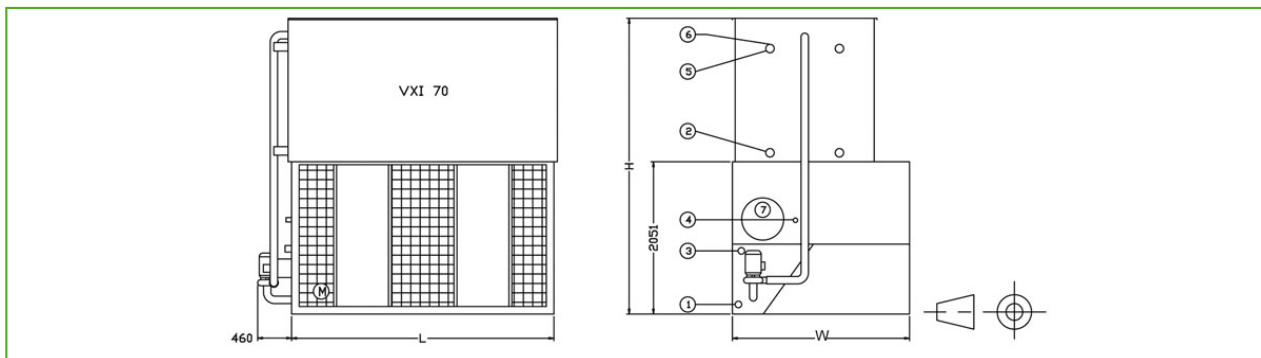

1. Drain ND50; 2. Outlet connection ND100; 3. Overflow ND80; 4. Make up ND50; Inlet connection ND100; 6. Vent ND15; 7. Access door.



Model	Weights (kg)			Dimensions (mm)			Air Flow (m ³ /s)	Fan Motor (kW)	Water Flow (l/s)	Pump Motor (kW)	Coil Volume (L)
	Oper. Weight (kg)	Ship. Weight(kg)	Heaviest Section (kg)	L	W	H					
VXI 70-2	6490	4250	2630	3550	2397	3585	20.8	(1x) 15.0	19.2	(1x) 2.2	(2x) 356
VXI 70-3	7190	4770	3150	3550	2397	3820	22.9	(1x) 18.5	19.2	(1x) 2.2	(2x) 442
VXI 70-4	8075	5315	3665	3550	2397	4056	22.2	(1x) 18.5	19.2	(1x) 2.2	(2x) 527



VXI



Closed circuit cooling towers

Engineering data

Remark: Do not use for construction. Refer to factory certified dimensions & weights. This page includes data current at time of publication, which should be reconfirmed at the time of purchase. In the interest of product improvement, specifications, weights and dimensions are subject to change without notice.

General notes

1. Make up, overflow, suction, drain connections and access door can be provided on side opposite to that shown; consult your BAC representative.
2. Unit height is indicative, for precise value refer to certified print.
3. Shipping/operating weights indicated are for units without accessories such as sound attenuators, discharge hoods, etc. Consult factory certified prints to obtain weight additions and the heaviest section to be lifted.
4. The drawings for units with only on spray pump show the standard "right hand" arrangement, which has the air inlet side on the right when facing the connection end.
5. Coil, overflow, make up and spray water connections are always located on the same end of the unit. For double pump units an additional set of coil connections and an additional overflow connection will be installed on the other end of the unit.
6. For indoor applications of closed circuit cooling towers, the room may be used as a plenum with ductwork is required, an enclosed fan section must be specified; consult your BAC Balticare representative for details.
7. Fan kW is at 0 Pa ESP. To operate against external static pressure up to 125 Pa, increase each fan motor one size.
8. On models VXI 9 to VXI 36 access doors are located at the opposite of the air inlet side, ensure sufficient space for entry when positioning these units. When flow rate on models VXI 27, VXI 36, VXI 50 exceeds 30l/s the quantity of coil connections will be double.
9. When flow rate on models VXI 70, VXI C72, VXI C108, VXI 95, VXI 145, VXI 180, VXI 144, VXI 215 exceeds 60 l/s the coil connections will be double when flow rate on models VXI 190, VXI 290, VXI 360, VXI 288 and VXI 430 exceeds 120l/s the quantity of coil connections will be double. Models VXI 9 through VXI 145 have one coil section and one fan motor, which can be switched on or off.
10. Models VXI-95, 144, 145, 180 and 215 have one coil section and one or two fan motors per coil casing section. Fan cycling results in only on-off operation. On these Units all fans need to operate simultaneously. Models vxi-190, 288, 290,360 and 430 have 2 coils casing section. Fan cycling results in only on-off operation. On these units all fans need to operate simultaneously per coil casing section. Multiple speed motors are available for additional steps of capacity control can be obtained with fan discharge dampers. Consult your local BAC representative.
11. For dry operation, standard motors must be increased one size to avoid motor overloading. Extended surface coils are available to vastly increase dry capacity without motor size increase. Consult your local BAC representative for selection and pricing.

Last update: 31 March 2018

VXI 180-360

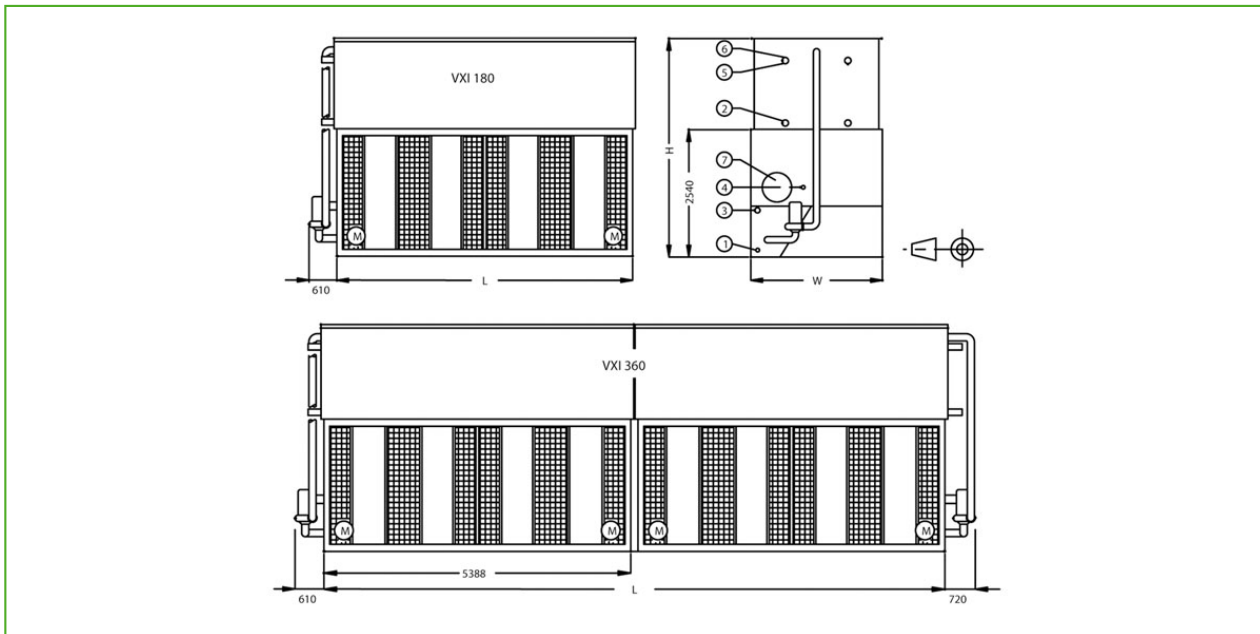

1. Drain ND50; 2. Outlet connection ND100; Overflow ND80; Make up ND50 for VXI 180-X and ND80 for VXI 360-X; 5. Inlet connection ND100; 6. Vent ND15; 7. Access door.



Model	Weights (kg)			Dimensions (mm)			Air Flow (m ³ /s)	Fan Motor (kW)	Water Flow (l/s)	Pump Motor (kW)	Coil Volume (L)
	Oper. Weight (kg)	Ship. Weight(kg)	Heaviest Section (kg)	L	W	H					
VXI 180-2	12970	8990	5810	5388	3000	4075	51.4	(2x) 18.5	46.7	(1x) 4.0	(2x) 847
VXI 180-3	14590	10200	7010	5388	3000	4310	50.0	(2x) 18.5	46.7	(1x) 4.0	(2x) 1052
VXI 180-4	16250	11530	8200	5388	3000	4545	52.0	(2x) 22.0	46.7	(1x) 4.0	(2x) 1258
VXI 360-2	25840	17940	5810	10903	3000	4075	102.9	(4x) 18.5	93.4	(2x) 4.0	(4x) 847
VXI 360-3	29090	20380	7010	10903	3000	4310	100.1	(4x) 18.5	93.4	(2x) 4.0	(4x) 1052
VXI 360-4	32500	23100	8200	10903	3000	4545	104.0	(4x) 22.0	93.4	(2x) 4.0	(4x) 1258



VXI



Closed circuit cooling towers

Engineering data

Remark: Do not use for construction. Refer to factory certified dimensions & weights. This page includes data current at time of publication, which should be reconfirmed at the time of purchase. In the interest of product improvement, specifications, weights and dimensions are subject to change without notice.

General notes

1. Make up, overflow, suction, drain connections and access door can be provided on side opposite to that shown; consult your BAC representative.
2. Unit height is indicative, for precise value refer to certified print.
3. Shipping/operating weights indicated are for units without accessories such as sound attenuators, discharge hoods, etc. Consult factory certified prints to obtain weight additions and the heaviest section to be lifted.
4. The drawings for units with only on spray pump show the standard "right hand" arrangement, which has the air inlet side on the right when facing the connection end.
5. Coil, overflow, make up and spray water connections are always located on the same end of the unit. For double pump units an additional set of coil connections and an additional overflow connection will be installed on the other end of the unit.
6. For indoor applications of closed circuit cooling towers, the room may be used as a plenum with ductwork is required, an enclosed fan section must be specified; consult your BAC Balticare representative for details.
7. Fan kW is at 0 Pa ESP. To operate against external static pressure up to 125 Pa, increase each fan motor one size.
8. On models VXI 9 to VXI 36 access doors are located at the opposite of the air inlet side, ensure sufficient space for entry when positioning these units. When flow rate on models VXI 27, VXI 36, VXI 50 exceeds 30l/s the quantity of coil connections will be double.
9. When flow rate on models VXI 70, VXI C72, VXI C108, VXI 95, VXI 145, VXI 180, VXI 144, VXI 215 exceeds 60 l/s the coil connections will be double when flow rate on models VXI 190, VXI 290, VXI 360, VXI 288 and VXI 430 exceeds 120l/s the quantity of coil connections will be double. Models VXI 9 through VXI 145 have one coil section and one fan motor, which can be switched on or off.
10. Models VXI-95, 144, 145, 180 and 215 have one coil section and one or two fan motors per coil casing section. Fan cycling results in only on-off operation. On these units all fans need to operate simultaneously. Models vxi-190, 288, 290,360 and 430 have 2 coils casing section. Fan cycling results in only on-off operation. On these units all fans need to operate simultaneously per coil casing section. Multiple speed motors are available for additional steps of capacity control can be obtained with fan discharge dampers. Consult your local BAC representative.
11. For dry operation, standard motors must be increased one size to avoid motor overloading. Extended surface coils are available to vastly increase dry capacity without motor size increase. Consult your local BAC representative for selection and pricing.

Last update: 31 March 2018

VXI 144-215-288-430

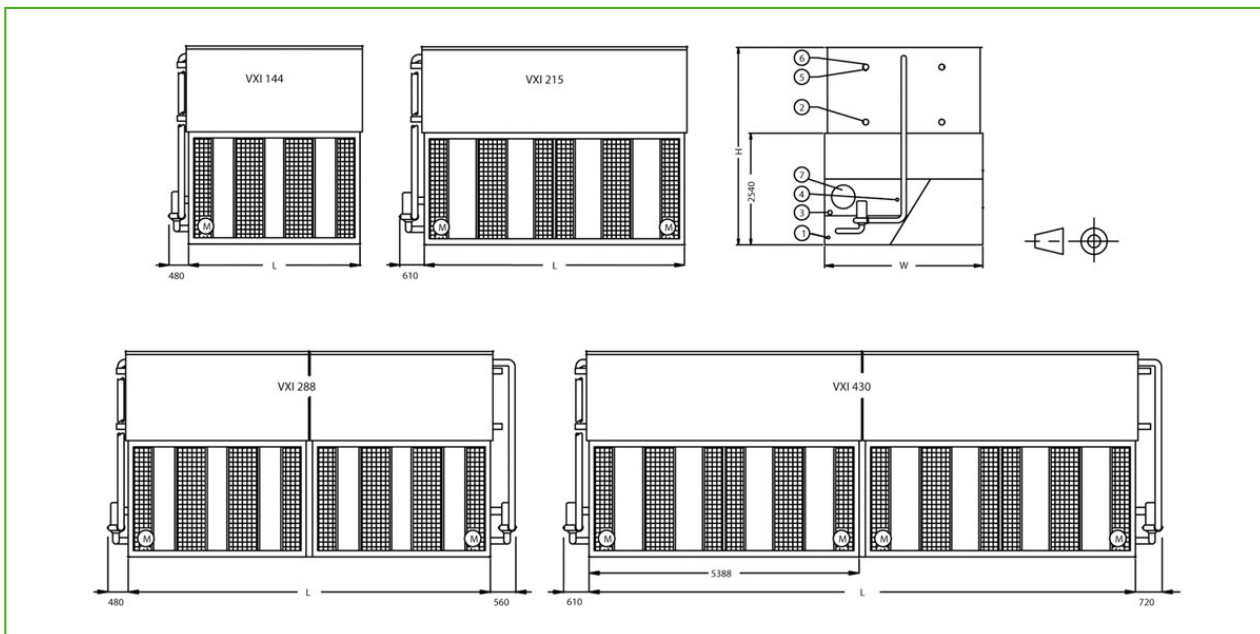

1. Drain ND50; 2. Outlet connection ND100; 3. Overflow ND80; Make up ND50 for VXi 144-x, 215-X, 288-X and ND80 for VXi 430-X; 5. Inlet connection ND100; 6. Vent ND15; 7. Access door.



Model	Weights (kg)			Dimensions (mm)			Air Flow (m ³ /s)	Fan Motor (kW)	Water Flow (l/s)	Pump Motor (kW)	Coil Volume (L)
	Oper. Weight (kg)	Ship. Weight(kg)	Heaviest Section (kg)	L	W	H					
VXI 144-2	12070	7270	4680	3550	3607	4075	38.6	(1x) 30.0	39.1	(1x) 4.0	(2x) 686
VXI 144-3	13390	8210	5610	3550	3607	4310	40.2	(1x) 37.0	39.1	(1x) 4.0	(2x) 851
VXI 144-4	14710	8470	6550	3550	3607	4545	39.4	(1x) 37.0	39.1	(1x) 4.0	(2x) 1015
VXI 215-1	15830	9130	5510	5388	3607	3840	59.4	(2x) 22.0	56.8	(1x) 4.0	(2x) 774
VXI 215-2	17730	10460	6900	5388	3607	4075	57.9	(2x) 22.0	56.8	(1x) 4.0	(2x) 1024
VXI 215-3	19730	12035	8310	5388	3607	4310	62.3	(2x) 30.0	56.8	(1x) 4.0	(2x) 1272
VXI 215-4	21690	13435	9710	5388	3607	4545	60.4	(2x) 30.0	56.8	(1x) 4.0	(2x) 1521
VXI 288-2	24230	14520	5280	7226	3607	4075	77.3	(2x) 30.0	78.2	(2x) 4.0	(4x) 686
VXI 288-3	26850	16520	5610	7226	3607	4310	80.0	(2x) 37.0	78.2	(2x) 4.0	(4x) 851
VXI 288-4	29540	18280	6550	7226	3607	4545	78.8	(2x) 37.0	78.2	(2x) 4.0	(4x) 1015
VXI 430-1	31750	18230	7210	10903	3607	3840	119.2	(4x) 22.0	113.6	(2x) 4.0	(4x) 774
VXI 430-2	35550	20890	7210	10903	3607	4075	115.9	(4x) 22.0	113.6	(2x) 4.0	(4x) 1024
VXI 430-3	39550	23770	8300	10903	3607	4310	124.6	(4x) 30.0	113.6	(2x) 4.0	(4x) 1272
VXI 430-4	43560	26845	9710	10903	3607	4545	120.7	(4x) 30.0	113.6	(2x) 4.0	(4x) 1521



VXI



Closed circuit cooling towers

Engineering data

Remark: Do not use for construction. Refer to factory certified dimensions & weights. This page includes data current at time of publication, which should be reconfirmed at the time of purchase. In the interest of product improvement, specifications, weights and dimensions are subject to change without notice.

General notes

1. Make up, overflow, suction, drain connections and access door can be provided on side opposite to that shown; consult your BAC representative.
2. Unit height is indicative, for precise value refer to certified print.
3. Shipping/operating weights indicated are for units without accessories such as sound attenuators, discharge hoods, etc. Consult factory certified prints to obtain weight additions and the heaviest section to be lifted.
4. The drawings for units with only on spray pump show the standard "right hand" arrangement, which has the air inlet side on the right when facing the connection end.
5. Coil, overflow, make up and spray water connections are always located on the same end of the unit. For double pump units an additional set of coil connections and an additional overflow connection will be installed on the other end of the unit.
6. For indoor applications of closed circuit cooling towers, the room may be used as a plenum with ductwork is required, an enclosed fan section must be specified; consult your BAC Balticare representative for details.
7. Fan kW is at 0 Pa ESP. To operate against external static pressure up to 125 Pa, increase each fan motor one size.
8. On models VXI 9 to VXI 36 access doors are located at the opposite of the air inlet side, ensure sufficient space for entry when positioning these units. When flow rate on models VXI 27, VXI 36, VXI 50 exceeds 30l/s the quantity of coil connections will be double.
9. When flow rate on models VXI 70, VXI C72, VXI C108, VXI 95, VXI 145, VXI 180, VXI 144, VXI 215 exceeds 60 l/s the coil connections will be double when flow rate on models VXI 190, VXI 290, VXI 360, VXI 288 and VXI 430 exceeds 120l/s the quantity of coil connections will be double. Models VXI 9 through VXI 145 have one coil section and one fan motor, which can be switched on or off.
10. Models VXI-95, 144, 145, 180 and 215 have one coil section and one or two fan motors per coil casing section. Fan cycling results in only on-off operation. On these Units all fans need to operate simultaneously. Models vxi-190, 288, 290,360 and 430 have 2 coils casing section. Fan cycling results in only on-off operation. On these units all fans need to operate simultaneously per coil casing section. Multiple speed motors are available for additional steps of capacity control can be obtained with fan discharge dampers. Consult your local BAC representative.
11. For dry operation, standard motors must be increased one size to avoid motor overloading. Extended surface coils are available to vastly increase dry capacity without motor size increase. Consult your local BAC representative for selection and pricing.

Last update: 31 March 2018

VXI C072-C108

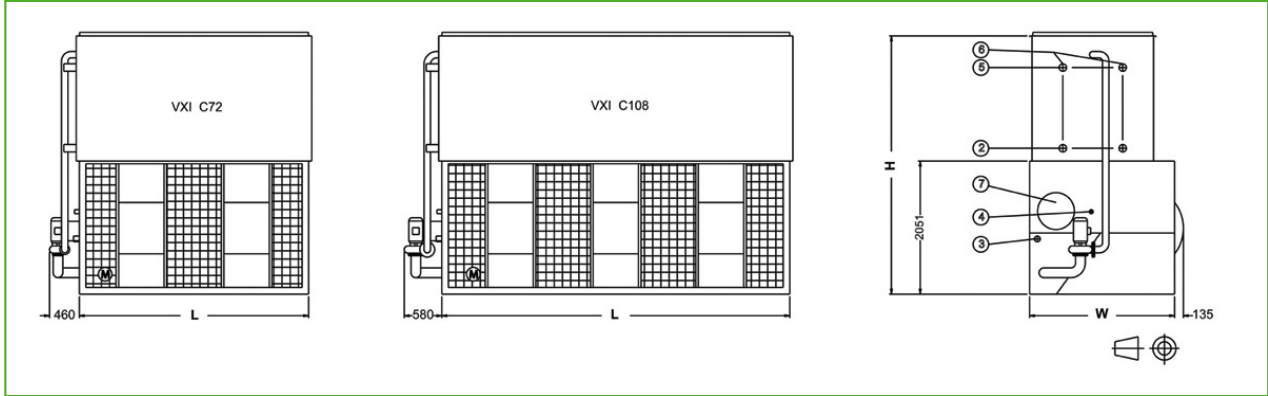

1. Drain ND xx; 2. Outlet connection NDxx; 3. Overflow NDxx; 4. Make up ND xx; 5. Inlet connection NDxx; 6. Vent NDxx; 7. Access door.



Model	Weights (kg)			Dimensions (mm)			Air Flow (m ³ /s)	Fan Motor (kW)	Water Flow (l/s)	Pump Motor (kW)	Coil Volume (L)
	Oper. Weight (kg)	Ship. Weight(kg)	Heaviest Section (kg)	L	W	H					
VXI C072-2	6490	4250	2630	3550	2245	3585	20.8	(1x) 15.0	19.2	(1x) 2.2	(2x) 356
VXI C072-3	7190	4770	3150	3550	2245	3820	22.9	(1x) 18.5	19.2	(1x) 2.2	(2x) 442
VXI C072-4	8075	5315	3665	3550	2245	4055	22.2	(1x) 18.5	19.2	(1x) 2.2	(2x) 527
VXI C108-2	9695	6145	3885	5385	2245	3585	33.5	(1x) 22.0	29.0	(1x) 4.0	(2x) 532
VXI C108-3	10630	6945	4685	5385	2245	3820	32.2	(1x) 22.0	29.0	(1x) 4.0	(2x) 661
VXI C108-4	11760	7830	5485	5385	2245	4055	31.1	(1x) 22.0	29.0	(1x) 4.0	(2x) 790



VXI



Closed circuit cooling towers

Engineering data

Remark: Do not use for construction. Refer to factory certified dimensions & weights. This page includes data current at time of publication, which should be reconfirmed at the time of purchase. In the interest of product improvement, specifications, weights and dimensions are subject to change without notice.

General notes

1. Make up, overflow, suction, drain connections and access door can be provided on side opposite to that shown; consult your BAC representative.
2. Unit height is indicative, for precise value refer to certified print.
3. Shipping/operating weights indicated are for units without accessories such as sound attenuators, discharge hoods, etc. Consult factory certified prints to obtain weight additions and the heaviest section to be lifted.
4. The drawings for units with only on spray pump show the standard "right hand" arrangement, which has the air inlet side on the right when facing the connection end.
5. Coil, overflow, make up and spray water connections are always located on the same end of the unit. For double pump units an additional set of coil connections and an additional overflow connection will be installed on the other end of the unit.
6. For indoor applications of closed circuit cooling towers, the room may be used as a plenum with ductwork is required, an enclosed fan section must be specified; consult your BAC Balticare representative for details.
7. Fan kW is at 0 Pa ESP. To operate against external static pressure up to 125 Pa, increase each fan motor one size.
8. On models VXI 9 to VXI 36 access doors are located at the opposite of the air inlet side, ensure sufficient space for entry when positioning these units. When flow rate on models VXI 27, VXI 36, VXI 50 exceeds 30l/s the quantity of coil connections will be double.
9. When flow rate on models VXI 70, VXI C72, VXI C108, VXI 95, VXI 145, VXI 180, VXI 144, VXI 215 exceeds 60 l/s the coil connections will be double when flow rate on models VXI 190, VXI 290, VXI 360, VXI 288 and VXI 430 exceeds 120l/s the quantity of coil connections will be double. Models VXI 9 through VXI 145 have one coil section and one fan motor, which can be switched on or off.
10. Models VXI-95, 144, 145, 180 and 215 have one coil section and one or two fan motors per coil casing section. Fan cycling results in only on-off operation. On these Units all fans need to operate simultaneously. Models vxi-190, 288, 290,360 and 430 have 2 coils casing section. Fan cycling results in only on-off operation. On these units all fans need to operate simultaneously per coil casing section. Multiple speed motors are available for additional steps of capacity control can be obtained with fan discharge dampers. Consult your local BAC representative.
11. For dry operation, standard motors must be increased one size to avoid motor overloading. Extended surface coils are available to vastly increase dry capacity without motor size increase. Consult your local BAC representative for selection and pricing.

Last update: 31 March 2018

Sound attenuation XA

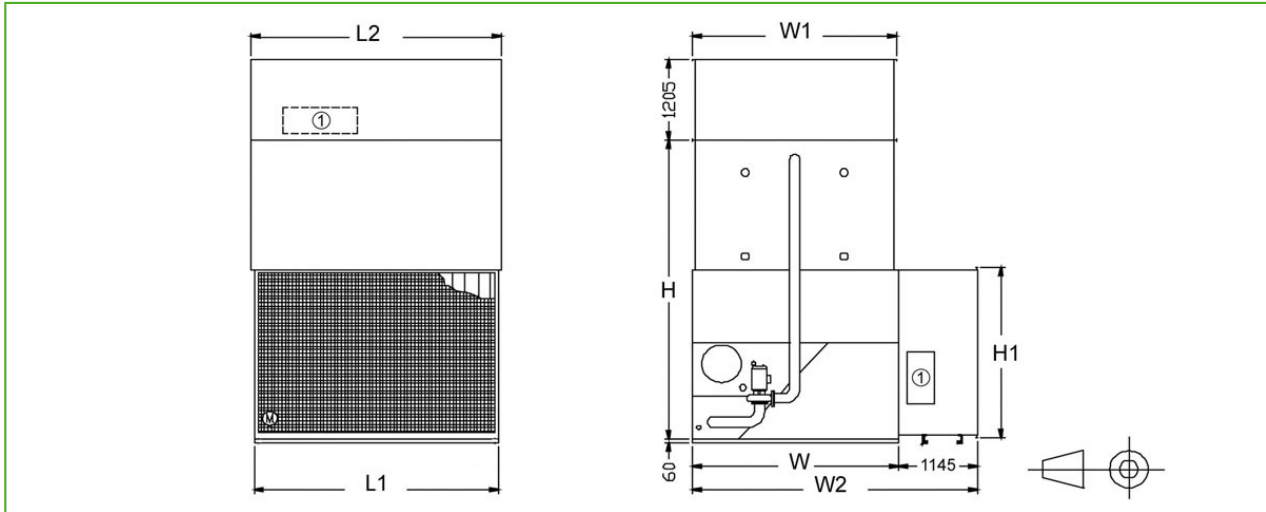

1. Access door: L = Unit Length; W = Unit Width; H = Unit Height (see Engineering Data).



Model	Unit + Atten # pieces shipped	# Access Doors		Dimensions (mm)					Weights (kg)			
		Dischar ge	Intake	W2	H1	W1	L1	L2	Intake	Solid Bottom	Dischar ge	Total
9-X	4 ¹	1	2	2352	1090	1030	890	902	110	30	130	270
18-X	4 ¹	1	2	2352	1090	1030	1800	1816	175	50	185	400
27-X	4	1	2	2352	1090	1030	2710	2731	230	70	280	580
36-X	4	1	2	2352	1090	1030	3635	3645	300	100	360	760
50-X	4	1	2	2583	1600	1420	3635	3645	380	120	440	940
70-X	4	1	2	3542	2070	1955	3525	3645	500	190	530	1120
C72-X	4	1	2	3390	2070	1955	3525	3645	500	190	530	1120
95-X	4	1	2	3542	2070	2365	3550	3645	500	190	660	1350
C108-X	4	2	2	3390	2070	1955	5365	5480	660	300	760	1720
145-X	4	2	2	3542	2070	2365	5385	5480	660	300	830	1970
190-X	7	2	2	3542	2070	2365	7200	7322	1000	380	1320	2700
290-X	7	4	2	3542	2070	2365	10885	10998	1320	600	1660	3580
180-X	4	2	2	4145	2560	2965	5365	5480	730	350	900	1980
360-X	7	4	2	4145	2560	2965	10730	10994	1460	700	1800	3960
144-X	4	1	2	2752	2560	3575	3525	3645	560	280	810	1650
215-X	4	2	2	4752	2560	3575	5365	5480	730	420	1020	2170
288-X	7	2	2	4752	2560	3575	7050	7322	1120	560	1620	3300
430-X	7	4	2	4752	2560	3575	10730	10994	1460	840	2040	4340



VXI



Closed circuit cooling towers

Engineering data

Remark: Do not use for construction. Refer to factory certified dimensions & weights. This page includes data current at time of publication, which should be reconfirmed at the time of purchase. In the interest of product improvement, specifications, weights and dimensions are subject to change without notice.

General notes

1. Make up, overflow, suction, drain connections and access door can be provided on side opposite to that shown; consult your BAC representative.
2. Unit height is indicative, for precise value refer to certified print.
3. Shipping/operating weights indicated are for units without accessories such as sound attenuators, discharge hoods, etc. Consult factory certified prints to obtain weight additions and the heaviest section to be lifted.
4. The drawings for units with only on spray pump show the standard "right hand" arrangement, which has the air inlet side on the right when facing the connection end.
5. Coil, overflow, make up and spray water connections are always located on the same end of the unit. For double pump units an additional set of coil connections and an additional overflow connection will be installed on the other end of the unit.
6. For indoor applications of closed circuit cooling towers, the room may be used as a plenum with ductwork is required, an enclosed fan section must be specified; consult your BAC Balticare representative for details.
7. Fan kW is at 0 Pa ESP. To operate against external static pressure up to 125 Pa, increase each fan motor one size.
8. On models VXI 9 to VXI 36 access doors are located at the opposite of the air inlet side, ensure sufficient space for entry when positioning these units. When flow rate on models VXI 27, VXI 36, VXI 50 exceeds 30l/s the quantity of coil connections will be double.
9. When flow rate on models VXI 70, VXI C72, VXI C108, VXI 95, VXI 145, VXI 180, VXI 144, VXI 215 exceeds 60 l/s the coil connections will be double when flow rate on models VXI 190, VXI 290, VXI 360, VXI 288 and VXI 430 exceeds 120l/s the quantity of coil connections will be double. Models VXI 9 through VXI 145 have one coil section and one fan motor, which can be switched on or off.
10. Models VXI-95, 144, 145, 180 and 215 have one coil section and one or two fan motors per coil casing section. Fan cycling results in only on-off operation. On these Units all fans need to operate simultaneously. Models vxi-190, 288, 290,360 and 430 have 2 coils casing section. Fan cycling results in only on-off operation. On these units all fans need to operate simultaneously per coil casing section. Multiple speed motors are available for additional steps of capacity control can be obtained with fan discharge dampers. Consult your local BAC representative.
11. For dry operation, standard motors must be increased one size to avoid motor overloading. Extended surface coils are available to vastly increase dry capacity without motor size increase. Consult your local BAC representative for selection and pricing.

Last update: 31 March 2018

Sound attenuation XB

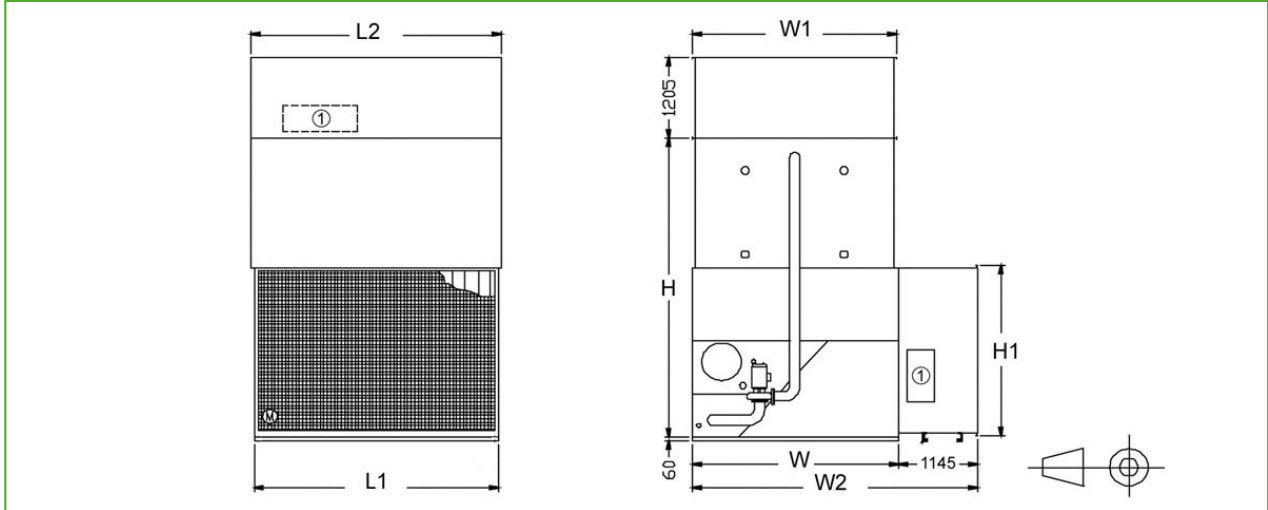

1. Access door; L = Unit Length; W = Unit Width; H = Unit Height (see Engineering Data).



Model	Unit + Atten # pieces shipped	# Access Doors		Dimensions (mm)					Weights (kg)			
		Dischar ge	Intake	W2	H1	W1	L1	L2	Intake	Solid Bottom	Dischar ge	Total
9-X	4 ¹	1	2	2352	1090	1030	890	902	130	30	150	310
18-X	4 ¹	1	2	2352	1090	1030	1800	1816	220	50	220	490
27-X	4	1	2	2352	1090	1030	2710	2731	300	70	350	720
36-X	4	1	2	2352	1090	1030	3635	3645	370	100	420	890
50-X	4	1	2	2583	1600	1420	3635	3645	480	120	520	1120
70-X	4	1	2	3542	2070	1955	3525	3645	630	190	650	1220
C72-X	4	1	2	3390	2070	1955	3525	3645	630	190	650	1220
95-X	4	1	2	3542	2070	2365	3550	3645	630	190	800	1620
C108-X	4	2	2	3390	2070	1955	5365	5840	860	300	970	2130
145-X	4	2	2	3542	2070	2365	5385	5480	860	300	1090	2250
190-X	7	2	2	3542	2070	2365	7200	7322	1260	380	1600	3240
290-X	7	4	2	3542	2070	2365	10885	10998	1720	600	2180	4500
180-X	4	2	2	4145	2560	2965	5365	5480	980	350	1210	2540
360-X	7	4	2	4145	2560	2965	10730	10994	1960	700	2420	5080
144-X	4	1	2	2752	2650	3575	3525	3645	710	280	1030	2020
215-X	4	2	2	4752	2560	3575	5365	5480	980	420	1410	2810
288-X	7	2	2	4752	2560	3575	7050	7322	1420	560	2060	4040
430-X	7	4	2	4752	2560	3575	10730	10994	1960	840	2820	5620



VXI



Closed circuit cooling towers

Engineering data

Remark: Do not use for construction. Refer to factory certified dimensions & weights. This page includes data current at time of publication, which should be reconfirmed at the time of purchase. In the interest of product improvement, specifications, weights and dimensions are subject to change without notice.

General notes

1. Make up, overflow, suction, drain connections and access door can be provided on side opposite to that shown; consult your BAC representative.
2. Unit height is indicative, for precise value refer to certified print.
3. Shipping/operating weights indicated are for units without accessories such as sound attenuators, discharge hoods, etc. Consult factory certified prints to obtain weight additions and the heaviest section to be lifted.
4. The drawings for units with only on spray pump show the standard "right hand" arrangement, which has the air inlet side on the right when facing the connection end.
5. Coil, overflow, make up and spray water connections are always located on the same end of the unit. For double pump units an additional set of coil connections and an additional overflow connection will be installed on the other end of the unit.
6. For indoor applications of closed circuit cooling towers, the room may be used as a plenum with ductwork is required, an enclosed fan section must be specified; consult your BAC Balticare representative for details.
7. Fan kW is at 0 Pa ESP. To operate against external static pressure up to 125 Pa, increase each fan motor one size.
8. On models VXI 9 to VXI 36 access doors are located at the opposite of the air inlet side, ensure sufficient space for entry when positioning these units. When flow rate on models VXI 27, VXI 36, VXI 50 exceeds 30l/s the quantity of coil connections will be double.
9. When flow rate on models VXI 70, VXI C72, VXI C108, VXI 95, VXI 145, VXI 180, VXI 144, VXI 215 exceeds 60 l/s the coil connections will be double when flow rate on models VXI 190, VXI 290, VXI 360, VXI 288 and VXI 430 exceeds 120l/s the quantity of coil connections will be double. Models VXI 9 through VXI 145 have one coil section and one fan motor, which can be switched on or off.
10. Models VXI-95, 144, 145, 180 and 215 have one coil section and one or two fan motors per coil casing section. Fan cycling results in only on-off operation. On these Units all fans need to operate simultaneously. Models vxi-190, 288, 290,360 and 430 have 2 coils casing section. Fan cycling results in only on-off operation. On these units all fans need to operate simultaneously per coil casing section. Multiple speed motors are available for additional steps of capacity control can be obtained with fan discharge dampers. Consult your local BAC representative.
11. For dry operation, standard motors must be increased one size to avoid motor overloading. Extended surface coils are available to vastly increase dry capacity without motor size increase. Consult your local BAC representative for selection and pricing.

Last update: 31 March 2018

Sound attenuation XC

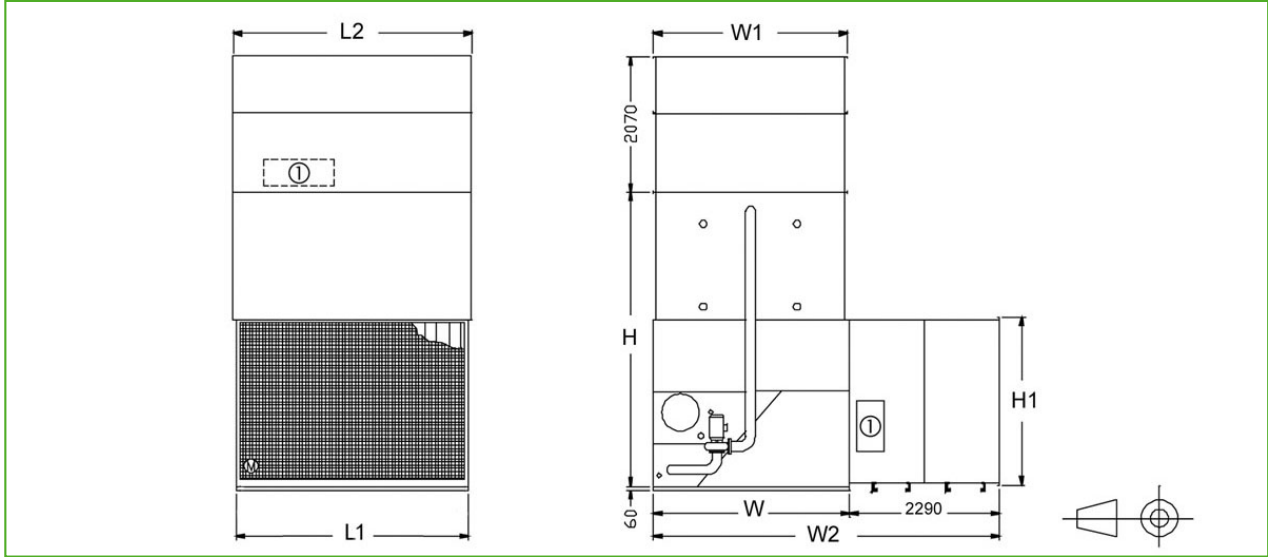

1. Acces door; L = Unit Length; W = Unit Width; H = Unit Height (see Engineering Data).



Model	Unit + Atten # pieces shipped	# Access Doors		Dimensions (mm)					Weights (kg)			
		Dischar ge	Intake	W2	H1	W1	L1	L2	Intake	Solid Bottom	Dischar ge	Total
9-X	4 ¹	1	2	N.A.	1090	1030	890	902	N.A.	30	N.A.	N.A.
18-X	4 ¹	1	2	N.A.	1090	1030	1800	1816	N.A.	50	N.A.	N.A.
27-X	4	1	2	N.A.	1090	1030	2710	2731	N.A.	70	N.A.	N.A.
36-X	4	1	2	N.A.	1090	1030	3635	3645	830	100	N.A.	N.A.
50-X	4	1	2	3728	1600	1420	3635	3645	1080	120	1070	2270
70-X	4	1	2	4687	2070	1955	3525	3645	1420	190	1330	2940
C72-X	4	1	2	4535	2070	1955	3525	3645	1420	190	1330	2940
95-X	4	1	2	4687	2070	2365	3550	3645	1420	190	1640	3250
C108- X	4	2	2	4535	2070	1955	5365	5480	1970	300	1980	4250
145-X	4	2	2	4687	2070	2365	5385	5480	1970	300	2240	4510
190-X	7	2	2	4687	2070	2365	7200	7322	2840	380	3280	6500
290-X	7	4	2	4687	2070	2365	10885	10998	3940	600	4480	9020
180-X	4	2	2	5290	2560	2965	5365	5480	2240	350	2490	5080
360-X	7	4	2	5290	2560	2965	10730	10994	4480	700	4980	10160
144-X	4	1	2	5897	2560	3575	3525	3645	1620	280	2130	4030
215-X	4	2	2	5897	2560	3575	5365	5480	2240	420	2920	5580
288-X	7	2	2	5897	2560	3575	7050	7322	3240	560	4260	8060
430-X	7	4	2	5897	2560	3575	10730	10994	4480	840	5840	11160