



BY JOHNSON CONTROLS

Form 070.500-SPC (JAN 2011)

SPECIFICATIONS

File: EQUIPMENT MANUAL - Section 70
Replaces: 070-500 SPC (MAY 2010)
Dist: 10

ROTARY SCREW COMPRESSORS

Models TDSH / PDSH 163 through 408

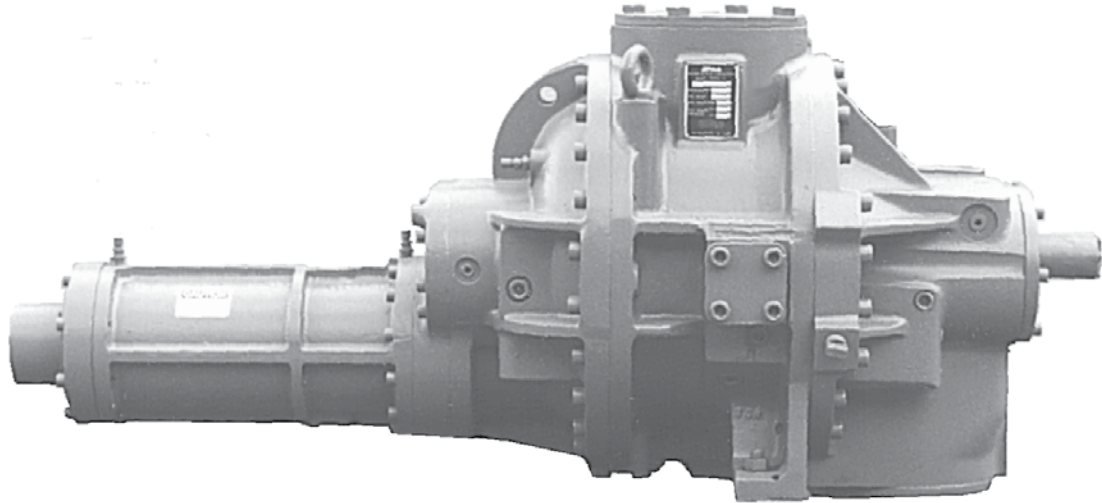

SPECIFICATIONS

The Frick® TDSH / PDSH screw compressors are designed to compress a variety of gases in many different applications including refrigeration, air conditioning, water chilling, wellhead compression, gas gathering, and vapor recovery. Applications include booster duty (low temperature/pressure), high (single) stage, or swing duty compression.

The TDSH compressor is used in typical refrigeration and natural gas applications where pressure retaining housings of cast iron are allowed. The PDSH compressor is used in applications requiring pressure retaining housings such as gas processing or refrigeration in chemical or petrochemical applications. Specifics of the housing materials are discussed under Materials of Construction on page 2.

Stepless Capacity Control - A hydraulically or manually actuated slide valve moves axially along the rotor mesh line to provide unloading. See charts on following pages for percentages. Unloaded gas is bypassed back to suction before compression has begun, allowing the compressor to efficiently accommodate system requirements.

Variable Volume Ratio - A hydraulically actuated slide stop adjusts slide valve length to optimize internal discharge pressure. This matches compressor volume ratio to system pressure ratio and eliminates the power penalties associated with under- or overcompression.

Antifriction Bearings - Cylindrical roller bearings handle radial loads, and angular contact ball bearings, aided by balance pistons, absorb thrust loads. No preloading is required. At design conditions, with proper lubrication and maintenance, bearing life is in excess of 100,000 hours. Roller bearings also maintain superior rotor positioning to minimize internal leakage and provide excellent performance. System differential pressure is normally sufficient as the driving force to supply oil to the bearings, thereby eliminating the need for an oil pump. Antifriction bearings have lower frictional horsepower requirements for lower power consumption. Compressor housings are machined to provide static oil reservoirs for the bearings.

Oil Injection - Injected oil serves to lubricate the bearings, balance piston, and seal, fill any leakage paths between and around the rotors to prevent gas bypassing, and maintain superior efficiencies. Oil injection minimizes noise and vibration. It keeps the compressor cool to prevent overheating by absorbing much of the heat from compression.

Made in the USA - The entire compressor is designed and built by Johnson Controls in Waynesboro, PA. Expert engineering, automated machining centers, clean temperature controlled assembly, and stringent quality control requirements, all contribute to ensuring easy installation, reliable operation, and convenient servicing.

MATERIALS OF CONSTRUCTION

Castings - ASTM A48 class 40 gray cast iron or equivalent is standard for pressure-retaining parts. Suction and discharge flanges comply with ANSI B16.1. A 150 class suction is standard on 163–283 sizes. A 300 class suction flange is standard on the 355 and 408. It is optional on all other models. A 300 class discharge flange is standard on all models.

Alternate casing material is ductile iron grade 60–40–18 per ASTM A395 and ASME SA 395 including a Charpy V-notch test at -4°F(-20°C) and a material certificate type 3.1 per EN 10204. Material is similar to European standard EN 1563, material designation EN-GJS-400-18.

ASTM A395 grade 60-40-18 is, however, standard on the 408.

ASTM A352 grade LCB, LC2, LC3 cast steel is available for all models in this publication.

Rotors - AISI 1141 low carbon steel. The 163 through 233 rotors are machined from hot-rolled bar stock. The 283, 355, and 408 rotors are forgings.

Bearings - Rolling elements and rings are AISI 52100 medium carbon alloy steel. Cages are brass, polyamide, or steel. Tolerance quality complies with ABEC 1 through 3.

Slide Valve Spindle - AISI 1141 or 1144 low carbon steel.
Slide Valve Indicator Rod - Type 416 stainless steel.
Slide Stop Indicator Rod - Type 304 stainless steel.

Pistons, Spacers, Etc. - Gray cast iron, A516 steel plate, regular carbon steel plate, or various types of hot rolled, cold rolled or cold drawn steel bar.

Retaining (Snap) Rings & Spring Washers - High carbon spring steel.

Bolts - Grade 8.8, heat treated, medium carbon steel, socket head cap screws.

Static Seals - HNBR O-rings. Viton also available.

Dynamic Seals - Carbon filled teflon.

Shaft Seal - Spring-loaded stationary carbon end face rides in a stainless steel carrier against a rotating nonmagnetic cast iron alloy (Ni-resist) floating seat. The assembly is fully balanced and capable of sealing up to 350 PSIG but is vented to low pressure to extend seal life. Secondary seals are HNBR or viton O-rings. Alternate seal designs and materials are available for some applications.

TYPICAL PERFORMANCE

Model	R-507 (HCFC)				Ammonia (R-717, NH ₃)				Natural Gas (SG=.65, k=1.26)			
	Capacity		Power		Capacity		Power		Capacity		Power	
	TR	kW	BHP	kW	TR	kW	BHP	kW	MMSCFD	MSCMH	BHP	kW
163S	135	476	160	119	126	443	146	109	0.359	0.423	31	23
163L	170	599	201	150	159	559	184	137	0.452	0.533	38	29
193S	228	800	264	197	213	749	235	175	0.644	0.759	47	35
193L	303	1067	352	263	284	999	314	234	0.859	1.013	62	47
233S	403	1418	459	342	384	1351	410	306	1.000	1.178	82	61
233L	508	1786	578	431	483	1699	517	386	1.385	1.632	104	78
233XL	627	2206	714	533	598	2103	638	476	1.711	2.016	128	96
283S	722	2541	823	613	688	2420	736	549	1.990	2.344	149	111
283L	910	3199	1036	772	866	3046	926	691	2.506	2.952	187	140
283SX	1095	3849	1246	929	1044	3673	1117	833	3.015	3.552	225	168
355S	1120	3937	1326	989	1066	3748	1169	872	3.191	3.759	233	174
355L	1527	5369	1808	1348	1453	5111	1594	1189	4.352	5.127	318	237
355XL	1943	6834	2485	1853	1850	6505	2032	1515	5.539	6.525	405	302
355U	N/A	N/A	N/A	N/A	N/A	N/A	N/A	N/A	6.979	8.230	510	381
408S	1811	6370	2273	1695	1792	6302	2006	1495	5.601	6.605	401	299
408L	2508	8821	3147	2346	2482	8729	2777	2070	7.756	9.146	555	413
408XL	2968	10438	4022	2999	2937	10,329	3286	2450	9.178	10.823	701	522

Notes:

1. SG=Specific Gravity, k=Ratio of Specific Heats (Cp/Cv), TR=Tons Refrigeration, kW=Kilowatts, BHP=Brake Horsepower, MMSCFD=Million Standard Cubic Feet per Day, MSCMH=Thousand Standard Cubic Meters per Hour.
2. R-507 ratings based on 20°F (-6.7°C) suction and 95°F (35°C) condensing with 10°F (5.5°C) liquid subcooling and 10°F (5.5°C) suction superheat at 3550 RPM.
3. R-717 ratings based on 20°F (-6.7°C) suction and 95°F (35°C) condensing with 10°F (5.5°C) liquid subcooling and 10°F (5.5°C) suction superheat at 3550 RPM.
4. Natural gas ratings based on 25 PSIA (172 kPaA), 80°F (27°C) suction and 75 PSIA (517 kPaA) discharge at 1750 RPM.

DESIGN LIMITATIONS AND MECHANICAL CHARACTERISTICS

	COMPRESSOR MODEL									
	163S	163L	193S	193L	233S	233L	233XL	283S	283L	283SX
Approx Compr. Wt. lb (kg)	1220 (555)	1280 (580)	1720 (780)	1895 (860)	2670 (1210)	2950 (1340)	3300 (1500)	4100 (1860)	4400 (2000)	4700 (2136)
Rotor Dia. mm	163		193		233			283		
Drive Arrangement	Directly driven by the male rotor in the clockwise direction as viewed from the driver									
Minimum Driver Speed ⁽¹⁾⁽²⁾ RPM	600 ⁽¹⁾⁽²⁾									
Maximum Driver Speed RPM	4500							3600 (For higher RPM, contact factory)		
Max. Input Power to Rotor Shaft BHP (KW) ⁽¹⁾	250 (186) ⁽¹⁾		450 (336) ⁽¹⁾		750 (559) ⁽¹⁾			1400 (1044) ⁽¹⁾		
Min. Breakaway Torque ft-lb (Nm)	7 (9.5)		10 (13.5)		14 (19.0)			20 (27.1)		
Mass Moment of Inertia ⁽³⁾ ft ² -lb _m (m ² -kg)	2.2 (.093) ⁽³⁾	2.7 (.11) ⁽³⁾	5.1 (.21) ⁽³⁾	6.5 (.27) ⁽³⁾	13 (.55) ⁽³⁾	16 (.67) ⁽³⁾	18 (.77) ⁽³⁾	33 (1.4) ⁽³⁾	41 (1.7) ⁽³⁾	48 (2.0) ⁽³⁾
Suction Flange in. (mm)	4 (102)		5 (127)	6 (152)		8 (203)	10 (254)			
Discharge Flange in. (mm)	3 (76)		4 (102)		6 (152)			8 (203)		
Theoretical Displacement ft ³ /rev. (m ³ /rev.)	.10069 (.002851)	.12679 (.003590)	.16653 (.004716)	.22204 (.006240)	.29301 (.008297)	.36897 (.01045)	.45580 (.01291)	.52501 (.01487)	.66113 (.01872)	.79546 (.02253)
Displ. at 3550 rpm Driver Speed ft ³ /min (m ³ /hr)	357 (607)	450 (765)	591 (1004)	788 (1339)	1040 (1767)	1310 (2225)	1618 (2749)	1864 (3167)	2347 (3988)	2824 (4798)
Displ. at 2950 rpm Driver Speed ft ³ /min (m ³ /hr)	297 (505)	374 (636)	491 (835)	655 (1113)	864 (1468)	1088 (1849)	1345 (2284)	1549 (2631)	1950 (3314)	2347 (3987)
Displ. at 1750 rpm Driver Speed ft ³ /min (m ³ /hr)	176 (299)	222 (377)	291 (495)	389 (660)	513 (871)	646 (1097)	798 (1355)	919 (1561)	1157 (1966)	1392 (2365)
Displ. at 1450 rpm Driver Speed ft ³ /min (m ³ /hr)	146 (248)	184 (312)	242 (410)	322 (547)	425 (722)	535 (909)	661 (1123)	761 (1293)	959 (1629)	1153 (1960)
Capacity Control	Infinitely adjustable from 100% to aprox. 10% (23% - 233XL, 15% - 283S/L, 26% - 283SX) by piston- or handwheel-actuated slide valve									
Volume Ratio	Infinitely adjustable from 5.0 to 2.2 (283SX - 4.15 to 2.2)									
Max. Inlet Press. psia (bara) ⁽¹⁾	150.0 (10.3) ⁽¹⁾									
Max. Outlet Press. psia (bara) ⁽¹⁾⁽⁵⁾	400.0 (27.6) ⁽¹⁾⁽⁵⁾									
Max. Outlet Press. psia (bara) ⁽¹⁾⁽⁶⁾	600.0 (41.4) ⁽¹⁾⁽⁶⁾									
Minimum Inlet Temp. ⁽⁴⁾ °F (°C) ⁽¹⁾	-76.0 (-60.0) ⁽¹⁾									
Maximum Inlet Temp. °F (°C) ⁽¹⁾	200.0 (93.3) ⁽¹⁾									
Maximum Outlet Temp. °F (°C) ⁽¹⁾	250.0 (121.1) ⁽¹⁾									
Maximum Temp. Dif. (Suct. to Disch.) °F (°C) ⁽¹⁾	250.0 (138.9) ⁽¹⁾									
Max. Bearing Oil Supply Temp. °F (°C) ⁽¹⁾	230.0 (110.0) ⁽¹⁾									

1. Contingent upon compression ratio, bearing L10 limitations, oil viscosity, and other operating conditions.
2. Compressor suction flow may be zero at full unload slide valve position below 1800 RPM (1200 for 355).
3. Does not include coupling. Resolved to drive shaft.
4. At compressor suction flange. Minimum evaporator temperature can be lower.
5. Standard ASTM A48 class 40 gray cast iron. Some compressors capable of higher pressures in cast iron. Consult Factory.
6. Ductile iron ASTM A395 grade 60-40-18, or cast steel A352 grade LCB, LC2, LC3.

DESIGN LIMITATIONS AND MECHANICAL CHARACTERISTICS

	COMPRESSOR MODELS						
	355S	355L	355XL	355U	408S	408L	408XL
Approx. Compr. Wt. lb. (kg)	7200 (3400)	8240 (3740)	9200 (4172)	10,200 (4625)	14,000 (6350)	15,500 (7030)	16,400 (7438)
Rotor Dia. mm	355			408			
Drive Arrangement	Directly driven by the male rotor in the clockwise direction as viewed from the driver						
Minimum Driver Speed ⁽¹⁾⁽²⁾ RPM	600 ⁽¹⁾⁽²⁾						
Maximum Driver Speed RPM	3600						
Max. Input Power to Rotor Shaft BHP (KW) ⁽¹⁾	3500 (2609) ⁽¹⁾				6000 (4474) ⁽¹⁾		
Min. Breakaway Torque ft-lb (Nm)	25 (33.9)				31 (42.0)		
Mass Moment of Inertia ⁽³⁾ ft ² -lb _m (m ² -kg)	97 (4.1) ⁽³⁾	110 (4.8) ⁽³⁾	135 (5.7) ⁽³⁾	154 (6.5) ⁽³⁾	154 (6.5) ⁽³⁾	214 (9.0) ⁽³⁾	251 (10.6) ⁽³⁾
Suction Flange in. (mm)	14 (356)				12 (305)	16 (406)	
Discharge Flange in. (mm)	10 (254)				12 (305)		
Theoretical Displacement ft ³ /rev. (m ³ /rev.)	.82248 (.02329)	1.12160 (.03177)	1.42750 (.04042)	1.80316 (.05106)	1.41180 (.03998)	1.95481 (.05535)	2.31319 (.06550)
Displ. at 3550 rpm Driver Speed ft ³ /min (m ³ /hr)	2920 (4961)	3982 (6765)	5068 (8610)	6401 (10,875)	5012 (8515)	6940 (11,790)	8212 (13,952)
Displ. at 2950 rpm Driver Speed ft ³ /min (m ³ /hr)	2426 (4122)	3309 (5621)	4211 (7155)	5319 (9037)	4165 (7076)	5767 (9798)	6824 (11,594)
Displ. at 1750 rpm Driver Speed ft ³ /min (m ³ /hr)	1439 (2445)	1963 (3335)	2498 (4244)	3156 (5361)	2471 (4198)	3421 (5812)	4048 (6878)
Displ. at 1450 rpm Driver Speed ft ³ /min (m ³ /hr)	1192 (2026)	1626 (2763)	2072 (3517)	2615 (4442)	2047 (3478)	2834 (4816)	3354 (5699)
Capacity Control	Infinitely adjustable from 100% to aprox. 15% (21% - 355XL, 25% - 355U) by piston- or handwheel-actuated slide valve				Infinitely adjustable from 100% to aprox. 12% (15% - 408XL) by piston		
Volume Ratio	Infinitely adjustable from 5.0 to 2.2						
Max. Inlet Press. psia (bara) ⁽¹⁾	150.0 (10.3) ⁽¹⁾						
Max. Outlet Press. psia (bara) ⁽¹⁾	400.0 (27.6) ⁽¹⁾⁽⁵⁾						
Max. Outlet Press. psia (bara) ⁽¹⁾	600.0 (41.4) ⁽¹⁾⁽⁶⁾						
Minimum Inlet Temp. ⁽⁴⁾ °F (°C) ⁽¹⁾	-76.0 (-60.0) ⁽¹⁾						
Maximum Inlet Temp. °F (°C) ⁽¹⁾	200.0 (93.3) ⁽¹⁾						
Maximum Outlet Temp. °F (°C) ⁽¹⁾	250.0 (121.1) ⁽¹⁾						
Maximum Temp. Dif. (Suct. to Disch.) °F (°C) ⁽¹⁾	250.0 (138.6) ⁽¹⁾						
Max. Bearing Oil Supply Temp. °F (°C) ⁽¹⁾	230.0 (110.0) ⁽¹⁾						

1. Contingent upon compression ratio, bearing L10 limitations, oil viscosity, and other operating conditions.
2. Compressor suction flow may be zero at full unload slide valve position below 1800 RPM (1200 for 355).
3. Does not include coupling. Resolved to drive shaft.
4. At compressor suction flange. Minimum evaporator temperature can be lower.
5. Standard ASTM A48 class 40 gray cast iron. Some compressors capable of higher pressures in cast iron. Consult Factory.
6. Ductile iron ASTM A395 grade 60-40-18 (standard on 408), or cast steel A352 grade LCB, LC2, LC3.

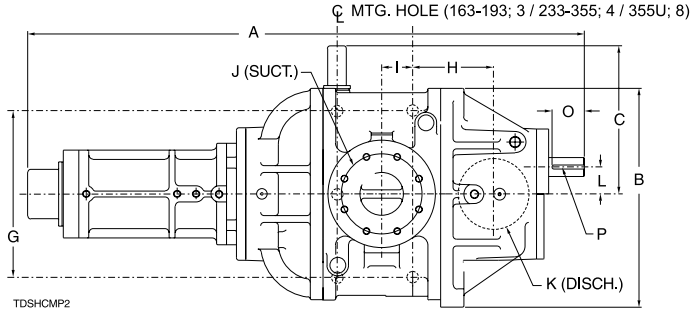

TOP VIEW

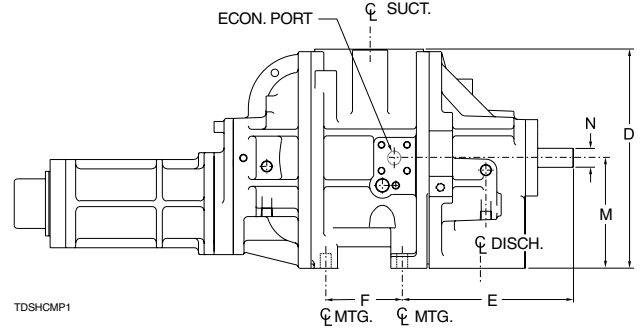

SIDE VIEW

DIMENSIONAL OUTLINE

APPROXIMATE DIMENSIONS		COMPRESSOR MODEL									
		163S	163L	193S	193L	233S	233L	233XL	283S	283L	283SX
A	in. (mm)	49.60 (1260)	51.85 (1317)	58.23 (1479)	61.65 (1566)	66.52 (1690)	69.72 (1771)	74.36 (1889)	71.95 (1828)	75.85 (1927)	80.31 (2039)
B	in. (mm)	20.39 (518)		22.76 (578)		25.00 (635)			29.50 (749)		
C	in. (mm)	13.81 (351)		14.75 (375)		16.13 (410)		16.25 (413)	18.43 (468)		
D	in. (mm)	21.46 (545)	20.32 (516)	24.02 (610)	22.68 (576)	26.72 (679)	25.63 (651)	26.72 (679)	28.75 (730)		
E	in. (mm)	15.87 (403)		18.82 (478)		20.97 (533)			18.30 (465)		
F	in. (mm)	4.84 (123)	7.09 (180)	6.10 (155)	9.52 (242)	6.52 (166)	9.72 (247)	13.4 (340)	22.84 (580)	26.74 (679)	31.19 (792)
G	in. (mm)	14.96 (380)		16.54 (420)		20.12 (511)			22.24 (565)		
H	in. (mm)	7.44 (189)		8.19 (208)		9.58 (243)			5.12 (130)		
I	in. (mm)	1.89 (48)	2.99 (76)	2.44 (62)	4.17 (106)	3.26 (83)	4.86 (123)	6.70 (170)	24.21 (615)	28.11 (714)	32.56 (827)
J	in. (mm)	4.00 (102)		5.00 (127)	6.00 (152)	8.00 (203)		10.00 (254)			
K	in. (mm)	3.00 (76)		4.00 (102)		6.00 (152)			8.00 (203)		
L	in. (mm)	2.52 (64)		2.98 (76)		3.60 (91)			4.37 (111)		
M	in. (mm)	10.24 (260)		11.42 (290)		12.88 (327)			15.25 (387)		
N	in. (mm)	1.75 (44)		2.25 (57)		2.50 (64)			3.25 (83)		
O	in. (mm)	3.00 (76)		3.75 (95)		3.81 (97)			5.00 (127)		
P	in. (mm)	0.38 (10)		0.50 (13)		0.63 (16)			0.88 (22)		

Notes:

1. A TDSH163 is shown for illustrative purposes only. Configurations of other compressor sizes vary slightly.
2. The economizer port in model 233-355 compressors is located on the outlet housing.
3. The suction flange on model 283 and 355 compressors is located on the inlet housing.

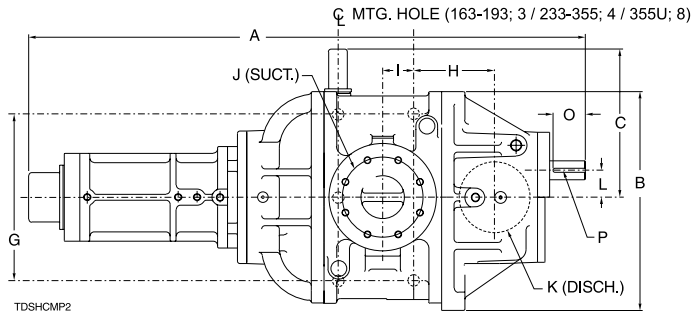

TOP VIEW

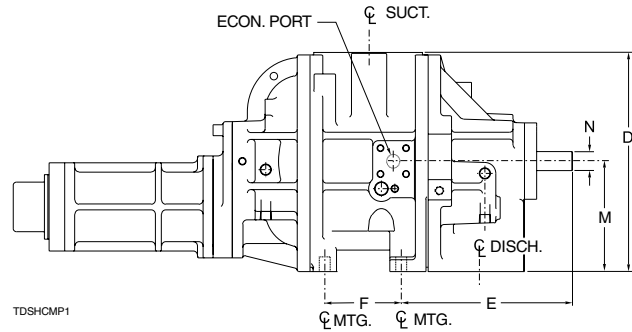

SIDE VIEW

DIMENSIONAL OUTLINE

APPROXIMATE DIMENSIONS		COMPRESSOR MODEL						
		355S	355L	355XL	355U	408S	408L	408XL
A	in. (mm)	84.81 (2154)	90.39 (2296)	95.99 (2438)	102.96 (2615)	98.32 (2497)	106.34 (2701)	111.64 (2836)
B	in. (mm)	38.47 (977)			36.94 (938)	45.42 (1154)		
C	in. (mm)	21.67 (550)				25.98 (660)		
D	in. (mm)	35.88 (911)				47.00 (1194)		
E	in. (mm)	10.36 (263)			10.32 (262)	28.06 (713)		
F	in. (mm)	36.55 (928)	42.13 (1070)	47.73 (1212)	54.75 (1391)	35.10 (892)	43.13 (1096)	48.42 (1230)
G	in. (mm)	27.00 (686)				29.00 (737)		
H	in. (mm)	8.13 (207)				11.56 (294)		
I	in. (mm)	40.40 (1026)	45.98 (1168)	51.58 (1310)	58.60 (1488)	17.55 (446)	21.56 (548)	24.21 (615)
J	in. (mm)	14.00 (356)				12.00 (305)	16.00 (406)	
K	in. (mm)	10.00 (254)				12.00 (305)		
L	in. (mm)	5.47 (139)				6.50 (165)		
M	in. (mm)	19.12 (486)				26.00 (660)		
N	in. (mm)	3.75 (95)				4.937 (125)		
O	in. (mm)	5.00 (127)				5.50 (140)		
P	in. (mm)	0.88 (22)				1.25 (32)		

Notes:

1. A TDSH163 is shown for illustrative purposes only. Configurations of other compressor sizes vary slightly.
2. The economizer port in model 233-355 compressors is located on the outlet housing.
3. The suction flange on model 283 and 355 compressors is located on the inlet housing.
4. 355 and 408 size compressors have a side discharge arrangement. The flange is located on the right side of the outlet housing as viewed from the driver.
5. The drive-end mounting holes in model 355 compressors are located inboard of the discharge flange with respect to the drive shaft.

MODEL NUMBER EXPLANATION

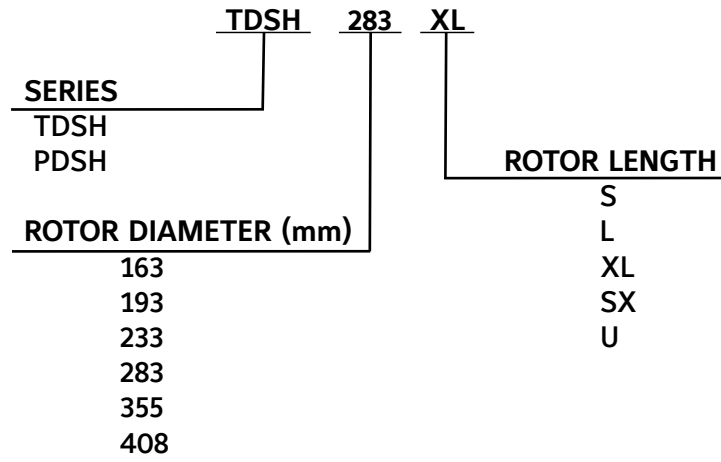

NOTES