









PowerPhase technical training manual

METTLER TOLEDO

Table of Contents

Section 1: Detector System Overview	1 - 2	
Section 2: Detector Theory	3 - 13	
Section 3: Software Levels	14 - 24	
Section 4: User Settings and Adjustments	25 - 72	
Section 5: Troubleshooting	73 - 85	
Section 6: Notes	86 - 88	

DETECTOR SYSTEMS OVERVIEW

1.1 TERMINOLOGY

A. Detector Search Head

- I. Detector Aperture II. Aperture Liner III. Former IV. Three Coil System

B. Control Module

- I. Keypad II. Bar Graph Display III. Detection LED IV. LCD Display

C. Power Supply

- I. Top Connection Circuit Board II. Digital Switchmode Power Supply

D. Interconnection Board

- I. EEPROM Memory II. Ribbon Connection Cable

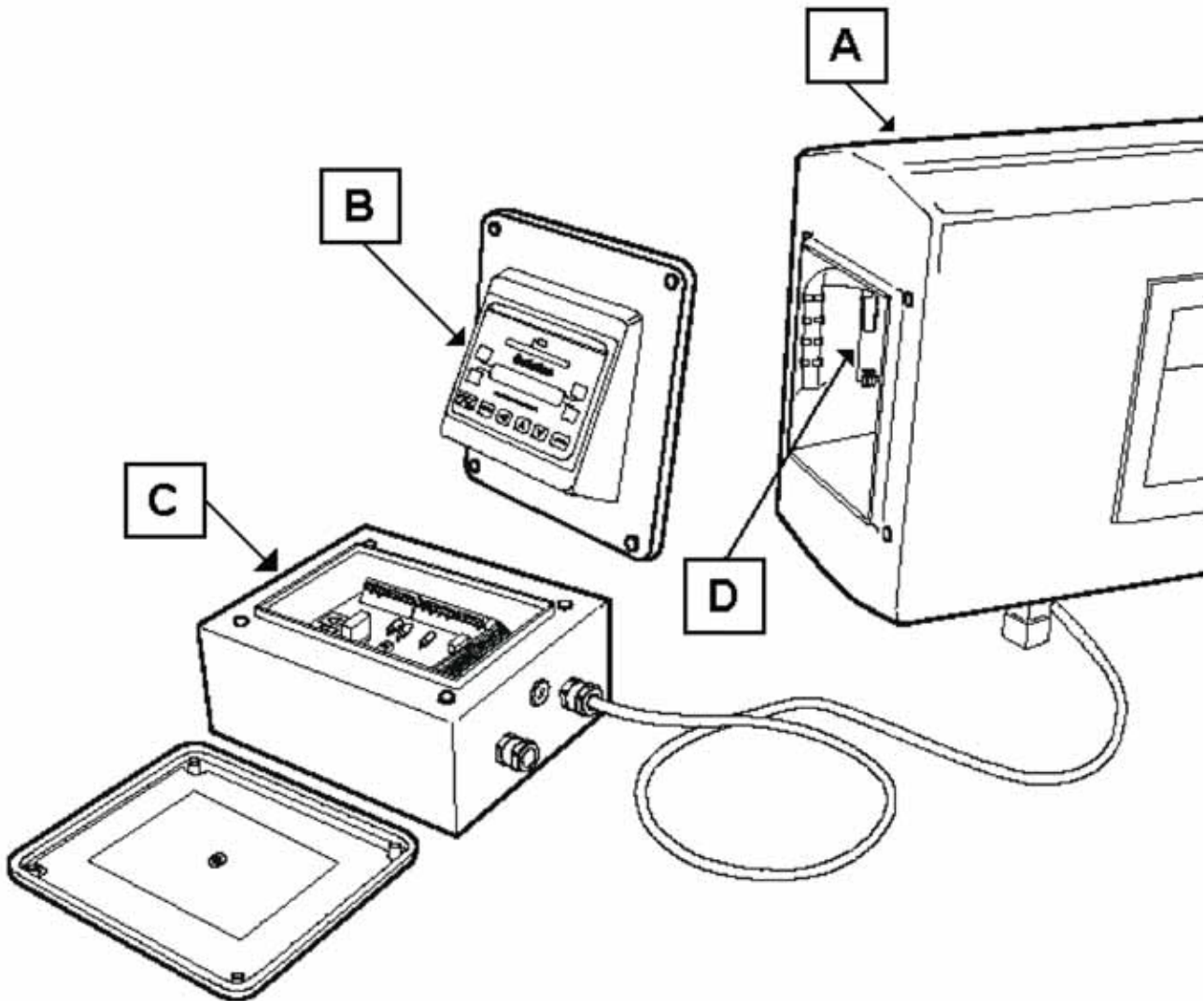

1.2 SYSTEM CONFIGURATIONS

A. Standard Systems

- I. The Control Module is mounted directly to the detector search head.
- II. The power supply is housed in a separate enclosure (i.e. the motor control enclosure).

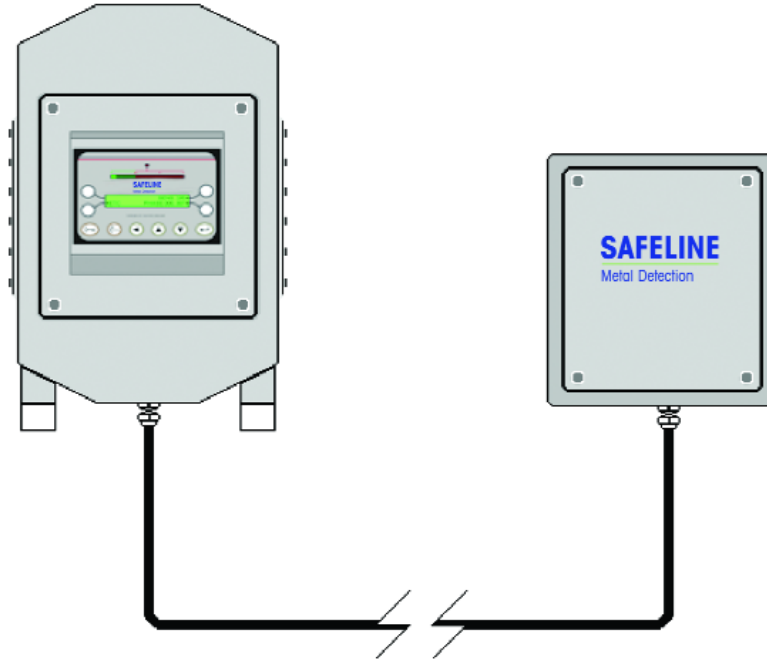

B. Remote Systems

- I. The Control Module and power supply are combined together in a separate remote electronics enclosure.
- II. The detector search head is connected to the system electronics enclosure by way of two remote connecting cables.

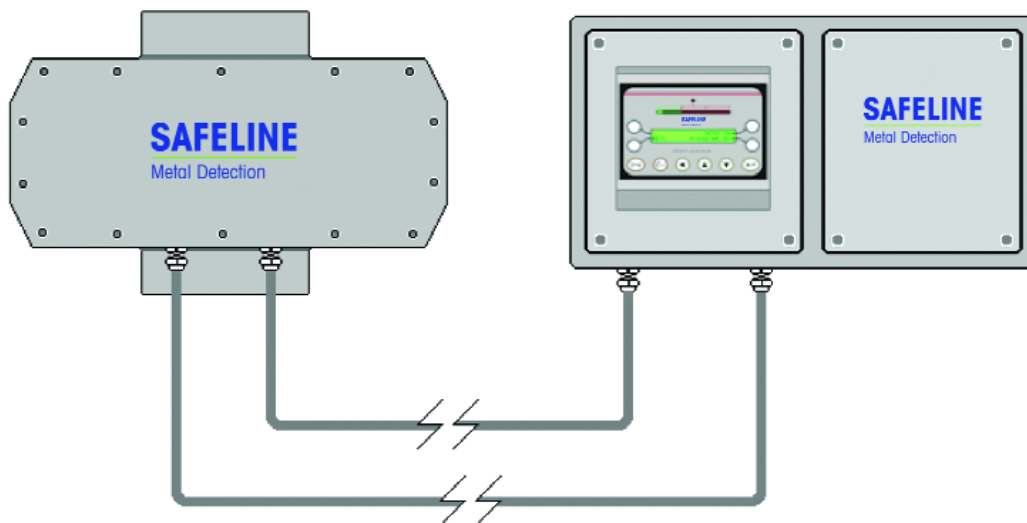

DETECTOR THEORY

2.1 SEARCH HEAD CONSTRUCTION

A. Case Construction and Finish

1. Painted White

- I. Used for mild environments
- II. Wipe down cleaning ONLY
- III. Powerphase Systems use "Super-Drive" Modules

2. Stainless Steel

- I. Used for harsh environments
- II. Frequent / Heavy Washdown Applications (NEMA 4X)
- III. Powerphase Systems use non "Super-Drive" Modules

3. Polished Chrome

- I. Used for mild environments
- II. Wipe down cleaning ONLY
- III. Frequently used with Pharmaceutical Systems

B. Solid Potting

- I. Minimizes the effects of Vibration
- II. Secures the Former firmly in place

C. Former Rectangular or Square

- I. Made of the phenolic material "Trespar"
- II. Selected for its rigid characteristics

Round

- I. Made of Fiberglass
- II. Can be rigidly formed for circular apertures

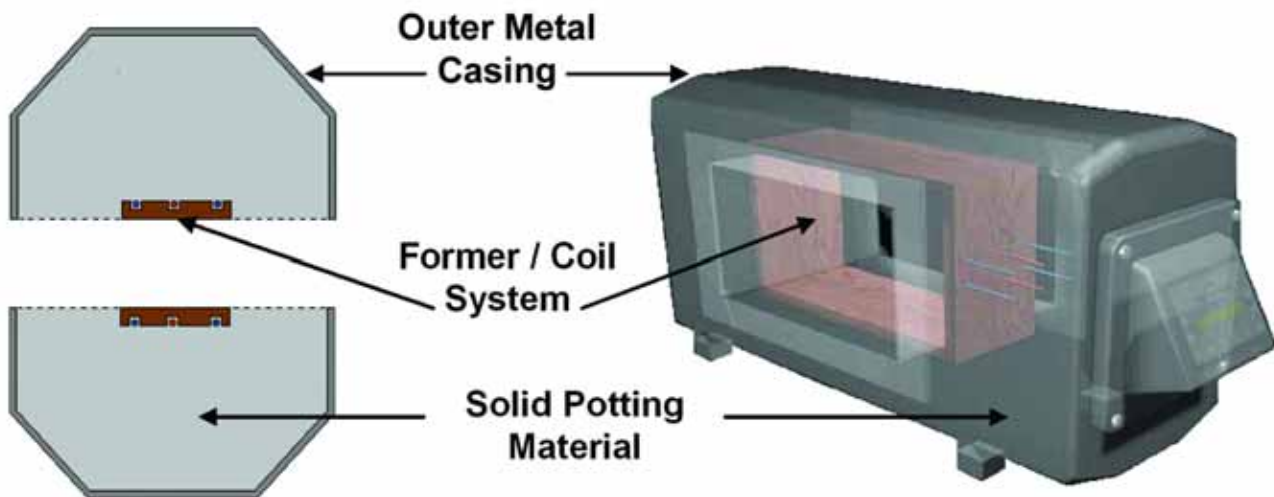

Detector Search Head (cut-away view)

2.2 THREE COIL SYSTEM

A. Description

Beneath the liner in the aperture, lies the former assembly. Embedded in the former assembly are (3) solid copper wires that are wrapped around the former. The former/3 coil system surrounds the product as it passes through the detector aperture. The center coil is referred to as the "excitation", or transmitter coil. On either side of the transmitter coil, are the (2) receiving coils. The two receiving coils are wound around the former assembly in opposite directions to one another.

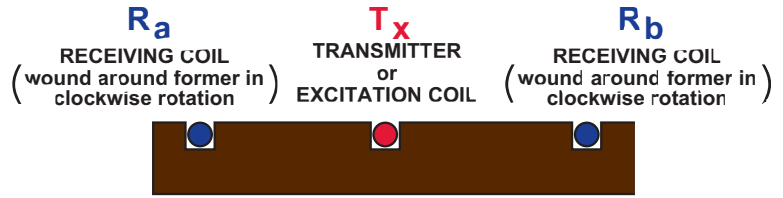

B. Excitation Coil (TX)

A high frequency, low power amplifier located in the Control Module, applies a signal to the excitation coil. This causes the coil to transmit an electromagnetic field outward in all directions.

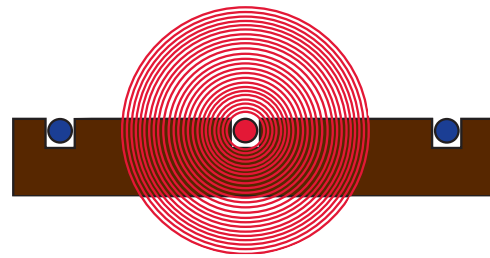

C. Receiving Coils (Ra & Rb)

When the high frequency electromagnetic field radiates past the two receiving coils, a signal is induced into the coils.

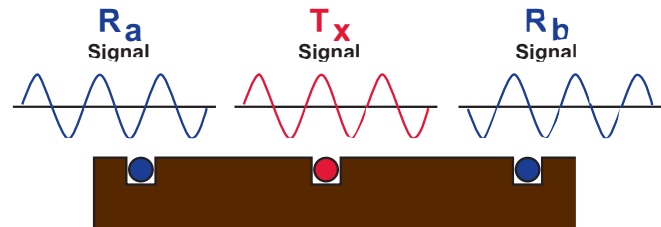

Due to the reverse winding relationship of the two receiving coils, one of the coils receives the transmitter signal "in phase" with the transmitter signal, while the opposite receiving coil receives the signal as a mirror image of the transmitter signal or "180 degrees out of phase".

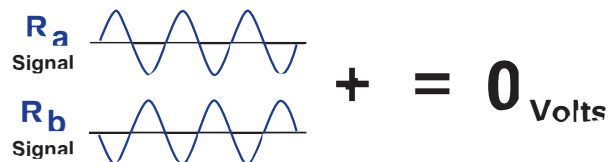

The two signals from the receiving coil are then processed and added together. Because the two signals are 180 degrees phase shifted, when these two signals combine, they will cancel each other out and produce a 0-volt condition.

2.3 METAL FREE ZONE

A. Description

The aperture opening of the detector allows some of the electromagnetic field generated by the transmitter to extend beyond the case. Any external metal must be kept at a distance from this point. This area or "zone" is referred to as the metal free zone of the detector. An approximation formula can be used to calculate the required distance of the zone and is based on the height of the aperture dimension.

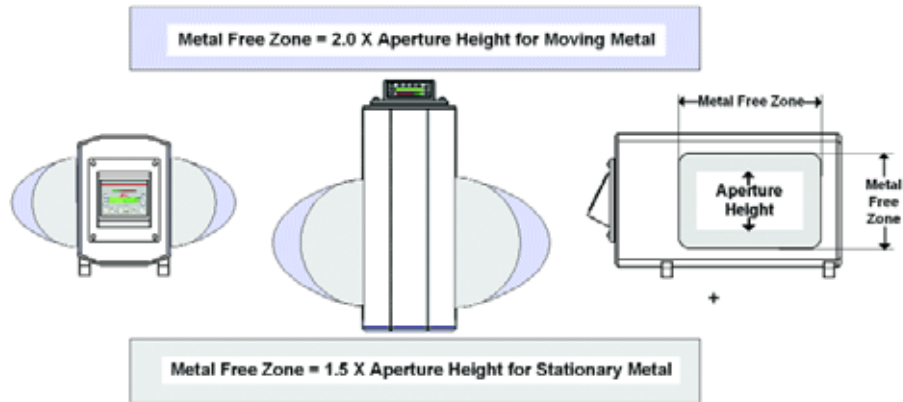

B. Zero Peripheral Metal Free Zone Detector (ZPMFZ)

This specially designed detector allows for a tighter field pattern that restricts the field very close to the aperture opening. This design permits metal to be positioned much closer to the peripheral of the aperture. Typical applications include vertical form fill bagging.

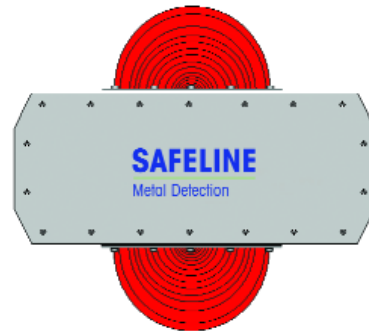

2.4 SENSITIVITY

A. Definition

The sensitivity of a metal detector is stated as the smallest diameter metal sphere that is consistently detectable in the center of the detector aperture. Many factors can have an influence on a detectors sensitivity. The following list contains some of the primary influencing factors:

1. Type of metal	6. Operating frequency
2. Shape of metal	7. Product effect
3. Orientation of metal	8. Environmental conditions
4. Position of the metal in the aperture	9. Electromagnetic ground loops
5. Aperture dimensions	10. Detector settings mis-adjustment

B. Signal Generation

A. Description

A metal sphere approaching the aperture begins to influence the first receiving coil by inducing a voltage. This conduction imbalances the normal "zero output condition" and a voltage signal begins to develop.

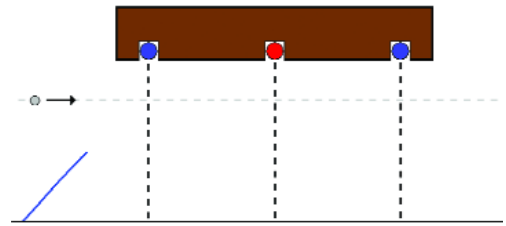

When the sphere reaches a position directly beneath the first receiving coil, the maximum conduction occurs, and a peak positive voltage is output.

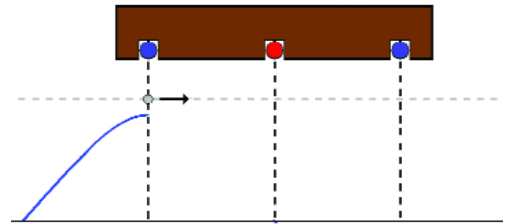

As the sphere moves away from the first receiving coil, a decrease in conduction begins to occur. The output voltage begins to drop off.

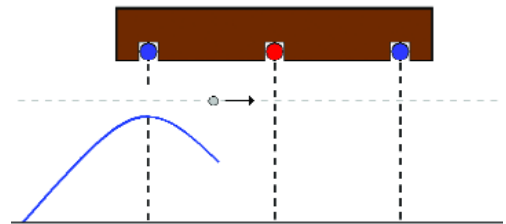

When the sphere reaches the center coil, a momentary state of balance is achieved since the sphere's influence is equal to both receiving coils. The output voltage drops momentarily to 0 Volts.

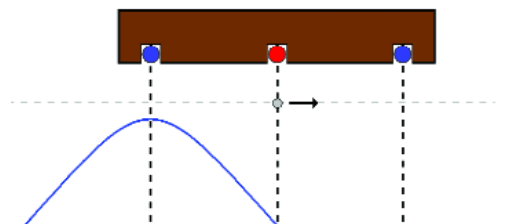

As the sphere approaches the second receiving coil, conduction begins to induce and output voltage. The polarity of this signal is opposite that of the first coil due to the reverse coil winding relationship.

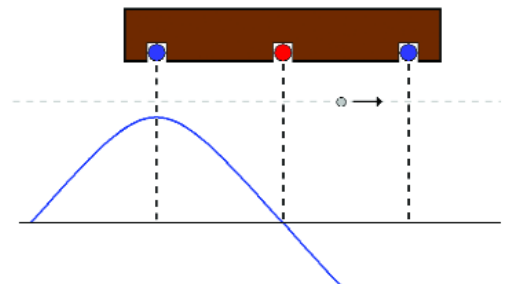

When the sphere is positioned directly beneath the second receiving coil, a maximum negative output voltage is reached.

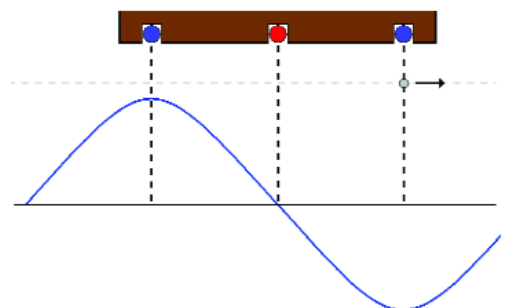

As the sphere exits the aperture, the voltage drops back to the original 0 Volt output condition.

C. Amplitude Detection

The signal generated as a result of the metal sphere passing through the metal detector aperture in then processed by the system electronics. The signal is referenced to a fixed positive and negative threshold. If the maximum peak signal is large enough to exceed either the positive or negative threshold points, then a detection will be registered. This method of signal detection is referred to as "amplitude detection".

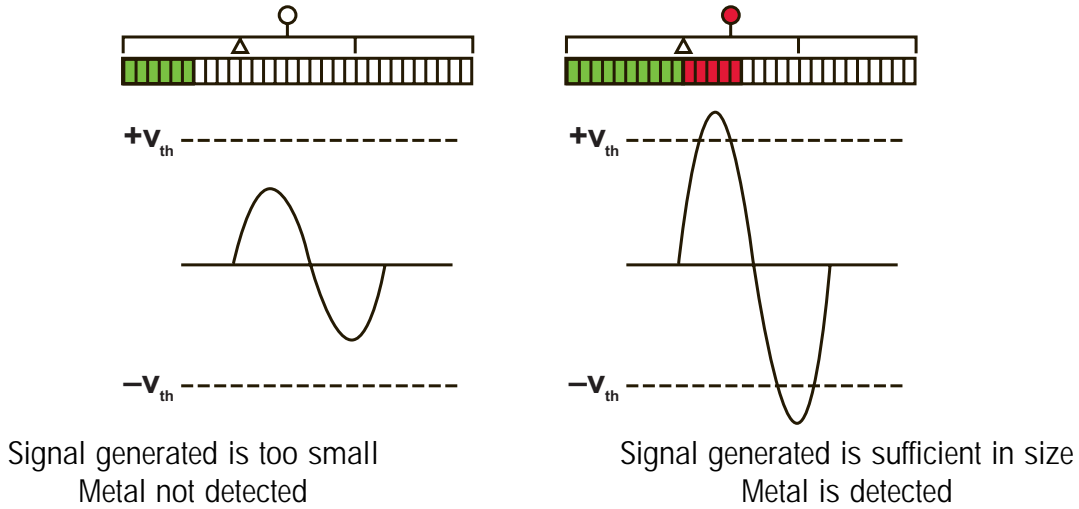

D. Operating Frequency

The operating frequency of a detector is the electromagnetic wave frequency that the transmitter operates at (typically this in the Kilohertz range). If two metal detectors have the same aperture dimensions, the same maximum sensitivity settings, and no product phase applied, the detector with the highest operating frequency will have the best metal finding capabilities. A metal detectors chosen operating frequency is determined by testing the product to be run on that unit. Often times, the product will be the determining factor as to which frequency will yield the best product set-up and overall metal finding capabilities.

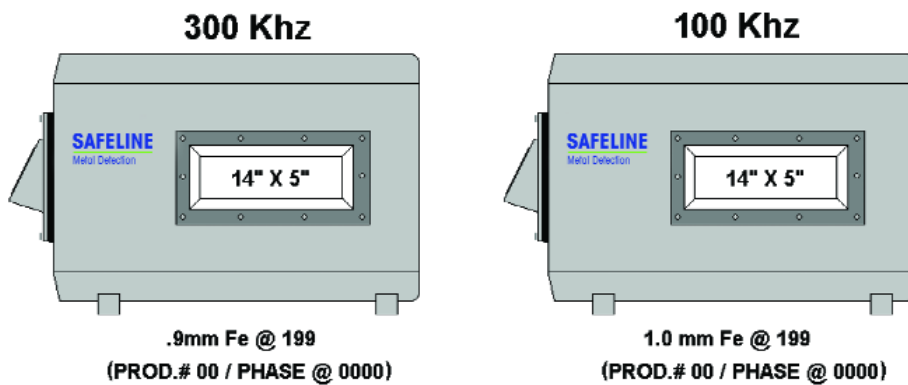

COMMON METAL DETECTOR OPERATING FREQUENCIES

STANDARD	PHARMACEUTICAL	POWERPHASE
25Khz	600Khz	25Khz / 100Khz
100Khz	800Khz	100Khz / 300Khz
300Khz		300Khz / 800Khz

E. Aperture Dimensions

The aperture opening size is another factor that effects sensitivity. Typically, the detectors aperture size is selected based on the maximum product size to be passed. If two detectors have similar operating frequency, the same maximum settings and no product phase, the detector with the smallest aperture will have the best metal sensitivities. This is primarily due to the coil system being positioned closer to the metal. As the aperture size increases, the signal generated diminishes.

300 KHz (16" x 8")

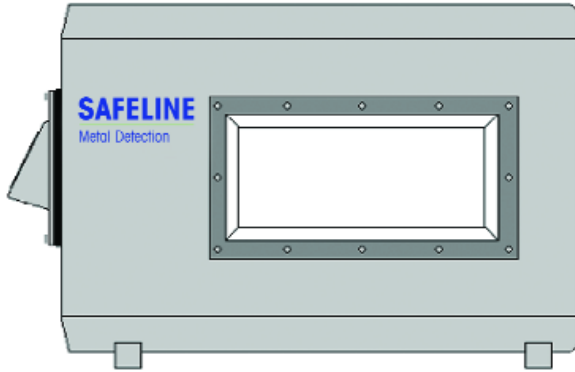

Sensitivity = 199 Product Phase = 0

Minimum detectable ferrous sphere in the center of the aperture is 1.5mm.

300KHz (10"x3")

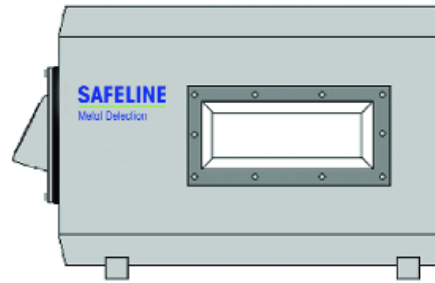

Sensitivity = 199 Product Phase = 0

Minimum detectable ferrous sphere in the center of the aperture is 0.7mm.

F. Aperture Position

The strength of the high frequency electromagnetic field is less in the direct center of the detector aperture. This is due to the former/coil assembly being positioned around the circumference of the aperture opening. Moving from the center aperture position in any direction toward the aperture liner, the sensitivity increases. The typical sensitivity gradient is less than two diameters. This is the difference in sensitivity measured at the center of the detector aperture and the sensitivity at any other point in the aperture not closer than 10mm to the liner surface.

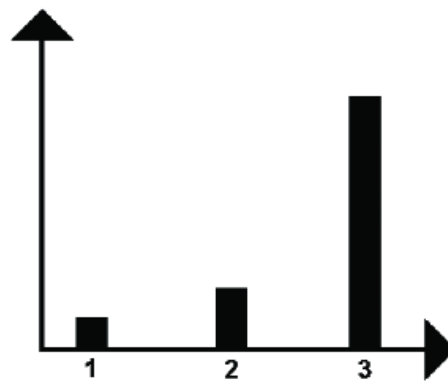
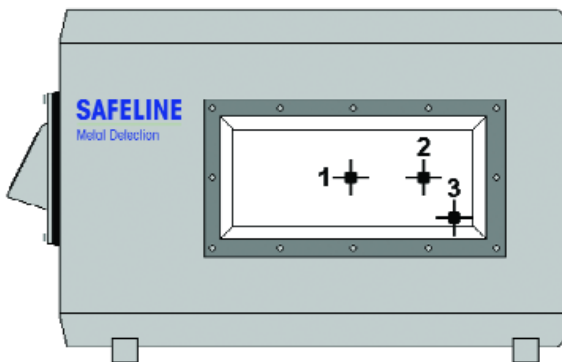

G. Metal Types

Different types of metals have an effect on a detectors sensitivity. The primary reasons for this are the physical structure of the metal, the electrical and magnetic characteristics, and the percentage of elements present, (this is most important in the consideration of the various grades of stainless steel). This hierarchy of the different types of metal is similar for all forms of coil based metal detectors.

Metal Type(s)	Category	Permeability	Conductivity	Ease of Detection
Iron	Ferrous	Excellent	Good	Very Easy
Copper Aluminum Brass Lead Zinc	Non-Ferrous	Good	Good To Excellent	Relatively Easy
Various Grades of Stainless Steel	Non-Ferrous	Usually Poor	Usually Poor	Relatively Difficult

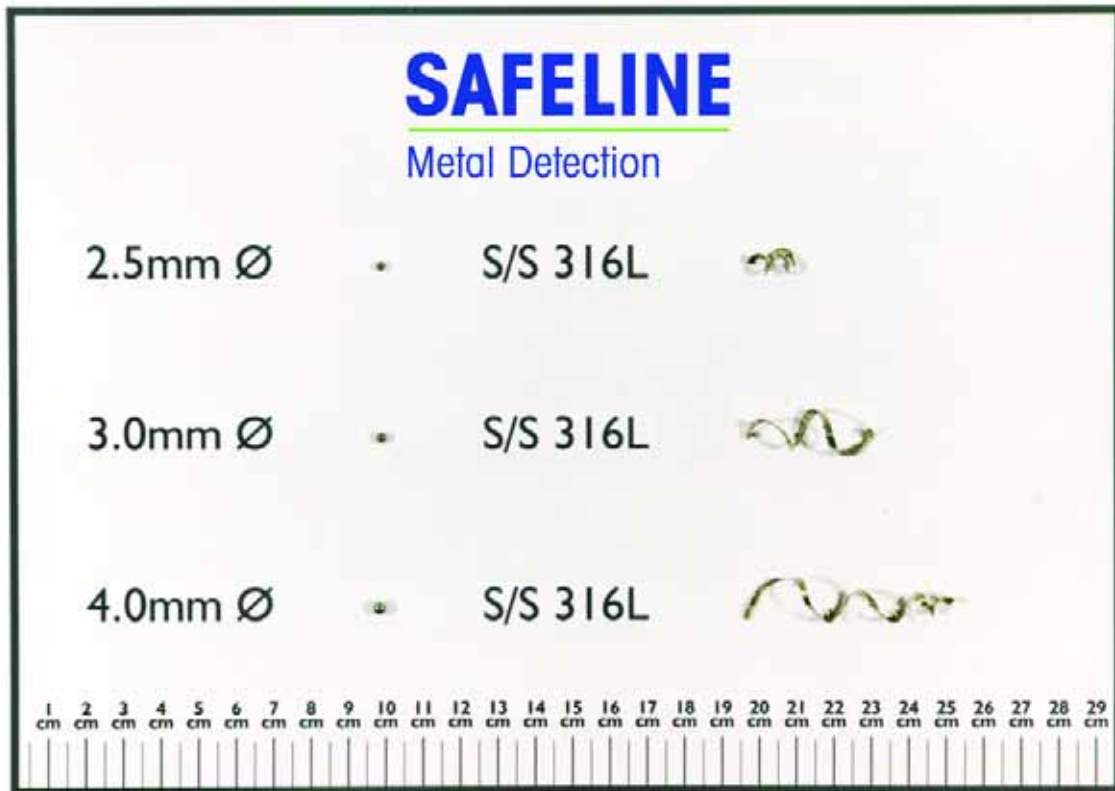

Spherical Metal Samples and Spiral Contamination Equivalents

H. Orientation Effect

When testing the metal detector, it is common to use calibrated test spheres. The reason for this is that a sphere has the same cross-sectional area regardless of how it is turned. Typically, most metal contamination is in some elongated, irregular form. Depending on the type of metal, and its orientation relative to entering the detectors aperture, the metal may be easy or difficult for the detector to detect.

This phenomenon is referred to as "orientation effect", and is inherent to all coil based metal detectors.

Orientation effect is only evident when the metal contamination's cross-sectional area is smaller than the detectors minimum spherical capabilities for that same type of metal.

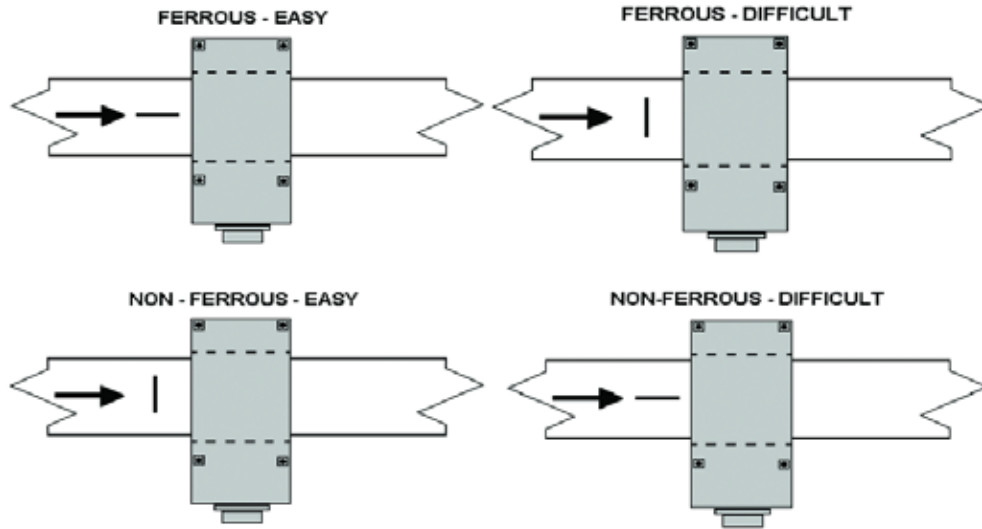

If the metal contamination's diameter is smaller than the detectors capabilities for that same metal type, it maybe detectable if the metals overall length is sufficient. If the metal contamination is less than 1/3 the detectors minimum capabilities for that same type of metal, it may not be detected regardless of how long it is.

SPHERICAL SENSITIVITY	STEEL PAPER CLIP Dia.= 0.95mm (0.037")	TINNED COPPER WIRE Dia.= 0.91mm (0.036")	COPPER WIRE Dia.= 1.37mm (0.054")	STAINLESS STEEL EN58E Dia.=1.60mm (0.063")
• 1.2mm	- 1.5mm Long (0.06")	- 3.5mm Long (0.14")		
• 1.5mm	- 3.0mm Long (0.12")	- 9.0mm Long (0.36")	- 3.0mm Long (0.12")	- 8.0mm Long (0.31")
• 2.0mm	- 6.0mm Long (0.24")	- 26.0mm Long (1.02")	- 8.0mm Long (0.31")	- 24.0mm Long (0.96")
• 2.5mm	- 11.0mm Long (0.44")	- 55.0mm Long (2.17")	- 18.0mm Long (0.72")	- 64.0mm Long (2.52")

Orientation effect as a function of spherical sensitivity

2.5 PHASE

A. Phase Relations

When objects pass through the aperture of the metal detector, they interact with the electromagnetic field generated by the high frequency transmitter coil. Depending on the composition of the substance(s), a phase shift can occur.

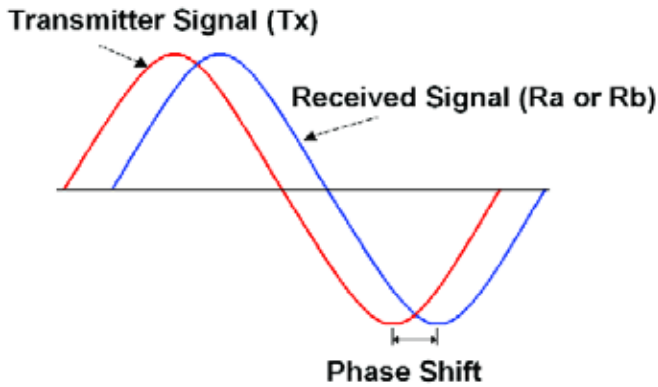
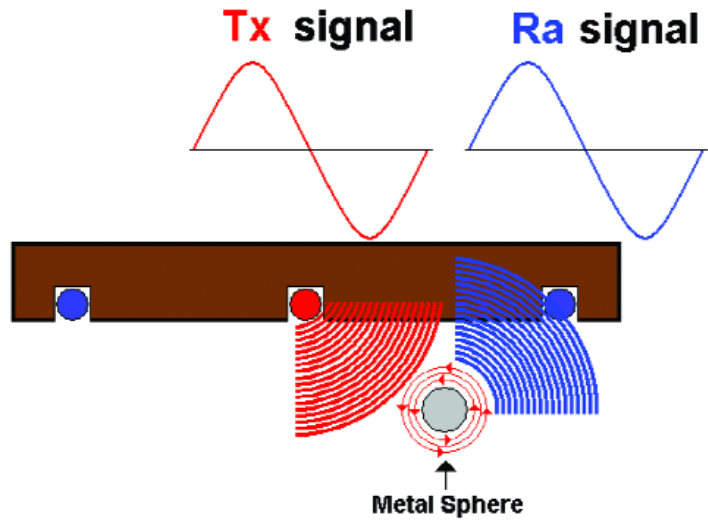

Comparing the signal of the receiving coils with the original signal generated by the transmitter coil, it is noted that the signals are not in phase.

B. Phase Vectors

To express the phase shift variations that occur, it is common to plot the angle as a function of an X-Y vector.

The example shows some of the common metal types and the phase shifts that occur, and how they would be plotted on the X-Y graph.

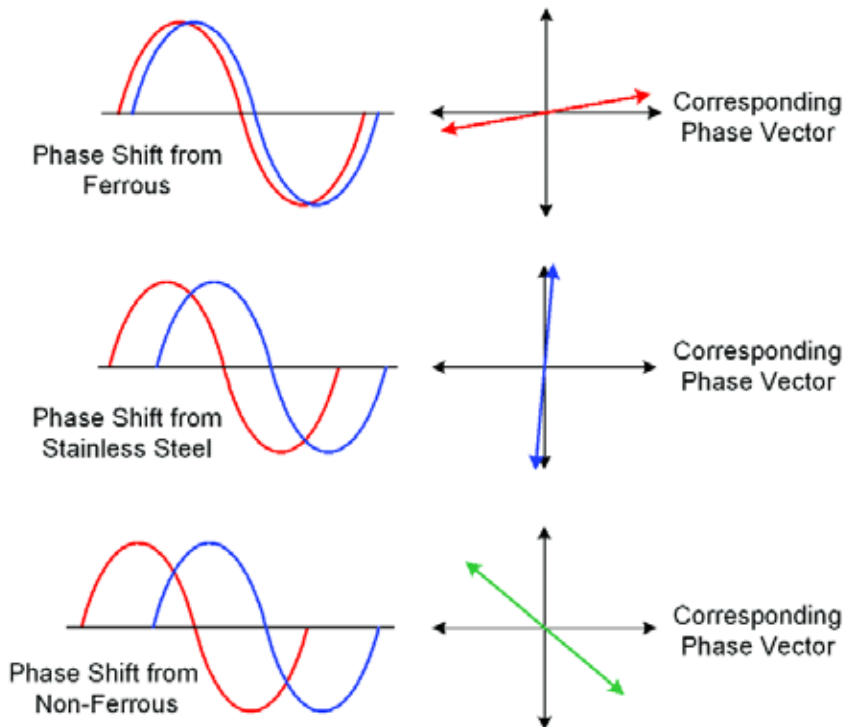

C. Vibration

Mechanical vibration introduced into the Former/Coil assembly vibrates the assembly and self induces a voltage back into the receiving coils that is processed.

Since the signal was not reflected back to the system by a material or substance, no phase shift occurs, and the resulting plotted vector is horizontal.

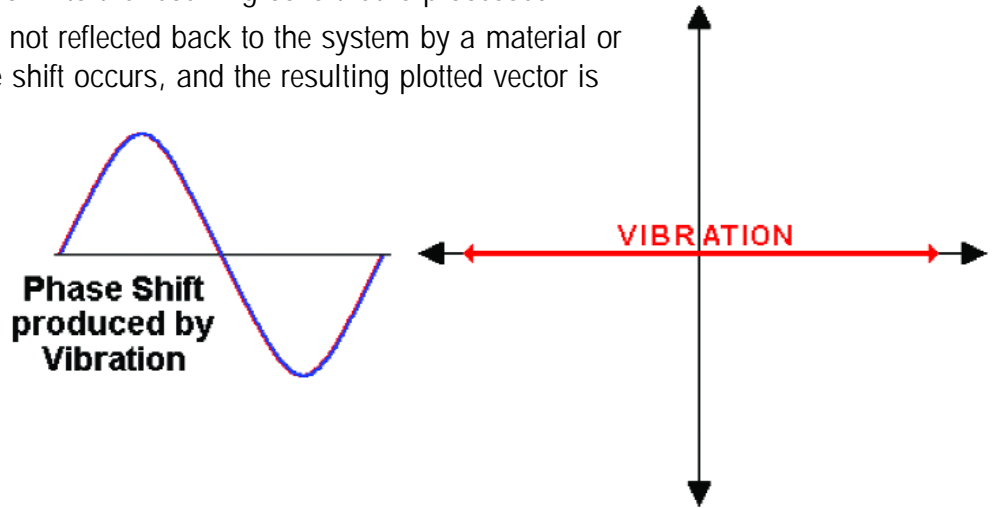

D. Reference Phase

One of the primary machine settings for the metal detector is the Reference Phase. It is important that this parameter be properly set to ensure optimum detector performance.

The system electronics has the ability to generate and control an electronic phase envelope that can be swept through a 180-degree range.

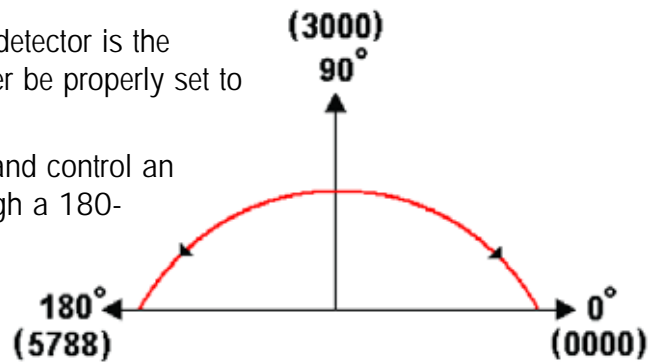

Any signal vector that is "captured" within the adjustable electronic envelope has the effect of reducing or "nulling" that particular signal.

Setting the Reference Phase aligns the electronic phase envelope to capture the horizontal signal from vibration, thus minimizing the effect of mechanical vibration.

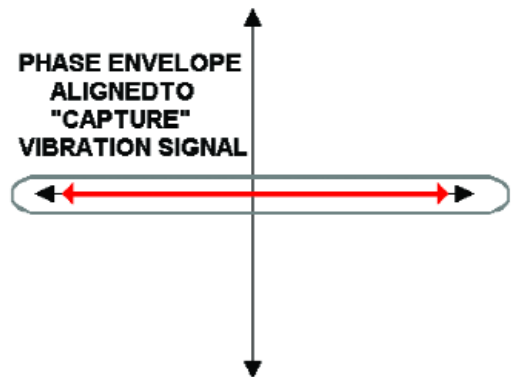

Once the Reference Phase has been properly established for the metal detector, it then provides a "base line" point by which all user product phase angles will be referenced.

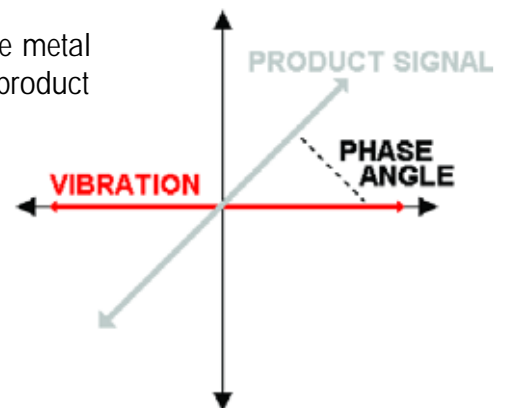

E. Product Phase

Some products generate strong signals as they pass through the detector. They interact with the high frequency electromagnetic field in the same way the metals interact. This is commonly referred to as "Product Effect" signals.

Typically, signals from product are categorized into two general classifications:

DRY:

- 1). VERY LOW MOISTURE CONTENT
- 2). SIGNAL PRODUCED IS VERY SMALL
- 3). CONTAINS LITTLE OR NO CONDUCTIVE PROPERTIES

WET:

- 1). VERY HIGH MOISTURE CONTENT
- 2). SIGNAL PRODUCED IS VERY LARGE
- 3). MAY CONTAIN HIGHLY CONDUCTIVE PROPERTIES

Usually, dry product does not require the use of Product Phase. Simple adjustment of the sensitivity control is all that is required.

Products that are wet and/or conductive require a more controlled set-up to avoid the metal detector from rejecting them as they pass through the coils. Simply reducing the sensitivity control may not completely eliminate the strong signal. What is required is a more selective method to "null" out the product signal, while still allowing for the best metal finding capabilities. The solution to this is the usage of the Product Phase Control.

Just as the Phase Envelope could capture and "null" the signal produced by vibration, the Product Phase Control can be user adjusted to capture and "null" the strong product effect signal.

Adjustment of the Product Phase Control aligns the envelope to the product signal instead of the vibration signal.

Note that while the product signal is now reduced, the movement of the envelope off the vibration signal now exposes the vibration vector and hence the detector is now more sensitive to the effects of mechanical vibration.

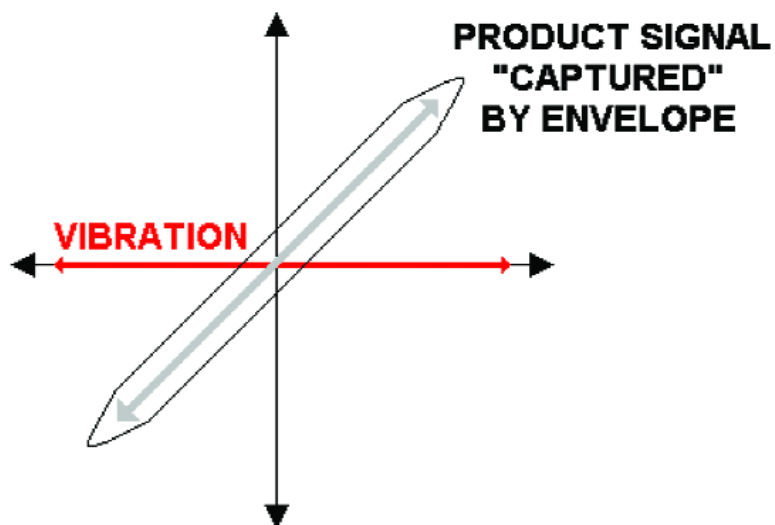

SYSTEM SOFTWARE LEVELS

3.1 KEYPAD FUNCTIONS

A. Detection LED

The detection LED will illuminate each time the bar graph display crosses from the last green segment to the first red segment. It will remain illuminated until the red segments cross back into the green again. The detection LED also serves as a fault indicator in the event of a fault condition.

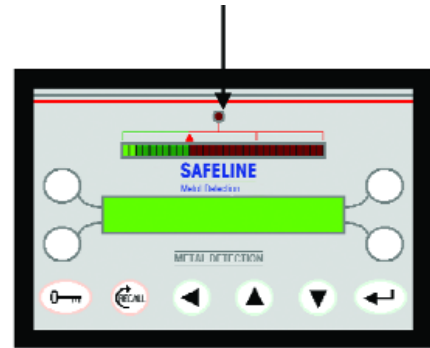

B. Bar Graph Display

The bar graph display is a 30-segment display consisting of 10 green segments and 20 red segments. Only signals that cross into the red section are considered detection. The bar graph provides the user with an accurate visual indication of signal size.

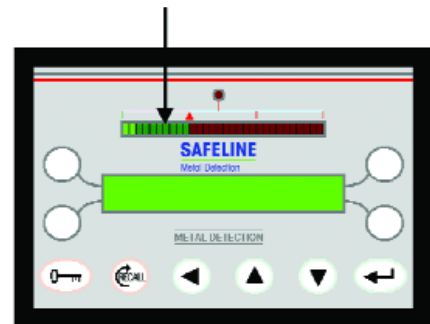

C. LCD Display

The LCD display provides the visual information about the system and performance parameters while viewing the various screens of the software program modes.

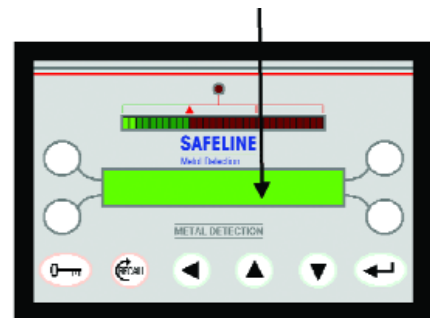

D. Soft Function Keys

Four soft keys are located adjacent to each corner of the LCD display. These keys permit access to the various adjustments in the program. If a particular parameter is user adjustable, an arrow will appear indicating adjustment is permitted.

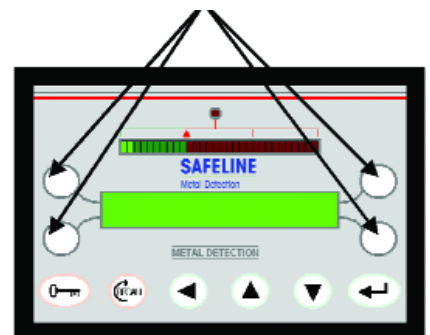

E. Security Key

The Security key allows access to the detectors program. Once the program has been edited, pressing the key again will exit the program and return to the running mode display.

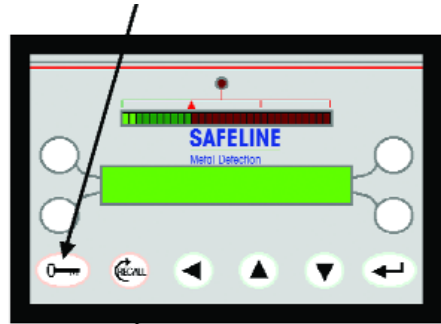

F. RECALL Key

The RECALL key provides system information when depressed from the running mode display. It also functions to step backwards when in the various program modes.

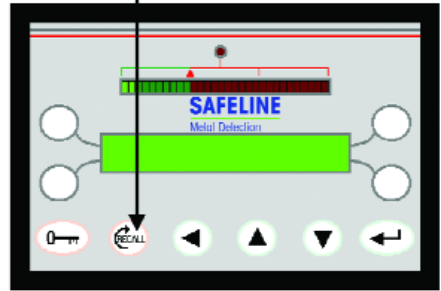

G. Cursor Move Key

The cursor move key controls the movement of the cursor when editing a digital value. The cursor move key always moves the cursor from right to left.

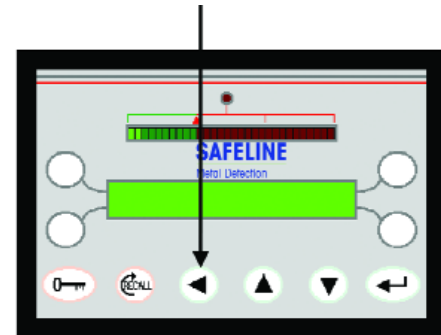

H. UP / DOWN Arrow Keys

The up / down arrow keys increase or decrease digital values that appear in the LCD display.

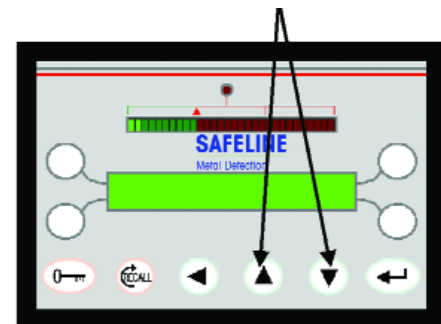

I. ENTER Key

The ENTER Key is used to enter changes into the system memory. If the enter key is not pressed after a digital value has been changed, the value will automatically default back to it's original value.

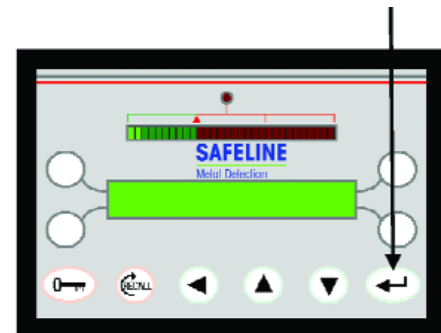

3.2 STANDARD USER LEVELS

POWERPHASE Systems User Program Modes

Program Mode Name	Default Security Access Code
1. Running Mode Display	No Access Code Required
2. Operators Mode	0001
3. Supervisor Mode	0002
4. Engineer Mode	0003
5. QA Inspector Mode	0004
6. QA Operator Mode	1000 through 9000
7. Viewing Mode	0005

(Note: These sections refer to the POWERPHASE Operating and Instruction Manual)

3.3 DIAGNOSTIC LEVEL

A. Description

Within each detector system is a diagnostic level that is frequently used by the factory technicians to aid them in system configuration, setup, and troubleshooting. This level is reserved only for trained personnel and should not be entered by anyone who is not trained and familiar with the detector system. Failure to adhere to this could result in a serious mis-adjustment of the detector rendering it ineffective.

B. Diagnostic Level Access

Press the program / exit key. Key in the following sequence:

1. With the cursor positioned under the zero in the thousandth's position, increment to the number 1 and press the "ENTER" key.
2. The thousandth's digit will turn to an asterisk, and the cursor will automatically position under the zero in the hundred's position. Increment to the number 2 and press "ENTER".
3. An asterisk will appear in the hundred's position, and the cursor will move to the ten's position. Increment to the number 3 and press "ENTER".
4. An asterisk will appear in the ten's position and the cursor will move to the one's position. Increment to the number 4 and press the "ENTER" key three times. (NOTE: This must be done in immediate succession or the program will cycle back to the running mode display).

Once the above sequence is completed, the second level of security screen appears.

5. The microprocessor will generate a random four-digit number that will change each time this level is reached. The objective is to enter in values that when subtracted will equal (4, 3, 2, and 1).

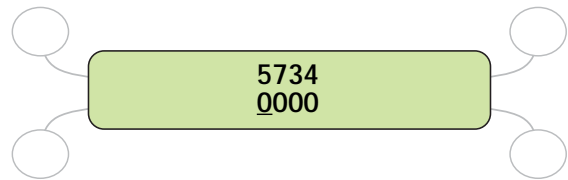

Using the example above, the numbers that would need entered are: (1, 4, 1, and 3). These numbers when subtracted from the example would yield the desired (4, 3, 2, 1).

NOTE: If the number you are trying to subtract is equal to or larger than the number generated enter 0 and continue to the next number.

In this example, some of the values generated are too small to subtract. The entered sequence would be: (5, enter, enter, and 5).

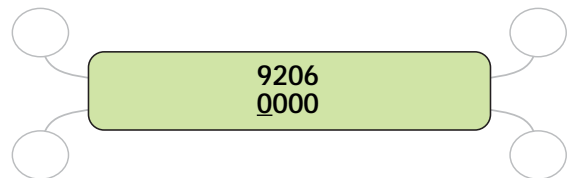

When the second security level is completed, the main diagnostic menu will be displayed.

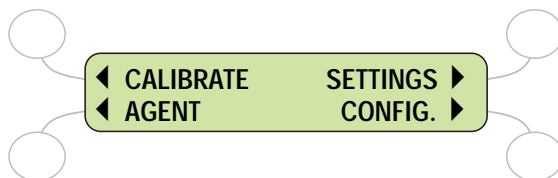

Powerphase Main Diagnostic Menu

3.5 Powerphase Diagnostic Menu

A. Agent

1). COM 1

Configures COM 1 port for the correct printer type. Selectable for: DOT MATRIX or TML60II.

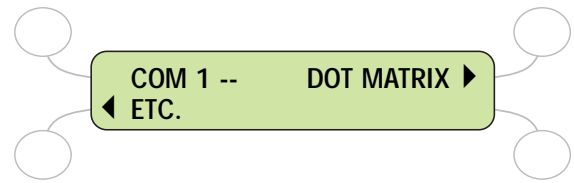

2). COM 2

Configures COM 2 port (RS-232). Selectable for: SAFELINE PCI or SNP (Safenet Plus).

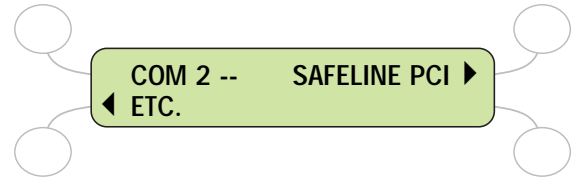

3). AUTO SETUP REJECT INHIBIT

Enables / disables reject inhibit during auto setup routine.

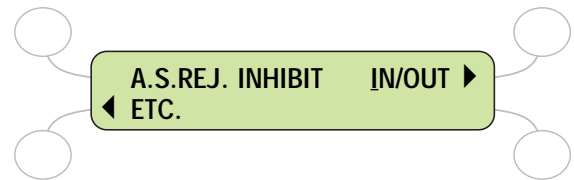

4). PERFORMANCE CHECK

Enables / disables the QA Inspectors level. If disabled, the QA Inspectors level will not be accessible.

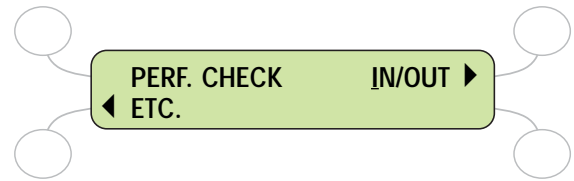

5). AUTO-TRACKING

Enables / disables auto-tracking feature. Feature is available for special limited applications



6). AUXILIARY 1 OUTPUT

Configures the AUX 1 output port. Selectable for alarm output if a system fault occurs, or continuous output if the detector is active (powered ON).

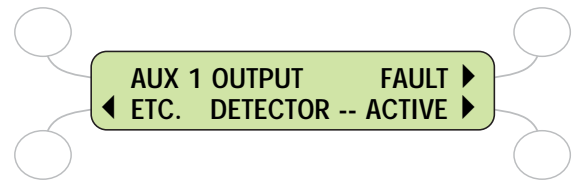

7). DIMENSIONS

Configures unit of measurement for calculations. Selectable for metric or imperial

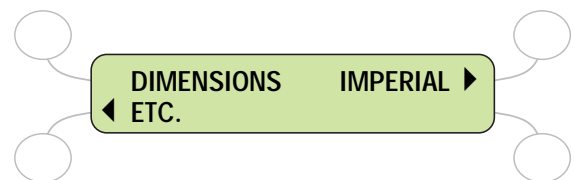

8). RESET TO DEFAULTS

Resets the system memory to default values. Consult with Safeline before initiating a reset.



B. Calibrate

1). SWITCHED FREQUENCY

Selectable for single or dual frequency operation. If single frequency operation is selected, the detector will default to the "HIGH" operating frequency.

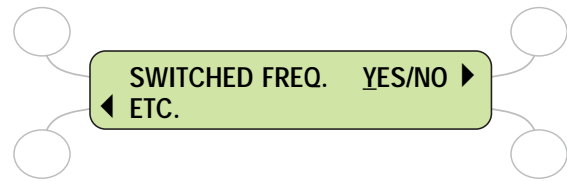

2). FREQUENCY GROUP AND FREQ. STAGGER

Selects the proper operating frequency group for the detector. It is very important to ensure the frequency group is correct for proper detector operation. The Frequency Stagger indicates the proper coding number for the crystal installed in the Control Module.



3). COIL PITCH

This is the distance between the coils. It is factory preset for each detector.

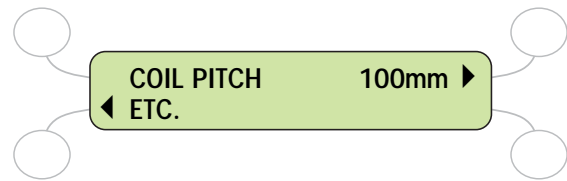

4). L.F. OFFSET

A real time voltage being read from the LF Amp board. A trimmer potentiometer on the back of the Control Module allows adjustment. Tolerance is plus or minus 010mv.



5). POWER DRIVE

Provides adjustment of the power drive voltage. The number in parenthesis is a real time readout of the power drive voltage. Selectable for both frequencies.

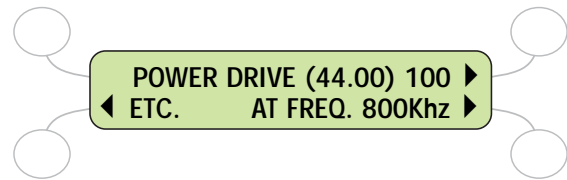

6). REFERENCE PHASE

Allows for adjustment of the reference phase. Sensitivity control is provided for signal level during adjustment. Selectable for both operating frequencies.

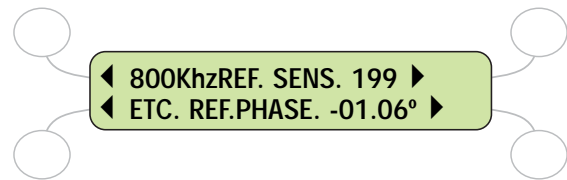

7). FERROUS PHASE

Provides minor adjustment to the reference phase to enhance sensitivities to ferrous metal.

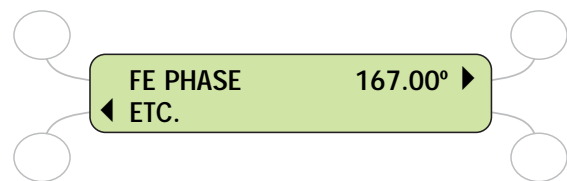

8). SENSITIVITY LIMIT

Limits the maximum sensitivity the detector will setup to during an auto setup routine if the phase is at the worst vibration position (90.00 degrees). Selectable for both operating frequencies.

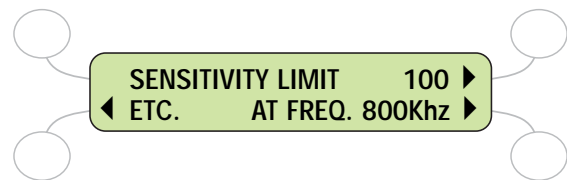

C. Configuration

1). SERIAL NUMBER

Allows programming of the search heads serial number.

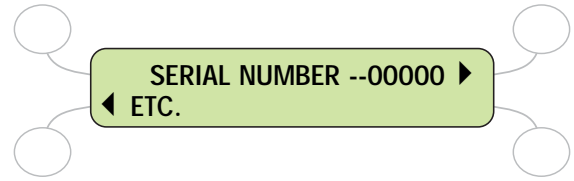

2). PEAK DISPLAYS

Enables / disables the peak displays. This provides a numerical readout of the peak level signals from the detector.

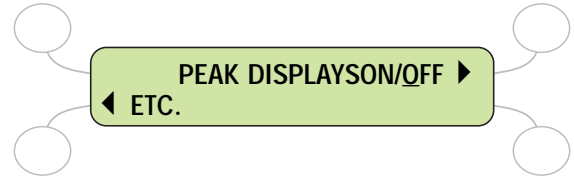

D. Settings

1). NAME & PRODUCT NUMBER

Allows user to name product numbers. Up to 14 characters long for the 21 product numbers.

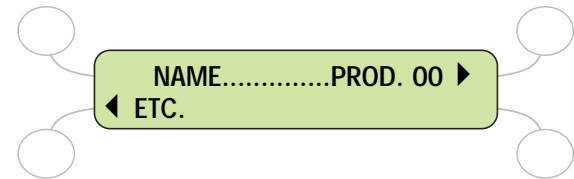

2). SENSITIVITY & PRODUCT PHASE

Allows adjustment of the detector sensitivity and product phase.

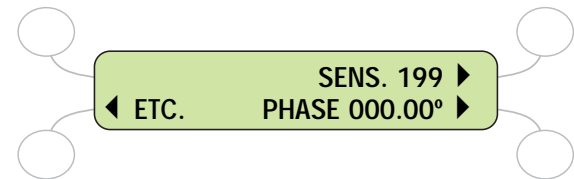

3). OPERATING FREQUENCY

Switches the detectors operating frequency.



4). POWER DRIVE

Adjusts power level to search head.
 HIGH = maximum power drive level
 LOW = reduces to 1/5 of the maximum power drive level

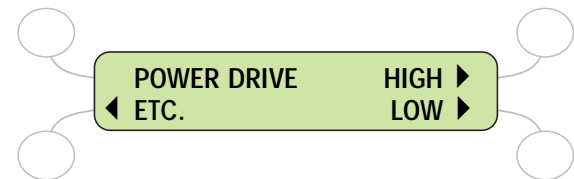

5). TIMERS

Accesses the timer sub-routine. Allows user to program the timer parameters. Selectable for 5 timer types. Any timer can be assigned to one of the three timer groups (A, B, or C).



6). INVERSE DETECTION

Switches inverse detection option on / off.)

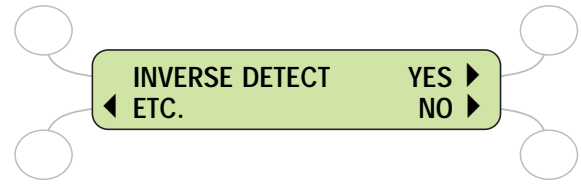

7). REJECT COUNT

Resets the reject count.
Maximum count level is 9999

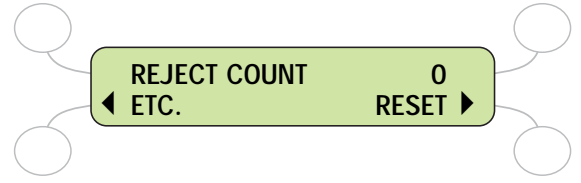

8). PACK COUNT

Resets the pack count.
Maximum level is 16,777,214.

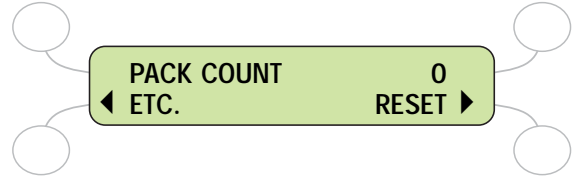

9). REJECT INHIBIT

Disables the reject device. A visual indicator alerts the user to the feature being engaged.

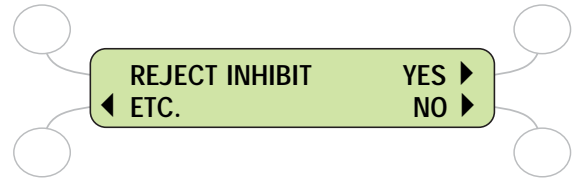

10). VIBRATION SETUP

Selection initiates the vibration setup sub-routine.

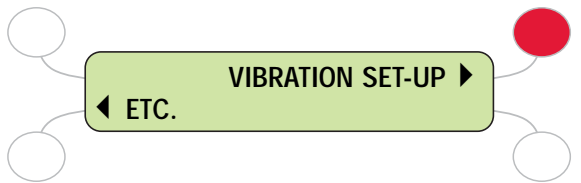

11). REFERENCE PHASE & REFERENCE SENSITIVITY

Adjustment of the reference phase. A reference sensitivity control is provided to control signal levels during the adjustment of the reference phase. Any adjustment to the reference phase in this screen only effects the operating frequency the detector is currently in.

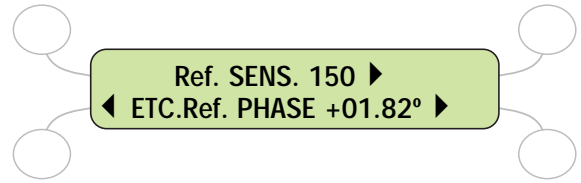

12). SENSITIVITY LIMIT

Sets the maximum sensitivity level that will occur during an auto setup routine if the phase is at its worst position (90.00 degrees). An auto adjust feature is provided for automatic setting. Best performed on-site where all ambient vibration is present.

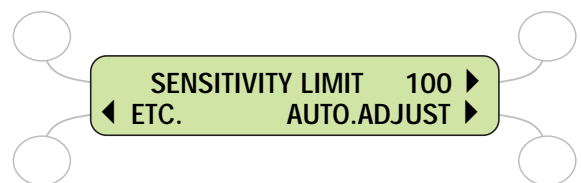

13). PACK SENSOR SETUP

Selection initiates pack sensor setup sub-routine. This must be setup if using a photo-gated timer.

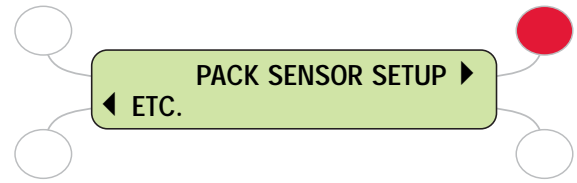

14). PACK SENSOR FITTED

Configures system for photo-gated operation. Selectable for enable / disable.



15). PACK SENSOR DISTANCE

Establishes the pack sensors distance. Measures from the leading edge of the detector case to the sensor. Maximum distance is 400 inches.

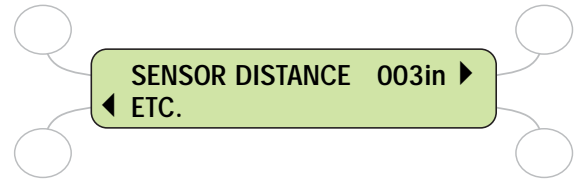

16). PACK SENSOR CALIBRATE

Calibrates the pack sensor. If the pack sensor fitted screen was selected to "yes", the system will proceed with the automatic calibration.

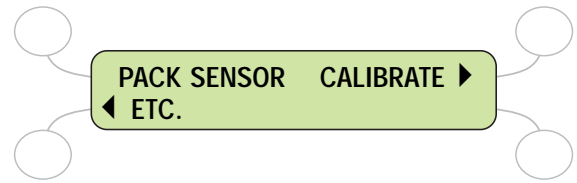

17). SECURITY SETUP

Selection initiates security setup sub-routine.

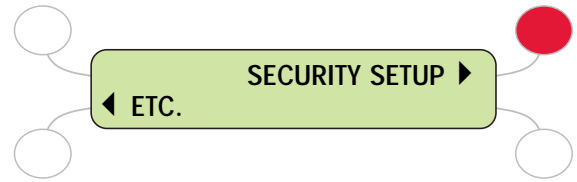

18). OPERATOR ACCESS

Restricts access to operators. Full access permits adjustment of product number, sensitivity, and phase. Limited permits only access to the product number.

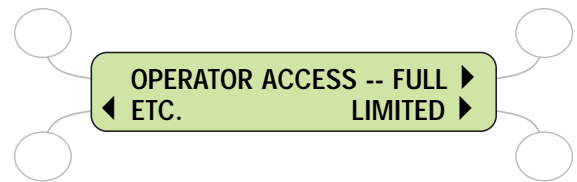

19). CHANGE CODE (OPERATOR)

Programs a custom four-digit security code for operator access.

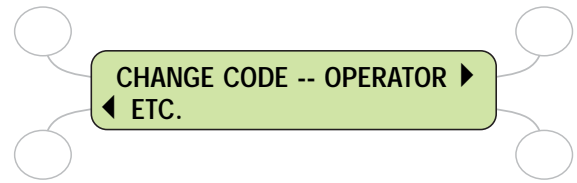

20). CHANGE CODE (SUPERVISOR)

Programs a custom four digit security code for supervisor access.

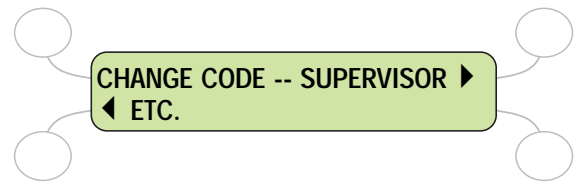

21). CHANGE CODE (ENGINEER)

Programs a custom four digit security code for engineer access.

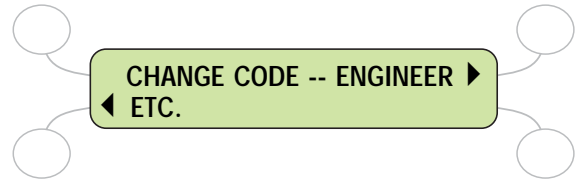

22). CHANGE CODE (VIEWING)

Programs a custom four digit security code for the viewing mode.



23). SPEED SETUP

Selection initiates speed setup sub-routine. Feature limited to fixed speed conveyor systems.

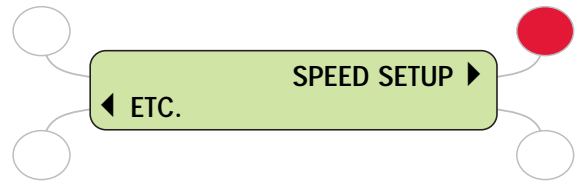

24). SPEED RANGE

Configures the detector for one of three speed ranges. Selection enables / disables the dynamic filter feature. The three selections are:

NORMAL: Selection activates the dynamic filter. This speed range selection is limited to fixed speed conveyors.

VARIABLE: Selection disengages the dynamic filter. Selected for variable speed conveyors.

FAST: Selection disengages the dynamic filter. Selected for gravity fall applications.

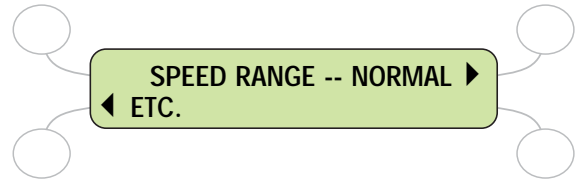

25). PRODUCT SPEED

Used with the (NORMAL) speed range selection to provide the detector with the exact product speed. It is highly recommended to use a tachometer to establish the precise belt speed and manually enter this value.

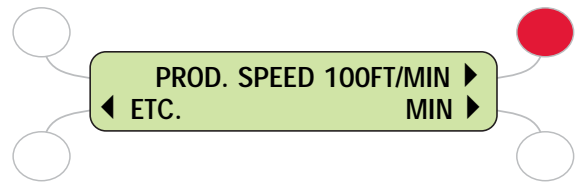

26). DETECTION BUZZER

Enables/disables the internal piezo audio indicator within the Control Module.

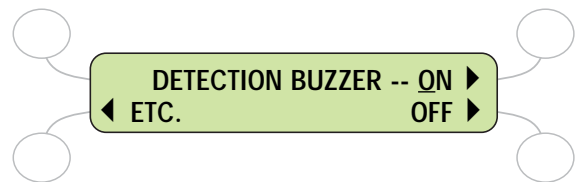

27). REJECT CONFIRMATION

Turns reject confirmation on or off. For this screen to appear in the menu, it must first be selected in the agent level. Requires additional hardware to function.

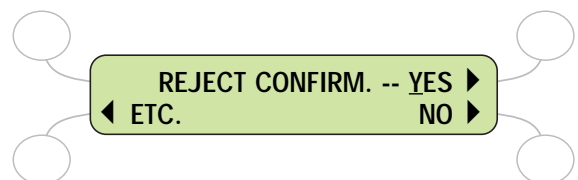

28). REJECT CONFIRMATION EXTENSION TIME

If reject confirmation is selected, allows adjustment of the extension time. The interval is the "wait period" that the circuit must hold for after a detection to register a rejection cycle.

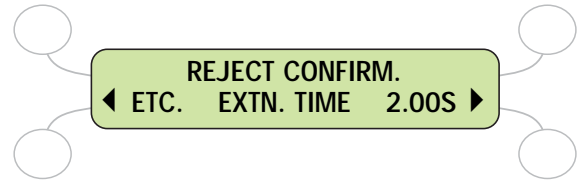

29). BOOST MODE

If selected in the agent mode, this screen will appear in the Engineering menu. Boost enhances sensitivity by re-scaling the bar graph display. Limited applications.

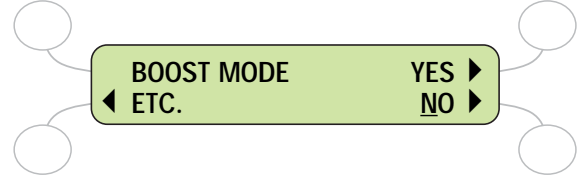

30). BOOST WINDOW & THRESHOLD

If boost is selected, parameters support the boost mode.

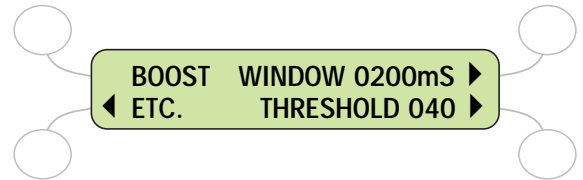

31). LANGUAGE

Selects different languages. Selections include: English French German Spanish Dutch Italian Swedish Danish Japanese Polish

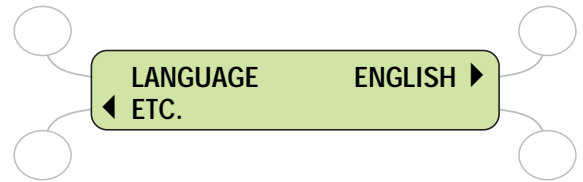

32). SET THE DATE AND TIME

Sets the date and time (24-hr. clock format).

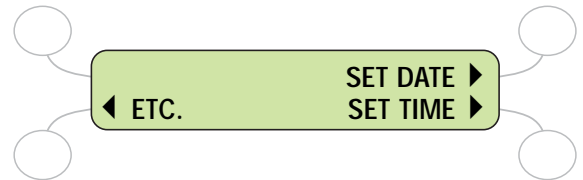

USER SETTINGS AND ADJUSTMENTS

4.1 PRODUCT SETUP

A. Description

Products are typically classified into two groups, dry and wet.

Most dry products have very little effect when passing through the detector. Only minor adjustments to the sensitivity allow these products to run. Examples of dry product include, unenriched flour, white sugar, some cereals, baby diapers, baking powder, etc.

The product has little conductive properties, the signal produced is mostly resistive.

Signals generated in this fashion are often referred to as "bulk effect" signals.

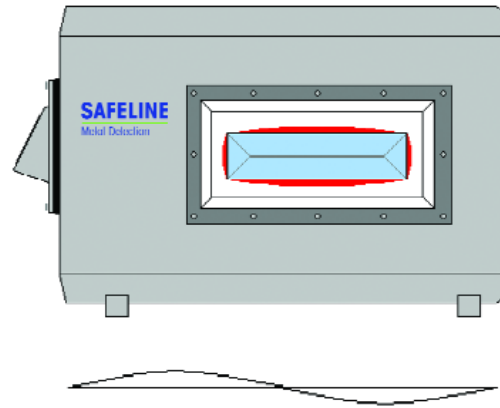

Wet products usually have high moisture content and often contain other conductive elements such as water, salt, acids, high mineral content, etc. Some examples of these include fresh meats, fresh breads, brown sugar, cheese, soups, etc.

Wet products require the detector to have more than just the sensitivity adjusted. What is required is a combination of frequency selection, sensitivity, and product phase to enable the product to pass un-detected while still maintaining a search for metal contamination. The product has a substantial "product effect" signal due to its high conductive elements. Both sensitivity and product phase will be required to allow this product to pass through the metal detector.

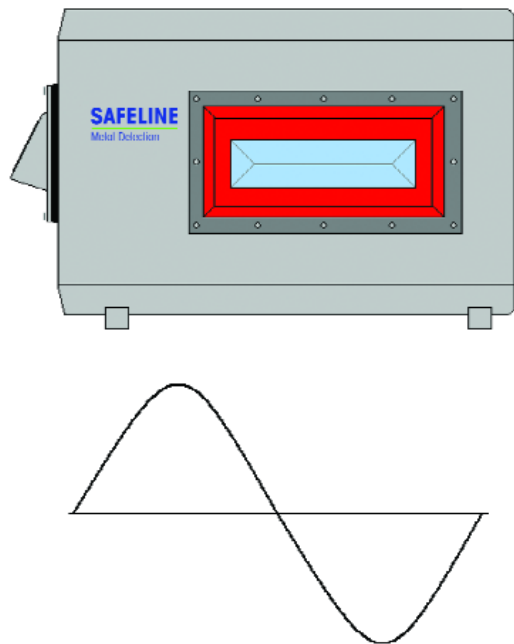

Waveform produced is large

B. Product Setup

1. See page 29-37 of this manual

4.2 REJECT TIMER SETUP

A. Description

The detector has 5 timer types that are assignable to any of the three timer groups (A), (B), or (C). The timers can be assigned to any of the 21 product numbers. These timers cover all the various detector configurations and applications.

TM1 - Simplest timer. Actuates reject instantly upon a detection.

TM2 - A delayed reject timer. Used for fixed speed conveyors. Accuracy is subject to the position of the metal contaminate.

TM2(G) - A delayed timer that requires a photo sensor for package position. Used for fixed speed conveyors. Highly accurate for discrete package rejection.

TM3 - Similar to TM2, but designed for variable speed conveyor systems.

TM3(G) - Similar to TM2(G), but for variable speed conveyors.

B. Timer Setup

1. See page 38-57 of this manual.

4.3 VIBRATION SETUP

A. Description

This feature configures the sensitivity limit used by auto setup routine

B. Setting and Adjustments

1. Automatic Adjustment (See POWERPHASE Operating and Instruction Manual).

4.4 Pack Sensor Setup

A. Description

This feature configures the detector for a package sensor. Must be preset before proceeding with a photo-gated timer such as TM2(G) or TM3(G). Pre-calibrating the sensor speeds up photo-gated timer setups.

B. Setting and Adjustments

1. (See POWERPHASE Operating and Instruction Manual).

4.5 SECURITY SETUP

A. Description

Allows user to program custom security access codes for each of the different software levels. Levels and factory default codes include:

- 1). Operator (0001)
- 2). Supervisor (0002)
- 3). Engineer (0003)
- 4). QA Inspector (0004)
- 5). Viewing (0005)

4.6 SPEED SETUP

A. Description

This feature configures the detector for correct product speed. Enables enhanced sensitivity performance utilizing a dynamic filter circuit. Three selectable product speed ranges:

- 1). normal - Selects dynamic filter. For fixed speed conveyors.
- 2). variable - Disengages dynamic filter. For variable speed conveyors.
- 3). fast - Disengages dynamic filter. Used for gravity fall applications.

4.7 AUTOMATIC TRACKING

A. Description

The automatic tracking feature measures the signals from discrete products and adjusts the phase and sensitivity to compensate for small changes over time. Three parameters are adjustable:

- 1). Maximum Rate: Sets the maximum rate the phase is allowed to change between two successive packs.
- 2). Maximum Span: The maximum phase value that the phase may deviate from the original phase setting.
- 3). Damping: determines how quickly the tracking react to changes in sensitivity and phase.

4.8 Q.A. SETUP

A. Description

The QA-setup configures the detector for the performance validation routine and printing capabilities. The setup and programming is done through the QA Inspector mode menu. It is important to remember that this level will only appear if selected in the "Agent" menu of the diagnostic level.

B. QA Setup

1. See page 66-72 of this manual

4.9 REJECT CONFIRMATION

A. Description

Reject confirmation is an option that confirms the positive operation of the reject mechanism. Requires additional hardware.

B. Reject Confirmation Setup

1. See page 62-65 of this manual

4.10 INVERSE DETECTION

A. Description

The inverse detection feature reverses the normal operation of the detector by scanning for the presence of a metallic premium and rejecting product without metal in it.

Requires the use of a photo-gated timer.

B. Inverse Detection Setup

1. See page 58 of this manual

4.11 PRODUCT NUMBERS

This section will show the user how to change Product Numbers, which Pass Codes allow access and how many product numbers are available.

There are 21 product numbers available from 00 to 20. Each product number will hold a complete set of information connected with a particular product group / package. The idea of selecting product numbers allows quick and easy change of one product group to another saving the time of line operators.

Product number selection is pass code protected, the user groups allowed to change the 'product number' are:

- Operators
- Supervisors
- Engineers

A. Changing a Product Number

As an example lets say the Operator wishes to change the Product Number from 00 to 10, the first task is to Enter the Operator pass code, once the code has been entered correctly the display will change to show...

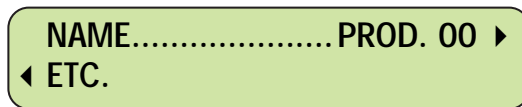

This display shows that the product number only can be changed as indicated by the arrow next to the text.

To make an adjustment the soft-key adjacent to the arrow 4 must be pressed, when this is done the arrow will flip over and a cursor will appear underneath one of the digits, this indicates that this parameter can be adjusted.

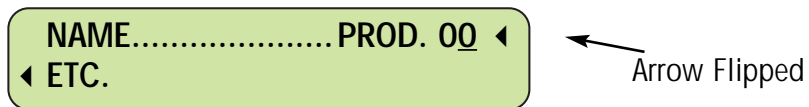

Using the cursor move key position the cursor under the first digit of the product number as shown here:

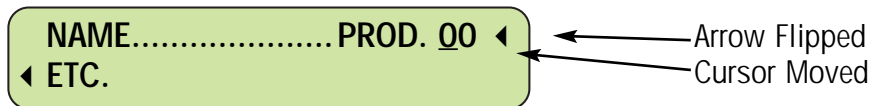

Using the "UP key ▲" press once to increase the digit to 1, press the ENTER key to store this number. The arrow will now flip back and the cursor will clear.

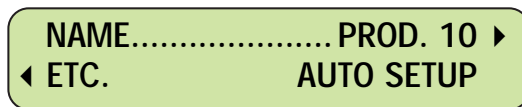

This action has now changed the Product Number to 10, all the information associated with Product No: 10 has been selected.

Press the PROG/EXIT key to exit and return to the running mode display.

4.12 SENSITIVITY CONTROL

This section will show an example of the Sensitivity being set too high and as a result good product being rejected. It will show how the Sensitivity is adjusted and which pass codes allow access.

The Sensitivity can be adjusted from a minimum value of 000 to a maximum value of 199
The Sensitivity is used to control the detection level of the metal detector. If the sensitivity is set too high then false detection's can occur which result in unwanted product being rejected, if the level is set too low then metal contaminants may not be detected. The Sensitivity is set to a value that will easily detect the 'Calibrated Test Samples' but not detect / false trigger off the product itself.

The Sensitivity Control is pass code protected, the user groups allowed to adjust the Sensitivity are:

- Operators (if access is FULL, when set from the Engineering Mode)
- Supervisors
- Engineers

A. Adjusting The Sensitivity Control

Example:

Lets say that the sensitivity has been set too high and quite a lot of good product is being rejected, but the test samples are being detected easily.

The Sensitivity is set at 199 and needs to be reduced to 190, the SUPERVISOR will make the adjustment, the first task is to Enter the supervisor pass code.a

The following sections assume that the Supervisor has Entered the Supervisor Mode using the correct Pass Code.

When the code has been set and Entered the display will change to show...

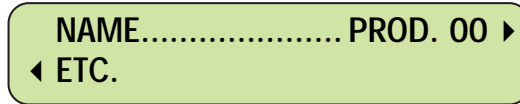

The soft key next to ETC is pressed, the display will show

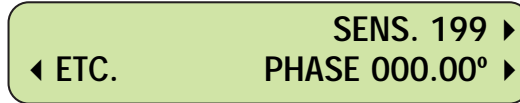

To adjust the sensitivity the soft-key adjacent to SENS is pressed, this will cause the arrow to flip over and point to the text, also a cursor will appear under the number 9 as shown below:

This arrow has flipped over and a cursor has appeared



To reduce the number from 199 to 190 the 'DOWN' arrow key is pressed nine times this will reduce the number to 190 reducing the sensitivity as required, the display will show:

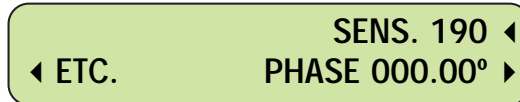

To store this new setting into the computer memory the ENTER key is pressed, this will cause the arrow to flip back to its original position and the cursor will disappear, the display will show:

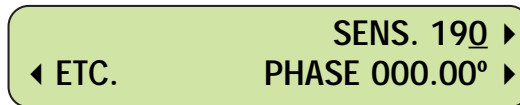

Using the test samples, the metal detector is now tested to verify that the adjustment was successful, if not re-adjustment may be required.

Press the PROG/EXIT key to exit and return to the running mode display.

4.13 PHASE CONTROL

This section will show an example of the Phase being set incorrectly and as a result good product being rejected. It will show how the Phase is adjusted and which pass codes allow access.

Some products when passed through a metal detector cause a detection to occur resulting in the item being rejected from the production line. The signal being generated from the product is known as 'Product Effect'.

The Phase setting, which is sometimes referred to as the 'product compensation' control, is used to control the Product Effect signal.

The Phase setting can be either automatically or manually adjusted from a value of 000.00° to 180.00°.

Typical products that will exhibit this effect are:

- Cheese
- Mint Sauce
- Fresh Chicken Breast
- Red Meat
- Salad Dressing
- Metalized Film Packaging

The above products are sometimes referred to as WET products.

When a WET product is passed through the metal detector with the Phase set to 000.00° the product effect signal can easily be seen on the bar-graph display.

The object is to set the Phase control until the signal shown on the bar-graph is at a minimum. For most applications the Phase value will lie between 80.00° and 100.00°.

The Phase control is pass code protected, the user groups allowed to adjust the Phase are:

- Supervisors
- Engineers

The following sections assume that the pass code has been Entered and the Product Number selected by one of the above user groups

Note: The PHASE control is not available in Product Number 00

A) Adjusting The Phase Control

Before the phase is adjusted automatically the conveyor belt must be checked to make sure that it is free from any contamination. To do this set the product No to '00' and adjust the sensitivity to '199', now observe the deflection on the bar-graph display first with the belt stopped and again with the belt running, the deflection should remain the same as shown below...



If the above condition is not met, i.e. there is a clear contamination signal that is seen to be repeatable, then clean the conveyor belt or replace it.

1) Automatic Mode

Once it has been decided that a product exhibits a product effect, the next step is to set the Phase control. Firstly the Pass code is Entered and the display will show:

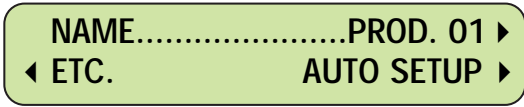

NOTE: A sample of the product must be ready before the next step is carried out.

To begin the automatic set-up the Auto-Setup soft-key is pressed, when this is done the metal detector will guide the user on the steps to take, on pressing the soft-key the first display will show:

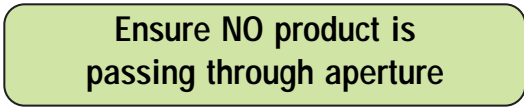

While this display is shown note that the bar-graph display may flash (if configured) at the far right Red area indicating that the reject device is inhibited, after approximately six seconds the display will show:

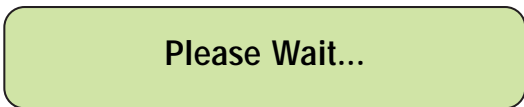

After approximately Five seconds the display will change to show:

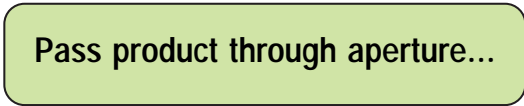

The product sample is now passed through the metal detector aperture at the correct speed, position and orientation.

If the signal measured by the metal detector was too large then the display will show:

**Product signal too large
please wait...**

After which it will ask the user to pass the product again. However if the signal was of the required size then the display will show:

**Adjusting
Phase...**

Followed by...

Please Wait...

The user will be asked to pass the product again ...

Pass product through aperture...

After approximately Five seconds the display will change to show:

**Product signal too large
please wait...**

After which it will ask the user to pass the product again. However if the signal was of the required size then the display will show:

Adjusting Sensitivity...

After approximately Five seconds the display will change to show one of the following messages:

**WARNING phase signal
may be in error**

This display may appear if the product signal level was very small, if so the Phase will have to be checked and may require Manual adjustment.

The final display will then be shown to indicate that Automatic set-up has been successful.

Product Adjustment Completed

The display will return to the Engineer or Supervisor Mode and the bar-graph display will return to normal.

2) Adjusting The Phase Control - Manual Mode

Firstly the Pass code is Entered and the display will show:

NAME..... PROD. 00 ▶
◀ ETC.

The soft-key next to ETC is pressed, the display will show:

SENS. 199 ▶
◀ ETC. PHASE 000.00° ▶

the soft-key next to phase is pressed, the display will show:

SENS. 199 ▶
◀ ETC. PHASE 000.00° ◀

Note that the arrow adjacent to PHASE has flipped over to point towards the text and a cursor has appeared under the ones digit.

The object is to set the Phase Value to obtain the minimum product effect signal as indicated on the bar-graph display.

Firstly set the Phase value to 90.00° by moving the cursor to the tens digit using the Cursor Move key, then set the digit to '9' by pressing the UP key nine times, the display will show...

SENS. 199 ▶
◀ ETC. PHASE 000.00° ▶

Next take the product sample and pass it through the metal detector aperture at the correct speed and orientation noting the signal level on the bar-graph display.

The Sensitivity is now adjusted so that the product signal gives approximately half deflection on the Red segment of the bar-graph, as shown below...



From the display shown below select sensitivity by pressing the soft-key next to SENS.

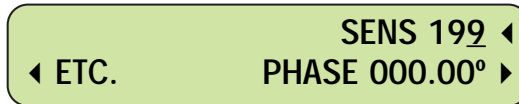

The Sensitivity is adjusted using the UP/DOWN keys to give the above deflection when the product sample is passed through the metal detector aperture.

The Phase value will now be adjusted so that the deflection observed on the bar-graph is reduced to a minimum. From the following display select PHASE.

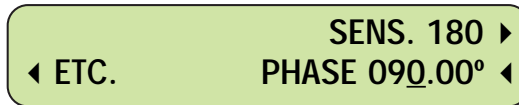

The arrow adjacent to Phase will flip over and the cursor will re-appear under the right hand digit indicating that the Phase control can be adjusted.

Now pass the product through the metal detector aperture and observe the deflection on the bar-graph display - note this deflection. Using the UP arrow key increase Phase value to 91.00° and pass the product through the aperture again, observe and note the deflection on the bar-graph.

If the deflection signal has reduced then increase the Phase value to 92.00°, pass the product again and observe the deflection on the bar-graph.

If the deflection signal has increased then reduce the Phase value to 89.00°, pass the product again and observe the deflection on the bar-graph.

Repeat this procedure until the deflection signal reduces to a minimum, if the Phase value is adjusted from this point then it will be seen that the deflection on the bar-graph will also increase. This minimum value is known as the 'null' point.

As an example say that the minimum product effect signal has occurred at 91.00° and starts to increase again at 90.00°

At this stage the product effect signal observed on the bar-graph is quite small. To obtain a more precise Phase setting increase the Sensitivity value to obtain a larger signal indicated on the bar-graph display.

By the use of the 'Tenths' digit increase the Phase value (e.g.: 91.00°, 91.10°, 91.20° etc.) until the product effect signal has reduced to a minimum and then just starts to increase again. Using the Tenths digit adjust the Phase value UP and DOWN until the minimum signal is found - this is the 'NULL' point.

The Phase value is now aligned to the product signal, next adjust the Sensitivity so that the product gives a deflection of 2 to 3 Green Bars maximum on the bar-graph display, as shown below....

Bar-Graph Normal Display



Bar-Graph with Product showing 2 Bar deflection



The final test is to check the metal detector will not detect/trigger due vibration caused by shock - this is done by tapping the outer case of the metal detector and by operation of the reject device while observing the bar-graph, if this is unacceptable the Sensitivity is reduced to an acceptable level.

The Enter key is pressed to store the settings in the computer memory.

Using the metal test samples with the sample product check that a detection occurs with metal test samples but no detection occurs on the product itself.

4.14 REJECT TIMERS

Once the metal detector has detected a metal contaminant the normal action is to reject the infected product from the production line. There are many ways to reject contaminated products using various reject devices, the metal detector has a wide choice of reject timers to control a variety of reject devices.

The timer types are:

tm1basic reject timer without a delay.

tm2has a delay timer and a reject timer.

tm2[G]has a delay timer, a reject timer and a photo-gated pack detector .

tm3has a delay timer and reject timer which are externally controlled from a speed / movement sensor.

tm3[G]has a delay timer, reject timer and a photo-gated pack detector which are externally controlled from a speed / movement sensor.

The timers are pass code protected and are only available to the Engineer via the Engineering pass code.

A) TIMER tm1: Simple Reject Timer without Delay Time.

This reject timer is used when on detection of metal the reject device must operate immediately and stay in the reject position for a period of time until the metal contaminant has been rejected.

Typical Applications:

Conveyor Stop on detection with timed audible alarm. The conveyor would STOP immediately on detection of metal and an audible alarm would sound for a period of time set by the reject timer.

Diverter rejecters used on Gravity Fall and Pharmaceutical systems. The reject diverter would operate immediately on the detection of metal and stay in the reject position for a period of time set by the reject timer.

Timed Audible Alarms. Used when product is passing through the metal detector on a chute with no reject device. On detection of metal an audible alarm would sound to indicate to the operator that a contaminant has been detected, this alarm would operate for a period of time set by the reject timer.

1) Setting and Adjusting Timer tm1

Once the Engineer has entered the Engineering pass code the display will show...

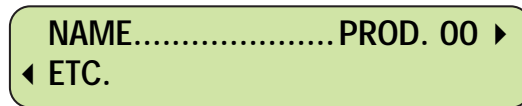

Next the Sensitivity must be checked to make sure that the signal generated by the metal test sample causes a maximum of Two Red bar deflection on the bar-graph as show below...



Adjust the Sensitivity so that this condition is met, the metal detector timer must only be adjusted to the smallest detectable metal test sample otherwise it may be possible to miss rejecting metal contaminants even though they were detected.

Once the Sensitivity has been adjusted, press the ETC soft-key to move down the menu system, the until display shows...

◀ A (Select Timer) B ▶
 ◀ ETC. C ▶

Now select one of the timer locations A, B or C, for this exercise select A by pressing the soft-key next to A. The display will change to show...

Timer "A" type YES ▶
 tm XX UPDATE NO ▶

As the object is to adjust this timer the soft-key next to YES is pressed, the display will change to show...

◀ tm1 (TIMER tm2 (G) ▶
 ◀ ETC. type) tm3 (G) ▶

Next select timer type, as we are working with timer tm1 press the soft-key next to tm1, the display will change to show...

tm1 REJECT TIME 1.00s ▶

This display will show the Reject Time set value for timer tm1, in this example it is set to 1 second (1.00s)

Using a test sample adjust the Reject Time until the sample is rejected correctly or the audible sounder is heard.

To do this press the soft-key next to REJECT TIME, this will cause the arrow to flip over and a cursor will appear under the reject time value indicating that this figure can be changed, the display will show...

tm1 REJECT TIME 1.00s ◀

In the case of a Gravity Fall or Pharmaceutical system, drop the metal test sample through the metal detector aperture and observe the operation of the reject device.

The reject device should operate immediately upon detection, stay in the reject position until the contaminant has been rejected then return to the normal accept position.

Example: The Reject Time is too short and the contaminant is not being rejected correctly, the value needs to be increased to 1.50 seconds to make sure that it is rejected correctly.

To adjust the Reject Time value from 1.00s to 1.50s move the cursor to the second digit and using the 'Up' arrow key change the digit to 5 by pressing the key Five times, the display will show...

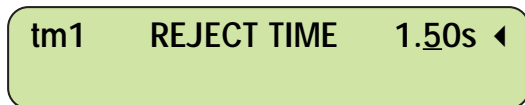

tm1 REJECT TIME 1.50s ◀

Using the test sample check that the reject device now operates for the correct time and the sample is rejected correctly.

Now press the ENTER key to store this value, this will cause the arrow to flip over and the cursor will disappear.

Press the ENTER key again to allocate this timer to the product number, the display will show...

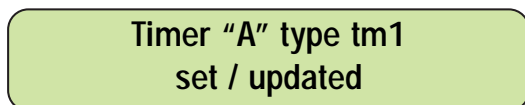

Timer "A" type tm1
set / updated

This display will appear for approximately 5 seconds after which it will return to display the [Select Timer] menu.

Press the PROG / EXIT key to return to the running display.

B. TIMER tm2 (G): Delay Time, Reject Time and photo-gated Pack Detector.

This reject timer is used when the reject device is positioned some distance from the metal detector, usually on conveyor systems. This application requires a DELAYED REJECT TIMER, upon detection of a metal contaminant the reject device will not operate until the contaminated product reaches the reject area, at this time the reject device will operate for the period of time controlled by the Reject Time.

The following drawing shows a typical metal detector conveyor system incorporating a pusher reject system, note that the rejecter is positioned a distance from the metal detector and that 'good product' is between the metal detector and the rejecter. The object is to reject the contaminated product and accept the 'good' product.

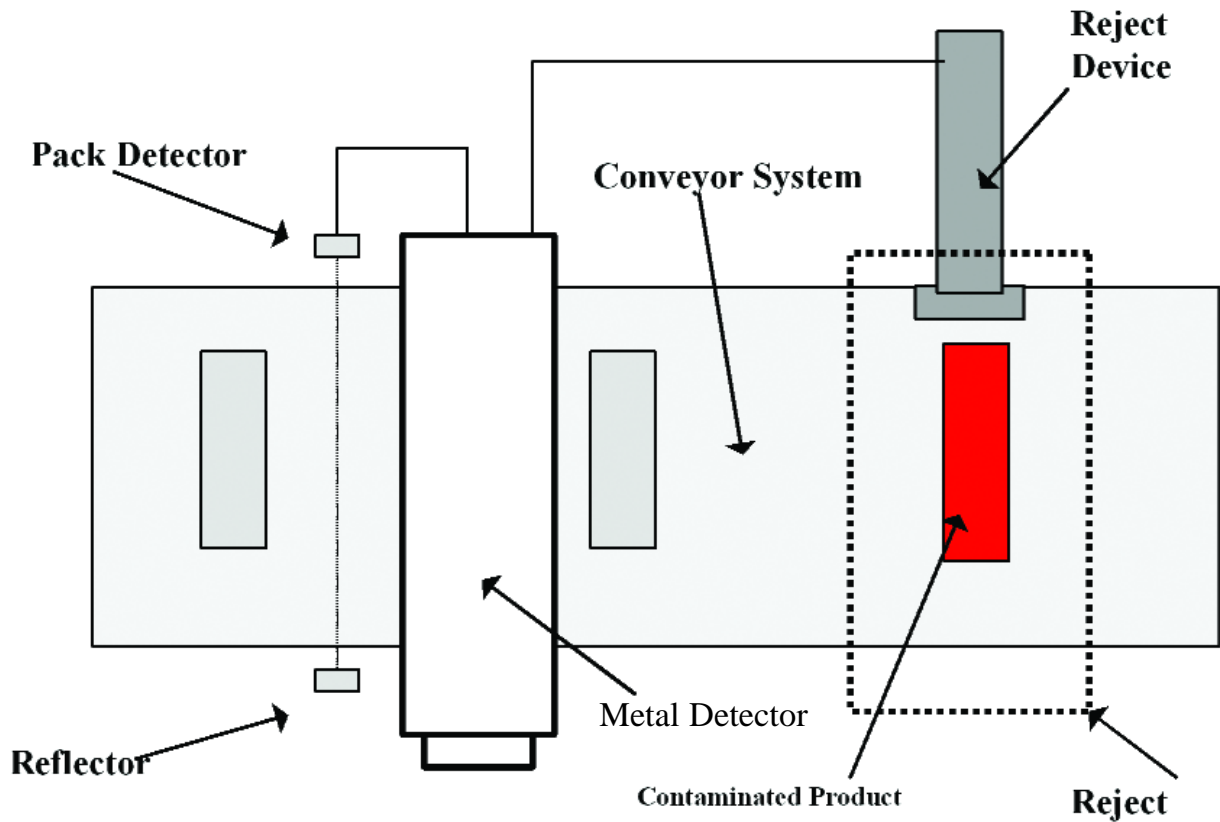

Timer tm2[G] can be used with or without a photo-gated pack detector, the pack detector is used to identify the position of the contaminated package to give pin-point accuracy for rejection.

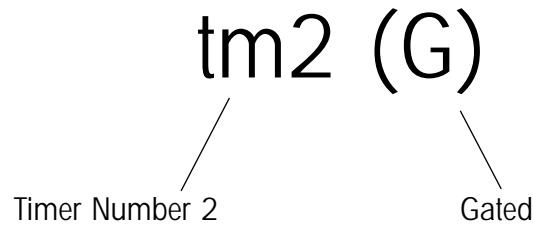

TIMER tm2 - NON GATED MODE

1.) Setting and Adjusting Timer tm2

Once the Engineer has entered the Engineering pass code the display will show...



Next the Sensitivity must be checked to make sure that the signal generated by the metal test sample causes a maximum of Two Red bar deflection on the bar-graph as show below...



Adjust the Sensitivity so that this condition is met, the metal detector timer must only be adjusted to the smallest detectable metal test sample otherwise it may be possible to miss rejecting metal contaminants even though they were detected.

Adjust the Sensitivity so that this condition is met, the metal detector timer must only be adjusted to the smallest detectable metal test sample otherwise it may be possible to miss rejecting metal contaminants even though they were detected.

Once the Sensitivity has been adjusted, press the ETC soft-key to move down the menu system, until the display shows...

◀ A	(Select Timer)	B ▶
◀ ETC.		C ▶

Now select one of the timer locations A, B or C, for this exercise select B by pressing the soft-key next to B. The display may change to show...

TIMER "B", TYPE	YES ▶
tm1 UPDATE?	NO ▶

As the object is to adjust this timer the soft-key next to YES is pressed, the display will change to show...

◀ tm1	(Timer	tm2	(G) ▶
◀ ETC.	type)	tm3	(G) ▶

Next select timer type, as we are working with timer tm2 press the soft-key next to tm2[G], the display may show...

Gated timer still	YES ▶
required?	NO ▶

If this display is shown press the NO soft-key, the display will change to show...

tm1	SIGNAL DELAY	1.00s ▶
tm1	REJECT TIME	1.00s ▶

This display shows the Signal Delay Time set value and the Reject Time set value for timer tm2, in this example they are both set to 1 second (1.00s).

Using the prepared test packet, pass the pack through the metal detector aperture at the correct speed and orientation with the sample positioned at the rear / trailing edge of the pack, note the operation of the reject device.

On individual products the reject device must operate just as the Front Leading Edge of the pack reaches the reject device, from this test it was observed that the reject device operated too early therefore the Signal Delay needs to be increased.

For this example the Signal Delay has to be increased to 3 seconds.

From this display press the soft-key next to SIGNAL DELAY, this will cause the arrow to flip and a cursor will appear under the right hand digit indicating that this value can be adjusted. The display will show...

tm2 SIGNAL DELAY 1.00s ◀
REJECT TIME 1.00s ▶

Next use the Cursor Move Key to position the cursor under the right hand digit, now press the UP arrow key Three times to change the Signal Delay to 3.00s, the display will show...

tm2 SIGNAL DELAY 3.00s ◀
REJECT TIME 1.00s ▶

Use the test pack to make sure that the adjustment made causes the rejecter to operate just before the front leading edge of the packet, if not re-adjust the Signal Delay.

Press the ENTER key to store this new value in memory.

Now the Reject time will be adjusted to a time long enough to reject the package, but not too long as to reject multiple packs.

As an example say that the Reject time was too long at 1.00 second and needs to be reduced to 500ms (500 milli-second = 0.5 second), so the reject time has to be reduced.

Press the soft-key next to REJECT TIME this will cause the arrow to flip over and a cursor will appear under the right hand digit indicating that this figure can be adjusted, the display will show...

tm2 SIGNAL DELAY 3.00s ▶
REJECT TIME 1.00s ◀

Using the cursor move key position the cursor under the second digit and using the 'down key' adjust to read 0.50s (500ms).

Pass the packet containing the metal test sample at the rear / trailing edge and check that the reject device operates at the correct time and for long enough to cleanly reject the pack.

Press the ENTER key to store this new setting into memory, the display will show...

tm2 SIGNAL DELAY 3.00s ▶
REJECT TIME 0.50s ▶

Press the ENTER key again, the display will show...

tm2 Gated? YES ▶
NO ▶

As this section is for the Non-gated Mode of operation press the soft-key next to NO, the display will show...

**Timer "B" type tm2
set / updated**

This display will be shown for approximately 5 seconds after which the user will be returned to the main menu.

Press the PROG/EXIT key to return to running display.

C) TIMER tm2[G] - GATED MODE

Typical Applications:

Punch or Pusher rejecters On the detection of a contaminant after the Delay Time a Punch will knock the package off the production line, to give accurate rejection a pack detector is used to 'gate' the position of the product.

Drop or Lift Flap Reject Mechanisms On the detection of a contaminant after the Delay Time the Reject device will operate, this action causes a gap in the production line and product will fall through this gap, to give accurate rejection a pack detector is used to 'gate' the position of the product.

1) Setting and Adjusting Timer tm2[G] - Gated Mode

Once the Engineer has entered the Engineering pass code the display will show...

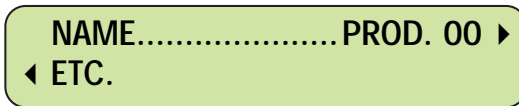

As an example let us say that the reject system is an 'punch or pusher' and the product is a box of Corn Flakes weighing 750g.

Firstly attach the test sample to the Rear / Trailing Edge of the packet and test the Sensitivity to make sure that the test packet causes a detection and that the deflection on the bar-graph is a maximum of Two Red segments, if not re-adjust the Sensitivity to give the deflection as shown below...



Adjust the Sensitivity so that this condition is met, the metal detector timer must only be adjusted to the smallest detectable metal test sample otherwise it may be possible to miss metal contaminants even though they were detected.

Once the Sensitivity has been adjusted, press the ETC soft-key to move down the menu system, until the display shows...

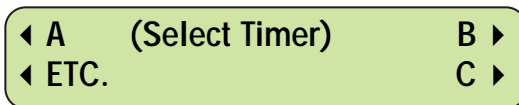

Now select one of the timer locations A, B or C, for this exercise select B by pressing the soft-key next to B. The display may change to show...

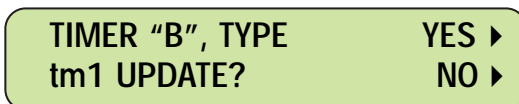

As the object is to adjust this timer the soft-key next to YES is pressed, the display will change to show...

◀ tm1	(Timer	tm2 (G) ▶
◀ ETC.	type)	tm3 (G) ▶

Next select timer type, as we are working with timer tm2[G] press the soft-key next to tm2[G], the display may show...

Gated timer still	YES ▶
required?	NO ▶

If this display is shown press the NO soft-key, the display will change to show...

tm2 SIGNAL DELAY	1.00s ▶
REJECT TIME	1.00s ▶

The previous display shows the Signal Delay Time set value and the Reject Time set value for timer tm2, in this example they are both set to 1 second (1.00s).

Using the prepared test packet of Corn Flakes, pass the pack through the metal detector aperture at the correct speed and orientation with the sample positioned at the rear / trailing edge of the pack, note the operation of the reject device.

The reject device must operate just as the Front Leading Edge of the pack reaches the reject device, from this test it was observed that the reject device operated too early therefore the Signal Delay needs to be increased.

For this example the Signal Delay has to be increased to 3 seconds.

tm2 SIGNAL DELAY	1.00s ▶
REJECT TIME	1.00s ▶

From this display press the soft-key next to SIGNAL DELAY, this will cause the arrow to flip and a cursor will appear under the right hand digit indicating that this value can be adjusted. The display will show...

tm2 SIGNAL DELAY	1.00s ◀
REJECT TIME	1.00s ▶

Next use the Cursor Move Key to position the cursor under the right hand digit, now press the UP arrow key Three times to change the Signal Delay to 3.00s, the display will show...

tm2 SIGNAL DELAY	3.00s ◀
REJECT TIME	1.00s ▶

Use the test pack to make sure that the adjustment made causes the rejecter to operate just before the front leading edge of the packet, if not re-adjust the Signal Delay.

Press the ENTER key to store this new value in memory.

Now the Reject time will be adjusted to a time long enough to reject the package if it was positioned correctly, but not too long as to reject multiple packs. We are not attempting to reject the box at this stage

As an example say that the Reject time was too long at 1.00 second and needs to be reduced to 500ms (500 milli-second = 0.5 second), so the reject time has to be reduced.

Press the soft-key next to REJECT TIME this will cause the arrow to flip over and a cursor will appear under the right hand digit indicating that this figure can be adjusted, the display will show...

```
tm2 SIGNAL DELAY 3.00s ▶
    REJECT TIME  1.00s ◀
```

Using the cursor move key position the cursor under the second digit and using the 'down key' adjust to read 0.50s (500ms).

Press the ENTER key to store this new setting into memory, the display will show...

```
tm2 SIGNAL DELAY 3.00s ▶
    REJECT TIME  0.50s ▶
```

Press the ENTER key again, the display will show...

```
tm2   Gated?   YES ▶
      NO ▶
```

As this section is for the Gated Mode of operation press the soft-key next to YES, the display will show...

```
tm2G SYNC. DELAY 100ms ▶
◀ ETC. Window Time 100ms ▶
```

Important:

- To set the following parameters it must be ensured that the photo-gating device is clear of any obstruction, i.e. no product passing and breaking the beam.
- A metal test sample is not required to set these parameters.
- Always set the WINDOW TIME before the SYNC. DELAY.

Make sure that a sample box is ready for the next stage in the set-up.

From the above display press the soft-key next to Window Time the display will change to show...

```
tm2G SYNC. DELAY 100ms ▶
◀ ETC. Window Time -CAL- ◀
```

The word -CAL- will appear, do not pass the sample box yet as a calibration process is being carried out, after about 5 seconds the display will change to -RUN- as shown below...

tm2G SYNC. DELAY 100ms ▶
◀ ETC. Window Time -RUN- ▶

When the display changes to show -RUN- pass the sample box along the system in the correct orientation typical of the actual line conditions, if it has a slight skew then present it with a skew. The metal detector will automatically set the Window Time as soon as the pack has passed the photo-cell.

Note the window time, now pass the box again by firstly pressing the soft key next to CAL and wait for the word RUN to appear, this is to ensure that the window time is repeatable.

As an example say that the window time calculated was 400ms (milli-seconds) the display will show...

tm2G SYNC. DELAY 100ms ▶
◀ ETC. Window Time 400ms ▶

Next press the soft-key adjacent to SYNC. DELAY, when this is pressed the detect indicator will light and the detection buzzer will sound, the arrow will flip over and a cursor will appear under the Sync. Delay time. Pass the sample box and adjust the SYNC. DELAY time using the cursor move key and the up/down keys until the pack is rejected accurately and consistently. Press the ENTER key to store this new setting in memory.

As an example the Sync. Delay was adjusted to 600ms, the display will now show...

tm2G SYNC. DELAY 600ms ▶
◀ ETC. Window Time 400ms ▶

Press the ETC key to return to the Reject Time section, the display will show...

tm2G SYNC. DELAY 3.00s ▶
◀ ETC. Window Time 0.50s ▶

Press the soft-key next to REJECT TIME this will cause the arrow to flip over and a cursor will appear under the right hand digit indicating that this figure can be adjusted.

Pass the sample box along the system with the contaminant at the front or the rear edge and adjust the Reject time to a value long enough to reject the package accurately but not too long as to hit the next box on the line.

Press the ENTER key twice to store this new setting in memory.

D.) TIMER tm3[G]: Variable Speed with Delay Time, Reject Time and photo-gated Pack Detector.

This reject timer is used for variable speed conveyor applications or for a process where the product can start and stop on demand. Upon detection of a metal contaminant the reject device will not operate until the contaminated product reaches the reject area, at this time the reject device will operate for the period of time controlled by the Reject Time.

The following drawing shows a typical metal detector conveyor system incorporating a pusher reject system, a speed sensor (or tacho) and a pack detector (photo-cell), note that the rejecter is positioned a distance from the metal detector and that 'good product' is between the metal detector and the reject device. The object is to reject the contaminated product and accept the 'good' product.

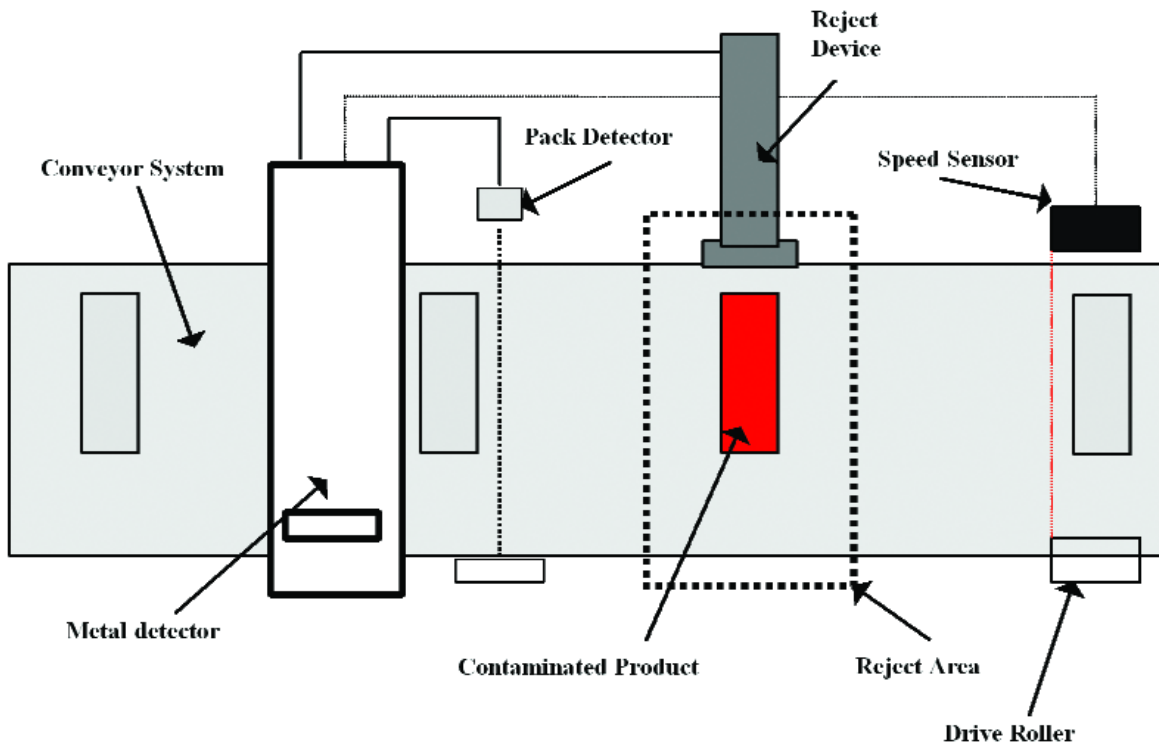

Timer tm3[G] can be used with or without a photo-gated pack detector, the pack detector is used to identify the position of the contaminated package to give pin-point accuracy for rejection.

The timer is used with a speed sensor or encoder, this device is used to generate pulses in relation to the distance travelled by the conveyor belt and hence the product and a possible metal contaminant.

Typical Application

Retracting Band Rejecter: Used when the conveyor is varied in speed or starts and stops on demand of the production process, this can be observed on biscuit dough applications where the product is conveyed to a calendar roller or biscuit press. On the detection of a contaminant after the Delay Time the conveyor belt will retract, this action causes a gap in the production line and product will fall through this gap. This system is used for loose product, i.e. peanuts, chocolates, biscuit dough etc.

Air Blast Rejecters: On the detection of a contaminant after the Delay Time a stream of compressed air will blow the package off the production line.

1) Setting and Adjusting Timer tm3[G] None Gated Mode

Once the Engineer has entered the Engineering pass code the display will show...

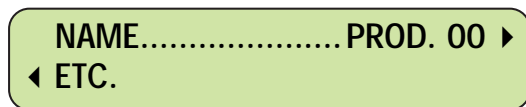

Example: Let us say that the reject system is a retracting band/belt and the product is Biscuit Dough.

Important Note: Set the speed of the system to its MID RANGE point

Now place the test sample into the product and test the Sensitivity to make sure that the test sample causes a detection and that the deflection on the bar-graph is a maximum of Two Red segments, if not re-adjust the Sensitivity to give the deflection as shown below...



Adjust the Sensitivity so that this condition is met, the metal detector timer must only be adjusted to the smallest detectable metal test sample otherwise it may be possible to miss rejecting metal contaminants even though they were detected.

Once the Sensitivity has been adjusted, press the ETC soft-key to move down the menu system, until the display shows...

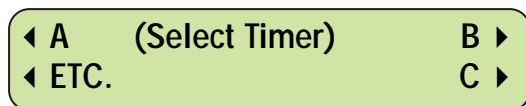

Now select one of the timer locations A, B or C, for this exercise select B by pressing the soft-key next to 'B'. The display may change to show...

TIMER "B", TYPE	YES ▶
tm1 UPDATE?	NO ▶

As the object is to adjust this timer the soft-key next to YES is pressed, the display will change to show...

◀ tm1	(Timer	tm2 (G) ▶
◀ ETC.	type)	tm3 (G) ▶

Next select timer type, as we are working with timer tm3 press the soft-key next to tm3[G], the display may show...

Gated timer still	YES ▶
required?	NO ▶

If this display is shown press the NO soft-key, the display will change to show...

tm1 SIGNAL SHIFT	010 ▶
REJECT SHIFT	010 ▶

This display shows the Signal Shift set value and the Reject Shift set value for timer tm3, in this example they are both set to 10 pulses.

Place the test sample in the product and let it pass through the metal detector aperture at the MID RANGE SPEED of the system, note the operation of the reject device.

The reject device must operate just before the test sample reaches the reject area, from this test it was observed that the reject device operated far too early therefore the Signal Shift needs to be increased.

For this example the Signal Shift has to be increased to 20 pulses (020).

tm3 SIGNAL SHIFT	010 ▶
REJECT SHIFT	010 ▶

From this display press the soft-key next to SIGNAL SHIFT, this will cause the arrow to flip and a cursor will appear under the right hand digit indicating that this value can be adjusted. The display will show...

tm3 SIGNAL SHIFT	01 <u>0</u> ◀
REJECT SHIFT	010 ▶

Next use the Cursor Move Key to position the cursor under the middle digit, now press the UP arrow key once to change the Signal Shift to 020 (20 pulses), the display will show...

tm3	SIGNAL SHIFT	0 <u>2</u> 0 ◀
	REJECT SHIFT	010 ▶

Use the test sample again to make sure that the adjustment made causes the rejecter to operate just before the reject point, if not re-adjust the Signal Shift.

Press the ENTER key to store this new value in memory.

Now the Reject Shift must be adjusted to a time long enough to reject the contaminant, but not too long as to reject too much product.

As an example say that the Reject Shift Time was too long at 10 pulses and needs to be reduced to 5 pulses (005), so the Reject Shift has to be reduced.

Press the soft-key next to REJECT SHIFT this will cause the arrow to flip over and a cursor will appear under the right hand digit indicating that this figure can be adjusted, the display will show...

tm3	SIGNAL SHIFT	020 ▶
	REJECT SHIFT	01 <u>0</u> ◀

Using the 'down key' press 5 times to read 005 (5 pulses).

Pass the metal test sample again and check that the reject device operates at the correct time and for long enough to cleanly reject the contaminant.

Press the ENTER key to store this new setting into memory, the display will show...

tm3	SIGNAL SHIFT	020 ▶
	REJECT SHIFT	005 ▶

Press the ENTER key again, the display will show...

tm2	Gated?	YES ▶
		NO ▶

As this section is for the Non-gated mode of operation press the soft-key next to NO, the display will show...

TIMER "B", TYPE tm3	
set / update	

This display will be shown for approximately 5 seconds after which the user will be returned to the main menu.

Press the PROG/EXIT key to return to the running mode display.

The system should now be tested at the minimum and maximum speeds of the variable speed controller to ensure that the metal test sample is rejected over the full range.

It is highly recommended that upper and lower limits are programmed into the variable speed controller this will prevent the conveyor speed from running at a speed lower than the minimum through-put rate for the metal detector.

E.) TIMER tm3: None Gated Mode

Typical Application

Punch or Pusher rejecters: Used when the conveyor system is varied in speed or the conveyer can be stopped by external equipment. On the detection of a contaminant after the Delay Time a Punch will knock the package off the production line, to give accurate rejection a pack detector is used to 'gate' the position of the product.

Setting and Adjusting Timer tm3[G] - Gated Mode

Important Note: Set the speed of the system to its MID RANGE point

Once the Engineer has entered the Engineering pass code the display will show...

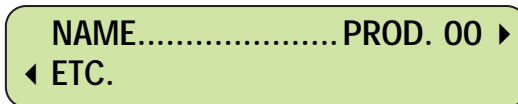

As an example let us say that the reject system is an 'punch or pusher' and the product is a box of Corn Flakes weighing 750g.

Firstly attach the test sample to the Rear / Trailing Edge of the packet and test the Sensitivity to make sure that the test packet causes a detection and that the deflection on the bar-graph is a maximum of Two Red segments, if not re-adjust the Sensitivity to give the deflection as shown below...



Adjust the Sensitivity so that this condition is met, the metal detector timer must only be adjusted to the smallest detectable metal test sample otherwise it may be possible to miss rejecting metal contaminants even though they were detected.

Once the Sensitivity has been adjusted, press the ETC soft-key to move down the menu system, until the display shows...

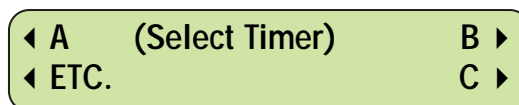

Now select one of the timer locations A, B or C, for this exercise select B by pressing the soft-key next to B. The display may change to show...

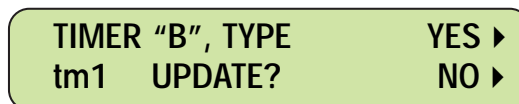

As the object is to adjust this timer the soft-key next to YES is pressed, the display will change to show...

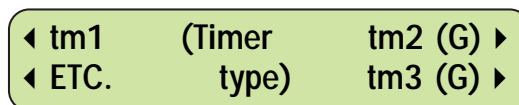

Next select timer type, as we are working with timer tm3[G] press the soft-key next to tm3[G], the display may show...

Gated timer still required?	YES ▶
	NO ▶

If this display is shown press the NO soft-key, the display will change to show...

tm3 SIGNAL SHIFT	010 ▶
REJECT SHIFT	010 ▶

This display shows the Signal Shift set value and the Reject Shift set value for timer tm3, in this example they are both set to 10 pulses.

Pass the test packet, with the sample at the rear trailing edge, through the metal detector aperture at the MID RANGE SPEED of the system, note the operation of the reject device.

The reject device must operate just before the front edge of the test packet reaches the reject device, from this test it was observed that the reject device operated too early therefore the Signal Shift needs to be increased.

For this example the Signal Shift has to be increased to 20 pulses (020)

tm3 SIGNAL SHIFT	010 ▶
REJECT SHIFT	010 ▶

From this display press the soft-key next to SIGNAL SHIFT, this will cause the arrow to flip and a cursor will appear under the right hand digit indicating that this value can be adjusted. The display will show...

tm3 SIGNAL SHIFT	01<u>0</u> ◀
REJECT SHIFT	010 ▶

Next use the Cursor Move Key to position the cursor under the middle digit, now press the UP arrow key once to change the Signal Shift to 020 (20 pulses), the display will show...

tm3 SIGNAL SHIFT	0<u>2</u>0 ◀
REJECT SHIFT	010 ▶

Use the test packet again to make sure that the adjustment made causes the rejecter to operate just before the reject device, if not re-adjust the Signal Shift.

Press the ENTER key to store this new value in memory.

Now adjust the Reject Shift so that the reject mechanism responds in a way that would reject the pack if it was positioned correctly. We are not attempting to reject the pack at this stage.

As an example say that the Reject Shift Time was too long at 10 pulses and needs to be reduced to 5 pulses (005), so the Reject Shift has to be reduced.

Press the soft-key next to REJECT SHIFT this will cause the arrow to flip over and a cursor will appear under the right hand digit indicating that this figure can be adjusted, the display will show...

```
tm3 SIGNAL SHIFT 020 ▶
    REJECT SHIFT 010 ◀
```

Using the 'down key' press 5 times to read 005 (5 pulses).

Pass the test packet again and check that the reject device operates at the correct time and for long enough.

Press the ENTER key to store this new setting into memory, the display will show...

```
tm3 SIGNAL SHIFT 020 ▶
    REJECT SHIFT 005 ▶
```

Press the ENTER key again, the display will show...

```
tm3 Gated? YES ▶
    NO ▶
```

Press YES for Gated mode of operation, the display will show...

```
tm3G SYNC. SHIFT 100 ▶
◀ ETC. Window Shift 100 ▶
```

Important:

- To set the following parameters it must be ensured that the photo-gating device is clear of any obstruction, i.e. no product passing and breaking the beam.
- A metal test sample is not required to set these parameters.
- Always set the WINDOW SHIFT before the SYNC. SHIFT.

Make sure that a sample box is ready for the next stage in the set-up.

From the above display press the soft-key next to Window Shift the display will change to show...

```
tm3G SYNC. SHIFT 100 ▶
◀ ETC. Window Shift -CAL- ◀
```

The word -CAL- will appear, do not pass the sample box yet a calibration process is being carried out, after about 5 seconds the display will change to -RUN- as shown below...

```
tm3G SYNC. SHIFT 100 ▶
◀ ETC. Window Shift -RUN- ◀
```

When the display changes to show -RUN- pass the sample box along the system in the correct orientation typical of the actual line conditions, if it has a slight skew then present it with a skew. The metal detector will automatically set the Window Shift as soon as the pack has passed the photo-cell.

Note the window shift, now pass the box again by firstly pressing the soft key next to CAL and wait for the word RUN to appear, this is to ensure that the window shift is repeatable.

As an example say that the window shift calculated was 008 pulses the display will show...

tm3G SYNC. SHIFT	300 ▶
◀ ETC. Window Shift	008 ▶

Next press the soft-key adjacent to SYNC. SHIFT, when this is pressed the detect indicator will light and the detection buzzer will sound, the arrow will flip over and a cursor will appear under the Sync. Shift time.

Pass the sample box and adjust the SYNC. SHIFT time using the cursor move key and the up/down keys until the pack is rejected accurately and consistently. Press the ENTER key to store this new setting in memory.

As an example the Sync. Shift was adjusted to 030, the display will now show...

tm3G SYNC. SHIFT	030 ▶
◀ ETC. Window Shift	008 ▶

Press the ETC key and note that the Reject Shift has changed to Reject Time, the display will show...

tm3G SIGNAL SHIFT	020 ▶
◀ ETC. Reject Time	050ms ▶

Press the soft-key next to REJECT TIME this will cause the arrow to flip over and a cursor will appear under the right hand digit indicating that this figure can be adjusted.

Pass the sample box along the system with the contaminant at the front or the rear edge and adjust the Reject time to a value long enough to reject the package accurately but not too long as to hit the next box on the line.

Press the ENTER key twice to store this new setting in memory. The user will be returned to the running mode display

The system should now be tested at the minimum and maximum speeds of the variable speed controller to ensure that the metal test sample is rejected over the full range.

It is highly recommended that upper and lower limits are programmed into the variable speed controller this will prevent the conveyor speed from running at a speed lower than the minimum through-put rate for the metal detector.

4.15: INVERSE DETECTION

Inverse detection is used to detect the presence of a metallic premium or free gift within a product package or box. The metal detector will detect the premium, if the premium is not detected then the reject device will operate rejecting packs that do not contain the free gift.

The metal detector operates in the normal manner but the action of the reject device is reversed - metal is accepted, absence of metal is rejected.

Operation of Inverse Detection: Inverse detection is set-up in the usual manner, the factors to be aware of are:

1. The metallic free gift or insert must be set in a position that allows the metal detector to just detect it when in the worst orientation for detection. The reject timer is adjusted to this condition.
2. The FAST RECOVERY electronic module must be used.
3. There must be a sufficient gap between consecutive products as to allow the metal detector to recover after detection of the metallic insert, otherwise a product with the insert missing could be accepted incorrectly.

The inverse detect option is selected once the above steps have been carried out, as follows...

Selecting Inverse Detection: Note: Inverse detection can only be used when using a photo-gated timer tm2[G] or tm3[G] as the packet must be photo-gated.

Inverse detection is an option and it is factory set by Safeline when specified by the customer, when selected it can be switched on or off in the Engineering mode.

Access the Engineering mode using the Engineering pass code, when the code has been entered the display will show...

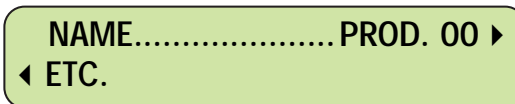

From this display press the ETC key until Inverse detection is displayed as shown below...

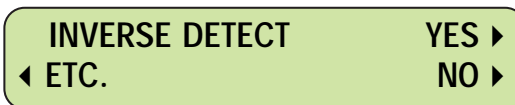

To select the function in the chosen product number press the soft key next to the YES arrow, this will flash the letter 'Y' informing that selection has been successful.

Press the PROG/EXIT key to exit and return to the running mode display.

4.16: PRODUCT SIGNAL CANCELLATION (P.S.C.)

Reduction of a product effect signal by adjustment of the 'phase' control either manually or automatically very often does not eliminate the product signal completely. Due to this effect the sensitivity is sometimes reduced which in turn leads to reduced performance.

Product Signal Cancellation (P.S.C. or Product Cancellation) aims to eliminate any remaining Product Effect Signal without the need to operate at a reduced sensitivity.

System Requirements:

- The conveyor must run at a fixed speed, minimum speed 10 m/min.
- A pack detect photocell must be fitted before and as close to the metal detector as possible.

Product Requirements:

- The maximum pack length must not exceed 1 meter.
- The product effect signal must be consistent and repeatable.
- The minimum space between packs must be 25mm.
- Product presentation must be consistent, product guides may be necessary.
- Up to 5 correctly presented products may be in the aperture at any one time.

If any of the above requirements cannot be met, please consult with a Safeline representative.

Selection of Product Cancellation: Note: Product cancellation can only be used in conjunction with a photo gated pack detector. Product cancellation is available in products numbered 01 to 05 only.

Product cancellation is an option and is factory set by Safeline when specified by a customer order, when selected it can be switched on or off in the engineering mode.

To select P.S.C., access the engineering mode using the engineering pass code, when the code has been entered correctly the display will show...

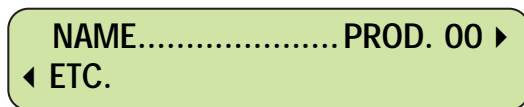

From this display repeatedly press the ETC soft key until Prod. Cancellation is displayed, as shown below...

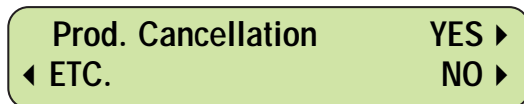

Press the YES soft key to turn on the function; this will cause the Y to flash indicating that the selection has been successful.

Press the PROG/EXIT key to return to the running mode display.

Now that P.S.C. has been activated if an improvement can be made in sensitivity on completion of the automatic set-up routine, the following directions will be given to the operator.

After the automatic product adjustment the display will show...

Product cancellation	YES ▶
	NO ▶

If this display is not shown it will mean that an improvement cannot be made using P.S.C.
Press the soft key next to YES to continue with product cancellation, the display will show...

**PASS PRODUCT THROUGH
APERTURE...**

Pass the product package through the metal detector, the display will show...

**OBTAINING PRODUCT
INFORMATION 1...**

Followed by...

PLEASE WAIT...

Followed by...

**PASS PRODUCT THROUGH
APERTURE...**

Pass the product package through the metal detector again, the display will show...

**OBTAINING PRODUCT
INFORMATION 2...**

Followed by...

PLEASE WAIT...

Followed by...

**PASS PRODUCT THROUGH
APERTURE...**

Pass the product package through the metal detector again, the display will show...

ADJUSTING SENSITIVITY...

Followed by...

PRODUCT ADJUSTMENT COMPLETED...

If an error has occurred or the PROG/EXIT key was pressed the following display will be shown...

PRODUCT CANCELLATION NOT OPERATING...

Now the adjustment is complete, the letter 'P' in the word PHASE will flash indicating that P.S.C, is working.

◀ SENS. 190	PROD. No.01 ▶
◀ ETC.	PHASE 0000 ▶

The letter 'P' will flash.

Note: Manual adjustment cannot be made once PSC is in operation, if a change is made to the phase setting the PSC option will turn off and stop operating.

4.17: REJECT CONFIRMATION

Reject confirmation is used to detect that the reject device has operated and rejected a contaminated product.

When the metal detector has detected a metal contaminant a signal is sent to the Reject confirmation unit, this unit starts a timer, and this timer is reset by the action of either the reject mechanism operating or a package being rejected. If the timer is not reset then an alarm signal is given, this signal can be used to sound an alarm or shut the production line down.

Shown below is a representation of a metal detector and a reject device indicating the position of both mechanical movement sensors and physical rejection sensors?

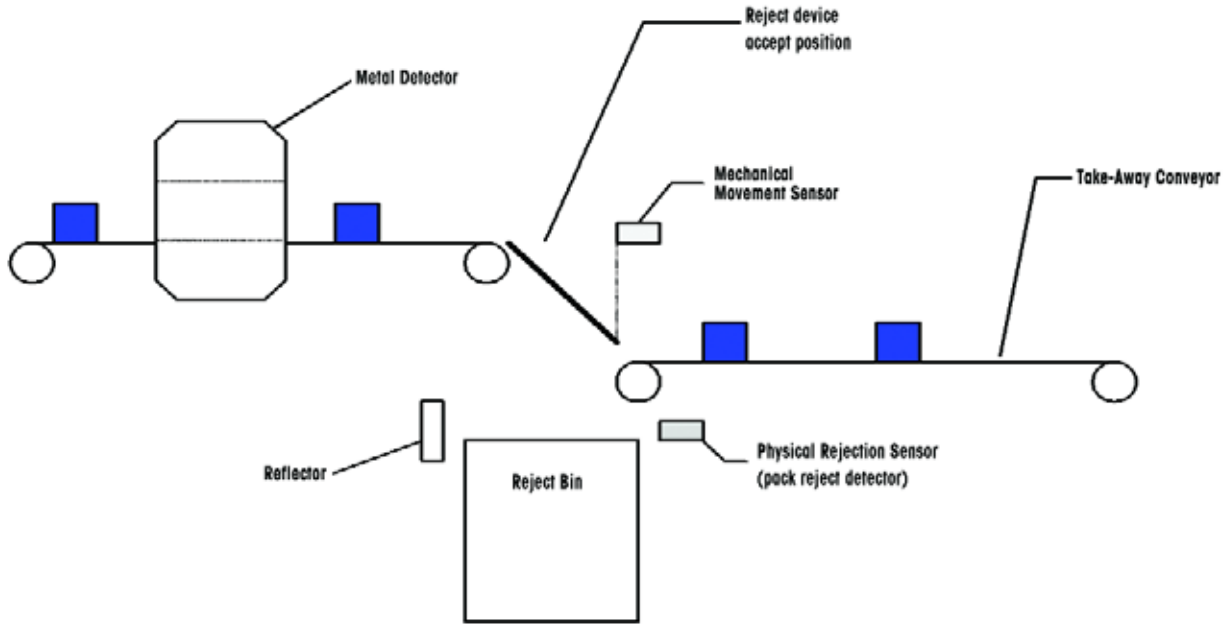

Only one sensor is used to reset the reject confirmation unit, the above drawing is indicating were the sensors would be fitted in an actual application.

Setting up Reject Confirmation: Firstly a reject confirmation unit (RCU) must be fitted to the power supply board and a second relay fitted / plugged in location RL2, a detection sensor must be wired and secured in position.

Reject confirmation is controlled from the engineering mode. First enter the engineering pass code, when entered correctly the display will show...

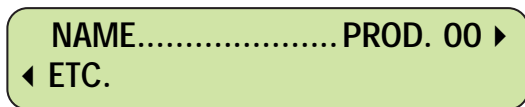

Using the ETC soft key move along until 'Reject Confirm' is displayed as shown below...

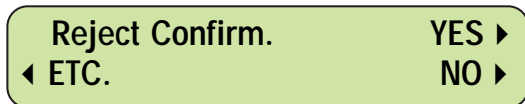

Press the soft key next to YES to select the function, the letter 'Y' will flash to indicate that the selection has been made.

Press the ETC key to move forward.

There are two possible displays which are dependent on the timer type being used, these are:

1. Extension Time - used with timer types tm1, tm2 and tm2(G)
2. Window Time - used with timer types tm3 and tm3(G)

1. **Extension Time:** If Extension Time is used the display will show:

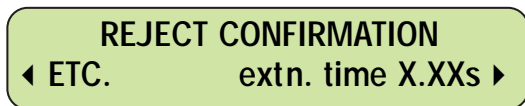

The 'extension time' is the time taken for the external sensor to detect that a contaminated package has been rejected. If the sensor does not detect the contaminated pack with-in the extension time then a fault will be given.

The 'extension time' begins after the reject system has operated.

To set the extension time press the soft key next to seconds (s) this will allow the time to be adjusted or set.

2. **Window Time:** If window time is used the display will show...

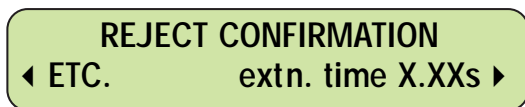

The 'window time' is the time from when the metal detector detects a contaminant to a time after the sensor has detected and rejected the contaminant.

To set the window time presses the soft key next to seconds (s).

Note:

1. Reject confirmation cannot be used on start / stop applications
2. The window time must be set with the conveyor running at its slowest speed to ensure proper operation over the rest of its variable speed range.

Setting and Testing the Reject Confirmation Unit (RCU): The RCU is fitted with two indicators - a red FAULT indicator and a yellow LED, these indicators are used to aid the setting up procedure.

When using extension time set the time to 100 milli-seconds (ms), pass the metal test sample either fixed to a package or in the product if not using packaged product. The yellow LED will light just before the reject device operates and should stay lit until the reject device returns to its normal accept position and the contaminated product has been rejected. If the yellow LED turns off before this action the red FAULT indicator will light and a fault will be given. If this happens reset the RCU using the reset switch and adjust the extension time in steps of 100ms until the above condition is met, then increase a further 200ms. The ENTER key is then pressed to store this new setting into memory.

Diagram of the RCU

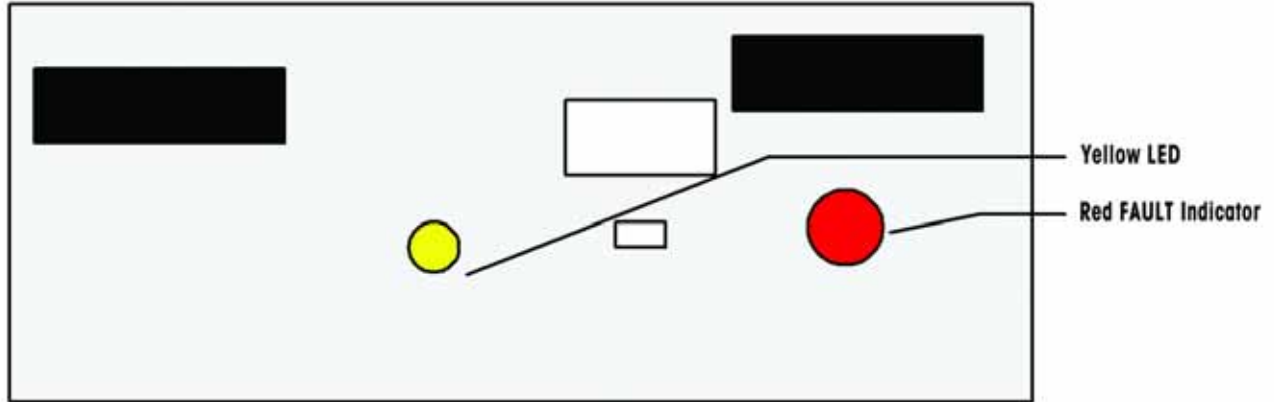

When using window time estimate the time taken for the contaminated product to travel from the centre of the metal detector aperture and enter the reject bin. Set the window time to this estimated value.

Pass a metal test sample through the metal detector aperture making sure the detector triggers.

The Yellow LED will light immediately and at the programmed time the reject device will operate from its accept position to its reject position.

When the reject mechanism returns to its accept position the reject sensor will detect that the reject system has operated and the Yellow LED will turn off **providing that the 'window time' is long enough**. If the Red fault indicator lights re-set the RCU using the reset switch and re-adjust the 'window time' by a further 500ms. Repeat this exercise until the red indicator remains off, then reduce in steps of 100ms until the red indicator turns on, this is to find the 'switch over' point. When this point has been found increase the window time by 300ms and press the ENTER key to store this new value into memory.

Fault Messages: If the reject confirmation unit is not reset by the operation of the sensor then an alarm will be given and a message will be displayed as shown below...

**Reject Confirmation
REJECT FAULT**

The alarm output can be used to stop the production line or just give an audible / visual alarm, connections are made to relay RL2 on the power supply board.

This display will clear when the RCU is reset and the fault is cleared, an external reset switch is fitted to terminals on the power supply board.

If the metal detector cannot communicate with the RCU the following message will be shown...

**REJECT CONFIRMATION
input / Output FAULT**

This display will clear when the fault has been cured.

4.18: QA INSPECTOR MODE AND PERFORMANCE VALIDATION ROUTINE (P.V.R)

The module will discuss the operation of the QA Inspector Mode, it will also demonstrate the use of the Product Validation Routine.

The Q.A. Inspector mode is part of the Product Validation Routine as the inspector sets the performance parameters for P.V.R.

P.V.R. helps the user comply with ISO 9000 by ensuring that the metal detector system is tested and operating to the users specified quality standards of performance.

The quality standards of many users require that the metal detector and its reject system is tested at specified intervals by authorized Q.A. personnel to validate compliance.

Q.A. personnel may program the metal detector to indicate when testing is required and to give an alarm if the test is not carried out at the specified time. Individual staff may be given a personal access code ensuring that the individual charged with testing does so at the required time.

The Q.A. Inspector Mode - setting up P.V.R.: To access this mode enter the QA Inspector code, the factory setting is 0004 (this code may be changed in the engineering mode). Once the code has been entered correctly the display will show...



Press QA SET-UP to enter the set-up menu, the display will show...



At this point a line identification number can be entered, for example the first two numbers could be a line number and the other numbers the metal detector number. Press the soft-key next to LINE ID. and enter the number using the cursor move and up / down arrow keys.

Press the ETC key to move on, the display will show...

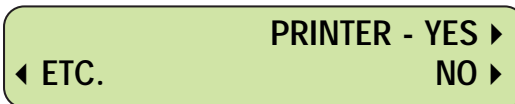

Press YES if a printer is connected to the metal detector, NO should always be selected when a printer is not connected, otherwise a printer connect error may be given.

Press the ETC key to move on, the display will show...

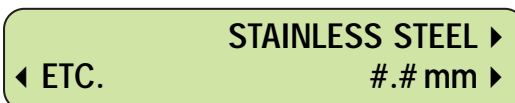

This display allows a test sample size to be entered which will be prompted for during the performance check. There are three independent settings for each of the 21 product numbers. Press the soft key next to the material the display will show...



and again to show....

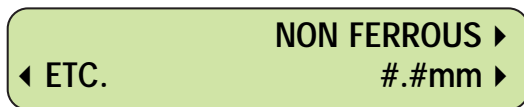

To set the sample size press the soft-key next to 'mm' this will cause the arrow to flip over and a cursor will appear under one of the digits as shown below...

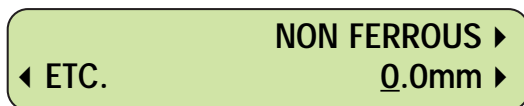

Enter the sample size value using the up/down keys in conjunction with the cursor move key, when the value is entered press the memory key. Carry out this procedure for each of the materials - stainless steel, ferrous and non ferrous.

Press the ETC soft-key to move on, the display will show...



Press SHIFT REPORT OPTIONS soft-key to access this section, the display will show...

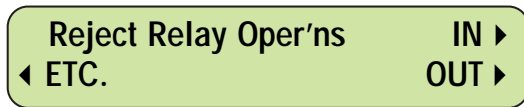

This section will allow the number of reject relay operations to be included on the print out.

IN means the report will include the date and time of each relay operation.

OUT means the report will not include this information.

Press the required soft-key either IN or OUT, a cursor will flash on the option made.

Press the ETC to move forward, the display will show...

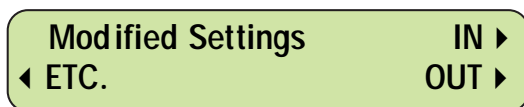

This section will allow the printed report to show when a setting was changed.

IN - this will include certain settings which have been changed since the last shift report. The shift report will include the settings new value and the date and time when it was changed.

The settings which are recorded are:

- Product Number
- Sensitivity
- Phase
- Timer Type
- Reference Phase
- Pack and Reject counter resets
- Reject Inhibit

OUT - the function is turned off.

Press the ETC to move forward, the display will show...

Shift report Int. H. xx ▶
 ◀ ETC. M. xx ▶

The shift report can be printed automatically on a timed basis specified by the user. A time is entered using the H (hours) and M (minutes) soft keys.

H = hours, can be adjusted to a maximum of 8

M = minutes, can be adjusted to a maximum of 59

This will allow a maximum of 8h:59m between shift reports, setting the time to 0.00 disables this function.

Press the enter key to move forward the display will show...

Shift report start H. xx ▶
 ◀ ETC. M. xx ▶

This will allow the start time of the shift report to be set to a specified time.

H = hours, can be adjusted to a maximum of 23

M = minutes, can be adjusted to a maximum of 59

Press the ETC key to move forward, the display will show...

Test interval - H. x ▶
 ◀ ETC. M. xx ▶

The test interval is the time period between which the metal detector system requests the QA personnel to carry out a performance check. The following message will appear when the test is due...

***REQUEST FOR
 PERFORMANCE CHECK***

The test interval time is restarted when a performance check has been carried out.

H = hours, can be adjusted to a maximum of 8

M = minutes, can be adjusted to a maximum of 59

This will allow a maximum of 8h : 59m between performance checks, setting the time to 0.00 disables this function.

Press the ETC key to move forward, the display will show...

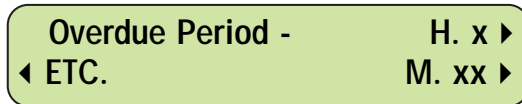

This section is used to set an alarm indicating to the operator that the metal detector is overdue for the performance test. If this time is reached the display will change from...

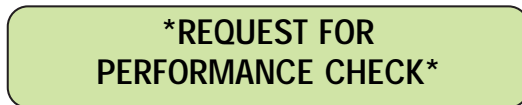

to...

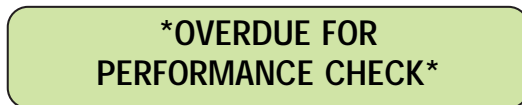

The Bar-graph will flash and the buzzer will sound to attract attention, an output alarm signal is also available, (see next section).

The maximum overdue period is restricted to half of the test interval time.

Press the ETC key to move forward, the display will show...



The Alarm can be selected for either Due or Overdue conditions.

DUE - means that the alarm is given when the performance test is due.

OVERDUE - means that the alarm is given when the performance test is overdue.

Select the required condition from this section.

Press the ETC key to move forward, the display will show...

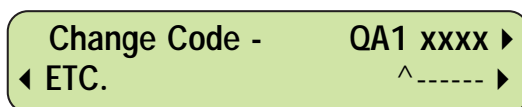

This section allows the QA operator code to be changed, there are nine QA operator codes.

To change the required code press the soft key adjacent to ' ^----- ' until the number is displayed (i.e. 1-9), then press the soft key next to the four digit code number - this will cause the arrow to flip over and a cursor will appear under the first digit. Enter the required code then press the ENTER key to store the new code into memory.

Example the new operator is 7 and the code is 5702, the display will show...

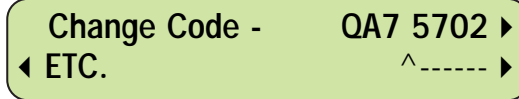

Change Code - QA7 5702 ▶
◀ ETC. ^----- ▶

Press the ETC key to return to menu, the display will show...



◀ QA SETUP TEST ▶
◀ ETC.

Carrying out Performance Validation

A performance check may be carried out at any time, the PVR may have been configured to automatically prompt the user (normally authorized QA personnel) to carry out a performance check. This will occur at regular intervals determined by the pre-programmed test interval.

The next test time can be checked by pressing the ETC key twice from the normal running display, when this is done the display will show...

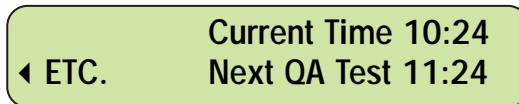

◀ ETC. Current Time 10:24
Next QA Test 11:24

Note.: If PVR has been set for timed checks the test interval time will be restarted after the check has been carried out.

Carrying out a test: A metal test sample is required either placed in the product or secured to a sample package. When passing the test sample try to keep the sample as close to the centre of the metal detector aperture as possible.

Firstly enter either a QA Inspector code or a QA operator code, if the inspector code is entered the display will show...



From this display press the TEST soft key, the display will show...

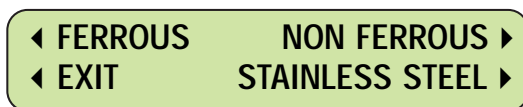

Press the required material, in this example FERROUS will be tested, press the soft key next to FERROUS the display will change to show...

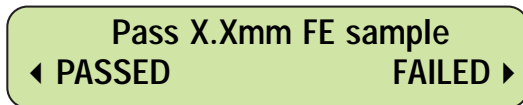

This display will show the size of test sample to use, if using packaged product attach the sample to the pack and allow it to pass through the detector on the conveyor belt. Ensure that the test sample is detected (and rejected if a reject device is fitted).

Enter the result of the test by pressing the PASSED or FAILED soft key, the display will return to the menu as shown below.

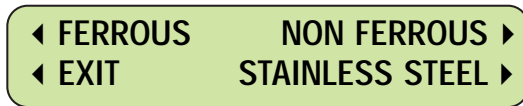

If other materials are to be tested press the appropriate soft key and pass the test sample associated with that material.

If the performance check has been completed press the 'EXIT' soft or the 'PROG/EXIT key.

If a printer is connected, the test result will be printed and produce a hard copy as evidence of completion of the test.

Print-Outs / Data Collection: The following assumes that a printer is connected and that the printer option has been selected in the QA inspector set-up, as shown below...



Once the printer has been selected the metal detector PRINT option can be used, from the following display accessed from the QA inspector pass code the print soft key can be pressed.



When the PRINT key has been pressed the display will change to show...

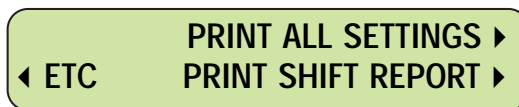

PRINT ALL SETTINGS will cause the printer to print out all the current settings held within the metal detector headed with the sub-heading ****SETTINGS****

PRINT SHIFT REPORT will cause the printer to print out all the current Shift report information which has compiled from the last shift report print-out, it will be headed by the sub-heading ****SHIFT REPORT START****

TROUBLESHOOTING

5.1 Introduction

This section is dedicated to assisting the technician in providing a step-by-step method to resolve the most common service issues. Also included are the detector circuit fault and warning messages.

5.2 Low Sensitivity

In the event of a failed validation test, ensure the detector is still properly set-up. This should include not only the current product set-up, but also all of the factory parameters.

A. Maximum Sensitivity Testing

If the detector is suspect of having lost sensitivity, the following test will assist to confirm factory specification. It will require the original ferrous test samples supplied with the system.

1. Stop product flow
2. Stop conveyor (if applicable).
3. Ensure no product is in the detectors aperture.
4. Enter the engineer's mode
5. Set the product number to (00)
6. Set the sensitivity to (199)
7. If the system is a conveyor, select a non-metallic package. Ensure no metal contamination is present in the package.
8. Select the smallest ferrous sample that was originally supplied with the system. Locate the sample on the rear edge of the empty test package in the direct center of the detectors aperture.
9. Turn the conveyor "on" and pass the test package so the metal sample passes through the center of the detector aperture.
10. A detection must occur with this sample. Repeat multiple times to ensure detection.
11. If the detector does not see the sample, re-check the factory parameters for the power drive and reference phase. If all parameters are set correctly, substitute another Control Module and inspect all module cabling. Repeat the test procedure to confirm proper operation.
12. If after module replacement, unit still does not detect sample, a hardware fault may exist in the detector system and will need returned to Safeline for repair.
(Call Safeline Technical Support for a Return Authorization Number).

5.3 Random Detection

A. Definition

The metal detector registers a detection with AND without product regardless of contamination.

CAUTION: DISCONNECT AIR OR POWER FROM REJECT DEVICE TO AVOID INJURY FROM REJECT OPERATION DURING TROUBLE-SHOOTING.

B. Testing Procedure

1. Set the metal detector to Product number to 00 and Sensitivity to 199.
2. If the system stabilizes, the possible causes of the random detections are:
 - I. Product Effect: The detector may be sensing the product or the product's package.
 - II. Electromagnetic Loop: Metal contact points on the support frame may have loosened or come into contact with other metalwork.
 - III. Reference Phase: The reference phase may be out of adjustment.
 - IV. Metal free zone violation: Metal is positioned too close to the detector.
 - V. Contaminated belting: Contamination will trigger at the contamination points.
With the belt moving, mark the belt with tape to identify the trigger points; remove any metal contamination or replace belt.
 - VI. Static Discharge: Usually found on gravity feed systems or high speed conveyor belts.
System needs to be properly earth grounded.
3. If unit continues to random detect then most probable cause are:
 - I. Module malfunction: Replace with spare module and confirm proper operation.
 - II. Radio Frequency Interference (RFI) or Electromagnetic Interference (EMI):
(See Section 7.12 for troubleshooting assistance)
 - III. Detector damage: A component or sub-assembly of the metal detector is damaged.
 - a. Damaged or delaminated liner.
 - b. Water intrusion into system.
 - c. Damaged electronic sub-system. Replace with spare and verify proper operation.
4. If difficulty is experienced isolating the random detection, try the following:
 - I. Remove the detector system from the installation and relocate to a quiet area.
 - II. Repeat the troubleshooting process.
 - III. If the problem follows the detector system, inspect and isolate to fault.
 - IV. If the problem does not follow the detector system, then there is a high probability the problem is in the installation or production environment.
 - V. Contact Safeline Customer Support for assistance.

5.4 Reject Failure

A. Definition

The reject device fails to operate after a metal detection.

CAUTION: DISCONNECT POWER AT MAIN BREAKER BEFORE WORKING ON ANY ELECTRICAL COMPONENTS.

If applicable, refer to wiring schematic that accompany all Safeline manufactured Pipeline and Conveyors. The schematic is located both in the Power Supply enclosure and the information packet provided.

B. Testing Procedure

1. Ensure that the correct timer type is selected for the application.
2. Ensure the air pressure is adequate. Safeline systems are engineered for 80 psi.
3. Check the solenoid operation. Most solenoid have a test button to initialize operation.
4. Check the pneumatics system for damaged air hoses, fittings, etc.
5. Check that RL1 is changing states for each detection.

Note: RL1 may not be the reject relay in some systems. RL2 can be the reject relay. Please refer to the system schematic for details. In some cases RL1 is used as a latching relay for a system alarm i.e. a beacon or audible alarm.

6. Change the Timer Type to TM1. Cause a detection; RL1 should change states immediately.

If RL1 does not change states:

- I. Set TM1 Reject Time to 5 seconds.
- II. Check for a voltage change between terminals 40 & 36 at the detector power supply. A voltage change should occur from 0.6-0.7 VDC to 5 VDC on a detection.
- III. Check the detector cable for damages, loose connections at the power supply, or misalignment of the connector at the Interconnection Board.
- IV. Possible Control Module malfunction. Replace the Control Module with spare.
- V. Retest for the voltage change. If no voltage change then:
- VI. An Interconnection Board failure may exist. Replace the Interconnection Board with spare.

If RL1 changes states:

- I. Check the voltage supplied to the terminals of the reject relay for the correct voltage.
(Please refer to the power supply schematic on inside lid of power supply enclosure).
- II. A jumper is usually between P/S terminals #1 or #5 to the common terminals #8 and / or #11.
(Note: If RL2 is the reject relay then #15 and / or #17).
- III. Check that the voltage is supplied to the reject solenoid during a detection. Inspect the solenoid for proper operation.
 - a. Turn the detector OFF at the power supply.
 - b. Remove the jumper installed between terminals # 20 and # 21 on the power supply.

This is the latch jumper. Once removed and a detection occurs, RL1 latches after changing states. (Not applicable if RL2 is the reject relay).

- IV. Turn the unit on. RL1 will latch during detector self test. If reject does not operate and remain in the reject position then the device is not receiving power from the power supply.
- V. Check wiring for damage.
- VI. Check device for water intrusion, corroded lead connections.
- VIII. Ensure to replace jumper between #20 and #21 after troubleshooting.

5.5 Multiple Rejects

A. Definition

Unit rejects several times after detector registers only one reject.

B. Verification of Electronic Function

1. Stop product flow and remove any remaining product from the detector aperture.
2. Select TM1 timer for detector.
3. Disconnect air from reject device or remove RL1 from the power supply.
4. From the running mode, press the ETC soft key to display Pack Count and Reject Count.
5. Trigger the detector ONCE with hand or small metallic object. The displayed Reject Count should increase by one and only one.

Note: Bi-directional Over-head sweep reject devices require a small "reject time" timer setting than normal. If set too long the device will sweep both direction which looks similar to the Multiple Reject symptom.

If the Multiple Rejecting Continues:

- a. Replace the Control Module spare.
- b. Replace the Interconnection Board with spare.
- c. Replace the power supply with spare.

Passed, but still getting multiple rejects from one detect signal with product.

1. Pack Spacing:
 - a. For a photo-gated reject operation the pack spacing is too small. One reject but the detector is sensing the next package before the rejected package is out of the detector aperture resulting in one or more rejections.
 - b. Increase the belt speed to increase package spacing.
 - c. Reset the reject timers to reflect the new belt speed.

5.6 Continuous Rejects

A. Definition

The reject device operates, one reject after another without product present.

B. Stopping continuous rejects

1. Disconnect air supply to reject device or turn Reject Inhibit in detector programming "ON" (Note: The last five(5) red LED's on the right side of the bar graph display will begin flashing stopping the normal operation of RL1)
2. Pull RL1 from power supply top board. The reject device should deactivate immediately.

C. Finding the cause

1. Perform a Vibration check. (See SECTION 7.9 VIBRATION)
 - a. If the detector passes the Vibration check, then possible cause of the continuous rejecting maybe:
 - I. RL1 relay is allowing a leakage of voltage backward into the DC voltage of power supply. Replace RL1 relay with spare.
 - II. A power surge is returning from the reject device. Install a surge suppressing capacitor across the terminals at power supply.
2. If the detector fails Vibration check:
 - a. Possible electromagnetic loop in installation or supporting structure (See SECTION 7.10 ELECTROMAGNETIC LOOPS).
 - b. Possible Interference (See SECTION 7.12 INTERFERENCE).
 - c. Possible damaged or delaminated liner (See SECTION 7.3 RANDOM DETECTION).

5.7 Voltage / Power Faults

A. Definition

Unit fails to power up or is missing one or more system voltages

CAUTION: THE FOLLOWING TEST REQUIRES THE POWER TO BE SUPPLIED AS NORMAL TO THE DETECTOR. SEVERE INJURY CAN OCCUR IF CARE IS NOT TAKEN WHEN WORKING ON LIVE ELECTRICAL COMPONENTS.

The detector requires (3) DC Voltages to function during normal operation. The three voltages can be observed from the front of the Control Module to indicate when all power requirements are met.

1. The left most LED signifies the +15 VDC is supplied.
2. The second LED from the left signifies the -15 VDC is supplied.
3. The liquid crystal display, when lit, signifies the +5 VDC is supplied.

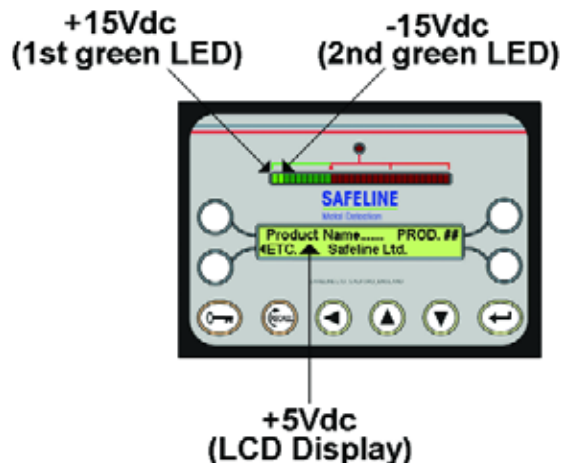

B. Voltage Failure

One or more of the LED's not illuminated when power is switched "ON."

1. Check the AC voltage supplied at the power supply terminals 1 & 2.
2. Check voltage between terminals 43 & 44 = +15 VDC.
3. Check voltage between terminals 42 & 43 = -15 VDC.
4. Check voltage between terminals 41 & 43 = +5 VDC.

(Note: The +5VDC is fused at the power supply top board).

C. Testing for Fault

1. Switch power OFF at power supply.
2. Disconnect the terminal strip numbered 29 through 44 from the power supply. It is not necessary to disconnect the individual conductors from the terminal block.
3. Re-test for the terminal voltages as in steps 2, 3, and 4 above. (Use caution to ensure not to touch the test probes together).
4. If terminal voltages are low or missing then, replace the power supply with spare.
5. If the voltages appear normal, then proceed to inspect the detector head cable for a short or open. Look for any cuts or pinched areas that have damaged the conductors inside cable.
6. Inspect for a possible connector problem with the cable connector below the Interconnect board inside the module cavity. This is usually caused by pulling on the detector head cable below the detector body.
7. Loose or miss aligned module connectors.
8. Replace the Interconnection Board.
9. Replace the Control Module with spare.

5.8 CIRCUIT FAULTS and WARNING MESSAGES

Message type	FAULT
Reason	Essential detector operation is jeopardized
Fault output	Active
Screen status	Message permanently displayed
Detection relay	Active
Bar graph status	Flashing
Audio indicator	Series of short pulses

Message type	WARNING
Reason	Non-Essential detector features affected
Fault output	Active
Screen status	Message intermittently displayed
Detection relay	Inactive
Bar graph status	Normal
Audio indicator	No audible alarm

Message type	CAUTION
Reason	Indicates cautionary message regarding an operation process
Fault output	Inactive
Screen status	Message briefly displayed
Detection relay	Inactive
Bar graph status	Normal
Audio indicator	No audible alarm

2. Identification

The chart below identifies the Circuit Fault and Warning messages for both Version 1 and Version 2 systems (STD), and Powerphase systems (PPH)

STD	PPH	Description	Remedy#
Warning 1	Fault 01	Blank Eeprom	E-1
Warning 2	Fault 02	Blank Eeprom And Blank Ram	E-2
Warning 3	N/A	Partial Ram Default	E-3
Warning 4	Fault 03	Blank Ram	E-4
N/A	Fault 05	One Of The Selectable Values Is Outside Acceptable Limits	E-5
N/A	Warning 07	Communications Fault	E-6
Circuit Fault	N/A	Cpu Fault (Rom. 1.21)	E-7
Circuit Fault 2	Fault 08	Low Level Power Drive Voltage	E-8
Circuit Fault 3	Fault 09	Low Or Missing D.C. Reference Voltage	E-9
Circuit Fault 4	Warning 02	Faulty Eeprom	E-10
Circuit Fault 5	Warning 03	Eeprom Read / Write Error	E-11
Circuit Fault 6	Automatic Setup	Detector Unable To Complete	E-12
	Failed	An Auto-Setup Routine	
N/A	Fault 11 ~ 16	Communications Fault	E-13
Balance Fault	Balance Fault	Detector Coils Out Of Balance	E-14
Bad Rom Checksum Found	Eeprom Checksum Fault	Operating Software (Firmware) Fault	E-15
Data Collection Unit Not Ready	Data Collection Unit Not Ready	Request To Print Without Printer Configured Or Hardware Connected	E-16
Data Collection Unit Not Configured	Data Collection Unit Not Configured	Request To Print Initiated, But Not Selected In The Qa Setup Mode	E-17
Reject Confirmation Reject Fault	Reject Confirmation Reject Error	Reject Device Failed Or Reject Confirmation Circuit Failed	E-18
Reject Confirmation Input / Output Fault	Reject Confirmation Input / Output Error	Firmware Can'T Locate The Hardware Or System Power Turned Off And On Rapidly	E-19

Remedy#	Suggested Troubleshooting Sequence
E-1	<ol style="list-style-type: none"> 1. Press any key to clear the first message. 2. A "Maintain Module Settings" message will appear in the display screen: 3. Press "YES" to download module memory into interconnect eeprom. 4. Press "NO" to default both memories (will require re-programming).
E-2	<ol style="list-style-type: none"> 1. Press any key to clear message. 2. Default settings will be automatically loaded (will require re-programming).
E-3	<ol style="list-style-type: none"> 1. Press any key to clear message. 2. Confirm both factory and user settings for any corrupted data.
E-4	<ol style="list-style-type: none"> 1. Press any key to upload interconnect eeprom memory to module. 2. If message returns after a power down, the modules back-up battery may need replaced, or the modules RAM memory is bad. 3. Replace module if necessary.
E-5	<ol style="list-style-type: none"> 1. Press any key to clear message. 2. Confirm both factory and user settings for any corrupted data. 3. Replace Interconnection board. 4. Replace Module.
E-6	<ol style="list-style-type: none"> 1. Replace Module.
E-7	<ol style="list-style-type: none"> 1. Replace Module.
E-8	<ol style="list-style-type: none"> 1. Ensure detector head and module are the same frequency (or frequency group). 2. Ensure frequency group is selected correctly (PPH system only). 3. Ensure the power drive cable is connected and not damaged. 4. Inspect frequency switching cable for connection or damage (PPH system only). 5. On remote systems, inspect remote cables for connection or damage. 6. Replace Module. 7. Replace Interconnection board. 8. Replace Power Supply.
E-9	<ol style="list-style-type: none"> 1. If missing first or second green bar on bar graph display, proceed to Section C. 2. Inspect for cable connections or damage. 3. Replace Module. 4. Replace Power Supply. 5. Replace Interconnection board.
E-10	<ol style="list-style-type: none"> 1. Inspect flat grey ribbon cable from Interconnection board to Module for connection or damage. 2. Replace Interconnection board. 3. Replace Module.
E-11	<ol style="list-style-type: none"> 1. Inspect flat grey ribbon cable from Interconnection board to Module for connection or damage. 2. Replace Interconnection board. 3. Replace Module.

Remedy#	Suggested Troubleshooting Sequence
E-12	<ol style="list-style-type: none"> 1. Re-run the auto set-up routine and ensure to follow closely. 2. Switch Power Drive to "LOW" and re-try auto set-up (PPH system only). 3. Ensure the conveyor has no contamination in the belting. 4. Ensure there is no metal free zone violations. 5. Ensure there are no electromagnetic ground loops. 6. Replace Module. 7. Replace Interconnection board.
E-13	<ol style="list-style-type: none"> 1. Replace Module.
E-14	<ol style="list-style-type: none"> 1. Ensure there is no product built-up in detectors aperture. 2. Ensure there is no metal free zone violation. 3. On remote systems, inspect the remote head cables for connection or damage. 4. Power down detector. 5. Remove the (4) 13mm bolts that secure the Module to the head or enclosure. 6. Unplug the 6 pin in-line connector from the right hand side of the Module. 7. Power system up. 8. Observe Module display, if message remains, replace Module. 9. If message is absent, detector will require re-balancing (Contact Safeline).
E-15	<ol style="list-style-type: none"> 1. Replace Module.
E-16	<ol style="list-style-type: none"> 1. Ensure printer is connected and powered "ON". 2. Ensure proper handshaking is selected (see Engineering level menu). 3. Inspect printer port and internal cable harness for connection or damage.
E-17	<ol style="list-style-type: none"> 1. Ensure printer is enabled in Q.A. Level menu. 2. Ensure correct selection of "FIXED" or "PORTABLE" in the Q.A. Level menu. 3. Replace Module.
E-18	<ol style="list-style-type: none"> 1. Ensure air pressure is still being maintained to system. 2. Ensure sensor is still operational (signal at power supply terminal #45 and #46). 3. Verify correct reject time (selectable in the Engineers Level menu). 4. Verify correct RCU extension time (selectable in the Engineers Level menu). 5. Ensure the jumper on the RCU board is set for correct polarity (NPN or PNP). 6. Ensure the two position slide switch on the RCU board is set correctly. 7. Replace the RCU board. 8. Replace the Module 9. Replace the Interconnection board.
E-19	<ol style="list-style-type: none"> 1. Power down the detector for approximately 10 seconds. 2. On power up, if message is still present, a hardware fault may exist. 3. Inspect hardware, sensor, and cables for connection or damage. 4. Replace RCU board. 5. Replace Module. 6. Replace Power Supply. 7. Replace Interconnection board.

5.9 Vibration

Mechanical vibration produces signals that make the metal detector unstable and prone to false detection. Specialized electronic circuits incorporated in the metal detector permit for these signals to be minimized for maximum performance.

The REFERENCE PHASE is a detector machine setting which reduces signals caused by vibration. The reference phase is set at the factory and only needs to be adjusted under specific circumstances. The following procedure verifies that the reference phase setting is correct:

A. Verification of the Reference Phase:

NOTE: Before testing or adjusting the reference phase, ensure that the aperture is free of product, electromagnetic ground loops are broken, and any metal free zone violations are removed.

1. Set the detector to product number "00" and raise the sensitivity to "199".
2. With a soft rubber mallet or heel of hand, induce vibration into the detector by striking lightly at the top and sides of the detector to induce vibration. The induced vibration should mimic normal vibration that occurs during production. Observe the reaction of the detectors bar graph display
 - a. 1-2 green bars = normal and no adjustment to the reference phase is necessary. The Product Phase angle for the product may need to be slightly adjusted.
 - b. 3-5 green bars = OK, if not operating the detector above a sensitivity setting of 180. Adjust the reference phase by the one's digit to fine tune, see below.
 - c. More than 5 green bars or detects = Adjusting Reference Phase required.

B. Adjusting the Reference Phase (Version 1 & 2 Systems Only)

1. Enter the Engineers Mode level.
2. Advance to the screen that reads "Adjust Reference Phase".
3. Press the upper right soft key.

(Note: The screen will read: "See OPERATING MANUAL PRIOR TO ADJUSTMENT!" and automatically advance to the screen where the Reference Phase and the sensitivity setting can be adjusted).

RECORD THIS REFERENCE PHASE NUMBER.

4. Induce vibration as above and observe the bar graph signal. If all the red LED segments light when vibration is induced, lower the sensitivity setting so the vibration does not register more than 10 of the available 20 red LED segments.
5. Begin adjusting the reference phase either up or down until the signal on the bar graph is reduced to a maximum signal level of 0-3 green bars at a sensitivity setting of "199".
6. Press the ENTER key to store the new value.
7. RECORD THE NEW REFERENCE PHASE NUMBER for that detector serial number for future reference.
8. Exit the Engineering mode level and return to the Running Mode display screen

NOTE: On newer Version 2 systems and all Powerphase systems, the Reference Phase must be set using a ferrite wand due to the nature of the solid potting material. Please contact Safeline Customer Service for assistance.

5.10 Electromagnetic Loops

The construction of the metal detector support framework can influence the performance of the detector. A detector mounted on an inadequate support structure will exhibit poor vibration characteristics and be prone to random false triggering.

Even metalwork positioned outside the metal free zone can act as an aerial or receiving antenna, making the entire framework susceptible to electromagnetic loops. The field generates minute electrical currents that flow in the surrounding metalwork.

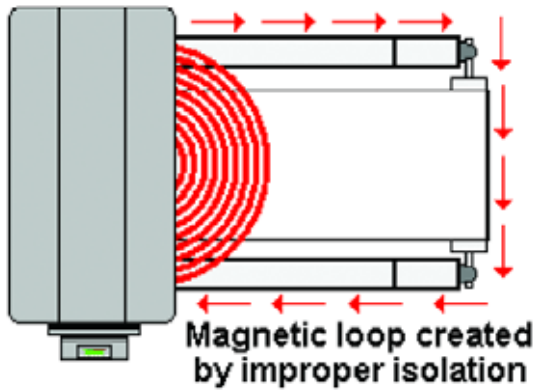
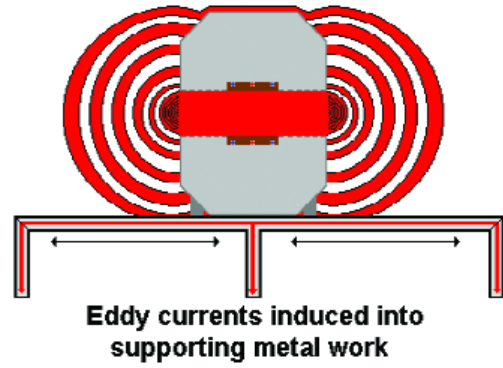

The current flows through the closed path or loop created by the rollers mounted across the conveyor frame. Loops can be avoided by opening or closing the loop in a permanent manner. It is the intermittent nature of a loop path that causes the random triggering of the metal detector.

The problem with the rollers on the conveyor can be overcome by insulating one end of the roller from the conveyor frame. This may take the form of a plastic insulation plate and washers on the bearing mounting block or a plastic bushing at one end of the roller shaft. By insulating the roller in this way the loop is opened

permanently. The support frame should be of welded construction rather than bolted sections. A welded construction is an example of a permanently closed loop. Any metallic items bolted to the conveyor frame, (i.e. guards, conduit, or any metallic objects) potentially create loops. To avoid difficulty insulate/isolate all items bolted to the frame.

5.11 Metal Free Zone (MFZ)

The aperture opening of the detector allows some of the electromagnetic field generated by the transmitter to extend beyond the case. Any external metal must be kept at a distance from this point. This "zone" is referred to as the metal free zone (MFZ) of the detector. A formula can be used to calculate the required distance of the zone and is based on the height of the aperture dimension.

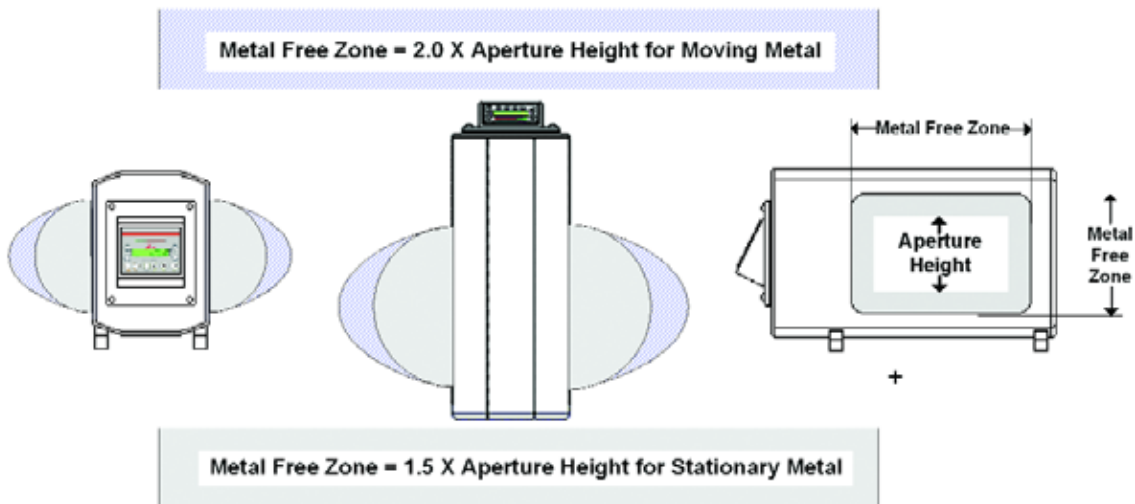

5.12 Interference

A. Source Power

1. The power source for the detector should be fitted with an isolation switch and an appropriate circuit breaker and/or fuse.
2. The mains supply for the detector should be an independent feed.
3. It is recommended that the power source for the detector be taken from a source that supplies only low power equipment.
4. DO NOT power the detector from sources that supply varying current loads such as inverters, switching networks, variable speed drives, or heavy current drawing loads. ALWAYS protect the supply feed to the detector with an approved lightning/surge suppression device.

B. Grounding

1. ALWAYS properly ground the detector systems electrical supply. Use a low impedance cable and ensure solid contact at both ends.
2. A chassis or frame ground may also be required depending on the product application. If a chassis or frame ground is required, a one gauge low impedance cable should be used. Ensure this cable is as short as possible and terminated to a proper grounding/earth rod (See your local code for establishing a proper earthing/grounding rod).

C. Power Filtering

Plant power interconnected through several pieces of equipment can allow load fluctuations that the detector power supply cannot filter out. Line filters, power conditioners, and isolation transformers are the most cost-effective method to eliminate spikes in supplied power.

Verification:

1. Remove the power from the detector power supply and replace with a separate, independent power cord from a known low voltage source or utilize input power from a standard computer UPS system.
2. If the detector operates more effectively, then a dedicated low voltage line feed and /or power filter or line conditioner may be required.

D. Radio Frequency Interference (RFI)

Devices such as variable frequency drives (VFD's), two way radios, citizen band (CB) radios, cellular phones, personal pagers, other metal detectors, etc, emit radio frequencies. These frequencies can interfere with the metal detector and cause false triggering.

E. Electromagnetic Interference (EMI)

The metal detector generates an electromagnetic field. It is susceptible to other fields generated by motors, high voltage conduit lines, magnetic separators, audio speakers, and other electromagnetic devices. The solution is to separate such devices from "close" proximity to the detector or provide a grounded shield between the device and detector like a metal plate.

Verification:

1. Turn off any other machinery, especially variable frequency drives, two-way radios, and other metal detectors one at a time.
2. Once the interference source is turned off, the detector will operate normally.
If the equipment is another metal detector, the Control Module will need to have the frequency staggered. Please call Safeline Customer Support for assistance.

F. Shielding

Each component must be grounded to manufacture specifications and all conduit or cable runs must be properly shielded and grounded.

1. Replace any plastic conduit, junction boxes, cable fittings, etc, with metal.
2. All facets of the system must be linked together using low impedance connections to form a continuous unbroken shield.
3. Keep all connections as short as physically possible
4. When possible, avoid routing conduit and cabling in close proximity to the metal detector.
5. Use the largest surface area as a good ground conductor, for example a properly grounded cabinet wall or control panel plate inside a cabinet

G. Variable Frequency Drives (VFD's)

Frequency control devices emit large quantities of RFI into the surrounding area. These frequencies can be minimized with the following screening and adjustment techniques:

1. The cabinet, conduit or cable, and the motor housing must be connected together to form a single screen. No interruptions of the screen are permissible.
2. The inverter drive with its switching elements is the main source of the interference. Mounting the Inverter in a properly shielded and grounded metal enclosure can help to reduce RFI emissions
3. Ensure that the conduit or cabling to the motor is properly grounded. Avoid the usage of unshielded (rubberized) cables. If cable is used as the conductor to the motor, use a braid-shielded cable and ground the shield to the panel where the drive is mounted. The best ground for the braid of the cable is a strap. This strap should fit tight to the braid, and mount to the ground structure, the panel of the drive. Remember to keep the connection as short as possible. Expose the braid shield, fit the strap over the exposed area, and fasten securely.
4. Some VFD's have the capability of changing the carrier frequency of the VFD known as the pulse width modulation (PWM). Read the operations manual for the device in question to determine if this adjustment is possible. If adjusting this carrier frequency is possible, adjust in small increments while watching for a reduction in the bar graph display of the detector. While it may not be possible to completely eliminate the entire interference signal, usually a setting can be found that results in the best performance of the detector.

H. Multiple Interference Sources

In some cases, the operating environment of the detector is where many VFD's or sources are discovered. A methodical process of elimination can help to minimize the interference and restore stability to the metal detector system.

1. Start with the equipment causing the largest signal recognized from the reaction of the detector on the bar graph display (this will often time be the equipment in closest proximity to the metal detector).
2. When the first VFD has been adjusted for the best possible performance, then move to the next source.
3. The first source adjustment may need minor readjustment when working with the second, third, or fourth source.

www.mt.com/safelineus

For more information

Mettler-Toledo Safeline

6005 Benjamin Road, Tampa, FL 33634, USA

Tel: 1-800-447-4439

1-813-889-9500

Fax: 1-813-881-0840

Email: safeline.sales@mt.com

1/08 METTLER-TOLEDO Product Inspection

Printed in US

MAN-01