

# Evaporative Condensers



## Product Detail

Introduction .....	J2
Features .....	J4
Benefits .....	J10
Construction Details.....	J14
Options and Accessories .....	J20
Selection .....	J24
Engineering Data.....	J32
Support .....	J48
Engineering Specifications.....	J50
Engineering Manual.....	J54

# Evaporative Condensers

*BAC offers evaporative condensers in six different styles to suit every industry application.*

## CXV Models -

**CXV** models deliver efficient performance in an easy-to-maintain package. BAC's combined flow technology provides maximum capacity at the lowest refrigerant charge available in the industry by incorporating fill media into the traditional evaporative condenser. In addition, CXV models are designed to mount directly on existing support steel of both crossflow and counterflow units, making them a direct replacement option for almost any existing model.



**CXV-T** models are the largest factory-assembled evaporative condensers available on the market. The design is similar to that of the CXV, but on a larger scale with two air inlets instead of one. These models provide the same efficient performance and easy-to-maintain package and offer additional benefits for large projects. These benefits include fewer required cells, lower overall fan horsepower, and fewer piping connections, lowering both the cost of installation and ownership.

## Series V Models

**VC2** models are traditional style forced draft evaporative condensers with axial fans to minimize energy consumption.

**VXMC** models provide reliable, efficient operation for units in tight spaces. The nominal 10' wide unit extends the layout flexibility of the VC2 product line.





**VC1** models are traditional style evaporative condensers with centrifugal fans and are suited to applications where external ductwork or other sources of external static pressure exist.



**VC1-C** models are traditional style evaporative condensers (centrifugal fan) that are sized specifically to fit into standard dry van containers. These models minimize ocean freight costs for export shipments.

**VCL** models are centrifugal fan evaporative condensers that are specifically designed with a low profile. These units fit well into mechanical equipment rooms with low ceilings and are easily hidden behind louvered walls on buildings. Low profile models are available in heights from 5' 2-1/4" to 8' 4-3/4".



*...because temperature matters™*





# Condenser Features & Options

Standard Features	CXV	CXV-T	VC2	VXMC	VC1	VC1-C	VCL
Axial Fan	•	•	•	•			
Centrifugal Fan <sup>1</sup>					•	•	•
Large Plenum Area for Access	•	•					
Ammonia Tons	6 - 962	645 - 1,888	98 - 1,357	213 - 879	7 - 1,140	153 - 333	11 - 212
R-22 Tons	81 - 1,218	816 - 2,390	138 - 1,914	300 - 1,239	10 - 1,608	216 - 469	16 - 299
Optional Features & Accessories	CXV	CXV-T	VC2	VXMC	VC1	VC1-C	VCL
Construction Options							
Stainless Steel Cold Water Basin			•	•	•	•	
Water-Contact SST Cold Water Basin	Note 3	Note 3	•	•	•	•	•
Stainless Steel Construction	Note 3	Note 3	•	•	•	•	
Water-Contact Stainless Steel Construction			•	•	•	•	•
BALTIBOND <sup>®</sup> Corrosion Protection System	•	•	•	•	•	•	•
Coil Options							
Extended Surface Coils			•	•	•	•	•
Stainless Steel Coils	•	•	•		•	•	•
ASME "U" Stamp Coils	•	•	•		•	•	•
Multiple Circuit Coils	•	•	•	•	•	•	•
Other Options & Accessories							
ENERGY-MISER <sup>®</sup> Fan System	•	•			•	•	•
Independent Fan Operation	Note 4		•	•			
Low Sound Fan	•	•					
Sound Attenuation	•	•			•		•
Handrails w/Ladder <sup>2</sup>		•	•	•	•		
External Access Platform w/Ladder <sup>2</sup>	•	•	•	•	•		
Internal Ladder	•	•					
Internal Access Platform	•	•					
Capacity Control Dampers					•	•	•
Desuperheater Coil			•		•	•	•
Subcooling Coil	•	•	•	•	•	•	•
Gear Drive		•					
Basinless Unit Construction		•					
Factory Mutual Approval	•	•	Note 5	Note 5	Note 5	Note 5	Note 5

## Options common to all condenser styles:

### Motor Options:

- Premium Efficiency
- Inverter Duty (VFD)
- Two-Speed

### Vibration Cutout Switch

### Electric Water Level Control

### Extended Lubrication Lines (Standard on VC2)

### Basin Heaters

- Basin Sweeper Piping
- Copper Sweat Fittings
- Air Inlet/Bottom Screens

1. Centrifugal fan units can overcome e.s.p. imposed by ductwork or other restrictions. A larger fan motor may be required; contact your local sales representative for a selection.
2. Safety cages available on ladders when required by local safety standards.
3. Seams between the panels inside the cold water basin are welded for CXV and CXV-T models. The basin is leak tested at the factory and welded seams are provided with a five-year leak-proof warranty.
4. This option is available on select models of this product line. Call your local sales representative for questions regarding specific models.
5. Factory Mutual (FM) approval is typically required on evaporative condensers with PVC fill. As these models do not have PVC fill, FM Approval is not available.





# Corrosion Resistant Construction

All steel panels and structural elements are constructed of heavy-gauge G-235 hot-dip galvanized steel. The inlet louvers of CXV & CXV-T models and the casing panels of CXV-T Models are constructed of UV-resistant, fiberglass reinforced polyester (FRP).

BAC's standard condensing coil is constructed of continuous lengths of all prime surface steel, hot-dip galvanized after fabrication (HDGAF). All coils are designed for low pressure drop with sloping tubes for free drainage of fluid. Each coil is pneumatically tested at 375 psig (2,586 kPa) and is ASME B31.5 compliant. Condensing coils shipping into Canada are supplied with a CRN.

For additional corrosion resistance, the following options are available: for availability (see table on J4)

- **Optional BALTIBOND® Corrosion Protection System:**

The BALTIBOND® Corrosion Protection System, a hybrid polymer coating used to extend equipment life, is applied to all hot-dip galvanized steel components of the evaporative condenser (excluding condensing coil).

- **Optional Stainless Steel Cold Water Basin:**

A Series 300 stainless steel cold water basin is provided.

- **Optional Stainless Steel Construction:**

Steel panels and structural elements are constructed of Series 300 stainless steel.

- **Optional Water-Contact Stainless Steel Cold Water Basin:**

A cost effective alternative to an all stainless steel cold water basin, all critical components in the cold water basin are provided in Series 300 stainless steel. The remaining components are constructed of the base material of construction (galvanized steel or the BALTIBOND® Corrosion Protection System).

- **Optional Water-Contact Stainless Steel Construction:**

A cost effective alternative to all stainless steel construction, all components that are exposed to the recirculating water are provided in Series 300 stainless steel. The remaining components are constructed of the base material of construction (galvanized steel or the BALTIBOND® Corrosion Protection System).

- **Optional Stainless Steel Coil:**

Coils are available in Series 300 stainless steel for specialized applications.



Unit with BALTIBOND® Corrosion Protection System

**Welded Cold Water Basins!**  
CXV & CXV-T Models: Seams between panels inside the cold water basin are welded. The basin is leak tested at the factory and welded seams are provided with a five-year leak-proof warranty.

# Low Sound

The low sound levels generated by BAC Evaporative Condensers make them suitable for installation in most environments. Although axial fan units such as the VC2, CXV & CXV-T can meet the sound requirements of most installations, centrifugal fan models such as the VC1 and VCL should be considered for extremely sound sensitive installations.

To evaluate whether an axial fan unit can be applied on a particular application, follow these steps to minimize the impact of sound on the environment. These suggestions are ordered with regard to the impact they will have on cost. The first couple of suggestions cost very little, while later suggestions may have a significant impact on the cost of the project.

1. Position the quietest side of the equipment towards the sound sensitive direction. CXV and VC2 models have a single air inlet and therefore have an inherently quiet “blankoff” panel (the panel opposite the air inlet) that can insulate sensitive areas from higher sound levels.
2. For CXV & CXV-T models, consider oversizing the unit and reducing the fan speed. This method will reduce sound levels when the larger unit has the same fan diameter. Contact your local BAC Representative for assistance with this type of evaluation.
3. Provide a method of capacity control (see next page for capacity control options). Capacity control will allow the fan to run at lower speeds when loads are lighter or the wet-bulb is lower. These lower speeds are often sufficient to provide the scheduled capacity at night, when sound requirements are the most stringent.
4. For CXV & CXV-T models, a low sound fan option is available to significantly reduce the sound levels generated from the unit.
5. Factory designed, tested and rated sound attenuation is available for both the air intake and discharge for further sound attenuation.
6. Barrier walls can be constructed to prevent sound transmission to sensitive areas.



Unit with intake and discharge sound attenuation



# Capacity Control

Evaporative condensers provide lower condensing temperatures and can offer significant horsepower savings over conventional air-cooled and water-cooled condensing systems. The owner saves money while conserving natural resources and reducing environmental impact. Energy consumption can be further reduced via the following capacity control options:

## Variable Frequency Drives

Precise capacity control and energy savings are achieved with the BAC variable frequency drive (VFD) option. VFDs offer a more efficient and reliable way to reduce fan speed compared to fan cycling, fan discharge dampers, or mechanical speed changers.

The inherent ability for VFDs to provide soft starts, stops, and smooth accelerations prolongs the mechanical system life (fans, motors, belts, bearings, etc.). Sound levels are also reduced at lower fan speeds, and start-up noise is eliminated with the soft start feature. See page J8 for information on BAC's enclosed control and variable frequency drive offerings.

**NOTE:** An inverter duty motor is required for all models operating with a variable frequency drive.

## ENERGY-MISER® Fan System

The ENERGY-MISER® Fan System consists of two standard single-speed fan motors and drive assemblies. One drive assembly is sized for full speed and load, and the other is sized approximately 2/3 speed and consumes only 1/3 the design horsepower. This configuration allows the system to be operated like a two-speed motor, but with the reserve capacity of a standby motor in the event of failure. As a minimum, approximately 70% capacity will be available from the low horsepower motor, even on a design wet-bulb day. Controls and wiring are the same as those required for a two-speed, two-winding motor. Significant energy savings are achieved when operating at low speed during periods of reduced load and/or low wet-bulb temperatures.



ENERGY-MISER® Fan System

## BALTIGUARD PLUS™ Fan System

The BALTIGUARD PLUS™ Fan System builds on the advantages of the ENERGY-MISER® Fan System by adding a VFD to the smaller motor. Using the VFD on the smaller fan motor, as opposed to the larger motor, reduces the cost of the VFD, and wiring for the motor.

## Independent Fan Operation

The Independent Fan option consists of one fan motor and drive assembly for each fan to allow independent operation, adding redundancy and an additional step of fan cycling and capacity control to models with more than one fan.

See Page J8 for information  
on BAC Controls!

*...because temperature matters™*





# BAC Controls

## VFD:

- 1 **Ventilation Hood**
  - Required for NEMA 3R Drives
- 2 **Circuit Breaker**
  - Easily re-settable
  - Adjustable trip point
- 3 **VFD Keypad/Keypad Connector**
  - Standard keypad w/Hand-Off Auto & Bypass
  - Monitors Fan Speed, Actual Temp/Pressure or Set-point Water Temp/Pressure
  - Ready, Run and Fault lights
  - Programmable buttons & lights
  - Multi-Monitor Display
  - RS-232 connection provides compatibility interface with a PC to troubleshoot or reprogram the VFD
- 4 **24VDC Power Supply**
  - Smallest & lightest components
  - 24VDC power supply ensures redundancy
- 5 **Space Heater**
  - Maintains minimum operating temperature inside panel
  - Thermostat control
- 6 **3-Contactor Bypass**
  - Allows motor to be transferred to utility line
  - Manual or automatic bypass

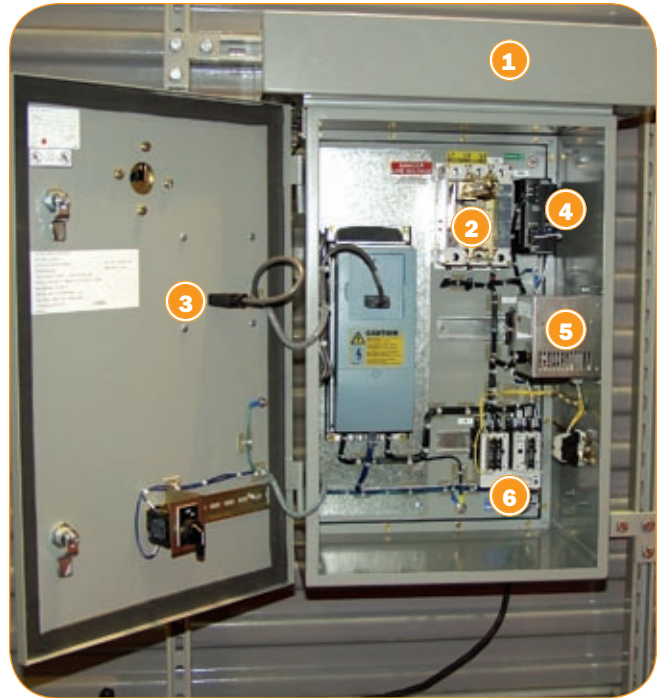

VFD - (NEMA 3R Shown)

## Enclosed Controls:

- 1 **120V Transformer**
  - Provides 120V, single-phase control circuit power from high voltage, three-phase supply (from 200-575V)
- 2 **Main Circuit Breaker**
  - Easily re-settable
  - Adjustable trip point
- 3 **Disconnect Switch**
  - Lockable operator handle
  - Mechanically tied to the Main Circuit Breaker
- 4 **Hand-Off-Auto Switches, Pilot Lights & Buttons**
  - Pilot Lights for each starter and accessory
  - Basin Heater Contactor
  - Vibration Cutout Switch Remote Reset Button
- 5 **Main Fan Motor Starter**
  - Full voltage, non-reversing starter
  - NEMA rated starters (25A and Above)
  - IEC rated starters (25A and Below)
- 6 **Programmable Logic Controller/Operator Interface**
  - Externally mounted controller monitors and adjusts desired parameters



Enclosed Controls - (NEMA 3R Shown)



Your Local BAC  
Representative can provide  
additional assistance



## Safety Disconnect Switch:

- 1 **Clear Line Shield**
  - Protects the operator from contact with wires
- 2 **Operator Handle**
  - Triple locking capability
  - Prevents unauthorized access to the interior of the enclosure
- 3 **Door Labels Include**
  - Full lug wire size ranges and torque values
  - Parts list
  - Catalog numbers of UL listed accessories
  - Maximum HP ratings
- 4 **Enclosure Interlock**
  - Prevents the front door from being opened while the disconnect handle is in the ON position
- 5 **Contacts**
  - Visible double-break rotary mechanism
  - Two points of contact provide a positive open and close, easier operation and also help prevent help contact burning for longer contact life
- 6 **Ground Lug**
  - Provided for wiring convenience



Safety Disconnect Switch -  
(NEMA 3R Shown)

# CXV Spotlight

## Reduced Scale Potential

BAC's innovative combined flow technology, applied on CXV & CXV-T Evaporative Condensers, is used to reduce the tendency to accumulate fouling and scale on the coil's exterior surface. Fouling is the build-up of solids, often calcium and magnesium compounds, resulting from the evaporation of water within the unit. By reducing fouling tendency, units are able to sustain peak heat transfer capability over the life of the equipment and maximize coil longevity. This saves time, money and energy in the installation, operation, and routine maintenance of equipment. Four facets of the unique product design contribute to the reduced tendency for fouling:

- The air and water flow in a parallel path; eliminating scale-producing dry spots on the coil
- Increased water flow over the coil is more than twice that of conventional designs to provide continuous flooding of the primary heat transfer surface
- Evaporative cooling occurs primarily in the fill
- Colder spray water keeps scale-forming compounds in solution

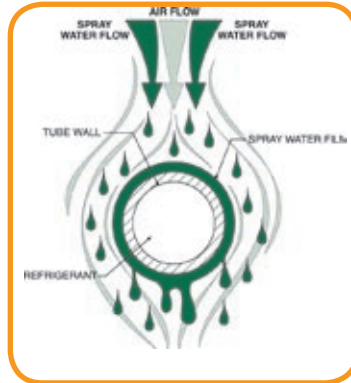

Advanced Coil Technology

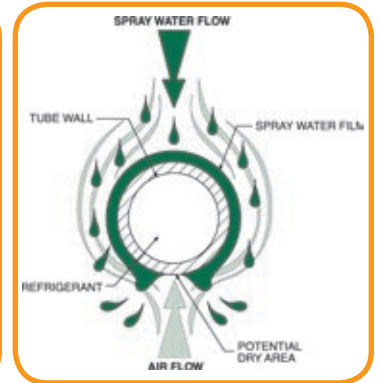

Conventional Designs

## Reduced Refrigerant Charge

The combined flow technology utilized on CXV & CXV-T models provides maximum capacity at the lowest refrigerant charge available in the industry. Reduced refrigerant charge lowers installation costs and may help satisfy refrigerant charge thresholds. Lower refrigerant charge means fewer coil connections and also leads to a reduction in cost through savings on pipe, valves, purgers, and labor.

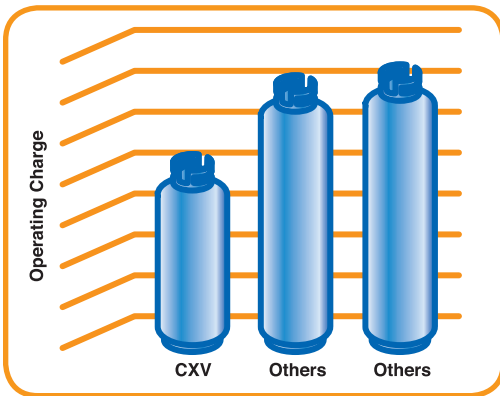

## Easy Maintenance

Hinged access doors on each end wall of CXV & CXV-T models provide easy access to the unit interior. The spacious plenum area of these models provides easy access to the cold water basin, drift eliminators, fan drive system and condensing coil.

Parallel flow of air and spray water over the condensing coil allows access to and inspection of the top of the coil during full operation.





# CXV Series Principle of Operation



Refrigeration

Water is sprayed in parallel with the fresh ambient air flowing over the outside of the condensing coil. Parallel air and water paths minimize scale-producing dry spots that may be found on the bottom of the tubes in other, conventional condensers.

The cooled water increases the temperature differential between the water and the refrigerant, which permits the CXV to deliver a reduced coil size, fewer coil connections, a lower refrigerant charge, and reduced unit weights. This facet further reduces the tendency to form scale on the coil since cooler water offers higher solubility for scale producing compounds.

The condensing coil rejects heat through both evaporative cooling using the fresh air stream and, more significantly, through sensible cooling using the pre-cooled recirculating spray water. Reducing this evaporative cooling component from the coil section helps to minimize the propensity to form scale on the relatively hot coil surface.

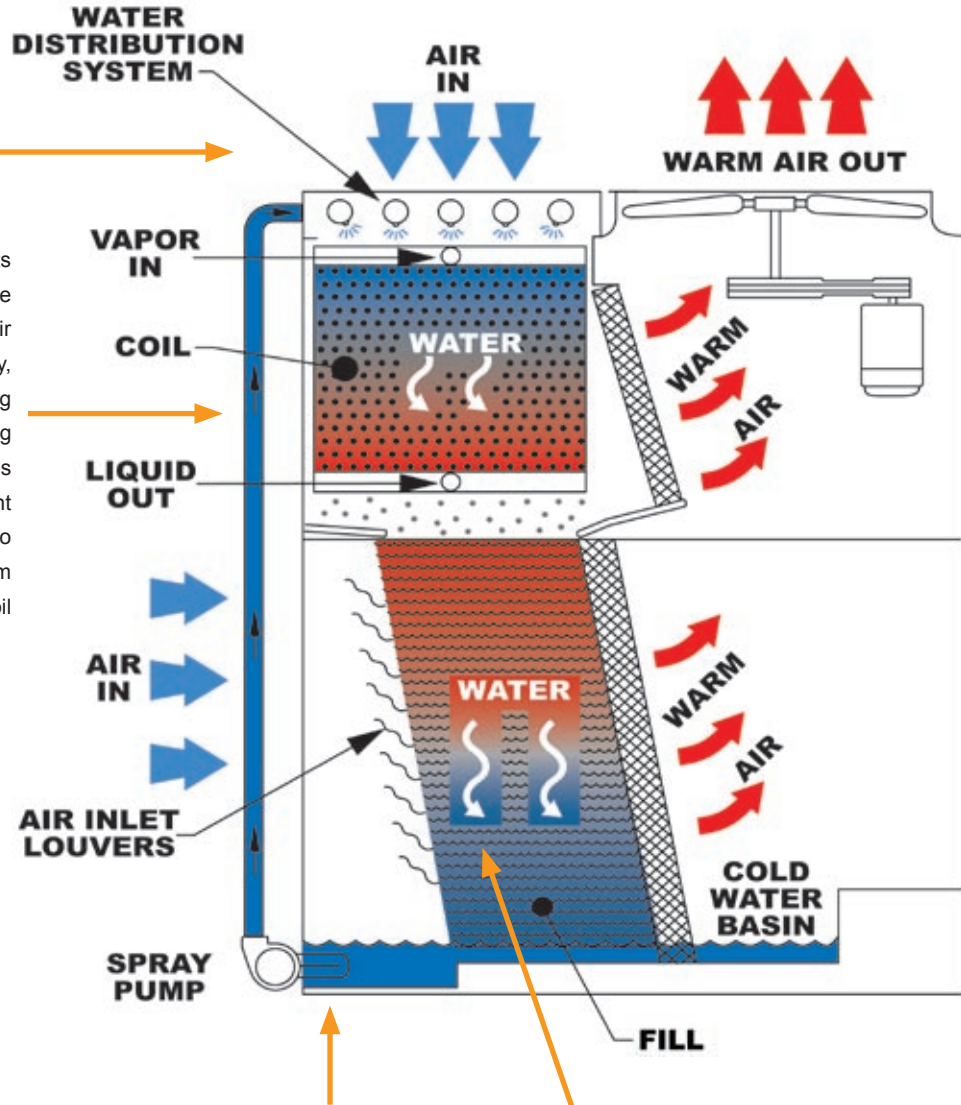

Water is pumped over the condensing coil at a rate of 10 GPM/ft<sup>2</sup> of coil face area to ensure continuous flooding of the primary heat transfer surface which enhances heat transfer efficiency and minimizes scale formation.

The recirculating spray water falls from the coil to a fill surface section where it is cooled by a second fresh air stream using both evaporative and sensible heat transfer processes.

*...because temperature matters™*



# Series V Spotlight

## Easy Maintenance

The fans, motor, and drive system of Series V units (VC2, VC1, VC1-C, & VCL models) are located outside of the moist discharge air stream, protecting them from moisture condensation and icing, and facilitating maintenance.



External drive system



Low profile

## Ducted Installations

VC1 and VCL models are provided with centrifugal fans suitable for applications where external ductwork or other sources of external static pressure exist.

## Low Profile Models

VCL models fit well into mechanical equipment rooms with low ceilings and are easily hidden behind louvered walls on buildings. Low profile models are available in heights from 5' 2-1/4" to 8' 4-3/4".

## Economical Export

VC1-C models are sized specifically to fit into standard dry van containers. These models minimize ocean freight costs for export shipments.



Dry van container

## Principle of Operation

The vapor to be condensed is circulated through a condensing coil, which is continually wetted on the outside by a recirculating water system. Air is simultaneously blown upward over the coil, causing a small portion of the water to evaporate. This evaporation removes heat from the coil, cooling and condensing the vapor in the coil.

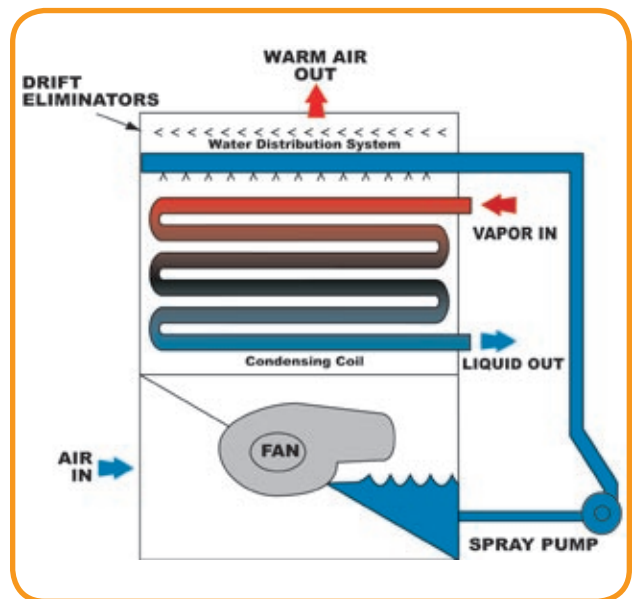

# BAC 360™ Spray Nozzle

Reduce maintenance costs and ensure efficient equipment operation with BAC's non-clog nozzle that combines scatter diffusion technology with BAC's largest nozzle orifice yet, to create the most technologically advanced spray nozzle in the industry!

## Features and Benefits

- **Ease of Maintenance**
  - Easy snap in/out grommet design
  - Anti-scale design
- **Large non-clog orifice**
- **Robust, durable construction**
- **Universal alignment**
- **No moving parts**
- **Eliminates dry spots inherent in other designs**



BAC 360™ Spray Nozzles can easily replace nozzles in existing BAC units and other manufacturers' units too!

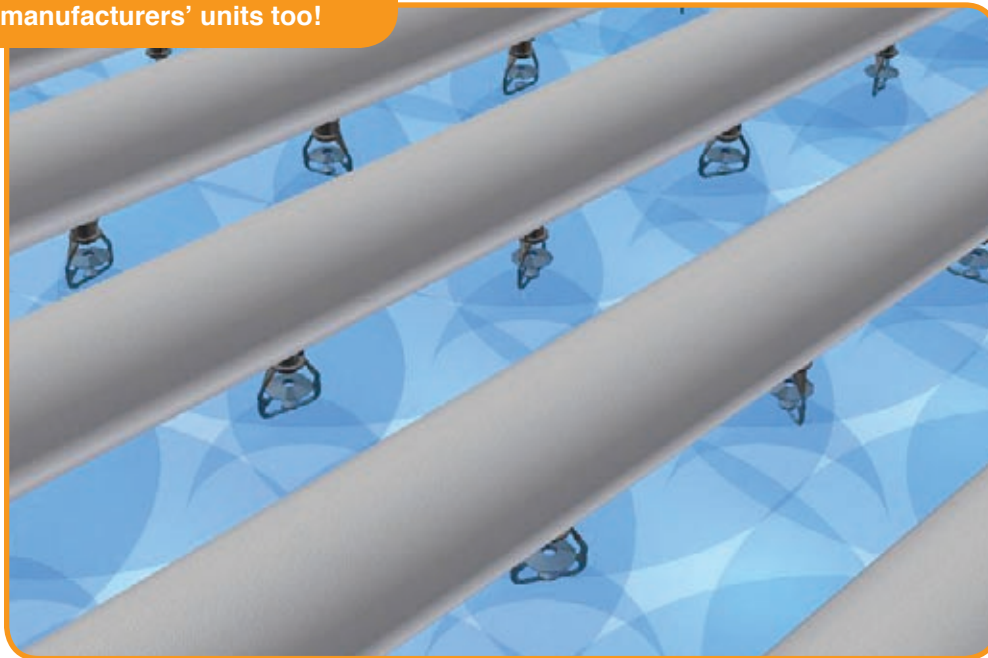

Refrigeration

*...because temperature matters™*





# Construction Details CXV Models

*Evaporative Condensers*

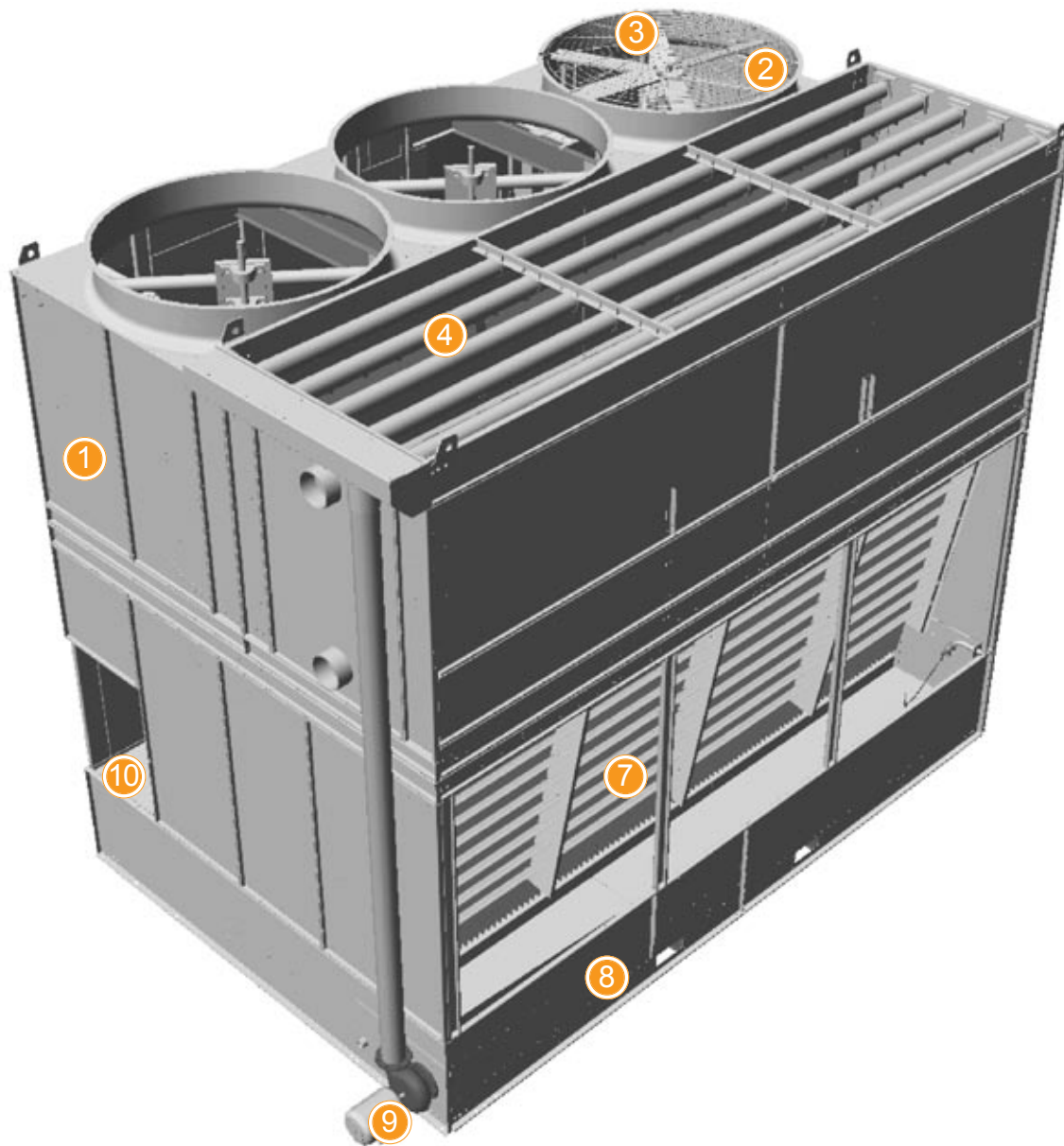



## 1 Heavy-Duty Construction

- G-235 (Z700 metric) hot-dip galvanized steel panels

## 2 BALTIDRIVE® Power Train

- Premium quality, solid-backed, multi-groove belt
- Corrosion resistant cast aluminum sheaves
- Heavy-duty bearings (280,000 hour average life)
- Cooling tower duty fan motor
- 5-year motor and drive warranty



## 3 Low HP Axial Fan(s)

- Quiet operation
- Corrosion resistant

## 4 Water Distribution System

- Visible and accessible during operation
- Overlapping spray patterns ensure proper water coverage
- Large orifice, 360° non-clog nozzles

## 5 Coil Section (Not Shown)

- Continuous serpentine, steel tubing
- Hot-dip galvanized after fabrication (HDGAF)
- Pneumatically tested at 375 psig
- Sloped tubes for free drainage of fluid
- ASME B31.5 compliant
- Orders shipping into Canada are supplied with a CRN

## 6 BACross® Fill with Integral Drift Eliminators (Not Shown)

- Polyvinyl chloride (PVC)
- Impervious to rot, decay and biological attack
- Flame spread rating of 5 per ASTM E84-77a

## 7 FRP Air Inlet Louvers

- Corrosion resistant
- UV resistant finish
- Maintenance free

## 8 Cold Water Basin

- Sloped cold water basin for easy cleaning
- Suction strainer with anti-vortex hood accessible from louver face
- Adjustable water make-up assembly accessible from louver face
- Integral internal walkway

## 9 Recirculating Spray Water Pump

- Close coupled, bronze fitted centrifugal pump
- Totally enclosed fan cooled (TEFC) motor
- Bleed line with metering valve installed from pump discharge to overflow

## 10 Hinged Access Doors

- Inward swinging door on each end wall

# Construction Details CXV-T Models

*Evaporative Condensers*

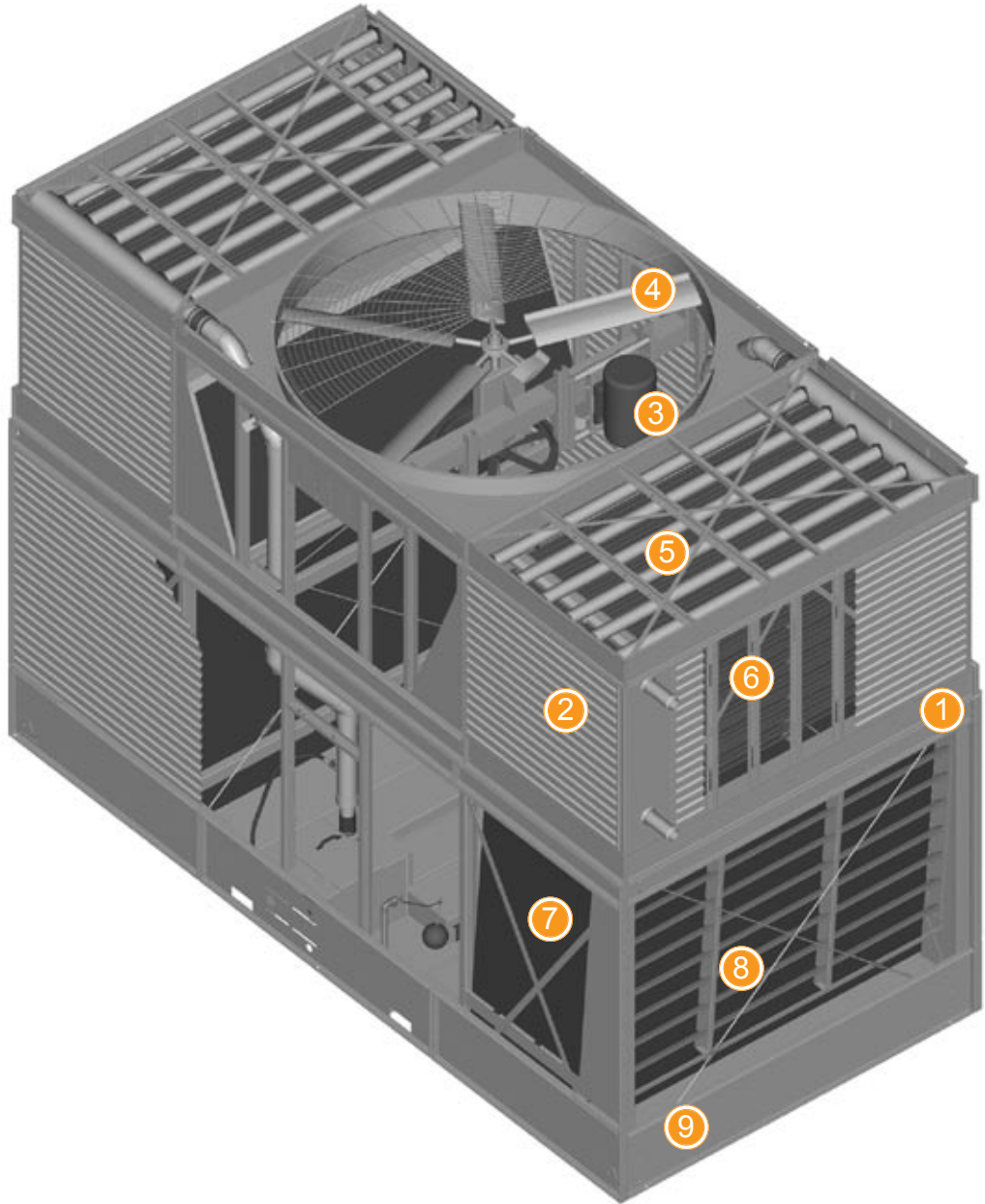





## 1 Heavy-Duty Construction

- G-235 (Z700 metric) hot-dip galvanized steel panels

## 2 FRP Casing Panels

- Corrosion resistant
- Maintenance free
- UV resistant finish

## 3 BALTIDRIVE® Power Train

- Premium quality, solid backed, multi-groove belt
- Corrosion resistant cast aluminum sheaves
- Heavy-duty bearings (280,000 hour average life)
- Cooling tower duty fan motor
- 5-year motor and drive warranty



## 4 Low HP Axial Fan

- Quiet operation
- Corrosion resistant

## 5 Water Distribution System

- Visible and accessible during operation
- Overlapping spray patterns ensure proper water coverage
- Large orifice, 360° non-clog nozzles

## 6 Coil Sections

- Continuous serpentine, steel tubing
- Hot-dip galvanized after fabrication (HDGAF)
- Pneumatically tested at 375 psig
- Sloped tubes for free drainage of fluid
- ASME B31.5 compliant
- Orders shipping into Canada are supplied with a CRN

## 7 BACross® Fill with Integral Drift Eliminators

- Polyvinyl chloride (PVC)
- Impervious to rot, decay and biological attack
- Flame spread rating of 5 per ASTM E84-77a

## 8 FRP Air Inlet Louvers

- Corrosion resistant
- UV resistant finish
- Maintenance free

## 9 Cold Water Basin

- Sloped cold water basin for easy cleaning
- Suction strainer with anti-vortex hood
- Adjustable water make-up assembly

## 10 Integral Recirculating Spray Water Pumps (Not Shown)

- Close coupled, bronze fitted centrifugal pumps
- Totally enclosed fan cooled (TEFC) motors
- Bleed line with metering valve installed from pump discharge to overflow

## 11 Hinged Access Doors (Not Shown)

- Inward swinging door on each end wall

# Construction Details Series V Models

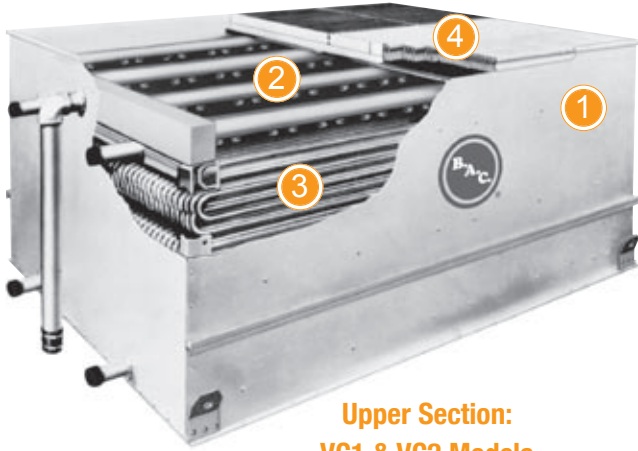

Upper Section:  
VC1 & VC2 Models

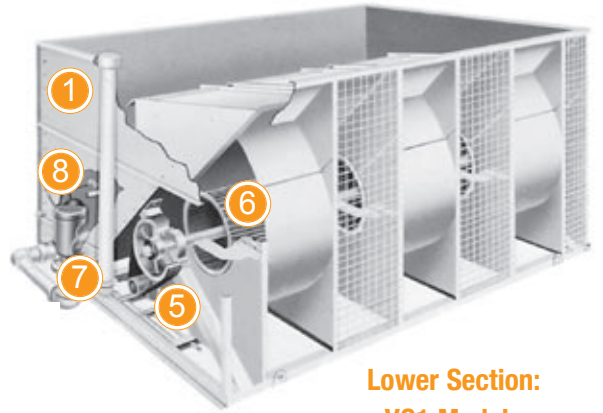

Lower Section:  
VC1 Models

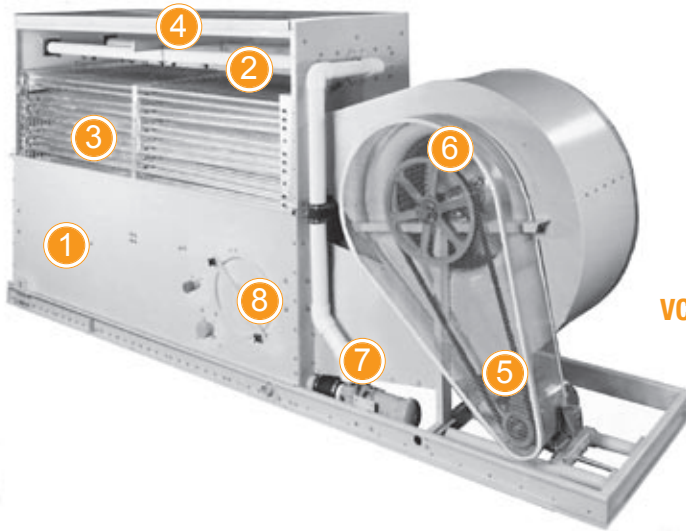

VCL Models

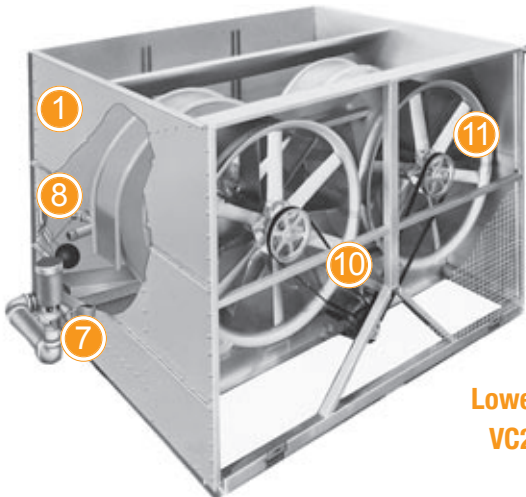

Lower Section:  
VC2 Models

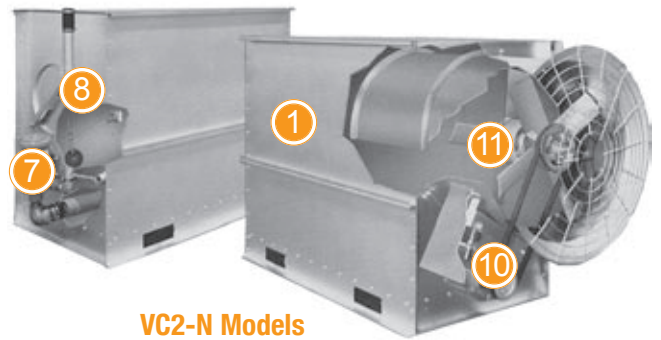

VC2-N Models





**1 Heavy Duty Construction**

- G-235 (Z700 metric) hot-dip galvanized steel panels

**2 Water Distribution System**

- Schedule 40 PVC spray branches
- Large orifice, non-clog nozzles
- Grommetted for easy maintenance

**3 Coil**

- Continuous serpentine, steel tubing
- Hot-dip galvanized after fabrication (HDGAF)
- Pneumatically tested at 375 psig
- Sloped tubes for free drainage of fluid
- ASME B31.5 compliant
- Orders shipping into Canada are supplied with a CRN

**4 Drift Eliminators**

- Polyvinyl chloride (PVC)
- Impervious to rot, decay and biological attack
- Flame spread rating of 5 per ASTM E84-77a
- Assembled in easy to handle sections

**5 Fan Drive System (VC1/VCL Models)**

- V-belt drive
- Heavy-duty bearings (280,000 hour average life)
- Cooling tower duty fan motor
- 5-year motor and drive warranty



**6 Low Sound Centrifugal Fan(s) (VC1/VCL Models)**

- Quiet operation

**7 Recirculating Spray Pump**

- Close coupled, bronze fitted centrifugal pump
- Totally enclosed fan cooled (TEFC) motor
- Bleed line with metering valve installed from pump discharge to overflow

**8 Access Door**

- Circular access door

**9 Strainer (Not Shown)**

- Anti-vortexing design to prevent air entrainment

**10 Fan Drive System (VC2 Models Only)**

- V-belt drive
- Heavy-duty bearings (280,000 hour average life)
- Extended lubrication lines
- Cooling tower duty fan motor
- 5-year motor and drive warranty



**11 Low HP Axial Fan(s) (VC2 Models)**

- Corrosion resistant





# Options and Accessories

## External Service Platforms

For external service, louver face and access door platforms can be added to the unit for easy access to the drift eliminators and spray system. Safety gates are available for all handrail openings. All components are designed to meet OSHA requirements.



External platform at louver face with ladder and safety cage

## Ladder, Safety Cage, Gate and Handrails

In the event the end-user elects to provide access to the top of the unit, units can be furnished with ladders, safety cages, safety gates and handrail packages. All components are designed to meet OSHA requirements. All access to the top of the equipment must be made in accordance with applicable governmental occupational safety standards.

**NOTE:** When these access options are employed, VC2 & VC1 models must be equipped with steel drift eliminators.

**NOTE:** For CXV-T models, partial or full grating above the coil air intake is recommended with this option.

## Internal Ladder

An internal ladder is available for access to motor and drive assemblies.

## Internal Service Platforms

An upper service platform with ladder and handrails is available for access to the motor and drive assemblies on stacked CXV and CXV-T units. Safety gates are available for handrail openings. All components are designed to meet OSHA requirements.



Internal ladder and service platform

## Vibration Cutout Switch

A factory mounted vibration cutout switch is available to effectively protect against equipment failure due to excessive vibration of the mechanical equipment system. BAC can provide either a mechanical or solid-state electronic vibration cutout switch in a NEMA 4 enclosure to ensure reliable protection. Additional contacts can be provided to activate an alarm.

## Basin Heaters

Evaporative condensers exposed to below freezing ambient temperatures require protection to prevent freezing of the water in the cold water basin when the unit is idle. Factory-installed heaters, which maintain +40°F (4.4°C) water temperature, are a simple and inexpensive way of providing such protection.



# Heater Sizing Data

## CXV Heater Sizing

Model Numbers	0°F (-17.8°C) Ambient Heaters		-20°F (-28.9°C) Ambient Heaters	
	No. of Heaters	kW per Heater	No. of Heaters	kW per Heater
CXV-64 thru 95	1	4	1	6
CXV-103 thru 153	1	6	1	8
CXV-160 thru 192, 206	1	8	1	12
CXV-196 thru 305	1	12	1	16
CXV-310 thru 481	1	16	1	21
CXV-N465 thru N687	2	10	2	15
CXV-420 thru 610	2	12	2	16
CXV-620 thru 962	2	16	2	21
CXV-T645 thru T792	2	12	2	15
CXV-T791 thru T944	2	14	2	20
CXV-T1290 thru T1584	4	12	4	15
CXV-T1654 thru T1888	4	14	4	20

## Series V Heater Sizing

Model Numbers	0°F (-17.8°C) Ambient Heaters		-20°F (-28.9°C) Ambient Heaters	
	No. of Heaters	kW per Heater	No. of Heaters	kW per Heater
VC2-N138 thru N191	1	5	1	9
VC2-N206 thru N235	1	7	1	10
VC2-N261 thru N301	1	8	1	10
VC2-N356 thru N446	1	12	1	16
VC2-319 thru 626	1	10	1	16
VC2-526 thru 957	1	16	1	20
VC2-N870 thru N1204	2	10	2	16
VC2-684 thru 1252	2	10	2	16
VC2-1052 thru 1914	2	16	2	20
VXMC-300 thru 380	1	8	1	12
VXMC-430 thru 620	1	12	1	18
VXMC-600 thru 760	2	8	2	12
VXMC-860 thru 1240	2	12	2	18
VC1-10 thru 25	1	2	1	2
VC1-30 thru 65	1	2	1	2
VC1-72 thru 90	1	2	1	3
VC1-100 thru 135	1	3	1	5
VC1-150 thru 205	1	3	1	5
VC1-N208 thru N230	1	5	1	7.5
VC1-N243 thru N315	1	5	1	7.5
VC1-C216 thru C320	1	5	1	7.5
VC1-N338 thru N470	1	7	1	10
VC1-C339 thru C469	1	5	1	7.5
VC1-386 thru 516	1	8	1	10
VC1-540 thru 804	1	12	1	16
VC1-772 thru 1032	2	8	2	10
VC1-1158 thru 1608	2	12	2	16
VCL-016 thru 035	1	2	1	2
VCL-038 thru 079	1	3	1	4
VCL-087 thru 120	1	4	1	5
VCL-134 thru 155	1	5	1	7
VCL-167 thru 234	1	7	1	9
VCL-257 thru 299	1	9	1	12

...because temperature matters™



# Options and Accessories



## Electric Water Level Control Package

The electric water level control replaces the standard mechanical make-up valve when a more precise water level control is required. This package consists of a conductance-actuated level control mounted in the basin and a solenoid activated valve in the make-up water line. The valve is slow closing to minimize water hammer.

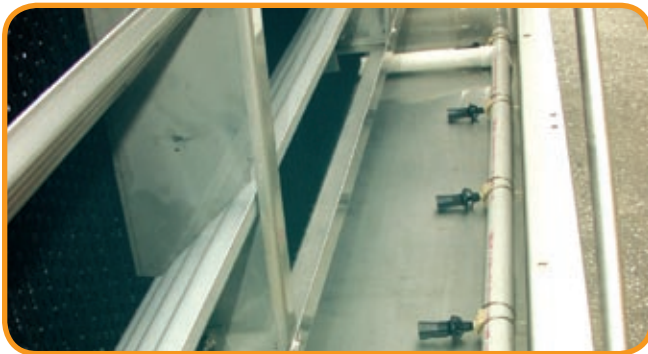

## Basin Sweeper Piping

Basin sweeper piping provides an effective method of preventing debris from collecting in the cold water basin of the unit. A complete piping system is provided in the cold water basin for connection to side stream filtration equipment (by others). Specific design varies by model.

## Capacity Control Dampers

Modulating capacity control dampers are available to provide better capacity control than can be obtained from fan cycling alone. A standard electrical control package for dampers is available.

## Extended Lubrication Lines

Extended lubrication lines are available for lubrication of the fan shaft bearings. Grease fittings are located inside the plenum area next to the access door for CXV & CXV-T models, and outside the fan section for all other models.

**NOTE:** This option is standard on VC2 models.

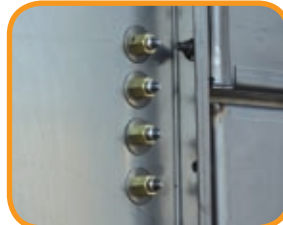

Grease fittings outside the unit



Grease fittings at the bearings

## Subcooling Coils

Subcooling coils are available for those halocarbon refrigerant installations where subcooled refrigerant is specified, or where the pressure drop or a vertical rise in the liquid line is great enough to cause excessive flashing. Standard subcooling coil sections provide approximately 10°F of subcooling at standard conditions. Subcooling sections are approximately 7" high and are mounted between the coil and basin sections. Coils are hot-dip galvanized after fabrication and pneumatically tested at 375 psig.

## Desuperheater Coils

The addition of a desuperheater coil can sometimes permit the use of a unit with a smaller plan area. The desuperheater section is mounted on top of the condenser in the discharge air stream. Coils are hot-dip galvanized after fabrication and pneumatically tested at 375 psig. Piping between the desuperheater coil and the condenser coil is not included.

## Optional Extended Surface Coil

Condensing coils are available with selected rows finned at 5 fins per inch for wet/dry applications. The coil is hot-dip galvanized after fabrication (HDGAF).

## Optional ASME "U" Stamp Coil

The condensing coil can be constructed to meet the requirements of the ASME Boiler and Pressure Vessel Code, Section VIII, Division 1, and bear the ASME "U" stamp. ASME coils are hot-dip galvanized after fabrication (HDGAF).







## Multiple Refrigerant Circuit Coil

Multiple circuit coils are generally required on halocarbon refrigerant systems, where it is common practice to maintain individual compressor systems. The quantity of circuits, capacity per circuit, and desired connection size should be specified when requesting this option.

## Auxiliary Water or Glycol Circuit

A circuit can be isolated to provide cooling of a water or glycol loop for compressor jacket cooling. The flow rate and entering temperature should be specified when requesting this option. The leaving temperature should be the same as the condensing temperature.

## Air Inlet Screens

Wire mesh screens can be factory-installed over the inlet louvers and the spray distribution system of CXV & CXV-T models to prevent debris from entering the unit.

## Bottom Screens

Wire mesh screens are available factory-installed over the bottom openings of Series V units to prevent unauthorized access.

## Solid Bottom Panels

Factory-installed bottom panels are required when the intake air is ducted to the unit.

## Copper Sweat Fittings

Optional copper sweat fittings are available to simplify field piping.



## Factory Mutual Approval

CXV & CXV-T models provided with Factory Mutual (FM) Approval must be multi-cell installations, and have galvanized steel casing panels and louvers.

## Gear Drive System, Close-Coupled Motor (CXV-T Models Only)

CXV-T Models are available with a close-coupled gear drive system. Both the gear drive and couplings are selected with a 2.0 service factor. Gear construction includes a nickel-alloy steel shaft, case hardened gears, self lubrication, and a single piece, gray iron housing. This drive system ships completely installed and aligned.



## Gear Drive System, Externally Mounted Motor (CXV-T Models Only)

A gear drive system with a TEFC motor mounted outside the airstream is also available. A non-corrosive carbon-fiber composite drive shaft with stainless steel hubs is selected with a 2.0 service factor. The motor and drive shaft ship separately for easy field installation.



## Basinless Unit Construction (CXV-T Models Only)

The basinless unit construction option enables units to be directly applied to new or existing concrete cold water basins. This custom feature, available exclusively on BAC CXV-T evaporative condensers, reduces maintenance costs by eliminating the integral basin from traditional units. It simplifies piping and pumping requirements of multi-cell installations and provides a cost-effective solution for many field-erected replacement projects.





# Selection

Two methods of unit selection are provided on the following pages. The heat rejection method is always recommended and the selection can be made via BAC's free product selection software, or manually as described below.

**NOTE:** Consult your local BAC Representative for evaporative condenser selections for systems utilizing the following:

- **Hydrocarbon refrigerants such as propane, butane, or propylene**
- **Centrifugal compressors**
- **Rotary screw compressors with water cooled oil coolers**
- **Ammonia evaporative condensers with desuperheaters**
- **Halocarbon evaporative condensers with subcooling**

## Heat Rejection Method

In a mechanical refrigeration system, the function of an evaporative condenser is to reject heat to the environment. The heat to be rejected is the sum of the heat input at the evaporator and the energy input at the compressor. For a given set of operating conditions, the energy input through the compression process can vary. Therefore, in order to accurately determine the proper evaporative condenser required, it is necessary to establish the compressor energy input as well as the heat absorbed in the evaporator.

## Selection Procedure

The Base Heat Rejection of each evaporative condenser is shown in Tables 1 through 4. Tables 5, 6 and 7 present correction factors to be applied to the system heat rejection for various condensing temperatures, wet-bulbs, and refrigerants.

1. Establish total heat rejection required in thousands of BTU per hour (MBH): Total heat rejection = compressor evaporator capacity (MBH) + compressor BHP x 2.545.
2. Determine the refrigerant and design conditions for condensing temperature and wet-bulb temperature.
3. Using the appropriate table for the system refrigerant and model (Table 5, 6 or 7), determine the correction factor for the design condensing temperature and wet-bulb temperature.
4. Multiply the total heat rejection by the correction factor determined in Step 3.
5. From Tables 1 through 4, select the evaporative condenser whose Base Heat Rejection equals or exceeds the corrected heat rejection calculated in Step 4.

Download free selection software at [www.BaltimoreAircoil.com](http://www.BaltimoreAircoil.com)

**Table 1.**  
Base Heat Rejection CXV & CXV-T

Model Number	Base Heat Rejection (MBH)	Model Number	Base Heat Rejection (MBH)
CXV-64	1,327	CXV-620	12,851
CXV-77	1,596	CXV-648	13,431
CXV-86	1,783	CXV-674	13,970
CXV-95	1,969	CXV-698	14,467
CXV-103	2,135	CXV-746	15,462
CXV-119	2,467	CXV-776	16,084
CXV-125	2,591	CXV-796	16,499
CXV-134	2,777	CXV-832	17,245
CXV-143	2,964	CXV-854	17,701
CXV-153	3,171	CXV-898	18,613
CXV-160	3,316	CXV-932	19,318
CXV-171	3,544	CXV-962	19,939
CXV-179	3,710	CXV-N465	9,638
CXV-192	3,980	CXV-N491	10,177
CXV-184	3,814	CXV-N530	10,985
CXV-206	4,270	CXV-N559	11,586
CXV-196	4,062	CXV-N574	11,897
CXV-210	4,353	CXV-N605	12,540
CXV-220	4,560	CXV-N636	13,182
CXV-235	4,871	CXV-N664	13,763
CXV-253	5,244	CXV-N687	14,239
CXV-264	5,472	CXV-T645	13,369
CXV-283	5,866	CXV-T686	14,219
CXV-290	6,011	CXV-T717	14,861
CXV-305	6,322	CXV-T729	15,110
CXV-310	6,425	CXV-T763	15,815
CXV-324	6,716	CXV-T792	16,416
CXV-337	6,985	CXV-T791	16,395
CXV-349	7,234	CXV-T827	17,141
CXV-373	7,731	CXV-T857	17,763
CXV-388	8,042	CXV-T876	18,157
CXV-398	8,249	CXV-T906	18,779
CXV-416	8,622	CXV-T944	19,566
CXV-427	8,850	CXV-T1290	26,738
CXV-449	9,306	CXV-T1372	28,437
CXV-466	9,659	CXV-T1434	29,723
CXV-481	9,970	CXV-T1458	30,220
CXV-420	8,705	CXV-T1526	31,629
CXV-470	9,742	CXV-T1584	32,832
CXV-506	10,488	CXV-T1582	32,790
CXV-528	10,944	CXV-T1654	34,282
CXV-566	11,731	CXV-T1714	35,526
CXV-580	12,022	CXV-T1752	36,314
CXV-610	12,643	CXV-T1812	37,557
		CXV-T1888	39,133





Table 2.

## Base Heat Rejection VC2 &amp; VXMC

Model Number	Base Heat Rejection (MBH)	Model Number	Base Heat Rejection (MBH)
VC2-N138	2,029	VC2-684	10,055
VC2-N150	2,205	VC2-754	11,084
VC2-N170	2,499	VC2-840	12,348
VC2-N191	2,808	VC2-902	13,259
VC2-N206	3,028	VC2-942	13,847
VC2-N215	3,161	VC2-982	14,435
VC2-N235	3,455	VC2-1026	15,082
VC2-N261	3,837	VC2-1082	15,905
VC2-N301	4,425	VC2-1160	17,052
VC2-N356	5,233	VC2-1170	17,199
VC2-N396	5,821	VC2-1252	18,404
VC2-N416	6,115	VC2-1052	15,464
VC2-N446	6,556	VC2-1162	17,081
VC2-319	4,689	VC2-1246	18,316
VC2-342	5,027	VC2-1284	18,875
VC2-377	5,542	VC2-1376	20,227
VC2-420	6,174	VC2-1422	20,903
VC2-451	6,630	VC2-1504	22,109
VC2-471	6,924	VC2-1570	23,079
VC2-491	7,218	VC2-1654	24,314
VC2-513	7,541	VC2-1774	26,078
VC2-541	7,953	VC2-1790	26,313
VC2-580	8,526	VC2-1914	28,136
VC2-585	8,600		
VC2-626	9,202	<b>VXMC</b>	
VC2-526	7,732	VXMC-300	4,410
VC2-581	8,541	VXMC-340	4,998
VC2-623	9,158	VXMC-380	5,586
VC2-642	9,437	VXMC-430	6,321
VC2-688	10,114	VXMC-460	6,762
VC2-711	10,452	VXMC-510	7,497
VC2-752	11,054	VXMC-560	8,232
VC2-785	11,540	VXMC-585	8,600
VC2-827	12,157	VXMC-620	9,114
VC2-887	13,039	VXMC-600	8,820
VC2-895	13,157	VXMC-680	9,996
VC2-957	14,068	VXMC-760	11,172
VC2-N870	12,789	VXMC-860	12,642
VC2-N932	13,700	VXMC-920	13,524
VC2-N1000	14,700	VXMC-1020	14,994
VC2-N1071	15,744	VXMC-1120	16,464
VC2-N1124	16,523	VXMC-1170	17,199
VC2-N1204	17,699	VXMC-1240	18,228

Table 3.

## Base Heat Rejection VC1 &amp; VC1-C

Model Number	Base Heat Rejection (MBH)	Model Number	Base Heat Rejection (MBH)
VC1-10	147	VC1-540	7,938
VC1-15	221	VC1-579	8,511
VC1-20	294	VC1-612	8,996
VC1-25	368	VC1-646	9,496
VC1-30	441	VC1-683	10,040
VC1-38	559	VC1-715	10,511
VC1-46	676	VC1-748	10,996
VC1-52	764	VC1-804	11,819
VC1-58	853	VC1-772	11,348
VC1-65	956	VC1-872	12,818
VC1-72	1,058	VC1-934	13,730
VC1-80	1,176	VC1-908	13,348
VC1-90	1,323	VC1-974	14,318
VC1-100	1,470	VC1-1032	15,170
VC1-110	1,617	VC1-1158	17,023
VC1-125	1,838	VC1-1224	17,993
VC1-135	1,985	VC1-1366	20,080
VC1-150	2,205	VC1-1430	21,021
VC1-165	2,426	VC1-1496	21,991
VC1-185	2,720	VC1-1608	23,638
VC1-205	3,014	VC1-C216	3,175
VC1-N208	3,058	VC1-C231	3,396
VC1-N230	3,381	VC1-C242	3,557
VC1-N243	3,572	VC1-C260	3,822
VC1-N257	3,778	VC1-C274	4,028
VC1-N275	4,043	VC1-C286	4,204
VC1-N301	4,425	VC1-C299	4,395
VC1-N315	4,631	VC1-C320	4,704
VC1-N338	4,969	VC1-C339	4,983
VC1-N357	5,248	VC1-C354	5,204
VC1-N373	5,483	VC1-C380	5,586
VC1-N417	6,130	VC1-C396	5,821
VC1-N470	6,909	VC1-C424	6,233
VC1-386	5,674	VC1-C445	6,542
VC1-436	6,409	VC1-C469	6,894
VC1-467	6,865		
VC1-454	6,674		
VC1-487	7,159		
VC1-516	7,585		

Table 4.  
Base Heat Rejection VCL

Model Number	Base Heat Rejection (MBH)
VCL-016	235
VCL-019	279
VCL-024	353
VCL-029	426
VCL-035	515
VCL-038	559
VCL-044	647
VCL-048	706
VCL-054	794
VCL-058	853
VCL-065	956
VCL-073	1,073
VCL-079	1,161
VCL-087	1,279
VCL-096	1,411
VCL-102	1,499
VCL-108	1,588
VCL-115	1,691
VCL-120	1,764
VCL-134	1,970
VCL-148	2,176
VCL-155	2,279
VCL-167	2,455
VCL-185	2,720
VCL-209	3,072
VCL-223	3,278
VCL-234	3,440
VCL-257	3,778
VCL-271	3,984
VCL-286	4,204
VCL-299	4,395

**Table 5. Heat Rejection Capacity Factors – R-717 (Ammonia)**

Condensing Pressure (psig)		Condensing Temp (°F)	Entering Wet-Bulb Temperature (°F)															
R-717			50	52	54	56	58	60	62	64	66	68	70	72	74	76	78	80
151.3	85	0.97	1.01	1.06	1.11	1.17	1.25	1.33	1.43	1.55	1.70	1.89	2.14	2.47	2.97	3.73	-	-
154.1	86	0.94	0.98	1.02	1.07	1.13	1.19	1.27	1.36	1.46	1.60	1.76	1.97	2.26	2.66	3.26	4.25	-
156.9	87	0.91	0.95	0.99	1.03	1.08	1.14	1.21	1.29	1.39	1.51	1.65	1.83	2.08	2.40	2.88	3.63	-
159.8	88	0.88	0.91	0.95	0.99	1.04	1.10	1.16	1.23	1.32	1.42	1.55	1.71	1.92	2.20	2.58	3.16	4.13
162.6	89	0.85	0.89	0.92	0.96	1.00	1.05	1.11	1.18	1.26	1.35	1.46	1.60	1.78	2.02	2.34	2.80	3.53
165.5	90	0.83	0.86	0.89	0.93	0.97	1.01	1.07	1.13	1.20	1.28	1.38	1.51	1.67	1.87	2.13	2.51	3.08
168.5	91	0.80	0.83	0.86	0.90	0.93	0.98	1.02	1.08	1.14	1.22	1.31	1.42	1.56	1.73	1.96	2.27	2.72
171.5	92	0.78	0.81	0.83	0.87	0.90	0.94	0.99	1.04	1.10	1.17	1.25	1.35	1.47	1.62	1.82	2.08	2.44
174.5	93	0.76	0.78	0.81	0.84	0.87	0.91	0.95	1.00	1.05	1.11	1.19	1.28	1.38	1.52	1.69	1.91	2.21
177.6	94	0.74	0.76	0.79	0.81	0.84	0.88	0.92	0.96	1.01	1.07	1.13	1.21	1.31	1.43	1.58	1.77	2.02
180.7	95	0.72	0.74	0.76	0.79	0.82	0.85	0.88	0.92	0.97	1.02	1.08	1.16	1.24	1.35	1.48	1.64	1.86
185.0	96.3	0.69	0.71	0.73	0.76	0.78	0.81	0.84	0.88	0.92	0.97	1.02	1.09	1.16	1.25	1.36	1.51	1.68
187.0	97	0.68	0.70	0.72	0.74	0.77	0.79	0.83	0.86	0.90	0.94	0.99	1.05	1.13	1.21	1.31	1.44	1.60
190.2	98	0.66	0.68	0.70	0.72	0.74	0.77	0.80	0.83	0.87	0.91	0.96	1.01	1.07	1.15	1.24	1.35	1.49
193.4	99	0.65	0.66	0.68	0.70	0.72	0.75	0.77	0.80	0.84	0.87	0.92	0.97	1.03	1.10	1.18	1.28	1.40
196.7	100	0.63	0.65	0.66	0.68	0.70	0.72	0.75	0.78	0.81	0.84	0.88	0.93	0.98	1.05	1.12	1.21	1.32
213.7	105	0.56	0.57	0.58	0.60	0.61	0.63	0.65	0.67	0.69	0.71	0.74	0.77	0.81	0.85	0.89	0.95	1.01
231.8	110	0.50	0.51	0.52	0.53	0.54	0.55	0.57	0.58	0.60	0.62	0.64	0.66	0.68	0.71	0.74	0.78	0.82

**Table 6. Heat Rejection Capacity Factors – R-22, R-134a (CXV Only)**

Condensing Pressure (psig)		Condensing Temp (°F)	Entering Wet-Bulb Temperature (°F)																
R-22	R-134a		50	52	54	56	58	60	62	64	66	68	70	72	74	76	78	80	82
155.7	95.2	85	1.16	1.21	1.27	1.33	1.41	1.50	1.60	1.72	1.87	2.05	2.29	2.59	3.01	3.61	4.56	-	-
158.2	97.1	86	1.13	1.17	1.23	1.29	1.36	1.44	1.53	1.64	1.77	1.94	2.14	2.40	2.75	3.24	3.98	5.21	-
160.7	98.9	87	1.09	1.14	1.19	1.24	1.31	1.38	1.46	1.56	1.68	1.83	2.01	2.23	2.53	2.94	3.53	4.46	-
163.2	100.7	88	1.06	1.10	1.15	1.20	1.26	1.32	1.40	1.49	1.14	1.23	1.89	2.09	2.34	2.69	3.17	3.89	5.09
165.8	102.6	89	1.03	1.07	1.11	1.16	1.21	1.27	1.34	1.43	1.53	1.64	1.78	1.96	2.18	2.47	2.87	3.45	4.35
168.4	104.3	90	0.99	1.03	1.07	1.12	1.16	1.22	1.29	1.36	1.45	1.56	1.68	1.84	2.03	2.29	2.62	3.09	3.79
171.0	106.2	91	0.97	1.00	1.04	1.08	1.13	1.18	1.24	1.31	1.39	1.49	1.60	1.74	1.91	2.13	2.41	2.80	3.36
173.7	108.1	92	0.94	0.97	1.01	1.04	1.09	1.14	1.19	1.26	1.33	1.42	1.52	1.65	1.80	1.99	2.23	2.56	3.02
176.4	110.0	93	0.91	0.94	0.98	1.01	1.05	1.10	1.15	1.21	1.28	1.36	1.45	1.56	1.70	1.86	2.08	2.35	2.73
179.1	111.9	94	0.89	0.92	0.95	0.98	1.02	1.06	1.11	1.17	1.23	1.30	1.39	1.49	1.61	1.76	1.94	2.18	2.50
181.8	113.9	95	0.87	0.89	0.92	0.95	0.99	1.03	1.07	1.12	1.18	1.25	1.33	1.42	1.53	1.66	1.82	2.03	2.30
184.6	115.9	96	0.84	0.87	0.90	0.93	0.96	1.00	1.04	1.09	1.14	1.20	1.27	1.35	1.45	1.57	1.71	1.90	2.13
187.4	117.5	97	0.82	0.85	0.87	0.90	0.93	0.97	1.01	1.05	1.10	1.15	1.22	1.30	1.38	1.49	1.62	1.78	1.98
190.2	119.9	98	0.80	0.82	0.85	0.88	0.91	0.94	0.97	1.01	1.06	1.11	1.17	1.24	1.32	1.42	1.53	1.68	1.85
193.0	122.1	99	0.78	0.80	0.83	0.85	0.88	0.91	0.94	0.98	1.03	1.07	1.13	1.19	1.27	1.35	1.46	1.58	1.74
195.9	124.1	100	0.76	0.78	0.81	0.83	0.86	0.88	0.92	0.95	0.99	1.04	1.09	1.14	1.21	1.29	1.39	1.50	1.64
210.7	149.6	105	0.68	0.70	0.71	0.73	0.75	0.77	0.80	0.82	0.85	0.88	0.92	0.96	1.00	1.05	1.11	1.18	1.26
226.4	146.4	110	0.61	0.62	0.64	0.65	0.67	0.68	0.70	0.72	0.74	0.76	0.79	0.82	0.85	0.89	0.93	0.97	1.03



**Table 7. Heat Rejection Capacity Factors – R-22, R-134a (Series V Only)**

Condensing Pressure (psig)		Condensing Temp (°F)	Entering Wet-Bulb Temperature (°F)																
R-22	R-134a		50	52	54	56	58	60	62	64	66	68	70	72	74	76	78	80	82
155.7	95.2	85	1.09	1.14	1.19	1.25	1.32	1.40	1.49	1.60	1.74	1.91	2.12	2.40	2.78	3.33	-	-	-
158.2	97.1	86	1.06	1.10	1.15	1.20	1.27	1.34	1.42	1.52	1.64	1.79	1.98	2.22	2.54	2.98	3.66	4.78	-
160.7	98.9	87	1.02	1.06	1.11	1.16	1.22	1.28	1.36	1.45	1.56	1.69	1.85	2.06	2.33	2.70	3.24	4.08	-
163.2	100.7	88	0.99	1.03	1.07	1.12	1.17	1.23	1.30	1.38	1.48	1.60	1.74	1.92	2.16	2.47	2.90	3.56	4.65
165.8	102.6	89	0.96	0.99	1.03	1.08	1.13	1.18	1.25	1.32	1.41	1.52	1.64	1.80	2.00	2.27	2.63	3.15	3.97
168.4	104.3	90	0.93	0.96	1.00	1.04	1.09	1.14	1.20	1.27	1.35	1.44	1.56	1.70	1.87	2.10	2.40	2.82	3.46
171.0	106.2	91	0.90	0.93	0.97	1.01	1.05	1.10	1.15	1.21	1.29	1.37	1.47	1.60	1.75	1.95	2.20	2.55	3.06
173.7	108.1	92	0.88	0.91	0.94	0.97	1.01	1.06	1.11	1.16	1.23	1.31	1.40	1.51	1.65	1.82	2.04	2.33	2.74
176.4	110.0	93	0.85	0.88	0.91	0.94	0.98	1.02	1.07	1.12	1.18	1.25	1.33	1.43	1.56	1.71	1.90	2.14	2.49
179.1	111.9	94	0.83	0.85	0.88	0.91	0.95	0.98	1.03	1.08	1.13	1.20	1.27	1.35	1.47	1.60	1.77	1.98	2.27
181.8	113.9	95	0.81	0.83	0.86	0.88	0.92	0.95	0.99	1.04	1.09	1.15	1.22	1.30	1.40	1.51	1.66	1.84	2.09
184.6	115.9	96	0.79	0.81	0.83	0.86	0.89	0.92	0.96	1.00	1.05	1.10	1.17	1.24	1.33	1.43	1.56	1.72	1.93
187.4	117.5	97	0.76	0.79	0.81	0.83	0.86	0.89	0.93	0.97	1.01	1.06	1.12	1.18	1.26	1.36	1.47	1.61	1.80
190.2	119.9	98	0.75	0.76	0.79	0.81	0.84	0.86	0.90	0.93	0.97	1.02	1.07	1.13	1.21	1.29	1.39	1.52	1.68
193.0	122.1	99	0.73	0.74	0.77	0.79	0.81	0.84	0.87	0.90	0.94	0.98	1.03	1.09	1.15	1.23	1.32	1.43	1.57
195.9	124.1	100	0.71	0.73	0.74	0.77	0.79	0.81	0.84	0.87	0.91	0.95	0.99	1.04	1.10	1.17	1.26	1.36	1.48
210.7	149.6	105	0.63	0.64	0.66	0.67	0.69	0.71	0.73	0.75	0.77	0.80	0.83	0.87	0.91	0.95	1.00	1.07	1.14
226.4	146.4	110	0.56	0.57	0.58	0.60	0.61	0.62	0.64	0.65	0.67	0.69	0.71	0.74	0.77	0.85	0.83	0.87	0.92

**Selection Example**

**Given:**

R-717 refrigerant

Compressor evaporator capacity = 550 tons

Compressor BHP = 600

Condensing temperature = 95°F

Wet-bulb temperature = 76°F

**Solution:**

- Determine the total heat rejection:  
 Compressor evaporator capacity =  
 $550 \text{ TR} \times 12,000 \text{ BTUH/TR} = 6,600,000 \text{ BTUH}$   
 Compressor BHP input =  
 $600 \text{ BHP} \times 2,545 \text{ BTUH/BHP} = 1,527,000 \text{ BTUH}$   
 Total heat rejection =  $8,127,000 \text{ BTUH} = 8,127 \text{ MBH}$
- From Table 5, the heat rejection capacity factor for R-717 at 95°F condensing temperature and 76°F wet-bulb temperature is 1.35
- Multiply:  $8,127 \text{ MBH} \times 1.35 = 10,972 \text{ MBH}$
- From Table 1 select a unit with a Base Heat Rejection equal to or greater than 10,972 MBH:  
 Model CXV-N530

Contact your local BAC Representative for assistance with alternate refrigerant selections.



Refrigeration





## Evaporator Ton Method

This selection method is based on estimated horsepower requirements for open reciprocating compressors only, and cannot be considered to be precise. Critical selection of this type should be checked by the heat rejection method shown on page J24.

### Selection Procedure

1. Determine the evaporator capacity in Refrigeration Tons (one Refrigeration Ton = 12,000 BTUH)
2. Determine refrigerant and design conditions of condensing temperature, suction temperature, and wet-bulb temperature.
3. Using tables appropriate for the system refrigerant, determine two correction factors: the Evaporator Capacity Factor (Table 12 to 15) and the Suction Temperature Factor (Tables 16 and 17).
- 4) Multiply the evaporator capacity in tons by the two correction factors determined in Step 3.
- 5) From Table 8 through 11 evaporative condenser whose model number equals or exceeds the product (factors x tons) calculated in Step 4.

**Notes:** Consult your BAC Representative for evaporative condenser selections for systems utilizing refrigerants other than R-717, R-22, or R-134a and systems requiring special considerations, such as screw compressors with water cooled oil coolers, evaporative condensers with ammonia desuperheaters or halocarbon subcooling.

### Selection Example: Open Recip. Compressor

**Given:** R-134a refrigerant  
Evaporator capacity = 145 tons  
Condensing temperature = 105°F  
Suction temperature = 30°F  
Wet-bulb temperature = 80°F

#### Solution:

- From Table 13, the capacity factor for R-134a at 105°F condensing temperature and 80°F wet-bulb is 0.84.
- From Table 17, the capacity factor for R-134a at 30°F suction temperature is 1.03.
- Multiply  $145 \times 0.84 \times 1.03 = 125.5$  corrected tons.
- From Table 8, select a unit with Corrected Evaporator Tons equal or greater to 125.5: Model CXV-134.

**Table 8.**  
Base Corrected Evaporator Tons  
CXV & CXV-T

Model Number	Corrected Evaporator Tons	Model Number	Corrected Evaporator Tons
CXV-64	64	CXV-620	620
CXV-77	77	CXV-648	648
CXV-86	86	CXV-674	674
CXV-95	95	CXV-698	698
CXV-103	103	CXV-746	746
CXV-119	119	CXV-776	776
CXV-125	125	CXV-796	796
CXV-134	134	CXV-832	832
CXV-143	143	CXV-854	854
CXV-153	153	CXV-898	898
CXV-160	160	CXV-932	932
CXV-171	171	CXV-962	962
CXV-179	179	CXV-N465	465
CXV-192	192	CXV-N491	491
CXV-184	184	CXV-N530	530
CXV-206	206	CXV-N559	559
CXV-196	196	CXV-N574	574
CXV-210	210	CXV-N605	605
CXV-220	220	CXV-N636	636
CXV-235	235	CXV-N664	664
CXV-253	253	CXV-N687	687
CXV-264	264	CXV-T645	645
CXV-283	283	CXV-T686	686
CXV-290	290	CXV-T717	717
CXV-305	305	CXV-T729	729
CXV-310	310	CXV-T763	763
CXV-324	324	CXV-T792	792
CXV-337	337	CXV-T791	791
CXV-349	349	CXV-T827	827
CXV-373	373	CXV-T857	857
CXV-388	388	CXV-T876	876
CXV-398	398	CXV-T906	906
CXV-416	416	CXV-T944	944
CXV-427	427	CXV-T1290	1,290
CXV-449	449	CXV-T1372	1,372
CXV-466	466	CXV-T1434	1,434
CXV-481	481	CXV-T1458	1,458
CXV-420	420	CXV-T1526	1,526
CXV-470	470	CXV-T1584	1,584
CXV-506	506	CXV-T1582	1,582
CXV-528	528	CXV-T1654	1,654
CXV-566	566	CXV-T1714	1,714
CXV-580	580	CXV-T1752	1,752
CXV-610	610	CXV-T1812	1,812
		CXV-T1888	1,888





**Table 9.**  
Base Corrected Evaporator Tons  
VC2 & VXMC

Model Number	Corrected Evaporator Tons	Model Number	Corrected Evaporator Tons
VC2-N138	138	VC2-684	684
VC2-N150	150	VC2-754	754
VC2-N170	170	VC2-840	840
VC2-N191	191	VC2-902	902
VC2-N206	206	VC2-942	942
VC2-N215	215	VC2-982	982
VC2-N235	235	VC2-1026	1,026
VC2-N261	261	VC2-1082	1,082
VC2-N301	301	VC2-1160	1,160
VC2-N356	356	VC2-1170	1,170
VC2-N396	396	VC2-1252	1,252
VC2-N416	416	VC2-1052	1,052
VC2-N446	446	VC2-1162	1,162
VC2-319	319	VC2-1246	1,246
VC2-342	342	VC2-1284	1,284
VC2-377	377	VC2-1376	1,376
VC2-420	420	VC2-1422	1,422
VC2-451	451	VC2-1504	1,504
VC2-471	471	VC2-1570	1,570
VC2-491	491	VC2-1654	1,654
VC2-513	513	VC2-1774	1,774
VC2-541	541	VC2-1790	1,790
VC2-580	580	VC2-1914	1,914
VC2-585	585	<b>VXMC</b>	
VC2-626	626	VXMC-300	300
VC2-526	526	VXMC-340	340
VC2-581	581	VXMC-380	380
VC2-623	623	VXMC-430	430
VC2-642	642	VXMC-460	460
VC2-688	688	VXMC-510	510
VC2-711	711	VXMC-560	560
VC2-752	752	VXMC-585	585
VC2-785	785	VXMC-620	620
VC2-827	827	VXMC-600	600
VC2-887	887	VXMC-680	680
VC2-895	895	VXMC-760	760
VC2-957	957	VXMC-860	860
VC2-N870	870	VXMC-920	920
VC2-N932	932	VXMC-1020	1,020
VC2-N1000	1,000	VXMC-1120	1,120
VC2-N1071	1,071	VXMC-1170	1,170
VC2-N1124	1,124	VXMC-1240	1,240
VC2-N1204	1,204		

**Table 10.**  
Base Corrected Evaporator Tons  
VC1 & VC1-C

Model Number	Corrected Evaporator Tons	Model Number	Corrected Evaporator Tons
VC1-10	10	VC1-540	540
VC1-15	15	VC1-579	579
VC1-20	20	VC1-612	612
VC1-25	25	VC1-646	646
VC1-30	30	VC1-683	683
VC1-38	38	VC1-715	715
VC1-46	46	VC1-748	748
VC1-52	52	VC1-804	804
VC1-58	58	VC1-772	772
VC1-65	65	VC1-872	872
VC1-72	72	VC1-934	934
VC1-80	80	VC1-908	908
VC1-90	90	VC1-974	974
VC1-100	100	VC1-1032	1,032
VC1-110	110	VC1-1158	1,158
VC1-125	125	VC1-1224	1,224
VC1-135	135	VC1-1366	1,366
VC1-150	150	VC1-1430	1,430
VC1-165	165	VC1-1496	1,496
VC1-185	185	VC1-1608	1,608
VC1-205	205	VC1-C216	216
VC1-N208	208	VC1-C231	231
VC1-N230	230	VC1-C242	242
VC1-N243	243	VC1-C260	260
VC1-N257	257	VC1-C274	274
VC1-N275	275	VC1-C286	286
VC1-N301	301	VC1-C299	299
VC1-N315	315	VC1-C320	320
VC1-N338	338	VC1-C339	339
VC1-N357	357	VC1-C354	354
VC1-N373	373	VC1-C380	380
VC1-N417	417	VC1-C396	396
VC1-N470	470	VC1-C424	424
VC1-386	386	VC1-C445	445
VC1-436	436	VC1-C469	469
VC1-467	467		
VC1-454	454		
VC1-487	487		
VC1-516	516		

**Table 11.**  
Base Corrected Evaporator Tons  
VCL

Model Number	Corrected Evaporator Tons
VCL-016	16
VCL-019	19
VCL-024	24
VCL-029	29
VCL-035	35
VCL-038	38
VCL-044	44
VCL-048	48
VCL-054	54
VCL-058	58
VCL-065	65
VCL-073	73
VCL-079	79
VCL-087	87
VCL-096	96
VCL-102	102
VCL-108	108
VCL-115	115
VCL-120	120
VCL-134	134
VCL-148	148
VCL-155	155
VCL-167	167
VCL-185	185
VCL-209	209
VCL-223	223
VCL-234	234
VCL-257	257
VCL-271	271
VCL-286	286
VCL-299	299

**Table 12. Evaporator Capacity Factors – R-717 (Ammonia) (CXV Only)**

Condensing Pressure (psig)		Condensing Temp (°F)	Entering Wet-Bulb Temperature (°F)															
R-717			50	52	54	56	58	60	62	64	66	68	70	72	74	76	78	80
151.7	85	0.70	0.73	0.76	0.80	0.84	0.89	0.95	1.02	1.11	1.22	1.35	1.53	1.77	2.12	2.67	-	-
154.1	86	0.68	0.70	0.73	0.77	0.81	0.86	0.91	0.97	1.05	1.15	1.26	1.42	1.62	1.91	2.33	3.05	-
156.9	87	0.66	0.68	0.71	0.74	0.78	0.82	0.87	0.93	1.00	1.08	1.19	1.32	1.49	1.73	2.07	2.61	-
159.8	88	0.64	0.66	0.69	0.72	0.75	0.79	0.84	0.89	0.95	1.03	1.12	1.23	1.38	1.58	1.86	2.28	2.98
162.6	89	0.62	0.64	0.67	0.69	0.73	0.76	0.80	0.85	0.91	0.98	1.06	1.16	1.29	1.46	1.69	2.02	2.55
165.9	90	0.60	0.62	0.65	0.67	0.70	0.73	0.77	0.82	0.87	0.93	1.00	1.09	1.21	1.35	1.53	1.82	2.23
168.9	91	0.58	0.60	0.63	0.65	0.68	0.71	0.74	0.78	0.83	0.89	0.95	1.03	1.13	1.26	1.43	1.65	1.98
171.9	92	0.57	0.59	0.61	0.63	0.66	0.69	0.72	0.75	0.80	0.85	0.91	0.98	1.07	1.18	1.32	1.51	1.78
174.9	93	0.55	0.57	0.59	0.61	0.64	0.66	0.69	0.73	0.77	0.81	0.87	0.93	1.01	1.11	1.23	1.39	1.61
178.0	94	0.54	0.56	0.58	0.59	0.62	0.64	0.67	0.70	0.74	0.78	0.83	0.89	0.96	1.04	1.15	1.29	1.48
181.1	95	0.53	0.54	0.56	0.58	0.60	0.62	0.65	0.68	0.71	0.75	0.80	0.85	0.91	0.99	1.08	1.20	1.36
185.0	96.3	0.51	0.53	0.54	0.56	0.58	0.60	0.62	0.65	0.68	0.71	0.75	0.80	0.86	0.92	1.00	1.11	1.24
187.4	97	0.50	0.52	0.53	0.55	0.57	0.59	0.61	0.63	0.66	0.70	0.73	0.78	0.83	0.89	0.97	1.06	1.18
190.6	98	0.49	0.50	0.52	0.53	0.55	0.57	0.59	0.61	0.64	0.67	0.71	0.75	0.79	0.85	0.92	0.99	1.1
193.9	99	0.48	0.49	0.51	0.52	0.54	0.55	0.57	0.60	0.62	0.65	0.68	0.72	0.76	0.81	0.87	0.95	1.04
197.2	100	0.47	0.48	0.49	0.51	0.52	0.54	0.56	0.58	0.60	0.63	0.66	0.69	0.73	0.78	0.83	0.90	0.98
214.2	105	0.42	0.43	0.44	0.45	0.46	0.47	0.49	0.50	0.52	0.54	0.56	0.58	0.61	0.64	0.67	0.71	0.76
232.3	110	0.37	0.38	0.39	0.40	0.41	0.42	0.43	0.44	0.46	0.47	0.48	0.50	0.52	0.54	0.56	0.59	0.62

**Table 13. Evaporator Capacity Factors – R-22, R-134a (CXV Only)**

Condensing Pressure (psig)		Condensing Temp (°F)	Entering Wet-Bulb Temperature (°F)																
R-22	R-134a		50	52	54	56	58	60	62	64	66	68	70	72	74	76	78	80	82
155.7	95.2	85	0.79	0.82	0.86	0.90	0.95	1.01	1.08	1.16	1.26	1.39	1.55	1.75	2.03	2.44	3.08	-	-
158.2	97.1	86	0.77	0.80	0.83	0.87	0.92	0.98	1.04	1.11	1.20	1.31	1.45	1.63	1.87	2.20	2.70	3.53	-
160.7	98.9	87	0.74	0.77	0.81	0.84	0.89	0.94	1.00	1.06	1.14	1.24	1.36	1.52	1.72	2.00	2.40	3.03	-
163.2	100.7	88	0.72	0.75	0.78	0.82	0.86	0.90	0.96	1.02	1.09	1.18	1.29	1.42	1.60	1.83	2.16	2.65	3.47
165.8	102.6	89	0.70	0.73	0.76	0.79	0.83	0.87	0.92	0.98	1.04	1.12	1.22	1.34	1.49	1.69	1.96	2.35	2.97
168.4	104.3	90	0.68	0.71	0.73	0.76	0.80	0.84	0.89	0.93	0.99	1.07	1.15	1.26	1.39	1.56	1.79	2.11	2.59
171.0	106.2	91	0.66	0.69	0.71	0.74	0.77	0.81	0.85	0.90	0.95	1.02	1.10	1.19	1.31	1.46	1.65	1.92	2.31
173.7	108.1	92	0.65	0.67	0.69	0.72	0.75	0.78	0.82	0.86	0.92	0.98	1.05	1.13	1.24	1.37	1.53	1.76	2.07
176.4	110.0	93	0.63	0.65	0.67	0.70	0.73	0.76	0.79	0.83	0.88	0.94	1.00	1.08	1.17	1.28	1.43	1.62	1.88
179.1	111.9	94	0.61	0.63	0.66	0.68	0.70	0.73	0.77	0.81	0.85	0.90	0.96	1.03	1.11	1.21	1.34	1.51	1.73
181.8	113.9	95	0.60	0.62	0.64	0.66	0.69	0.71	0.74	0.78	0.82	0.86	0.92	0.98	1.06	1.15	1.26	1.40	1.59
184.6	115.9	96	0.59	0.60	0.62	0.64	0.67	0.69	0.72	0.75	0.79	0.83	0.88	0.94	1.01	1.09	1.19	1.32	1.48
187.4	117.5	97	0.57	0.59	0.61	0.63	0.65	0.67	0.70	0.73	0.76	0.80	0.85	0.90	0.96	1.04	1.13	1.24	1.38
190.2	119.9	98	0.56	0.58	0.59	0.61	0.63	0.65	0.68	0.71	0.74	0.78	0.82	0.87	0.92	0.99	1.07	1.17	1.29
193.0	122.1	99	0.55	0.56	0.58	0.60	0.62	0.64	0.66	0.69	0.72	0.75	0.79	0.83	0.88	0.95	1.02	1.11	1.22
195.9	124.1	100	0.54	0.55	0.56	0.58	0.60	0.62	0.64	0.67	0.69	0.73	0.76	0.80	0.85	0.91	0.97	1.05	1.15
210.7	149.6	105	0.48	0.49	0.51	0.52	0.53	0.55	0.56	0.58	0.60	0.63	0.65	0.68	0.71	0.75	0.79	0.84	0.90
226.4	146.4	110	0.44	0.45	0.46	0.47	0.48	0.49	0.50	0.52	0.53	0.55	0.57	0.59	0.61	0.64	0.67	0.70	0.74

**Contact your local BAC Representative for assistance with alternate refrigerant selections.**





**Table 14. Evaporator Capacity Factors – R-717 (Ammonia) (Series V Only)**

Condensing Pressure (psig)	Condensing Temp (°F)	Entering Wet-Bulb Temperature (°F)																
		50	52	54	56	58	60	62	64	66	68	70	72	74	76	78	80	82
R-717																		
151.7	85	0.98	1.02	1.07	1.12	1.18	1.26	1.34	1.44	1.56	1.71	1.90	2.15	2.50	2.99	-	-	-
154.1	86	0.95	0.99	1.03	1.08	1.14	1.20	1.28	1.37	1.48	1.61	1.78	1.99	2.28	2.68	3.29	4.30	-
156.9	87	0.92	0.96	1.00	1.04	1.10	1.16	1.23	1.31	1.41	1.52	1.67	1.86	2.10	2.44	2.92	3.68	-
159.8	88	0.90	0.93	0.97	1.01	1.06	1.11	1.18	1.25	1.34	1.45	1.58	1.74	1.95	2.23	2.62	3.21	4.20
162.6	89	0.87	0.90	0.94	0.98	1.02	1.07	1.13	1.20	1.28	1.37	1.49	1.63	1.82	2.05	2.38	2.85	3.59
165.9	90	0.85	0.88	0.91	0.95	0.99	1.03	1.09	1.15	1.22	1.31	1.41	1.54	1.70	1.91	2.18	2.56	3.14
168.9	91	0.82	0.85	0.88	0.92	0.95	1.00	1.05	1.11	1.17	1.25	1.34	1.46	1.60	1.78	2.01	2.33	2.79
171.9	92	0.80	0.83	0.86	0.89	0.92	0.96	1.01	1.06	1.12	1.20	1.28	1.38	1.51	1.66	1.86	2.13	2.51
174.9	93	0.78	0.81	0.83	0.86	0.90	0.93	0.98	1.02	1.08	1.15	1.22	1.31	1.42	1.56	1.74	1.96	2.27
178.0	94	0.76	0.78	0.81	0.84	0.87	0.90	0.94	0.99	1.04	1.10	1.17	1.25	1.35	1.47	1.62	1.82	2.08
181.1	95	0.74	0.76	0.79	0.81	0.84	0.88	0.91	0.95	1.00	1.06	1.12	1.19	1.28	1.39	1.53	1.70	1.92
185.0	96.3	0.72	0.74	0.76	0.79	0.81	0.84	0.88	0.91	0.96	1.01	1.06	1.13	1.21	1.30	1.41	1.56	1.74
187.4	97	0.71	0.73	0.75	0.77	0.80	0.82	0.86	0.89	0.93	0.98	1.03	1.10	1.17	1.26	1.36	1.49	1.66
190.6	98	0.69	0.71	0.73	0.75	0.77	0.80	0.83	0.86	0.90	0.95	0.99	1.05	1.12	1.20	1.29	1.41	1.55
193.9	99	0.67	0.69	0.71	0.73	0.75	0.78	0.81	0.84	0.87	0.91	0.96	1.01	1.07	1.14	1.23	1.33	1.46
197.2	100	0.66	0.68	0.69	0.71	0.73	0.76	0.78	0.81	0.85	0.88	0.92	0.97	1.03	1.09	1.17	1.26	1.38
214.2	105	0.59	0.61	0.62	0.63	0.65	0.67	0.69	0.71	0.73	0.76	0.79	0.82	0.86	0.90	0.95	1.00	1.07
232.3	110	0.54	0.55	0.56	0.57	0.58	0.59	0.61	0.62	0.64	0.66	0.68	0.71	0.73	0.76	0.79	0.83	0.88

**Table 15. Evaporator Capacity Factors – R-22, R-134a (Series V Only)**

Condensing Pressure (psig)		Condensing Temp (°F)	Entering Wet-Bulb Temperature (°F)																
R-22	R-134a		50	52	54	56	58	60	62	64	66	68	70	72	74	76	78	80	82
155.7	95.2	85	1.04	1.09	1.14	1.19	1.26	1.33	1.42	1.53	1.66	1.82	2.02	2.29	2.65	3.18	-	-	-
158.2	97.1	86	1.01	1.05	1.10	1.15	1.21	1.28	1.36	1.46	1.57	1.71	1.89	2.12	2.42	2.85	3.49	4.57	-
160.7	98.9	87	0.98	1.02	1.06	1.11	1.16	1.23	1.30	1.39	1.49	1.62	1.78	1.97	2.23	2.59	3.10	3.91	-
163.2	100.7	88	0.95	0.99	1.03	1.07	1.12	1.18	1.25	1.33	1.42	1.53	1.67	1.85	2.07	2.37	2.79	3.41	4.46
165.8	102.6	89	0.92	0.96	0.99	1.04	1.08	1.14	1.20	1.27	1.36	1.46	1.58	1.73	1.93	2.18	2.53	3.03	3.82
168.4	104.3	90	0.90	0.93	0.96	1.00	1.05	1.10	1.15	1.22	1.30	1.39	1.50	1.64	1.80	2.02	2.31	2.72	3.33
171.0	106.2	91	0.87	0.90	0.94	0.97	1.01	1.06	1.11	1.17	1.24	1.33	1.43	1.55	1.69	1.88	2.13	2.47	2.95
173.7	108.1	92	0.85	0.88	0.91	0.94	0.98	1.02	1.07	1.13	1.19	1.27	1.36	1.47	1.60	1.76	1.98	2.26	2.66
176.4	110.0	93	0.83	0.85	0.88	0.91	0.95	0.99	1.04	1.09	1.15	1.22	1.30	1.39	1.51	1.66	1.84	2.08	2.41
179.1	111.9	94	0.81	0.83	0.86	0.89	0.92	0.96	1.00	1.05	1.10	1.17	1.24	1.33	1.43	1.56	1.72	1.93	2.21
181.8	113.9	95	0.79	0.81	0.84	0.86	0.89	0.93	0.97	1.01	1.06	1.12	1.19	1.27	1.36	1.48	1.62	1.80	2.04
184.6	115.9	96	0.77	0.79	0.81	0.84	0.87	0.90	0.94	0.98	1.03	1.08	1.14	1.21	1.30	1.40	1.53	1.68	1.89
187.4	117.5	97	0.75	0.77	0.79	0.82	0.84	0.88	0.91	0.95	0.99	1.04	1.10	1.16	1.24	1.33	1.44	1.58	1.76
190.2	119.9	98	0.73	0.75	0.77	0.80	0.82	0.85	0.88	0.92	0.96	1.00	1.05	1.11	1.19	1.27	1.37	1.49	1.65
193.0	122.1	99	0.72	0.73	0.75	0.78	0.80	0.83	0.86	0.89	0.93	0.97	1.02	1.07	1.14	1.21	1.30	1.41	1.55
195.9	124.1	100	0.70	0.72	0.74	0.76	0.78	0.80	0.83	0.86	0.90	0.94	0.98	1.03	1.09	1.16	1.24	1.34	1.46
210.7	149.6	105	0.63	0.64	0.66	0.67	0.69	0.71	0.73	0.75	0.77	0.80	0.83	0.87	0.91	0.95	1.00	1.07	1.14
226.4	146.4	110	0.57	0.58	0.59	0.60	0.62	0.63	0.65	0.66	0.68	0.70	0.72	0.75	0.78	0.81	0.84	0.88	0.93

**Table 16. Suction Temperature Factors – R-717 (Ammonia)**

Suction Temperature (°F)	-20	-10	0	+10	+20	+30	+40	+50
Capacity Factor	1.14	1.11	1.07	1.04	1.00	0.98	0.95	0.93

**Table 17. Suction Temperature Factors – R-22, R-134a**

Suction Temperature (°F)	-20	-10	0	+10	+20	+30	+40	+50
Capacity Factor	1.20	1.16	1.13	1.09	1.06	1.03	1.00	0.98

*...because temperature matters™*





# Engineering Data

## Models CXV-64 to 206

See page M32 for information on sizing a remote sump tank.

**Do not use for construction.** Refer to factory certified dimensions. This handbook includes data current at the time of publication, which should be reconfirmed at the time of purchase. Up-to-date engineering data, free product selection software and more can be found at [www.BaltimoreAircoil.com](http://www.BaltimoreAircoil.com).

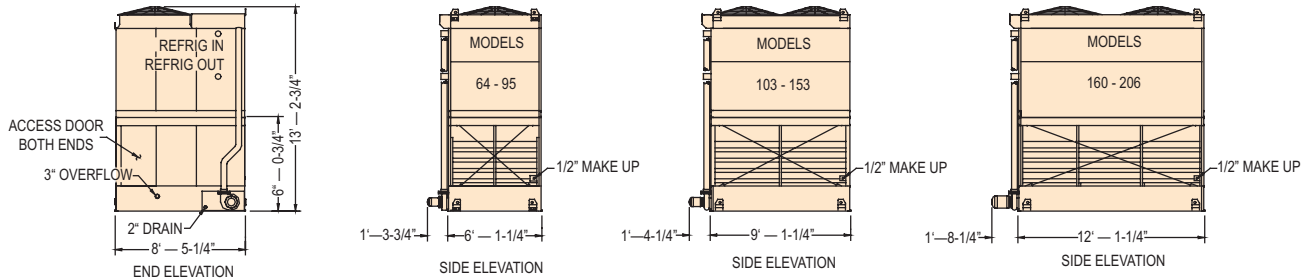

Nom. Box Size	Model Number <sup>1</sup>	Base Heat Rejection (MBH)	R-22 Tons <sup>2</sup>	Fan Motor (HP)	Airflow Rate (CFM)	Pump Motor (HP)	Approx. Weights (lbs)			Ammonia Operating Charge <sup>5</sup> (lbs)	Internal Coil Volume (ft <sup>3</sup> )	Spray Flow-rate (GPM)	Remote Sump		
							Ship.	Heaviest Section	Oper. <sup>3</sup>				Drain Size (in)	Volume Required (gal)	Approx. Oper. Wt. (lbs)
8.5' x 6'	CXV-64	1,327	81	5	28,950	1.5	5,020	2,870	7,410	51	6.2	190	6	270	7,120
	CXV-77	1,596	97	5	28,550	1.5	5,340	3,190	7,780	67	8	190	6	270	7,490
	CXV-86	1,783	109	5	27,850	1.5	5,680	3,530	8,170	84	10	190	6	270	7,880
	CXV-95	1,969	120	7.5	31,050	1.5	6,030	3,880	8,570	101	12	190	6	270	8,280
8.5' x 9'	CXV-103	2,135	130	10	48,650	2	7,160	4,240	10,800	76	9.2	290	6	290	10,470
	CXV-119	2,467	151	7.5	43,650	2	7,640	4,720	11,350	101	12	290	6	290	11,020
	CXV-125	2,591	158	10	48,000	2	7,650	4,730	11,360	101	12	290	6	290	11,030
	CXV-134	2,777	170	7.5	42,550	2	8,130	5,210	11,910	126	15	290	6	290	11,580
	CXV-143	2,964	181	10	45,650	2	8,630	5,710	12,480	151	18	290	6	290	12,150
	CXV-153	3,171	194	15	52,150	2	8,680	5,760	12,530	151	18	290	6	290	12,200
8.5' x 12'	CXV-160	3,316	203	10	58,750	3	9,360	5,720	14,330	135	16	500	8	550	13,770
	CXV-171	3,544	216	15	67,150	3	9,410	5,770	14,380	135	16	500	8	550	13,820
	CXV-179	3,710	227	10	57,250	3	10,010	6,370	15,060	168	20	500	8	550	14,520
	CXV-192	3,980	243	15	65,450	3	10,060	6,420	15,130	168	20	500	8	550	14,570
	CXV-184	3,814	233	10	55,850	3	10,670	7,030	15,830	201	24	500	8	550	15,270
	CXV-206	4,270	261	20	70,200	3	10,770	7,130	15,930	201	24	500	8	550	15,370

**Notes:**

- Model number denotes nominal ammonia capacity in evaporator tons at a 96.3°F condensing temperature, a 20°F suction temperature, and a 78°F wet-bulb temperature.
- R-22 tons are at a 105°F condensing temperature, a 40°F suction temperature, and a 78°F wet-bulb temperature.
- Operating weight is for the unit with the water level in the cold water basin at the overflow.
- For R-22 and R-134a, the coil connection quantity will double (except for the CXV-64 thru -153).
- The R-22 operating charge is 1.93 times the ammonia charge; R-134a is 1.98 times.
- Inlet and outlet connections are beveled for welding.
- Standard make-up, drain and overflow connections are MPT.



# Models CXV-196 to 481

**Do not use for construction.** Refer to factory certified dimensions. This handbook includes data current at the time of publication, which should be reconfirmed at the time of purchase. Up-to-date engineering data, free product selection software and more can be found at [www.BaltimoreAircoil.com](http://www.BaltimoreAircoil.com).

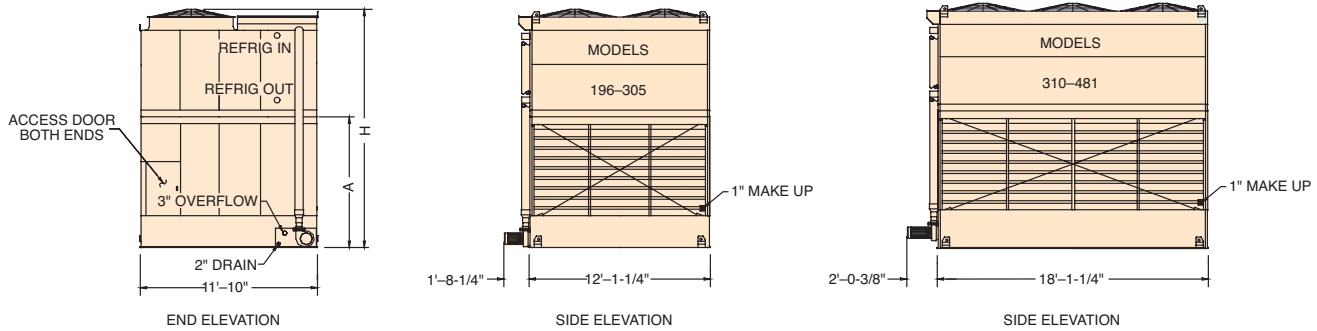

Refrigeration

Nom. Box Size	Model Number <sup>1</sup>	Base Heat Rejection (MBH)	R-22 Tons <sup>2</sup>	Fan Motor (HP)	Airflow Rate (CFM)	Pump Motor (HP)	Approx. Weights (lbs)			Ammonia Operating Charge (lbs) <sup>5</sup>	Internal Coil Volume (ft <sup>3</sup> )	Spray Flowrate (GPM)	Remote Sump			A	H
							Ship.	Heaviest Section	Oper. <sup>3</sup>				Drain Size (in)	Volume Required (gal)	Approx. Oper. Wt. (lbs)		
12' x 12'	CXV-196	4,062	248	10	68,160	5	10,740	6,580	17,480	164	20	715	10	600	16,920	8'-8 3/4"	15'-10 3/4"
	CXV-210	4,353	266	15	77,900	5	10,790	6,630	17,530	164	20	715	10	600	16,970	8'-8 3/4"	15'-10 3/4"
	CXV-220	4,560	278	20	85,650	5	10,840	6,680	17,580	164	20	715	10	600	17,020	8'-8 3/4"	15'-10 3/4"
	CXV-235	4,871	297	10	67,200	5	11,780	7,620	18,670	217	26	715	10	600	18,110	8'-8 3/4"	15'-10 3/4"
	CXV-253	5,244	320	15	76,800	5	11,830	7,670	18,720	217	26	715	10	600	18,160	8'-8 3/4"	15'-10 3/4"
	CXV-264	5,472	334	10	64,930	5	12,830	8,670	19,870	270	32	715	10	600	19,310	8'-8 3/4"	15'-10 3/4"
	CXV-283	5,866	358	15	74,200	5	12,880	8,720	19,920	270	32	715	10	600	19,360	8'-8 3/4"	15'-10 3/4"
	CXV-290	6,011	367	15	72,700	5	13,920	9,760	21,110	321	38	715	10	600	20,550	8'-8 3/4"	15'-10 3/4"
	CXV-305	6,322	386	20	79,950	5	13,970	9,810	21,160	321	38	715	10	600	20,600	8'-8 3/4"	15'-10 3/4"
12' x 18'	CXV-310	6,425	392	15/7.5	117,900	7.5	15,320	9,500	25,500	243	29	900	10	750	24,940	9'-2 1/4"	16'-4 1/4"
	CXV-324	6,716	410	10/5	129,650	7.5	15,410	9,590	25,590	243	29	900	10	750	25,030	9'-2 1/4"	16'-4 1/4"
	CXV-337	6,985	427	25/15	139,550	7.5	15,510	9,690	25,690	243	29	900	10	750	25,130	9'-2 1/4"	16'-4 1/4"
	CXV-349	7,234	442	10/5	101,760	7.5	16,810	10,990	27,210	321	39	900	10	750	26,650	9'-2 1/4"	16'-4 1/4"
	CXV-373	7,731	472	15/7.5	116,300	7.5	16,890	11,070	27,290	321	39	900	10	750	26,730	9'-2 1/4"	16'-4 1/4"
	CXV-388	8,042	491	10/5	98,310	7.5	18,400	12,580	29,030	401	48	900	10	750	28,470	9'-2 1/4"	16'-4 1/4"
	CXV-398	8,249	504	10/5	96,290	7.5	19,990	14,170	30,830	475	57	900	10	750	30,270	9'-2 1/4"	16'-4 1/4"
	CXV-416	8,622	527	15/7.5	112,350	7.5	18,480	12,660	29,110	401	48	900	10	750	28,550	9'-2 1/4"	16'-4 1/4"
	CXV-427	8,850	541	15/7.5	110,050	7.5	20,070	14,250	30,910	475	57	900	10	750	30,350	9'-2 1/4"	16'-4 1/4"
	CXV-449	9,306	568	20/10	121,050	7.5	20,150	14,330	30,990	475	57	900	10	750	30,430	9'-2 1/4"	16'-4 1/4"
	CXV-466	9,659	590	25/15	130,300	7.5	20,260	14,440	31,100	475	57	900	10	750	30,540	9'-2 1/4"	16'-4 1/4"
	CXV-481	9,970	609	30/15	138,350	7.5	20,280	14,460	31,120	475	57	900	10	750	30,560	9'-2 1/4"	16'-4 1/4"

**Notes:**

- Model number denotes nominal ammonia capacity in evaporator tons at a 96.3°F condensing temperature, a 20°F suction temperature, and a 78°F wet-bulb temperature.
- R-22 tons are at a 105°F condensing temperature, a 40°F suction temperature, and a 78°F wet-bulb temperature.
- Operating weight is for the unit with the water level in the cold water basin at the overflow.
- For R-22 and R-134a, the coil connection quantity will double (except for the CXV-64 thru -153).
- The R-22 operating charge is 1.93 times the ammonia charge; R-134a is 1.98 times.
- Inlet and outlet connections are beveled for welding.
- Standard make-up, drain and overflow connections are MPT.

...because temperature matters™



# Models CXV-420 to 962

**Do not use for construction.** Refer to factory certified dimensions. This handbook includes data current at the time of publication, which should be reconfirmed at the time of purchase. Up-to-date engineering data, free product selection software and more can be found at [www.BaltimoreAircoil.com](http://www.BaltimoreAircoil.com).

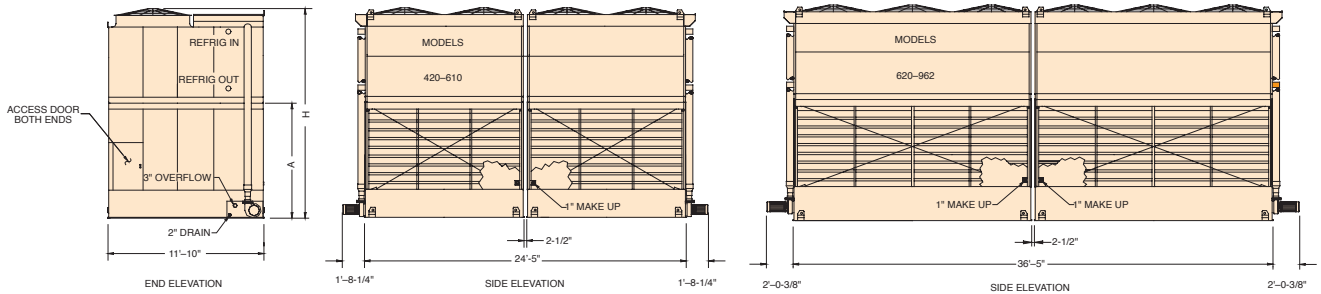

**\* Models CXV-420 to CXV-610 are four fan units, as shown. Models CXV-620 to CXV-962 are six fan units.**

Nom. Box Size	Model Number <sup>1</sup>	Base Heat Rejection (MBH)	R-22 Tons <sup>2</sup>	Fan Motor (HP)	Airflow Rate (CFM)	Pump Motor (HP)	Approx. Weights (lbs)			Ammonia Operating Charge (lbs) <sup>5</sup>	Internal Coil Volume (ft <sup>3</sup> )	Spray Flowrate (GPM)	Remote Sump			L	H	P
							Ship.	Heaviest Section <sup>3</sup>	Oper.				Drain Size (in)	Volume Required (gal)	Approx. Oper. Wt. (lbs)			
12' x 24'	CXV-420	8,705	532	(2) 15	155,800	(2) 5	21,580	6,630	35,060	328	39	1,430	(2) 10"	1,200	33,940	24'-5"	15'-10 3/4"	1'-8 1/4"
	CXV-470	9,742	595	(2) 10	134,400	(2) 5	23,560	7,620	37,340	434	51	1,430	(2) 10"	1,200	36,220	24'-5"	15'-10 3/4"	1'-8 1/4"
	CXV-506	10,488	641	(2) 15	153,600	(2) 5	23,660	7,670	37,440	434	51	1,430	(2) 10"	1,200	36,320	24'-5"	15'-10 3/4"	1'-8 1/4"
	CXV-528	10,944	668	(2) 10	129,860	(2) 5	25,660	8,670	39,740	540	64	1,430	(2) 10"	1,200	38,620	24'-5"	15'-10 3/4"	1'-8 1/4"
	CXV-566	11,731	716	(2) 15	148,400	(2) 5	25,760	8,720	39,840	540	64	1,430	(2) 10"	1,200	38,720	24'-5"	15'-10 3/4"	1'-8 1/4"
	CXV-580	12,022	734	(2) 15	145,400	(2) 5	27,840	9,760	42,220	642	76	1,430	(2) 10"	1,200	41,100	24'-5"	15'-10 3/4"	1'-8 1/4"
	CXV-610	12,643	772	(2) 20	159,900	(2) 5	27,940	9,810	42,320	642	76	1,430	(2) 10"	1,200	41,200	24'-5"	15'-10 3/4"	1'-8 1/4"
12' x 36'	CXV-620	12,851	785	(2)15/(2)7.5	235,800	(2) 7.5	30,640	9,500	51,000	486	58	1,800	(2) 10"	1,500	49,880	36'-5"	16'-4 1/4"	2'-0 3/8"
	CXV-648	13,431	820	(2)20/(2)10	259,300	(2) 7.5	30,820	9,590	51,180	486	58	1,800	(2) 10"	1,500	50,060	36'-5"	16'-4 1/4"	2'-0 3/8"
	CXV-674	13,970	853	(2)25/(2)15	279,100	(2) 7.5	31,020	9,690	51,380	486	58	1,800	(2) 10"	1,500	50,260	36'-5"	16'-4 1/4"	2'-0 3/8"
	CXV-698	14,467	884	(2)10/(2)5	203,520	(2) 7.5	33,600	11,000	54,400	642	77	1,800	(2) 10"	1,500	53,280	36'-5"	16'-4 1/4"	2'-0 3/8"
	CXV-746	15,462	944	(2)15/(2)7.5	232,600	(2) 7.5	33,780	11,070	54,580	642	77	1,800	(2) 10"	1,500	53,460	36'-5"	16'-4 1/4"	2'-0 3/8"
	CXV-776	16,084	982	(2)10/(2)5	196,620	(2) 7.5	36,780	12,590	58,040	802	96	1,800	(2) 10"	1,500	56,920	36'-5"	16'-4 1/4"	2'-0 3/8"
	CXV-796	16,499	1,008	(2)10/(2)5	192,580	(2) 7.5	39,980	14,180	61,660	950	115	1,800	(2) 10"	1,500	60,540	36'-5"	16'-4 1/4"	2'-0 3/8"
	CXV-832	17,245	1,053	(2)15/(2)7.5	224,700	(2) 7.5	36,960	12,660	58,220	802	96	1,800	(2) 10"	1,500	57,100	36'-5"	16'-4 1/4"	2'-0 3/8"
	CXV-854	17,701	1,081	(2)15/(2)7.5	220,100	(2) 7.5	40,140	14,250	61,820	950	115	1,800	(2) 10"	1,500	60,700	36'-5"	16'-4 1/4"	2'-0 3/8"
	CXV-898	18,613	1,137	(2)20/(2)10	242,100	(2) 7.5	40,300	14,330	61,980	950	115	1,800	(2) 10"	1,500	60,860	36'-5"	16'-4 1/4"	2'-0 3/8"
	CXV-932	19,318	1,180	(2)25/(2)15	260,600	(2) 7.5	40,520	14,440	62,200	950	115	1,800	(2) 10"	1,500	61,080	36'-5"	16'-4 1/4"	2'-0 3/8"
	CXV-962	19,939	1,218	(2)30/(2)15	276,700	(2) 7.5	40,560	14,460	62,240	950	115	1,800	(2) 10"	1,500	61,120	36'-5"	16'-4 1/4"	2'-0 3/8"

**Notes:**

- Model number denotes nominal ammonia capacity in evaporator tons at a 96.3°F condensing temperature, a 20°F suction temperature, and a 78°F wet-bulb temperature.
- R-22 tons are at a 105°F condensing temperature, a 40°F suction temperature, and a 78°F wet-bulb temperature.
- Operating weight is for the unit with the water level in the cold water basin at the overflow.
- For R-22 and R-134a, the coil connection quantity will double (except for the CXV-64 thru -153).
- The R-22 operating charge is 1.93 times the ammonia charge; R-134a is 1.98 times.
- Inlet and outlet connections are beveled for welding.
- Standard make-up, drain and overflow connections are MPT.



# Models CXV-N465 to N687

**Do not use for construction.** Refer to factory certified dimensions. This handbook includes data current at the time of publication, which should be reconfirmed at the time of purchase. Up-to-date engineering data, free product selection software and more can be found at [www.BaltimoreAircoil.com](http://www.BaltimoreAircoil.com).



Refrigeration

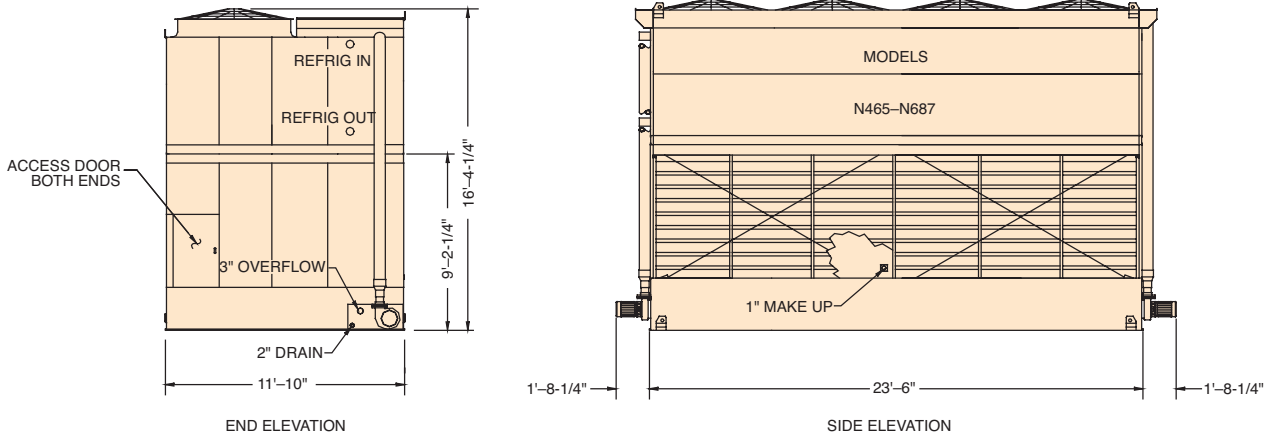

**Designed to minimize refrigerant piping, these models have coil connections on just one end.**

Nom. Box Size	Model Number <sup>1</sup>	Base Heat Rejection (MBH)	R-22 Tons <sup>2</sup>	Fan Motor (HP)	Airflow Rate (CFM)	Pump Motor (HP)	Approx. Weights (lbs)			Ammonia Operating Charge (lbs) <sup>5</sup>	Internal Coil Volume (ft <sup>3</sup> )	Spray Flowrate (GPM)	Remote Sump		
							Ship.	Heaviest Section	Oper. <sup>3</sup>				Drain Size (in)	Volume Required (gal)	Approx. Oper. Wt. (lbs)
12' x 24'	CXV-N465	9,638	589	(2) 15	174,270	(2) 5	20,890	12,750	34,400	323	39	1,430	12"	1,140	33,280
	CXV-N491	10,177	622	(2) 10	149,230	(2) 5	22,780	14,640	36,590	427	51	1,430	12"	1,140	35,470
	CXV-N530	10,985	671	(2) 15	170,810	(2) 5	22,920	14,780	36,730	427	51	1,430	12"	1,140	35,610
	CXV-N559	11,586	708	(2) 20	188,430	(2) 5	22,960	14,820	36,770	427	51	1,430	12"	1,140	35,650
	CXV-N574	11,897	727	(2) 15	169,210	(2) 5	25,000	16,860	39,110	532	63	1,430	12"	1,140	37,990
	CXV-N605	12,540	766	(2) 20	186,220	(2) 5	25,040	16,900	39,150	532	63	1,430	12"	1,140	38,030
	CXV-N636	13,182	805	(2) 20	183,020	(2) 5	27,120	18,980	41,510	631	76	1,430	12"	1,140	40,390
	CXV-N664	13,763	841	(2) 25	197,790	(2) 5	27,220	19,080	41,610	631	76	1,430	12"	1,140	40,490
	CXV-N687	14,239	870	(2) 30	210,170	(2) 5	27,500	19,360	41,890	631	76	1,430	12"	1,140	40,770

**Notes:**

- Model number denotes nominal ammonia capacity in evaporator tons at a 96.3°F condensing temperature, a 20°F suction temperature, and a 78°F wet-bulb temperature.
- R-22 tons are at a 105°F condensing temperature, a 40°F suction temperature, and a 78°F wet-bulb temperature.
- Operating weight is for the unit with the water level in the cold water basin at the overflow.
- For R-22 and R-134a, the coil connection quantity will double (except for the CXV-64 thru -153).
- The R-22 operating charge is 1.93 times the ammonia charge; R-134a is 1.98 times.
- Inlet and outlet connections are beveled for welding.
- Standard make-up, drain and overflow connections are MPT.
- The vertical liquid leg height for models CXV-N465 thru CXV-N687 should be at least 12 feet for multiple condenser installations on ammonia applications. Minimum liquid leg height is subject to overall system piping requirements.

*...because temperature matters™*





# Models CXV-T645 to T188

**Do not use for construction.** Refer to factory certified dimensions. This handbook includes data current at the time of publication, which should be reconfirmed at the time of purchase. Up-to-date engineering data, free product selection software and more can be found at [www.BaltimoreAircoil.com](http://www.BaltimoreAircoil.com).

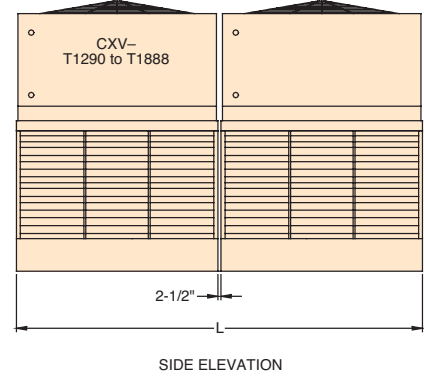
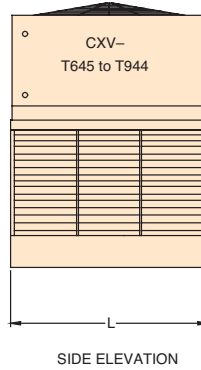
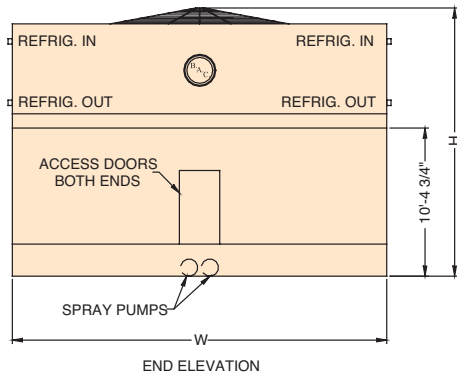

Nom. Box Size	Model Number <sup>1</sup>	Base Heat Rejection (MBH)	R-22 Tons <sup>2</sup>	Fan Motor (HP)	Airflow Rate (CFM)	Pump Motor (HP)	Approx. Weights (lbs)			Ammonia Operating Charge (lbs) <sup>5</sup>	Internal Coil Volume (ft <sup>3</sup> )	Spray Flowrate (GPM)	Remote Sump			"W"	"L"	"H"
							Ship.	Heaviest Section	Oper. <sup>3</sup>				Drain Size (in)	Volume Required (gal)	Approx. Oper. Wt. (lbs)			
12' x 24'	CXV-T645	13,369	816	30	177,100	(2) 7.5	27,710	8,050	42,640	656	76	1,720	12"	1,625	41,240	24'-1/2"	11'-11"	18'-7 7/8"
	CXV-T686	14,219	868	40	195,420	(2) 7.5	27,850	8,050	42,780	656	76	1,720	12"	1,625	41,380	24'-1/2"	11'-11"	18'-7 7/8"
	CXV-T717	14,861	908	50	210,980	(2) 7.5	27,910	8,050	42,840	656	76	1,720	12"	1,625	41,440	24'-1/2"	11'-11"	18'-7 7/8"
	CXV-T729	15,110	923	40	193,150	(2) 7.5	30,610	9,430	45,810	780	91	1,720	12"	1,625	44,410	24'-1/2"	11'-11"	18'-7 7/8"
	CXV-T763	15,815	966	50	208,490	(2) 7.5	30,670	9,430	45,870	780	91	1,720	12"	1,625	44,470	24'-1/2"	11'-11"	18'-7 7/8"
	CXV-T792	16,416	1,003	60	221,910	(2) 7.5	30,830	9,430	46,030	780	91	1,720	12"	1,625	44,630	24'-1/2"	11'-11"	18'-7 7/8"
14' x 26'	CXV-T791	16,395	1,001	40	225,480	(2) 7.5	31,770	9,390	50,070	753	89	1,720	12"	2,000	48,670	26'-3 1/2"	13'-11 1/8"	18'-9 7/8"
	CXV-T827	17,141	1,047	50	245,080	(2) 7.5	31,830	9,390	50,130	753	89	1,720	12"	2,000	48,730	26'-3 1/2"	13'-11 1/8"	18'-9 7/8"
	CXV-T857	17,763	1,085	60	260,910	(2) 7.5	31,990	9,390	50,290	753	89	1,720	12"	2,000	48,890	26'-3 1/2"	13'-11 1/8"	19'-3 7/8"
	CXV-T876	18,157	1,109	50	240,050	(2) 7.5	35,110	11,030	53,740	903	107	1,720	12"	2,000	52,340	26'-3 1/2"	13'-11 1/8"	18'-9 7/8"
	CXV-T906	18,779	1,147	60	255,630	(2) 7.5	35,270	11,030	53,900	903	107	1,720	12"	2,000	52,500	26'-3 1/2"	13'-11 1/8"	19'-3 7/8"
	CXV-T944	19,566	1,195	75	278,020	(2) 7.5	35,320	11,030	53,950	903	107	1,720	12"	2,000	52,550	26'-3 1/2"	13'-11 1/8"	19'-3 7/8"
24' x 24'	CXV-T1290	26,738	1,633	(2) 30	354,200	(4) 7.5	55,420	8,050	85,280	1,312	152	3,440	(2) 12"	3,250	82,480	24'-1/2"	24'-1/2"	18'-7 7/8"
	CXV-T1372	28,437	1,737	(2) 40	390,840	(4) 7.5	55,700	8,050	85,560	1,312	152	3,440	(2) 12"	3,250	82,760	24'-1/2"	24'-1/2"	18'-7 7/8"
	CXV-T1434	29,723	1,815	(2) 50	421,960	(4) 7.5	55,820	8,050	85,680	1,312	152	3,440	(2) 12"	3,250	82,880	24'-1/2"	24'-1/2"	18'-7 7/8"
	CXV-T1458	30,220	1,846	(2) 40	386,300	(4) 7.5	61,220	9,430	91,620	1,560	182	3,440	(2) 12"	3,250	88,820	24'-1/2"	24'-1/2"	18'-7 7/8"
	CXV-T1526	31,629	1,932	(2) 50	416,980	(4) 7.5	61,340	9,430	91,740	1,560	182	3,440	(2) 12"	3,250	88,940	24'-1/2"	24'-1/2"	18'-7 7/8"
	CXV-T1584	32,832	2,005	(2) 60	443,820	(4) 7.5	61,660	9,430	92,060	1,560	182	3,440	(2) 12"	3,250	89,260	24'-1/2"	24'-1/2"	18'-7 7/8"
28' x 26'	CXV-T1582	32,790	2,003	(2) 40	450,960	(4) 7.5	63,540	9,390	100,140	1,506	178	3,440	(2) 12"	4,000	97,340	26'-3 1/2"	28'-3/4"	18'-9 7/8"
	CXV-T1654	34,282	2,094	(2) 50	490,160	(4) 7.5	63,660	9,390	100,260	1,506	178	3,440	(2) 12"	4,000	97,460	26'-3 1/2"	28'-3/4"	18'-9 7/8"
	CXV-T1714	35,526	2,170	(2) 60	521,820	(4) 7.5	63,980	9,390	100,580	1,506	178	3,440	(2) 12"	4,000	97,780	26'-3 1/2"	28'-3/4"	19'-3 7/8"
	CXV-T1752	36,314	2,218	(2) 50	480,100	(4) 7.5	70,220	11,030	107,480	1,806	214	3,440	(2) 12"	4,000	104,680	26'-3 1/2"	28'-3/4"	18'-9 7/8"
	CXV-T1812	37,557	2,294	(2) 60	511,260	(4) 7.5	70,540	11,030	107,800	1,806	214	3,440	(2) 12"	4,000	105,000	26'-3 1/2"	28'-3/4"	19'-3 7/8"
	CXV-T1888	39,133	2,390	(2) 75	556,040	(4) 7.5	70,640	11,030	107,900	1,806	214	3,440	(2) 12"	4,000	105,100	26'-3 1/2"	28'-3/4"	19'-3 7/8"

**Notes:**

- Model number denotes nominal ammonia capacity in evaporator tons at a 96.3°F condensing temperature, a 20°F suction temperature, and a 78°F wet-bulb temperature.
- R-22 tons are at a 105°F condensing temperature, a 40°F suction temperature, and a 78°F wet-bulb temperature.
- Operating weight is for the unit with the water level in the cold water basin at the overflow.
- Coil connections also available on the end. For other refrigerants, contact your local BAC Representative for the coil connection quantity.
- The R-22 operating charge is 1.93 times the ammonia charge; R-134a is 1.98 times.
- Inlet and outlet connections are beveled for welding.
- Standard make-up, drain and overflow connections are located on the bottom of the unit. Make-up connection is 1-1/2" MPT standpipe, drain is 2" FPT and overflow is 3" FPT.
- Models shipped with an optional gear drive or low sound fan may have heights up to 10.5" greater than shown.





# VC2 Models

**Do not use for construction.** Refer to factory certified dimensions. This handbook includes data current at the time of publication, which should be reconfrmed at the time of purchase. Up-to-date engineering data, free product selection software and more can be found at [www.BaltimoreAircoil.com](http://www.BaltimoreAircoil.com).

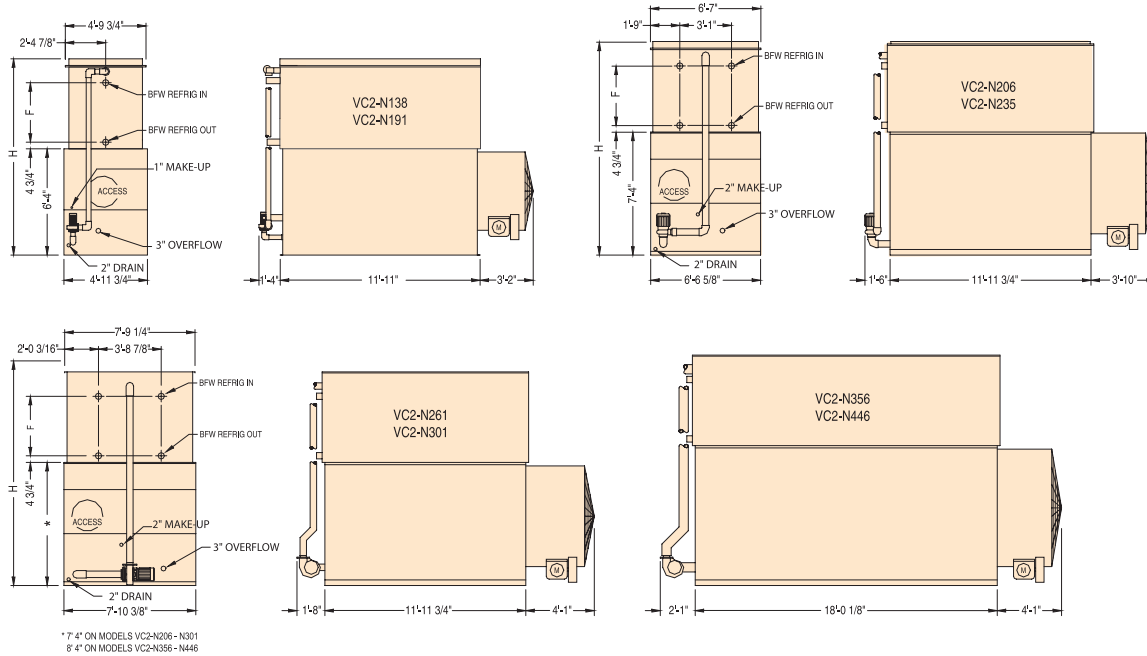

Nom. Box Size	Model Number <sup>1</sup>	Base Heat Rejection (MBH)	R-717 Tons <sup>2</sup>	Approx. Weights (lbs)			CFM	Motor HP (0" ESP)	GPM	Pump Motor HP	R-717 Oper. Charge <sup>6</sup> (lbs.)	Internal Coil Volume (ft <sup>3</sup> )	Remote Sump			F	H
				Ship.	Heaviest Section <sup>4</sup>	Oper. <sup>3</sup>							Drain Size (in)	Approx. Oper. Weight	Gal. Req.		
4.5' x 12'	VC2-N138	2,029	98	7,130	4,920	8,920	25,900	5	220	1 1/2	170	18	6	7,610	270	33 1/4	131 1/8
	VC2-N150	2,205	106	7,220	5,830	9,010	28,300	7 1/2	220	1 1/2	190	18	6	7,700	270	33 1/4	131 1/8
	VC2-N170	2,499	121	8,120	5,930	9,930	28,000	7 1/2	220	1 1/2	210	23	6	86,250	270	42 1/2	140 3/8
	VC2-N191	2,808	135	8,770	6,580	10,580	30,100	10	220	1 1/2	245	27	6	9,270	270	51 3/4	149 5/8
6' x 12'	VC2-N206	3,028	146	9,960	6,580	14,950	39,650	10	305	2	230	25	6	12,690	430	33 1/4	143 1/8
	VC2-N215	3,161	152	11,190	7,810	16,180	35,050	7 1/2	305	2	290	31	6	13,920	430	42 1/2	152 3/4
	VC2-N235	3,455	167	11,210	7,810	16,200	38,750	10	305	2	290	31	6	13,940	430	42 1/2	152 3/4
8' x 12'	VC2-N261	3,837	185	11,860	8,460	15,380	43,400	10	385	3	360	40	8	13,420	480	42 1/2	152 3/4
	VC2-N301	4,425	213	13,310	9,860	16,970	48,550	15	385	3	430	47	8	15,010	480	51 3/4	162
8' x 18'	VC2-N356	5,233	252	15,170	10,390	20,260	67,650	15	580	5	435	48	10	17,250	820	33 1/4	155 1/2
	VC2-N396	5,821	281	17,350	12,570	22,650	65,700	15	580	5	540	59	10	19,640	820	42 1/2	164 3/4
	VC2-N416	6,115	295	19,530	14,750	25,050	64,200	15	580	5	645	71	10	22,040	820	51 3/4	174
	VC2-N446	6,556	316	19,540	14,750	25,060	70,650	20	580	5	645	71	10	22,050	820	51 3/4	174

**Notes:**

- Model number denotes nominal tons using R-22 at a 105°F condensing temperature, a 40°F suction temperature, and a 78°F wet-bulb temperature.
- R-717 tons are at a 96.3°F condensing temperature, a 20°F suction temperature, and a 78°F wet-bulb temperature.
- Operating weight shown is based on total unit weight, weight of refrigerant operating charge, and cold water basin filled to the overflow level.
- Unless otherwise noted, the coil section is the heaviest section.
- Standard refrigerant connection size is 4" BFW (inlet and outlet).
- Refrigerant charge listed is R-717 operating charge. To determine operating charge for R-22, multiply charge by 1.93. For R-134a, multiply by 1.98.

*...because temperature matters™*



# VC2 Models

**Do not use for construction.** Refer to factory certified dimensions. This handbook includes data current at the time of publication, which should be reconfirmed at the time of purchase. Up-to-date engineering data, free product selection software and more can be found at [www.BaltimoreAircoil.com](http://www.BaltimoreAircoil.com).

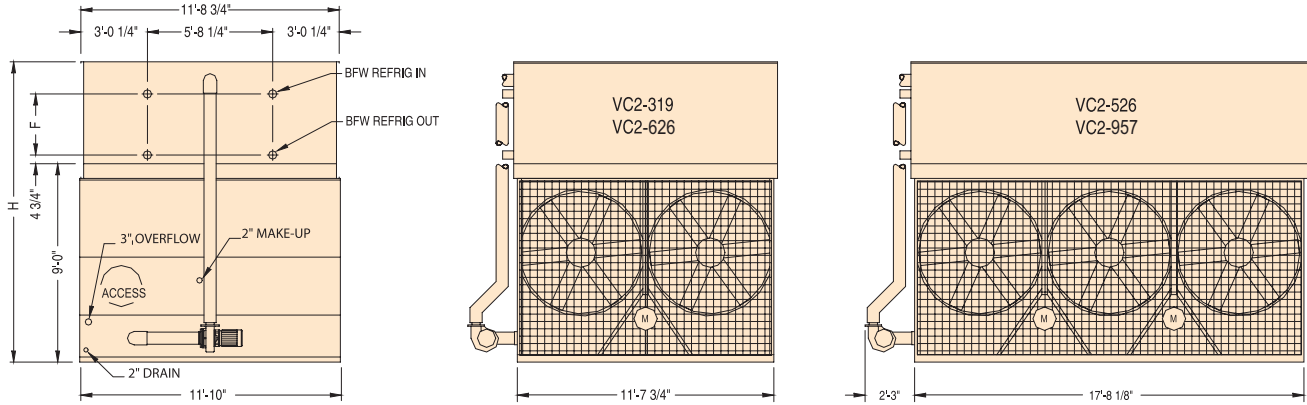

Nom. Box Size	Model Number <sup>1</sup>	Base Heat Rejection (MBH)	R-717 Tons <sup>2</sup>	Approx. Weights (lbs)			CFM	Motor HP (0" ESP)	GPM	Pump Motor HP	R-717 Oper. Charge <sup>6</sup> (lbs.)	Internal Coil Volume (ft <sup>3</sup> )	Remote Sump			F	H
				Ship.	Heaviest Section <sup>4</sup>	Oper <sup>3</sup>							Drain Size (in)	Approx. Oper. Weight	Gal. Req.		
12' x 12'	VC2-319	4,689	226	15,240	10,300	24,590	54,300	7.5	585	5	445	49	8	19,550	480	33 1/4	163 1/2
	VC2-342	5,027	243	15,290	10,300	24,640	59,750	10	585	5	445	49	8	19,600	480	33 1/4	163 1/2
	VC2-377	5,542	267	15,340	10,300	24,690	68,400	15	585	5	445	49	8	19,650	480	33 1/4	163 1/2
	VC2-420	6,174	298	17,410	12,370	26,970	68,400	15	585	5	550	60	8	21,930	480	42 1/2	172 3/4
	VC2-451	6,630	320	17,420	12,370	26,980	73,100	20	585	5	550	60	8	21,940	480	42 1/2	172 3/4
	VC2-471	6,924	334	19,450	14,400	29,010	71,400	20	585	5	675	72	8	23,970	480	51 3/4	182
	VC2-491	7,218	348	19,470	14,400	29,030	76,950	25	585	5	675	72	8	23,990	480	51 3/4	182
	VC2-513	7,541	364	19,490	14,400	29,050	81,750	30	585	5	675	72	8	24,010	480	51 3/4	182
	VC2-541	7,953	384	20,870	15,780	30,510	81,500	30	585	5	750	80	8	25,470	480	51 3/4	182
	VC2-580	8,526	411	21,060	15,780	30,700	89,700	40	585	5	750	80	8	25,660	480	51 3/4	182
	VC2-585	8,600	415	22,740	18,205	33,445	77,040	30	585	5	875	93	8	28,405	480	61	194 1/4
VC2-626	9,202	444	22,795	18,205	33,500	85,200	40	585	5	875	93	8	28,460	480	61	194 1/4	
12' x 18'	VC2-526	7,732	373	22,220	15,170	36,430	89,700	10 & 5	835	5	665	73	10	29,050	670	33 1/4	163 1/2
	VC2-581	8,541	412	22,330	15,170	36,540	102,650	15 & 7.5	835	5	665	73	10	29,160	670	33 1/4	163 1/2
	VC2-623	9,158	442	22,350	15,170	36,560	113,000	20 & 10	835	5	665	73	10	29,180	670	33 1/4	163 1/2
	VC2-642	9,437	455	25,450	18,290	39,990	99,600	15 & 7.5	835	5	825	90	10	32,610	670	42 1/2	172 3/4
	VC2-688	10,114	488	25,470	18,290	40,010	109,650	20 & 10	835	5	825	90	10	32,630	670	42 1/2	172 3/4
	VC2-711	10,452	504	28,580	21,400	43,450	107,150	20 & 10	835	5	990	108	10	36,070	670	51 3/4	182
	VC2-752	11,054	533	28,680	21,400	43,550	115,400	25 & 15	835	5	990	108	10	36,170	670	51 3/4	182
	VC2-785	11,540	557	28,700	21,400	43,570	122,650	30 & 15	835	5	990	108	10	36,190	670	51 3/4	182
	VC2-827	12,157	587	30,780	23,480	45,760	122,200	30 & 15	835	5	1,100	120	10	38,380	670	51 3/4	182
	VC2-887	13,039	629	30,980	23,480	45,960	134,500	40 & 20	835	5	1,100	120	10	38,580	670	51 3/4	182
	VC2-895	13,157	635	33,655	27,160	49,895	115,000	30 & 15	900	7.5	1,290	140	10	42,515	670	61	194 1/4
	VC2-957	14,068	679	33,765	27,160	50,005	126,080	40 & 20	900	7.5	1,290	140	10	42,625	670	61	194 1/4

**Notes:**

- Model number denotes nominal tons using R-22 at a 105°F condensing temperature, a 40°F suction temperature, and a 78°F wet-bulb temperature.
- R-717 tons are at a 96.3°F condensing temperature, a 20°F suction temperature, and a 78°F wet-bulb temperature.
- Operating weight shown is based on total unit weight, weight of refrigerant operating charge, and cold water basin filled to the overflow level.
- Unless otherwise noted, the coil section is the heaviest section.
- Standard refrigerant connection size is 4" BFW (inlet and outlet).
- Refrigerant charge listed is R-717 operating charge. To determine operating charge for R-22, multiply charge by 1.93. For R-134a, multiply by 1.98.



# VC2 Models

**Do not use for construction.** Refer to factory certified dimensions. This handbook includes data current at the time of publication, which should be reconfirmed at the time of purchase. Up-to-date engineering data, free product selection software and more can be found at [www.BaltimoreAircoil.com](http://www.BaltimoreAircoil.com).



Refrigeration

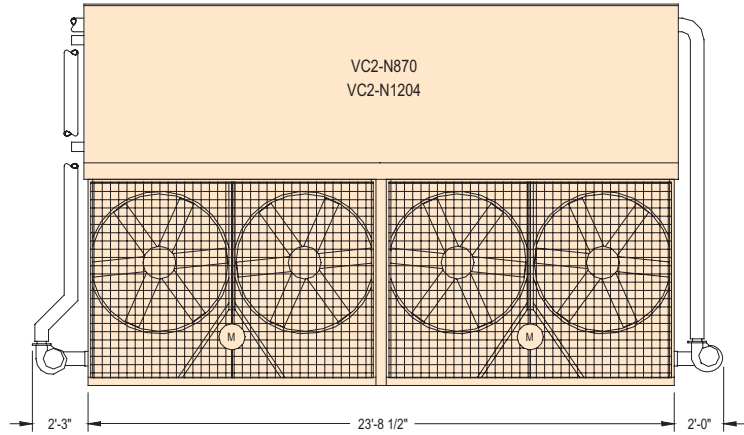
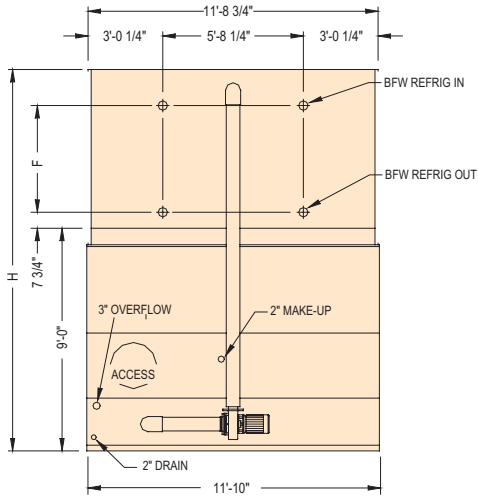

Nom. Box Size	Model Number <sup>1</sup>	Base Heat Rejection (MBH)	R-717 Tons <sup>2</sup>	Approx. Weights (lbs)			CFM	Motor HP (0" ESP)	GPM	Pump Motor HP	R-717 Oper. Charge <sup>6</sup> (lbs.)	Internal Coil Volume (ft <sup>3</sup> )	Remote Sump			F	H
				Ship.	Heaviest Section <sup>4</sup>	Oper. <sup>3</sup>							Drain Size	Approx. Oper. Weight	Gal. Req.		
12' x 24'	VC2-N870	12,789	617	32,325	23,855	53,195	132,800	(2) 15	1,170	(2) 5	1,100	112	10	42,935	1,440	42 1/2	175 3/4
	VC2-N932	13,700	661	32,415	23,855	53,285	146,200	(2) 20	1,170	(2) 5	1,100	112	10	43,025	1,440	42 1/2	175 3/4
	VC2-N1000	14,700	709	32,725	23,855	53,595	163,100	(2) 25	1,170	(2) 5	1,350	112	10	43,335	1,440	42 1/2	175 3/4
	VC2-N1071	15,744	760	38,595	27,795	58,445	163,500	(2) 30	1,170	(2) 5	1,350	136	10	48,185	1,440	51 3/4	185
	VC2-N1124	16,523	797	39,610	30,510	61,480	160,230	(2) 30	1,170	(2) 5	1,510	150	10	51,700	1,440	51 3/4	185
	VC2-N1204	17,699	854	39,740	30,510	61,610	176,340	(2) 40	1,170	(2) 5	1,510	150	10	52,080	1,440	51 3/4	185

**Notes:**

- Model number denotes nominal tons using R-22 at a 105°F condensing temperature, a 40°F suction temperature, and a 78°F wet-bulb temperature.
- R-717 tons are at a 96.3°F condensing temperature, a 20°F suction temperature, and a 78°F wet-bulb temperature.
- Operating weight shown is based on total unit weight, weight of refrigerant operating charge, and cold water basin filled to the overflow level.
- Unless otherwise noted, the coil section is the heaviest section.
- Standard refrigerant connection size is 4" BFW (inlet and outlet).
- Refrigerant charge listed is R-717 operating charge. To determine operating charge for R-22, multiply charge by 1.93. For R-134a, multiply by 1.98.

*...because temperature matters™*





# VC2 Models

**Do not use for construction.** Refer to factory certified dimensions. This handbook includes data current at the time of publication, which should be reconfirmed at the time of purchase. Up-to-date engineering data, free product selection software and more can be found at [www.BaltimoreAircoil.com](http://www.BaltimoreAircoil.com).

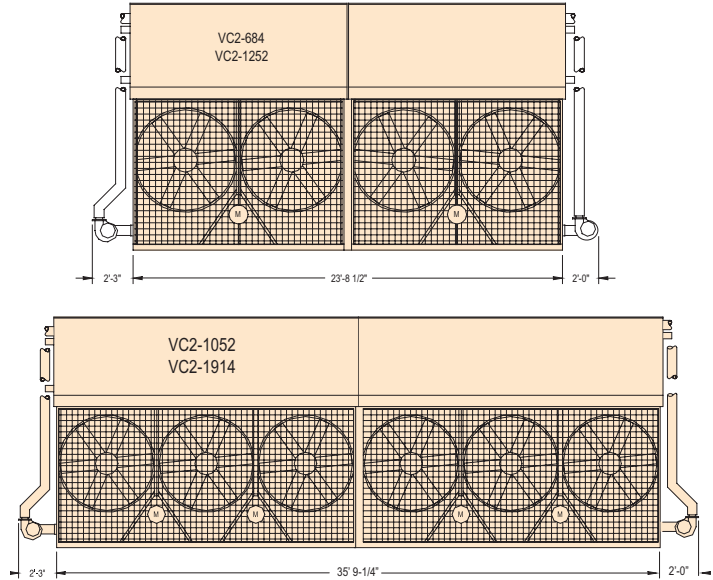
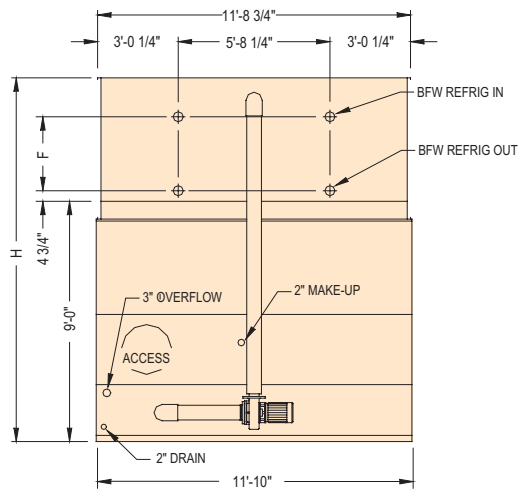

Nom. Box Size	Model Number <sup>1</sup>	Base Heat Rejection (MBH)	R-717 Tons <sup>2</sup>	Approx. Weights (lbs)			CFM	Motor HP (0" ESP)	GPM	Pump Motor HP	R-717 Oper. Charge <sup>6</sup> (lbs.)	Internal Coil Volume (ft <sup>3</sup> )	Remote Sump			F	H
				Ship.	Heaviest Section <sup>4</sup>	Oper. <sup>3</sup>							Drain Size (in)	Approx. Oper. Weight	Gal. Req.		
12' x 24'	VC2-684	10,055	485	30,570	10,300	49,580	119,500	(2) 10	1,170	(2) 5	890	98	10	39,320	1,440	33 1/4	163 1/2
	VC2-754	11,084	535	30,670	10,300	49,680	136,800	(2) 15	1,170	(2) 5	890	98	10	39,420	1,440	33 1/4	163 1/2
	VC2-840	12,348	596	34,810	12,370	54,240	132,800	(2) 15	1,170	(2) 5	1,100	121	10	43,980	1,440	42 1/2	172 3/4
	VC2-902	13,259	640	34,830	12,370	54,260	146,200	(2) 20	1,170	(2) 5	1,100	121	10	44,000	1,440	42 1/2	172 3/4
	VC2-942	13,847	668	38,900	14,400	58,020	142,800	(2) 20	1,170	(2) 5	1,350	144	10	47,760	1,440	51 3/4	182
	VC2-982	14,435	696	38,940	14,400	58,060	153,900	(2) 25	1,170	(2) 5	1,350	144	10	47,780	1,440	51 3/4	182
	VC2-1026	15,082	728	38,980	14,400	58,100	163,500	(2) 30	1,170	(2) 5	1,350	144	10	47,820	1,440	51 3/4	182
	VC2-1082	15,905	767	41,740	15,780	61,020	160,230	(2) 30	1,170	(2) 5	1,510	160	10	50,740	1,440	51 3/4	182
	VC2-1160	17,052	823	42,120	15,780	61,400	176,340	(2) 40	1,170	(2) 5	1,510	160	10	51,120	1,440	51 3/4	182
	VC2-1170	17,199	830	45,905	15,780	67,645	154,080	(2) 30	1,170	(2) 5	1,715	186	10	57,385	1,440	61	194 1/4
	VC2-1252	18,404	888	46,015	15,780	67,755	170,400	(2) 40	1,170	(2) 5	1,715	186	10	57,495	1,440	61	194 1/4
	12' x 36'	VC2-1052	15,464	746	44,420	15,170	73,170	179,400	(2) 10 & (2) 5	1,670	(2) 5	1,330	146	12	58,240	2,220	33 1/4
VC2-1162		17,081	824	44,640	15,170	73,390	205,300	(2) 15 & (2) 7 1/2	1,670	(2) 5	1,330	146	12	58,460	2,220	33 1/4	163 1/2
VC2-1246		18,316	884	44,680	15,170	73,430	226,000	(2) 20 & (2) 10	1,670	(2) 5	1,330	146	12	58,500	2,220	33 1/4	163 1/2
VC2-1284		18,875	911	50,880	18,290	80,290	199,200	(2) 15 & (2) 7 1/2	1,670	(2) 5	1,650	181	12	65,360	2,220	42 1/2	172 3/4
VC2-1376		20,227	976	50,920	18,290	80,330	219,300	(2) 20 & (2) 10	1,670	(2) 5	1,650	181	12	65,400	2,220	42 1/2	172 3/4
VC2-1422		20,903	1,009	57,140	21,400	87,210	214,300	(2) 20 & (2) 10	1,670	(2) 5	1,980	216	12	72,280	2,220	51 3/4	182
VC2-1504		22,109	1,067	57,340	21,400	87,410	230,800	(2) 25 & (2) 15	1,670	(2) 5	1,980	216	12	72,480	2,220	51 3/4	182
VC2-1570		23,079	1,113	57,380	21,400	87,450	245,300	(2) 30 & (2) 15	1,670	(2) 5	1,980	216	12	72,520	2,220	51 3/4	182
VC2-1654		24,314	1,173	61,540	23,480	91,840	240,400	(2) 30 & (2) 15	1,670	(2) 5	2,210	241	12	76,910	2,220	51 3/4	182
VC2-1774		26,078	1,258	61,940	23,480	92,240	264,600	(2) 40 & (2) 20	1,670	(2) 5	2,210	241	12	77,310	2,220	51 3/4	182
VC2-1790		26,313	1,269	67,000	27,160	99,790	230,000	(2) 30 & (2) 15	1,800	(2) 7.5	2,580	280	12	84,860	2,220	61	194 1/4
VC2-1914		28,136	1,357	67,220	27,160	100,010	252,160	(2) 40 & (2) 20	1,800	(2) 7.5	2,580	280	12	85,080	2,220	61	194 1/4

**Notes:**

- Model number denotes nominal tons using R-22 at a 105°F condensing temperature, a 40°F suction temperature, and a 78°F wet-bulb temperature.
- R-717 tons are at a 96.3°F condensing temperature, a 20°F suction temperature, and a 78°F wet-bulb temperature.
- Operating weight shown is based on total unit weight, weight of refrigerant operating charge, and cold water basin filled to the overflow level.
- Unless otherwise noted, the coil section is the heaviest section.
- Standard refrigerant connection size is 4" BFW (inlet and outlet).
- Refrigerant charge listed is R-717 operating charge. To determine operating charge for R-22, multiply charge by 1.93. For R-134a, multiply by 1.98.



# VXMC Models

**Do not use for construction.** Refer to factory certified dimensions. This handbook includes data current at the time of publication, which should be reconfirmed at the time of purchase. Up-to-date engineering data, free product selection software and more can be found at [www.BaltimoreAircoil.com](http://www.BaltimoreAircoil.com).



Refrigeration

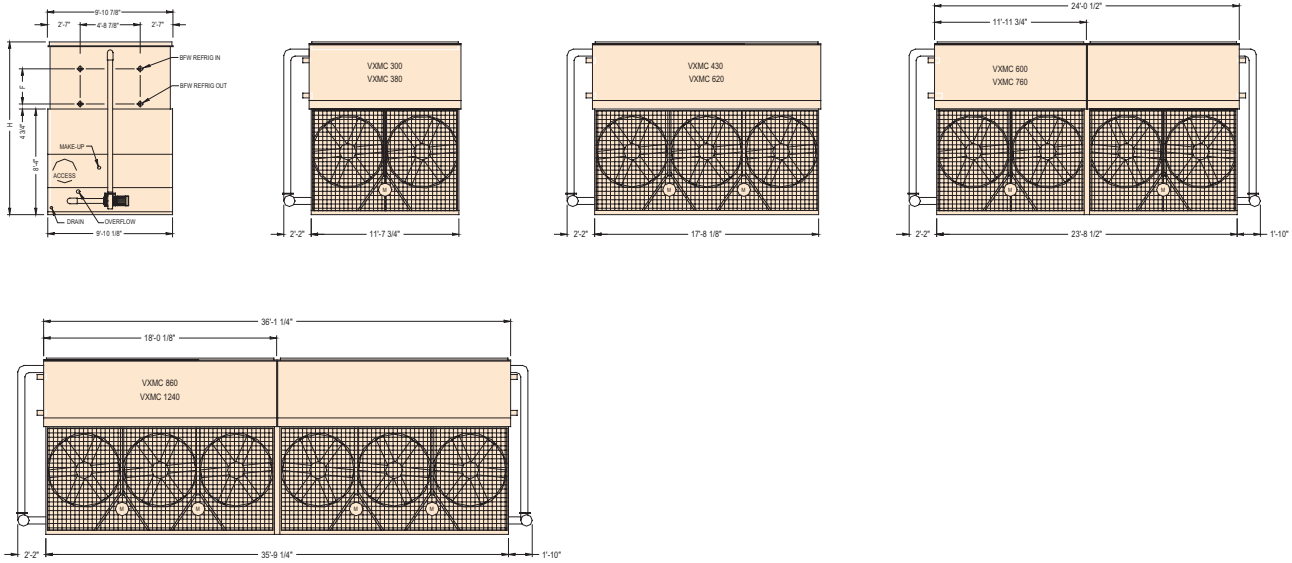

Nom. Box Size	Model Number <sup>1</sup>	Base Heat Rejection (MBH)	R-717 Tons <sup>2</sup>	Approx. Weights (lbs)			CFM	Motor HP (0" ESP)	GPM	Pump Motor HP	R-717 Oper. Charge <sup>6</sup> (lbs.)	Internal Coil Volume (ft <sup>3</sup> )	Remote Sump			F	H
				Ship.	Heaviest Section <sup>4</sup>	Oper. <sup>3</sup>							Drain Size (in)	Approx. Oper. Weight	Gal. Req.		
10' x 12'	VXMC-300	4,410	213	14,420	9,760	18,950	59,800	10	490	5	380	40	8	15680	213	37 3/4	157 7/8
	VXMC-340	4,998	241	16,280	11,580	20,900	55,400	10	490	5	460	50	8	17630	213	48 1/4	168 3/8
	VXMC-380	5,586	270	18,180	13,400	22,870	59,400	15	490	5	550	59	8	19600	213	58 3/4	178 7/8
10' x 18'	VXMC-430	6,321	305	20,370	14,750	27,120	80,700	5/7.5	740	5	560	60	10	22600	323	37 3/4	157 7/8
	VXMC-460	6,762	326	22,920	15,010	27,360	87,700	5/10	740	5	590	60	10	22840	323	37 3/4	157 7/8
	VXMC-510	7,497	362	23,080	17,430	29,960	87,200	5/10	740	5	700	75	10	25440	323	48 1/4	168 3/8
	VXMC-560	8,232	397	23,360	17,710	30,220	95,700	7.5/15	740	5	750	75	10	25700	323	48 1/4	168 3/4
	VXMC-585	8,600	415	25,980	20,230	32,970	93,600	7.5/15	740	5	830	89	10	28460	323	58 3/4	178 7/8
	VXMC-620	9,114	440	26,280	20,530	33,250	100,500	10/20	740	5	860	89	10	28740	323	58 3/4	178 7/8
10' x 24'	VXMC-600	8,820	426	28,840	9,760	37,900	119,600	(2) 10	980	(2) 5	760	80	10	31360	433	37 3/4	157 7/8
	VXMC-680	9,996	482	32,560	11,580	41,800	110,800	(2) 10	980	(2) 5	920	99	10	35260	433	48 1/4	168 3/4
	VXMC-760	11,172	539	36,360	13,400	45,740	118,800	(2) 15	980	(2) 5	1100	118	10	39200	433	58 3/4	178 7/8
10' x 36'	VXMC-860	12,642	610	44,740	15,240*	54,240	161,400	(2)5/(2)7.5	1480	(2) 5	1120	120	12	45200	654	37 3/4	157 7/8
	VXMC-920	13,524	652	45,840	15,820*	54,720	175,400	(2)5/(2)10	1480	(2) 5	1180	120	12	45680	654	37 3/4	157 7/8
	VXMC-1020	14,994	723	46,160	17,430	59,920	174,400	(2)5/(2)10	1480	(2) 5	1400	149	12	50880	654	48 1/4	168 3/8
	VXMC-1120	16,464	794	46,720	17,710	60,440	191,400	(2)7.5/(2)15	1480	(2) 5	1500	149	12	51400	654	48 1/4	168 3/8
	VXMC-1170	17,199	830	51,960	20,230	65,940	187,200	(2)7.5/(2)15	1480	(2) 5	1660	178	12	56920	654	58 3/4	178 7/8
	VXMC-1240	18,228	879	52,560	20,530	66,500	201,000	(2)10/(2)20	1480	(2) 5	1720	178	12	57480	654	58 3/4	178 7/8

**Notes:**

- Model number denotes nominal tons using R-22 at a 105°F condensing temperature, a 40°F suction temperature, and a 78°F wet-bulb temperature.
- R-717 tons are at a 96.3°F condensing temperature, a 20°F suction temperature, and a 78°F wet-bulb temperature.
- Operating weight shown is based on total unit weight, weight of refrigerant operating charge, and cold water basin filled to the overflow level.
- Unless otherwise noted, the coil section is the heaviest section.
- Standard refrigerant connection size is 4" BFW (inlet and outlet).
- Refrigerant charge listed is R-717 operating charge. To determine operating charge for R-22, multiply charge by 1.93. For R-134a, multiply by 1.98.

...because temperature matters™



# VC1 Models

**Do not use for construction.** Refer to factory certified dimensions. This handbook includes data current at the time of publication, which should be reconfirmed at the time of purchase. Up-to-date engineering data, free product selection software and more can be found at [www.BaltimoreAircoil.com](http://www.BaltimoreAircoil.com).

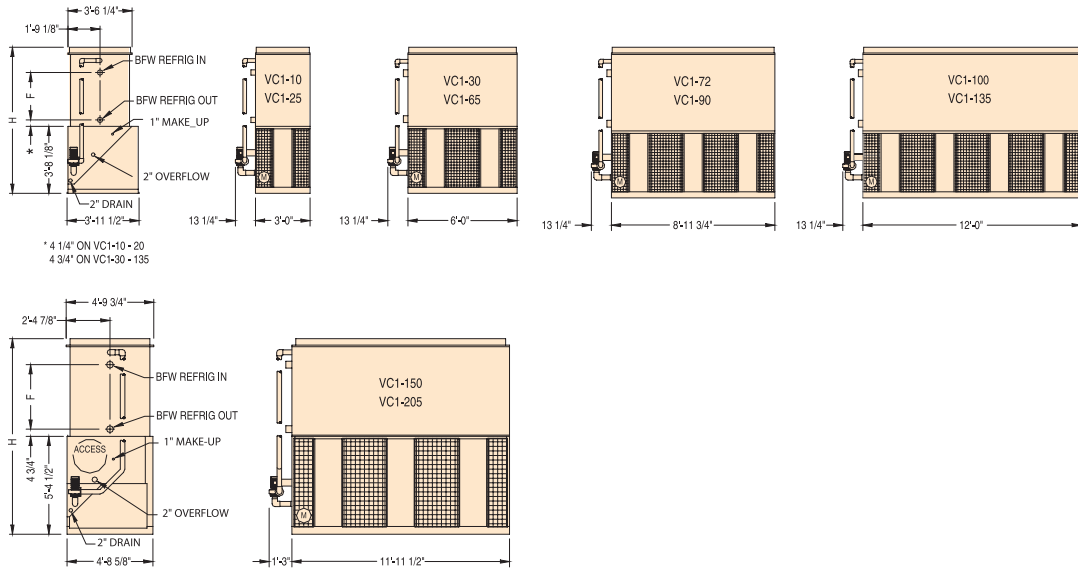

Nom. Box Size	Model Number <sup>1</sup>	Base Heat Rejection (MBH)	R-717 Tons <sup>2</sup>	Approx. Weights (lbs)				Motor HP <sup>3</sup> (0" ESP)	Pump Motor HP	R-717 Oper. Charge <sup>7</sup> (lbs.)	Internal Coil Volume (ft <sup>3</sup> )	Remote Sump			F	H	
				Ship.	Heaviest Section <sup>5</sup>	Oper. <sup>4</sup>	CFM					Drain Size (in)	Approx. Oper. Weight	Gal. Req.			
3' x 3'	VC1-10	147	7	1,270	* 1,270	1,400	2,900	1/2	35	1/3	19	2	2 1/2	1,220	25	14 1/4	79 1/4
	VC1-15	221	11	1,460	* 1,460	1,600	3,800	1	35	1/3	25	2.7	2 1/2	1,420	25	22 3/4	87 3/4
	VC1-20	294	14	1,620	1,000	1,770	4,400	1 1/2	35	1/3	32	3.5	2 1/2	1,590	25	31 1/4	96 1/4
	VC1-25	368	18	1,670	1,050	1,820	5,300	3	35	1/3	34	3.5	2 1/2	1,640	25	31 1/4	96 1/4
3' x 6'	VC1-30	441	21	2,010	* 2,010	2,300	8,200	3	75	1/2	35	3.5	3	1,990	50	13 1/4	79 1/4
	VC1-38	559	27	2,240	* 2,240	2,560	8,900	3	75	1/2	45	5.0	3	2,250	50	21 3/4	87 3/4
	VC1-46	676	33	2,540	1,650	2,880	8,500	3	75	1/2	61	6.5	3	2,570	50	30 1/4	96 1/4
	VC1-52	764	37	2,590	1,700	2,930	10,200	5	75	1/2	65	6.5	3	2,620	50	30 1/4	96 1/4
	VC1-58	853	41	2,860	1,940	3,230	9,800	5	75	1/2	76	8.0	3	2,920	50	38 3/4	104 3/4
	VC1-65	956	46	2,930	2,010	3,300	11,600	7 1/2	75	1/2	80	8.0	3	2,990	50	38 3/4	104 3/4
3' x 9'	VC1-72	1,058	51	3,510	2,400	4,210	12,300	5	115	3/4	90	9.6	4	3,770	75	33 1/4	99 1/4
	VC1-80	1,176	57	3,580	2,470	4,280	14,500	7 1/2	115	3/4	100	9.6	4	3,840	75	33 1/4	99 1/4
	VC1-90	1,323	64	4,000	2,850	4,750	14,000	7 1/2	115	3/4	110	12	4	4,310	75	42 1/2	108 1/2
3' x 12'	VC1-100	1,470	71	4,450	3,060	5,420	19,600	7 1/2	150	1	120	13	4	4,830	105	33 1/4	99 1/4
	VC1-110	1,617	78	4,530	3,140	5,500	22,000	10	150	1	130	13	4	4,910	105	33 1/4	99 1/4
	VC1-125	1,838	89	5,060	3,640	6,080	21,000	10	150	1	145	16	4	5,490	105	42 1/2	108 1/2
	VC1-135	1,985	96	5,180	3,640	6,160	23,000	15	150	1	145	16	4	5,570	105	42 1/2	108 1/2
4.5' x 12'	VC1-150	2,205	106	7,480	4,920	8,730	28,200	10	220	1 1/2	170	18	6	7,880	140	33 1/4	119 5/8
	VC1-165	2,426	117	8,060	5,830	9,680	27,200	10	220	1 1/2	210	23	6	8,830	140	42 1/2	128 7/8
	VC1-185	2,720	131	8,170	5,930	9,770	33,300	15	220	1 1/2	210	23	6	8,920	140	42 1/2	128 7/8
	VC1-205	3,014	145	8,820	6,580	10,420	35,800	20	220	1 1/2	245	27	6	9,570	140	51 3/4	138 1/8

**Notes:**

- Model number denotes nominal tons using R-22 at a 105°F condensing temperature, a 40°F suction temperature, and a 78°F wet-bulb temperature.
- R-717 tons are at a 96.3°F condensing temperature, a 20°F suction temperature, and a 78°F wet-bulb temperature.
- Fan horsepower is at 0" external static pressure.
- Operating weight shown is based on total unit weight, weight of refrigerant operating charge, and cold water basin filled to the overflow level.
- Unless otherwise noted, the coil section is the heaviest section.
- Standard refrigerant connection sizes are 3" BFW inlet and outlet for VC1-10 through -25, and 4" BFW inlet and outlet for all other models.
- Refrigerant charge listed is R-717 operating charge. To determine operating charge for R-22, multiply charge by 1.93. For R-134a, multiply by 1.98.





# VC1 Models

**Do not use for construction.** Refer to factory certified dimensions. This handbook includes data current at the time of publication, which should be reconformed at the time of purchase. Up-to-date engineering data, free product selection software and more can be found at [www.BaltimoreAircoil.com](http://www.BaltimoreAircoil.com).

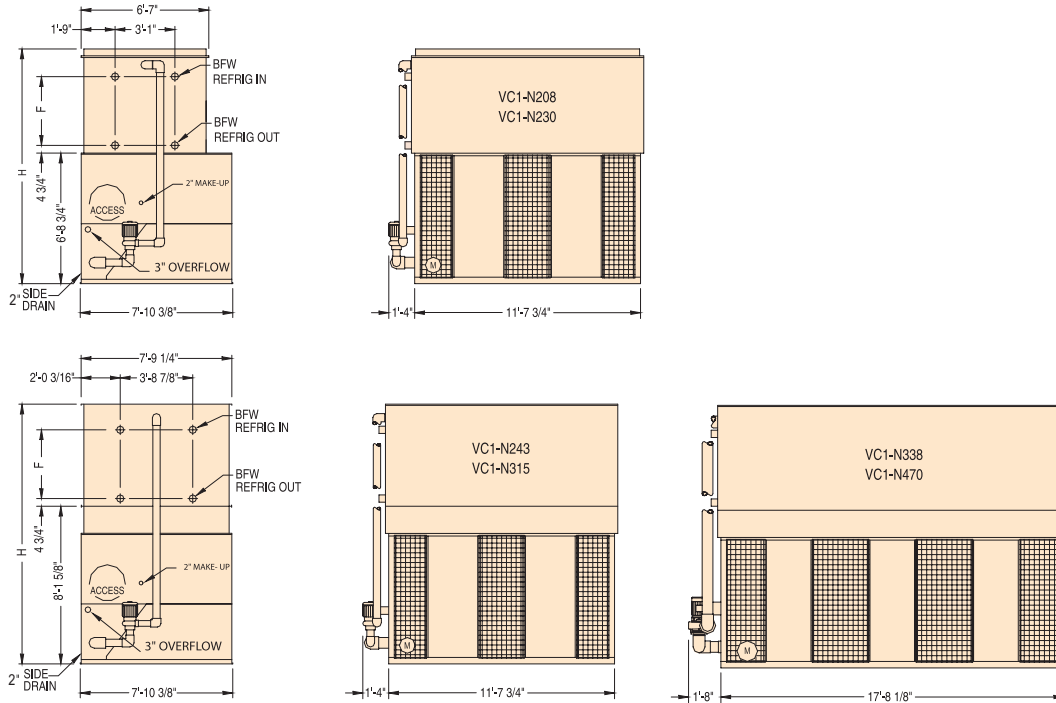

Nom. Box Size	Model Number <sup>1</sup>	Base Heat Rejection (MBH)	R-717 Tons <sup>2</sup>	Approx. Weights (lbs)			CFM	Motor HP <sup>3</sup> (0" ESP)	GPM	Pump Motor HP	R-717 Oper. Charge <sup>7</sup> (lbs.)	Internal Coil Volume (ft <sup>3</sup> )	Remote Sump			F	H
				Ship.	Heaviest Section <sup>5</sup>	Oper. <sup>4</sup>							Drain Size (in)	Approx. Oper. Weight	Gal. Req.		
6' x 12'	VC1-N208	3,058	148	10,170	6,580	13,710	39,650	15	305	2	230	25	6	11,460	360	33 1/4	135 7/8
	VC1-N230	3,381	163	11,410	8,220	15,000	38,550	15	305	2	245	31	6	12,750	360	42 1/2	145 1/8
8' x 12'	VC1-N243	3,572	172	10,720	7,050	15,140	46,150	20	385	3	290	32	6	13,040	360	33 1/4	153 1/8
	VC1-N257	3,778	182	10,770	7,050	15,190	49,700	25	385	3	290	32	6	13,090	360	33 1/4	153 1/8
	VC1-N275	4,043	195	12,130	8,460	16,700	44,800	20	385	3	360	40	6	14,600	360	42 1/2	162 3/8
	VC1-N301	4,425	213	13,580	9,860	18,210	47,150	25	385	3	430	47	6	16,110	360	51 3/4	171 5/8
	VC1-N315	4,631	223	13,600	9,860	18,230	50,100	30	385	3	430	47	6	16,130	360	51 3/4	171 5/8
8' x 18'	VC1-N338	4,969	240	15,630	10,390	22,360	60,450	20	580	5	435	48	8	19,110	520	33 1/4	153 1/8
	VC1-N357	5,248	253	15,680	10,390	22,410	65,100	25	580	5	435	48	8	19,160	520	33 1/4	153 1/8
	VC1-N373	5,483	265	15,700	10,390	22,430	69,200	30	580	5	435	48	8	19,180	520	33 1/4	153 1/8
	VC1-N417	6,130	296	17,880	12,570	24,820	67,200	30	580	5	540	59	8	21,570	520	42 1/2	162 3/8
	VC1-N470	6,909	333	20,250	14,750	27,410	72,250	40	580	5	645	71	8	24,160	520	51 3/4	171 5/8

**Notes:**

1. Model number denotes nominal tons using R-22 at a 105°F condensing temperature, a 40°F suction temperature, and a 78°F wet-bulb temperature.
2. R-717 tons are at a 96.3°F condensing temperature, a 20°F suction temperature, and a 78°F wet-bulb temperature.
3. Fan horsepower is at 0" external static pressure.

4. Operating weight shown is based on total unit weight, weight of refrigerant operating charge, and cold water basin filled to the overflow level.
5. Unless otherwise noted, the coil section is the heaviest section.
6. Standard refrigerant connection size is 4" BFW (inlet and outlet).
7. Refrigerant charge listed is R-717 operating charge. To determine operating charge for R-22, multiply charge by 1.93. For R-134a, multiply by 1.98.

...because temperature matters™





# VC1 Models

**Do not use for construction.** Refer to factory certified dimensions. This handbook includes data current at the time of publication, which should be reconformed at the time of purchase. Up-to-date engineering data, free product selection software and more can be found at [www.BaltimoreAircoil.com](http://www.BaltimoreAircoil.com).

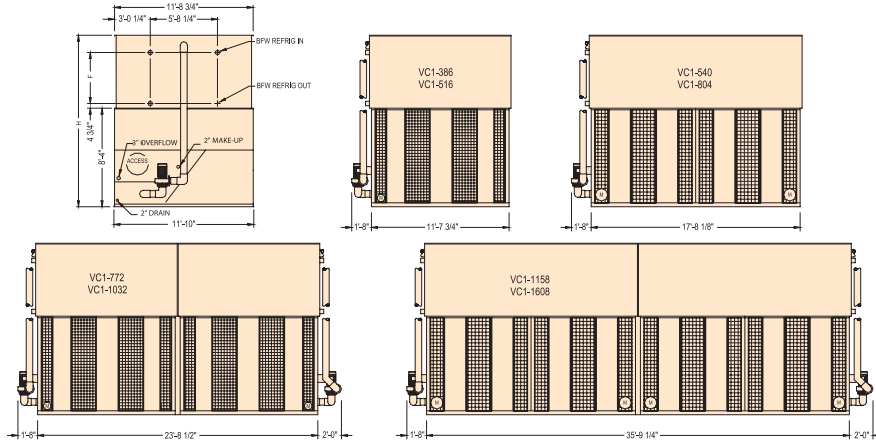

Nom. Box Size	Model Number <sup>1</sup>	Base Heat Rejection (MBH)	R-717 Tons <sup>2</sup>	Approx. Weights (lbs)			CFM	Motor HP <sup>3</sup> (0" ESP)	GPM	Pump Motor HP	R-717 Oper. Charge <sup>7</sup> (lbs.)	Internal Coil Volume (ft <sup>3</sup> )	Remote Sump			F	H
				Ship.	Heaviest Section <sup>5</sup>	Oper. <sup>4</sup>							Drain Size (in)	Approx. Oper. Weight	Gal. Req.		
12' x 12'	VC1-386	5,674	274	15,810	10,300	23,860	74,250	30	585	5	445	49	8	19,350	600	33 1/4	155 1/2
	VC1-436	6,409	309	17,880	12,370	26,140	72,050	30	585	5	550	60	8	21,630	600	42 1/2	164 3/4
	VC1-467	6,865	331	18,070	12,370	26,330	79,300	40	585	5	550	60	8	21,820	600	42 1/2	164 3/4
	VC1-454	6,674	322	19,950	14,440	28,430	70,400	30	585	5	655	72	8	23,920	600	51 3/4	174
	VC1-487	7,159	345	20,140	14,440	28,620	77,500	40	585	5	655	72	8	24,110	600	51 3/4	174
	VC1-516	7,585	366	20,180	14,440	28,660	83,450	50	585	5	655	72	8	24,150	600	51 3/4	174
12' x 18'	VC1-540	7,938	383	22,850	15,170	35,090	97,250	(2) 15	835	5	665	72	10	28,530	710	33 1/4	155 1/2
	VC1-579	8,511	411	22,870	15,170	35,110	107,050	(2) 20	835	5	665	72	10	28,550	710	33 1/4	155 1/2
	VC1-612	8,996	434	22,970	15,170	35,210	115,300	(2) 25	835	5	665	72	10	28,650	710	33 1/4	155 1/2
	VC1-646	9,496	458	25,990	18,290	38,560	103,900	(2) 20	835	5	825	90	10	32,000	710	42 1/2	164 3/4
	VC1-683	10,040	484	26,090	18,290	38,660	111,950	(2) 25	835	5	825	90	10	32,100	710	42 1/2	164 3/4
	VC1-715	10,511	507	26,130	18,290	38,700	118,950	(2) 30	835	5	825	90	10	32,140	710	42 1/2	164 3/4
	VC1-748	10,996	530	29,240	21,400	42,140	116,200	(2) 30	835	5	990	108	10	35,580	710	51 3/4	174
	VC1-804	11,819	570	29,620	21,400	42,520	127,900	(2) 40	835	5	990	108	10	35,960	710	51 3/4	174
12' x 24'	VC1-772	11,348	548	31,560	* 10,960	47,930	148,500	(2) 30	1,170	(2) 5	890	98	10	39,760	1,360	33 1/4	155 1/2
	VC1-872	12,818	618	35,700	12,370	52,490	144,100	(2) 30	1,170	(2) 5	1,100	121	10	44,320	1,360	42 1/2	164 3/4
	VC1-934	13,730	662	36,080	12,370	52,870	158,600	(2) 40	1,170	(2) 5	1,100	121	10	44,700	1,360	42 1/2	164 3/4
	VC1-908	13,348	644	39,840	14,440	57,070	140,800	(2) 30	1,170	(2) 5	1,310	144	10	48,900	1,360	51 3/4	174
	VC1-974	14,318	691	40,220	14,440	57,450	155,000	(2) 40	1,170	(2) 5	1,310	144	10	49,280	1,360	51 3/4	174
	VC1-1032	15,170	732	40,300	14,440	57,530	166,900	(2) 50	1,170	(2) 5	1,310	144	10	49,360	1,360	51 3/4	174
12' x 36'	VC1-1158	17,023	821	45,710	* 15,340	70,450	214,100	(4) 20	1,670	(2) 5	1,330	146	12	57,180	2,090	33 1/4	155 1/2
	VC1-1224	17,993	868	45,910	* 15,540	70,650	230,600	(4) 25	1,670	(2) 5	1,330	146	12	57,380	2,090	33 1/4	155 1/2
	VC1-1366	20,080	969	52,120	18,290	77,520	223,900	(4) 25	1,670	(2) 5	1,650	181	12	64,250	2,090	42 1/2	164 3/4
	VC1-1430	21,021	1014	52,200	18,290	77,600	237,900	(4) 30	1,670	(2) 5	1,650	181	12	64,330	2,090	42 1/2	164 3/4
	VC1-1496	21,991	1061	58,420	21,400	84,480	232,400	(4) 30	1,670	(2) 5	1,980	216	12	71,210	2,090	51 3/4	174
	VC1-1608	23,638	1140	59,180	21,400	85,240	255,800	(4) 40	1,670	(2) 5	1,980	216	12	71,970	2,090	51 3/4	174

\* Basin section is heaviest section.

**Notes:**

1. Model number denotes nominal tons using R-22 at a 105°F condensing temperature, a 40°F suction temperature, and a 78°F wet-bulb temperature.
2. R-717 tons are at a 96.3°F condensing temperature, a 20°F suction temperature, and a 78°F wet-bulb temperature.
3. Fan horsepower is at 0" external static pressure.
4. Operating weight shown is based on total unit weight, weight of refrigerant operating charge, and cold water basin filled to the overflow level.
5. Unless otherwise noted, the coil section is the heaviest section.
6. Standard refrigerant connection size is 4" BFW (inlet and outlet).
7. Refrigerant charge listed is R-717 operating charge. To determine operating charge for R-22, multiply charge by 1.93. For R-134a, multiply by 1.98.



# VC1 Models

**Do not use for construction.** Refer to factory certified dimensions. This handbook includes data current at the time of publication, which should be reconfirmed at the time of purchase. Up-to-date engineering data, free product selection software and more can be found at [www.BaltimoreAircoil.com](http://www.BaltimoreAircoil.com).

Designed to minimize ocean freight costs, VC1-C models fit in standard dry van containers.

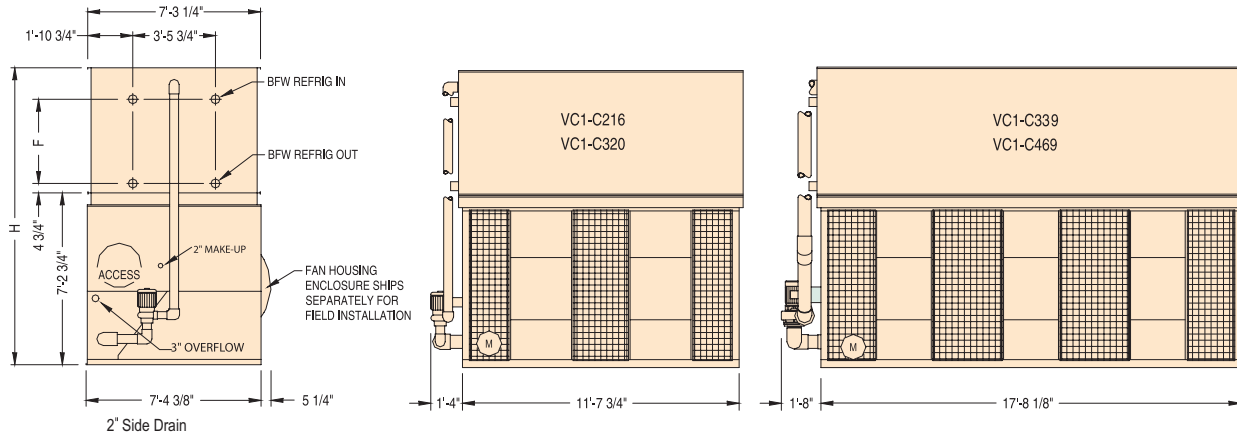

Refrigeration

Nom. Box Size	Model Number <sup>1</sup>	Base Heat Rejection (MBH)	R-717 Tons <sup>2</sup>	Approx. Weights (lbs)			CFM	Motor HP <sup>3</sup> (0\"/>
				Ship.	Heaviest Section <sup>5</sup>	Oper. <sup>5</sup>		
7'4\"/>								

**Notes:**

- Model number denotes nominal tons using R-22 at a 105°F condensing temperature, a 40°F suction temperature, and a 78°F wet-bulb temperature.
- R-717 tons are at a 96.3°F condensing temperature, a 20°F suction temperature, and a 78°F wet-bulb temperature.
- Fan horsepower is at 0\"/>

*...because temperature matters™*



# VCL Models

**Do not use for construction.** Refer to factory certified dimensions. This handbook includes data current at the time of publication, which should be reconfirmed at the time of purchase. Up-to-date engineering data, free product selection software and more can be found at [www.BaltimoreAircoil.com](http://www.BaltimoreAircoil.com).

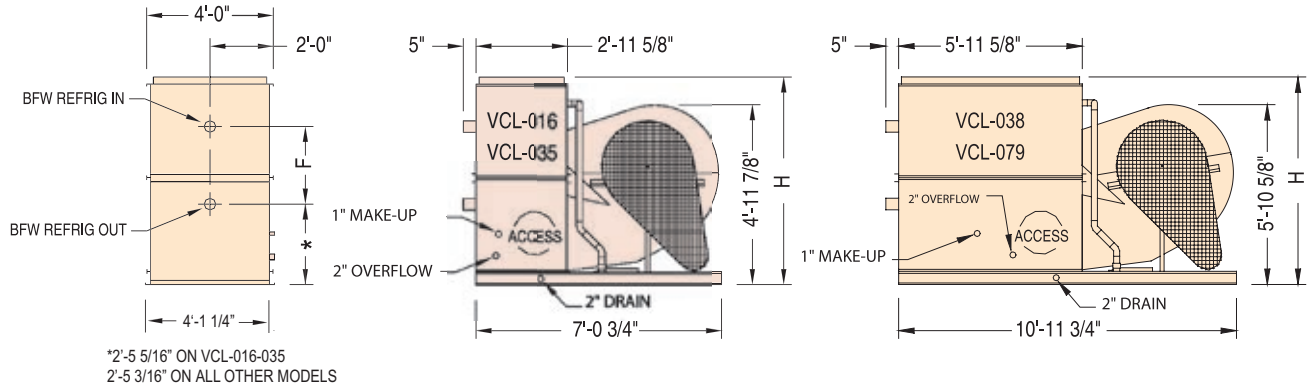

Nom. Box Size	Model Number <sup>1</sup>	Base Heat Rejection (MBH)	R-717 Tons <sup>2</sup>	Approx. Wt.			Motor HP <sup>3</sup> (0" ESP)	Pump Motor HP	R-717 Oper. Charge <sup>7</sup> (lbs.)	Internal Coil Volume (ft <sup>3</sup> )	Remote Sump			F	H	
				Ship. (lbs)	Oper. <sup>4</sup> (lbs)	CFM					Drain Size (in)	Approx. Oper. Weight	Gal. Req.			
4' x 3'	VCL-016	235	11	1,660	2,210	7,040	1	45	1/3	23	2.5	3	1,860	40	14 1/4	62 1/4
	VCL-019	279	13	1,690	2,240	8,310	2	45	1/3	23	2.5	3	1,890	40	14 1/4	65
	VCL-024	353	17	1,900	2,470	8,010	2	45	1/3	34	3.3	3	2,120	40	22 3/4	75 3/4
	VCL-029	426	21	2,120	2,700	7,660	2	45	1/3	44	4.3	3	2,350	40	31 1/4	82
	VCL-035	515	25	2,360	2,960	8,140	3	45	1/3	52	5.2	3	2,610	40	39 3/4	90 1/2
4' x 6'	VCL-038	559	27	2,400	3,530	12,800	3	94	1/2	44	4.4	4	2,980	95	13 1/4	62 1/4
	VCL-044	647	31	2,760	3,940	12,620	2	94	1/2	62	6.3	4	3,390	95	21 3/4	73
	VCL-048	706	34	2,790	3,970	14,250	3	94	1/2	62	6.3	4	3,420	95	42 1/2	73
	VCL-054	794	38	2,810	3,990	16,150	5	94	1/2	62	6.3	4	3,440	95	21 3/4	75 3/4
	VCL-058	853	41	3,180	4,370	13,570	3	94	1/2	83	8.2	4	3,820	95	30 1/4	79 1/4
	VCL-065	956	46	3,200	4,390	15,600	5	94	1/2	83	8.2	4	3,840	95	30 1/4	79 1/4
	VCL-073	1,073	52	3,610	4,820	15,150	5	94	1/2	101	10	4	4,270	95	38 3/4	87 3/4
	VCL-079	1,161	56	3,680	4,890	16,690	7 1/2	94	1/2	101	10	4	4,340	95	38 3/4	90 1/2
4' x 9'	VCL-087	1,279	62	4,380	6,130	19,280	5	142	1	122	12	4	5,840	200	33 1/4	82 1/4
	VCL-096	1,411	68	4,410	6,160	21,570	7 1/2	142	1	122	12	4	5,870	200	33 1/4	82 1/4
	VCL-102	1,499	72	4,440	6,190	23,730	10	142	1	122	12	4	5,900	200	33 1/4	82 1/4
	VCL-108	1,588	77	4,990	6,770	21,200	7 1/2	142	1	159	15	4	6,480	200	42 1/2	92 9/16
	VCL-115	1,691	82	5,020	6,800	22,970	10	142	1	159	15	4	6,510	200	42 1/2	92 9/16
	VCL-120	1,764	85	5,620	7,440	22,210	10	142	1	182	18	4	7,150	200	51 3/4	100 3/4
4' x 12'	VCL-134	1,970	95	6,160	8,590	25,130	10	192	1 1/2	203	20	6	7,990	250	42 1/2	92 9/16
	VCL-148	2,176	105	6,220	8,650	28,400	15	192	1 1/2	203	20	6	8,050	250	42 1/2	92 9/16
	VCL-155	2,279	110	6,950	9,450	28,000	15	192	1 1/2	242	24	6	8,850	250	51 3/4	100 3/4
8' x 9'	VCL-167	2,455	118	8,030	11,570	36,870	10	284	1 1/2	244	24	6	10,850	385	33 1/4	82 1/4
	VCL-185	2,720	131	8,090	11,630	41,560	15	284	1 1/2	244	24	6	10,910	385	33 1/4	82 1/4
	VCL-209	3,072	148	9,270	12,870	40,780	15	284	1 1/2	317	30	6	12,150	385	42 1/2	92 9/16
	VCL-223	3,278	158	9,280	12,880	44,290	20	284	1 1/2	317	30	6	12,160	385	42 1/2	92 9/16
	VCL-234	3,440	166	10,460	14,140	43,480	20	284	1 1/2	364	35	6	13,420	385	51 3/4	100 3/4
8' x 12'	VCL-257	3,778	182	11,080	16,000	47,860	20	384	2	406	40	8	14,260	405	42 1/2	92 9/16
	VCL-271	3,984	192	12,480	17,540	47,370	20	384	2	484	47	8	15,800	405	51 3/4	100 3/4
	VCL-286	4,204	203	12,520	17,580	50,670	25	384	2	484	47	8	15,840	405	51 3/4	100 3/4
	VCL-299	4,395	212	12,560	17,620	53,520	30	384	2	484	47	8	15,880	405	51 3/4	100 3/4



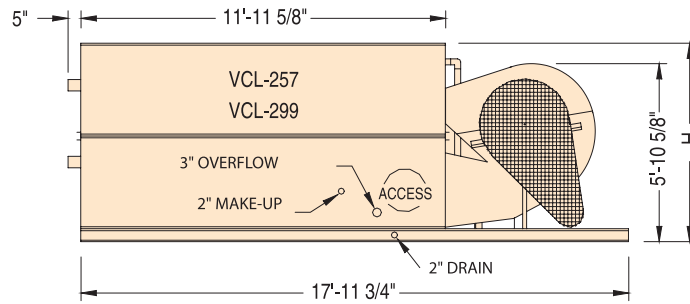
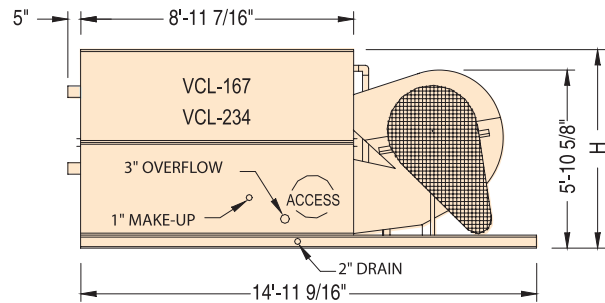
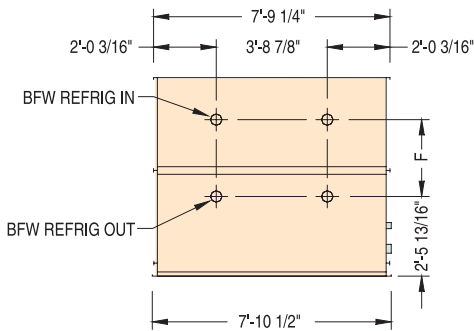
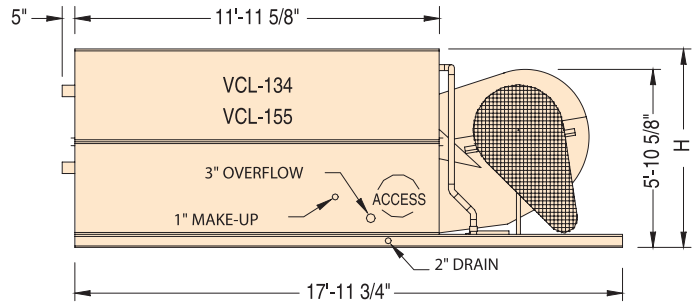
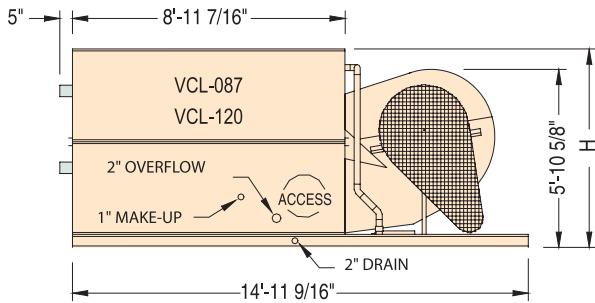

**Notes:**

1. Model number denotes nominal tons using R-22 at a 105°F condensing temperature, a 40°F suction temperature, and a 78°F wet-bulb temperature.
2. R-717 tons are at a 96.3°F condensing temperature, a 20°F suction temperature, and a 78°F wet-bulb temperature.
3. Fan horsepower is at 0" external static pressure.
4. Operating weight shown is based on total unit weight, weight of refrigerant operating charge, and cold water basin filled to the overflow level.
5. All models ship as a single piece.
6. Standard refrigerant connection size is 4" BFW (inlet and outlet).
7. Refrigerant charge listed is R-717 operating charge. To determine operating charge for R-22, multiply charge by 1.93. For R-134a, multiply by 1.98.





# Structural Support CXV, CXV-T Models

The primary support arrangement for the CXV is two parallel I-beams continuously supporting the full length of the unit. Alternates include a cantilevered plan, with a minimum “D” dimension indicated in the table below, or transverse steel. The steel support serves to adequately support the unit and may also serve to raise the unit above any solid foundation to assure access to the bottom of the basin.

Beam size should be calculated in accordance with accepted structural design practice. The maximum permissible beam deflection and center line distances between bolt holes are tabulated below.

Model Number	D	Optional Minimum D	Max. Deflection
CXV-64 to 95	8'-3"	6'-0"	3/16"
CXV-103 to 153	8'-3"	6'-0"	5/16"
CXV-160 to 192, 206	8'-3"	6'-0"	3/8"
CXV-196 to 305	11'-7 3/4"	9'-6"	3/8"
CXV-310 to 481	11'-7 3/4"	9'-6"	1/2"
CXV-N465 to N687	11'-7 3/4"	9'-6"	1/2"
CXV-420 to 610	11'-7 3/4"	9'-6"	3/8"
CXV-620 to 960	11'-7 3/4"	9'-6"	1/2"

\* When the unit is supported with a cantilever plan, the side opposite the air intake shall be cantilevered.

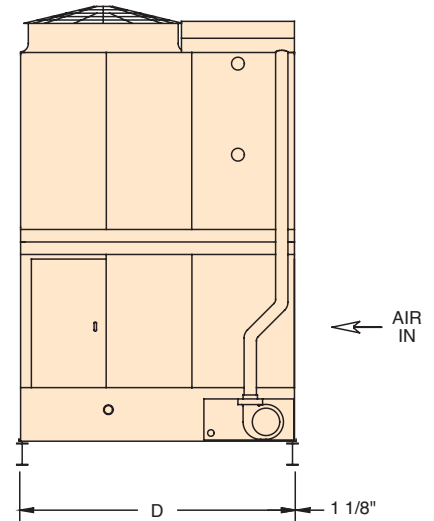

Model Number	A	Max Deflection
CXV-T645 to T792	23'-9 5/8"	1/2"
CXV-T791 to T944	26'-5/8"	1/2"
CXV-T1290 to T1584	23'-9 5/8"	1/2"

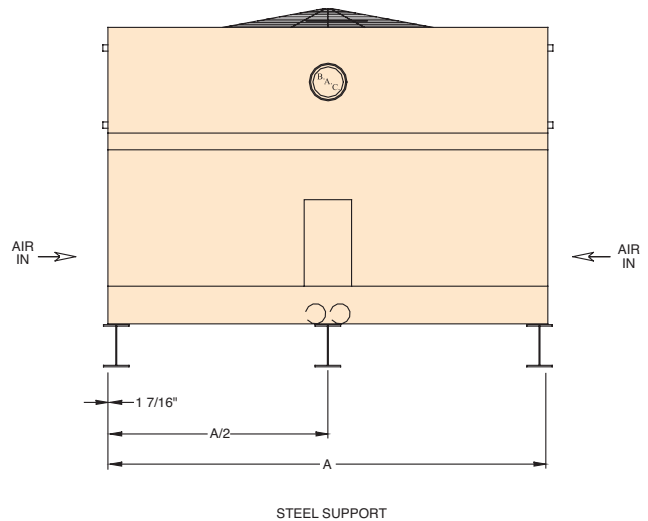



# Structural Support

## Series V Models

The recommended support arrangement for the Series V Evaporative Condenser consists of parallel I-beams running the full length of the unit. Besides providing support, the steel also serves to raise the unit above any solid foundation which might restrict air movement or prevent access to the unit. The steel support beam must be located directly beneath the unit and extend the full length of the basin section. Support beams and anchor bolts are to be furnished and installed by others. Refer to the BAC unit certified print for bolt hole location.

**NOTE:** Models VC1-386 through VC1-1608 and Models VC2-342 through VC2-1914 (12' wide units) can also be supported with beams on nominal 10' wide centers. In this case, the fan section will overhang the support steel approximately two feet. Contact your local BAC Representative for exact dimensions.

### Beam Size and Length

Beam size should be calculated in accordance with accepted structural practice. Use 65 percent of the operating weight as a uniform load on each beam. The length of the beam must be at least equal to the length of the basin. Refer to Engineering Data on page J37 for basin dimensions.

Maximum permissible beam deflection and center line distances between bolt holes are tabulated in the table to the right.

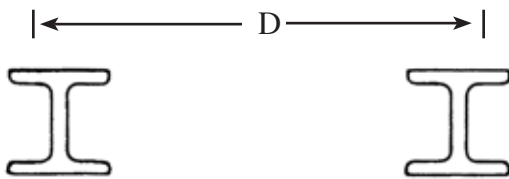

### Vibration Isolators

If vibration isolators are used, a rail or channel must be provided between the unit and the isolators to provide continuous support. Refer to vibration isolator drawings for the length of the rails and mounting hole locations, which may differ from the length and the hole locations of the unit itself.

Model Number	D	Max Deflection
VC2-N138 thru N191	4' 9-1/2"	3/8"
VC2-N206 thru N235	6' 4-1/4"	3/8"
VC2-N261 thru N301	7' 8"	3/8"
VC2-N356 thru N446	7' 8"	1/2"
VC2-319 thru 626	11' 7-1/4"	3/8"
VC2-526 thru 957	11' 7-1/4"	1/2"
VC2-N870 thru N1204	11' 7-1/4"	1/2"
VC2-684 thru 1252	11' 7-1/4"	1/2"
VC2-1052 thru 1914	11' 7-1/4"	1/2"
VXMC-300 thru 380	9' 7-1/2"	3/8"
VXMC-430 thru 1240	9' 7-1/2"	1/2"
VC1-10 thru 25	3' 9-3/8"	3/32"
VC1-30 thru 65	3' 9-3/8"	3/16"
VC1-72 thru 90	3' 9-3/8"	5/16"
VC1-100 thru 135	3' 9-3/8"	3/8"
VC1-150 thru 205	4' 6-1/4"	3/8"
VC1-N208 thru N315	7' 7-5/8"	3/8"
VC1-N338 thru N470	7' 7-5/8"	1/2"
VC1-386 thru 516	11' 7-1/4"	3/8"
VC1-540 thru 804	11' 7-1/4"	1/2"
VC1-772 thru 1032	11' 7-1/4"	1/2"
VC1-1158 thru 1608	11' 7-1/4"	1/2"
VC1-C216 thru C320	7' 1-5/8"	3/8"
VC1-C339 thru C469	7' 1-5/8"	1/2"
VCL-016 thru 035	3' 11"	1/4"
VCL-038 thru 079	3' 11"	3/8"
VCL-087 thru 120	3' 11"	1/2"
VCL-134 thru 155	3' 11"	1/2"
VCL-167 thru 234	7' 8-1/4"	1/2"
VCL-257 thru 299	7' 8-1/4"	1/2"

# Engineering Specifications

## CXV, CXV-T Models

See our website at [www.BaltimoreAircoil.com](http://www.BaltimoreAircoil.com) for an electronic copy of product engineering specifications.

### Part 1: General

- A.** General: Furnish and install, \_\_\_\_\_ factory assembled evaporative condenser(s) of induced draft design with vertical discharge, conforming in all aspects to the specifications and schedules as shown on the plans.
- B.** Capacity: The evaporative condenser(s) shall be warranted by the manufacturer to have condensing capacity of \_\_\_\_\_ BTUH (kW) heat rejection, operating with \_\_\_\_\_ refrigerant at \_\_\_\_\_ °F(°C) condensing temperature and \_\_\_\_\_ °F(°C) entering wet-bulb temperature.
- C.** Warranty: The manufacturer shall provide a five-year mechanical drive warranty covering the fans, fan shafts, bearings, sheaves, supports, and fan motors. The manufacturer's standard equipment warranty for the balance of the components shall be for a period of one year from the date of startup or eighteen months from the date of shipment, whichever ends first.
- D.** Factory Testing: The manufacturer shall be capable of testing the operation of the condenser in the manufacturer's own test facility. Test facilities shall be capable of simulating design conditions, including but not limited to design wet-bulb, airflow, refrigerant mass flow rate, refrigerant condensing temperature, and total heat rejection.
- E.** Quality Assurance: The manufacturer shall have a Management System certified by an accredited registrar as complying with the requirements of ISO-9001:2000 to ensure consistent quality of products and services. Manufacturers that are not ISO-9001:2000 certified shall provide an additional one year warranty to the customer at no additional cost.
- a.** The refrigerant condensing coil shall be pneumatically tested at 375 psig (2,687 kPa).
- b.** The refrigerant condensing coil shall be designed for low pressure drop with sloping tubes for free drainage of liquid refrigerant.
- c.** The refrigerant condensing coil shall be ASME B31.5 compliant and coils shipping into Canada shall be supplied with a CRN.
- 2.** Water shall be distributed evenly over the coil at a minimum flow rate of 10 gpm/ft<sup>2</sup> (6.8 lps/m<sup>2</sup>) to ensure complete wetting of the coil at all times. Large-diameter, non-clog, 360° plastic distribution nozzles shall be spaced across the coil face area in Schedule 40 PVC spray branches. Nozzles shall utilize a two-stage diffusion pattern to provide overlapping, umbrella spray patterns that create multiple intersection points with adjacent nozzles.
- a.** Nozzles and spray branches shall be observable and accessible for cleaning from the outside of the evaporative condenser during condenser operation without the removal of other components.
- b.** Spray branches and nozzles shall be held in place by snap-in rubber grommets, allowing quick removal of individual nozzles or complete branches for cleaning or flushing.
- 3.** Removable PVC drift eliminators shall be positioned to prevent moisture from entering the air plenum and incorporate a minimum of three (3) changes in air direction.
- 4.** Fan(s) shall be heavy-duty, axial type with aluminum alloy blades driven by a one-piece, multi-groove neoprene/polyester belt designed for a minimum of 150% of the motor nameplate horsepower.
- a.** Fan(s) and shafts shall be supported by heavy-duty, self aligning, grease-packed ball bearings with moisture-proof seals and integral sealer rings, designed for a minimum L<sub>10</sub> life of 40,000 hours (280,000 hours average life).
- b.** Fan and motor sheaves shall be fabricated from corrosion resistant materials.
- c.** Fan motor(s) shall be totally enclosed air over (TEAO) type with a 1.15 service factor, suitable for \_\_\_\_\_ volt, \_\_\_\_\_ phase, \_\_\_\_\_ Hz electrical service and shall be mounted on an easily adjusted, heavy-duty motor base.
- d.** The motor shall be furnished with double-sealed, permanently lubricated bearings and special moisture protection on windings, shafts and bearings.
- e.** Air plenum shall provide a minimum of 48" (1220 mm) clearance under the motor base to provide comfortable working space for service personnel.

### Part 2: Products

#### 2.01 Evaporative Condenser Materials and Components

- A.** General: All steel panels and structural elements shall be constructed from heavy-gauge, G-235 (Z700 metric) hot-dip galvanized steel, with cut edges given a protective coating of zinc-rich compound.
- Or, for CXV-T Models**
- A.** General: All steel panels and structural elements shall be constructed from heavy-gauge, G-235 (Z700 metric), hot-dip galvanized steel, with cut edges given a protective coating of zinc-rich compound. Casing panels shall be constructed of corrosion resistant, fiberglass, reinforced polyester (FRP).

#### 2.02 Coil Casing Assembly

- A.** The evaporative condenser shall include a coil casing section consisting of refrigerant condensing coil, spray water distribution system, drift eliminators, and air plenum with fan assemblies as indicated by the manufacturer.
- 1.** The refrigerant condensing coil shall be fabricated of continuous lengths of all prime surface steel at the manufacturer's own facility, and hot-dip galvanized after fabrication.





### 2.03 Basin Assembly

A. The evaporative condenser shall include a basin assembly consisting of cold water basin with pump assembly, heat transfer section for spray water cooling with integral drift eliminators, and wide spaced air inlet louvers.

1. The cold water basin shall be constructed of heavy-gauge steel panels and structural members. Basin shall include a depressed section with drain/cleanout connection. The basin area under the fill surface shall be sloped toward the depressed section to facilitate cleaning.

- OR -

1. The cold water basin shall be constructed of heavy-gauge Series 300 stainless steel panels and structural members, with all welded seams. The welded stainless steel basin shall be leak tested at the factory. Basin shall include a depressed section with drain/cleanout connection. The basin area under the fill surface shall be sloped toward the depressed section to facilitate cleaning.

2. The cold water basin shall include: a drain/clean-out connection; a steel strainer; a brass make-up valve; overflow connection; and a water recirculation pump assembly.

- a. Cold water basin shall be designed so that the strainer, makeup valve and float, and pump assembly are easily accessible without removing any of the unit panels or other components.
- b. Lift-out steel strainer shall be supplied with perforated openings sized smaller than the water distribution nozzle orifices and an integral anti-vortexing hood to prevent air entrainment.
- c. Water recirculation pump shall be a close-coupled, bronze-fitted centrifugal pump equipped with a mechanical seal, mounted on the basin and piped from the suction strainer to the water distribution system.
  - i. The pump shall be installed with adequate drains so that it may drain freely when the basin is drained.
  - ii. The pump assembly shall include an integral metering valve and bleed line to control the bleed rate from the pump discharge to the overflow connection.
  - iii. The pump motor shall be totally enclosed fan cooled (TEFC) type suitable for \_\_\_\_\_ volt, \_\_\_\_\_ phase, \_\_\_\_\_ Hz electrical service.

d. On installations requiring a remote sump, the evaporative condenser shall be modified to accommodate the use of an independent sump and pump for recirculating water (by others).

- i. The recirculating water pump, steel strainer, make-up valve, and integral bleed line assemblies shall be omitted from the evaporative condenser scope of supply.
- ii. The evaporative condenser shall be supplied with a cold water basin outlet sized and located as indicated on the drawings for gravity drain to the remote sump.
- iii. The water distribution system shall have a design operating pressure of 1 psig (108.25 kPa) at the evaporative condenser spray water inlet connection.

3. The heat transfer section shall consist of fill with integral drift eliminators for cooling the spray water leaving the coil to optimize the thermal performance of the evaporative condenser.

- a. The fill and integral drift eliminators shall be formed from self-extinguishing (per ASTM-568) polyvinyl chloride (PVC) having a flame spread rating of 5 per ASTM E84.
- b. The fill and integral drift eliminators shall be impervious to rot, decay, fungus, and biological attack.

4. The air inlet louvers shall be manufactured of wave-formed, fiberglass-reinforced polyester (FRP) widely spaced to minimize air resistance and prevent water splash-out.

### 2.04 Optional Equipment Specifications

A. Evaporative condenser shall be provided with basin heaters to prevent freezing of the recirculating water when the evaporative condenser is idle.

1. The basin heaters shall be selected to maintain +40°F (4.4°C) basin water temperature at a 0°F (-17.8°C) ambient temperature and 10 mph (16.1 km/hr) wind speed.
2. Basin heaters shall be electric immersion type controlled by a remote thermostat with the sensing bulb located in the basin water.
3. Basin heaters shall be provided with a low water level cutout switch to prevent heater operation unless the heater elements are adequately submerged.

B. The evaporative condenser shall be provided with extended lubrication lines with standard grease fittings for lubricating the fan shaft bearings from the outside base of the condenser.

C. Evaporative condenser shall be supplied with dedicated motors and drives so that each fan can be cycled independently.

D. The evaporative condenser shall be provided with a factory assembled, field-installed external platform with an access ladder and handrails complying with OSHA standards and regulations to provide access to the top of the evaporative condenser.

1. External platform shall have a 24" (610 mm) wide non-skid walking surface and 42" (1,220 mm) high safety railings.
2. Optional ladder safety cage shall be available to meet OSHA requirements as necessary.

Or, for CXV-T Models

D. The evaporative condenser shall be provided with factory assembled, field installed perimeter safety railings and walking surface above coil air intake to provide access to the top of the evaporative condenser.

E. Evaporative condenser shall be provided with a moveable ladder with fixed ladder supports to provide access to the fan drive system and coil assembly.

F. Evaporative condenser shall be provided with an internal walk way at the access door to facilitate servicing the unit.

G. Evaporative condenser shall be provided with a factory assembled internal working platform with ladder to provide a permanent working surface for maintenance personnel (CXV-193 and larger only).

H. Evaporative condenser shall be provided with the ENERGY-MISER® Fan System, which provides two-single speed fan motors, one sized for full horsepower and load, the other sized for 1/3 the full horsepower and approximately 75% full load for capacity control and stand-by protection from drive or motor failure.

I. Evaporative condenser shall be supplied with a right angle gear drive designed specifically for evaporative condenser service. All gears shall have a minimum service factor of 2.0 based on design fan horsepower. An oil level fill port and sight glass shall be located on the gear drive to facilitate routine inspection and maintenance.

J. BALTI GUARD PLUS™ Fan System: Two single speed fan motors, one sized for load, the other sized for 1/3 of the full load horsepower shall be provided in each cell for capacity control and standby protection from drive or motor failure. The manufacturer of the equipment shall supply controls for the larger motor, a VFD for the smaller motor and factory programmed logic controller to maximize energy saving for off peak load and wet-bulb conditions.



# Engineering Specifications

## Series V Models

See our website at [www.BaltimoreAircoil.com](http://www.BaltimoreAircoil.com) for an electronic copy of product engineering specifications.

### Part 1: General

- A. General: Furnish and install, \_\_\_\_\_ factory assembled evaporative condenser(s) of counterflow blow-through design, with single side entry, conforming in all aspects to the specifications and schedule as shown on the plans.
- B. Capacity: The evaporative condenser(s) shall be warranted by the manufacturer to have condensing capacity of \_\_\_\_\_ BTUH (kW) heat rejection, operating with \_\_\_\_\_ refrigerant and \_\_\_\_\_°F (°C) condensing temperature and \_\_\_\_\_°F(°C) entering wet-bulb temperature.
- C. Warranty: The manufacturer's standard equipment warranty shall be for a period of one year from the date of startup or eighteen months from the date of shipment, whichever ends first. The manufacturer shall, in addition, provide a 5-year mechanical drive warranty covering the fans, fan shafts, bearings, sheaves, supports, and fan motors.
- D. Factory Testing: Equipment manufacturer shall be capable of testing the operation of the condenser in the manufacturer's own test facility. Test facilities shall be capable of simulating design conditions, including but not limited to design wet-bulb, airflow, refrigerant mass flow rate, refrigerant condensing temperature, and total heat rejection.
- E. Quality Assurance: The manufacture shall have a Management System certified by an accredited registrar as complying with the requirements of ISO-9001 to ensure consistent quality of products and services. Manufacturers that are not ISO-9001 certified shall provide an additional one-year warranty to the customer at no additional cost.

### Part 2: Parts

#### 2.01 Evaporative Condenser Materials and Components

- A. General: All steel panels and structural elements shall be constructed from heavy-gauge, G-235 (Z700 metric) hot-dip galvanized steel, with cut edges given a protective coating of zinc-rich compound.

#### 2.02 Coil Casing Assembly

- A. The evaporative condenser shall include a coil casing section consisting of a refrigerant condensing coil, a spray water distribution system, and drift eliminators as indicated by the manufacturer.
  1. The refrigerant condensing coil shall be fabricated of all prime surface steel at the manufacturer's own facility, and hot-dip galvanized after fabrication.
    - a. The refrigerant condensing coil shall be tested at 375 psig (2,687 kPa) air pressure under water.
    - b. The refrigerant condensing coil shall be designed for low pressure drop with sloping tubes for free drainage of liquid refrigerant.
    - c. The refrigerant condensing coil shall be ASME B31.5 compliant and coils shipping into Canada shall be supplied with a CRN.
  2. Water shall be distributed evenly over the coil at a minimum flow rate of 4.5 gpm/ft<sup>2</sup> (3.1 lps/m<sup>2</sup>) to ensure complete wetting of the coil at all times by large-diameter, non-clog, 360° plastic distribution nozzles spaced across the coil face

area in Schedule 40 PVC spray branches. Nozzles shall utilize a two-stage diffusion pattern to provide overlapping, umbrella spray patterns that create multiple intersection points with adjacent nozzles.

- a. Directional nozzles shall not be acceptable.
  - b. Spray branches and nozzles shall be held in place by snap-in rubber grommets, allowing quick removal of individual nozzles or complete branches for cleaning or flushing.
  - c. Nozzles shall have a minimum of 0.25" (6.35 mm) protrusion inside the spray branches to ensure unimpeded water flow between regular cleanings of the water distribution system.
3. Removable PVC drift eliminators shall be positioned to prevent moisture from leaving the evaporative condenser and incorporate a minimum of three (3) changes in air direction.

#### 2.03 Basin Assembly

- A. The evaporative condenser shall include a basin assembly consisting of cold water basin with pump assembly and fan assemblies with single side air inlet and integral air plenum.
  1. The cold water basin shall include: a drain/clean-out connection; a steel strainer; a brass make-up valve; overflow connection; and a water recirculation pump assembly.
    - a. Drain/cleanout connection shall be located in the cold water basin to allow removal of recirculating water.
    - b. Lift-out steel strainer shall be supplied with perforated openings sized smaller than the water distribution nozzle orifices and an integral anti-vortexing hood to prevent air entrainment.
    - c. Brass make-up valve shall be supplied with a large-diameter plastic float arranged for easy adjustment.
    - d. Overflow connection shall be provided in the cold water basin to protect against recirculating water spillage.
    - e. Water recirculation pump shall be a close-coupled, bronze-fitted centrifugal pump equipped with a mechanical seal, mounted on the basin and piped from the suction strainer to the water distribution system.
      - i. The pump shall be installed so that it may drain freely when the basin is drained.
      - ii. The pump assembly shall include an integral metering valve and bleed line to control the bleed rate from the pump discharge to the overflow connection.
      - iii. The pump motor shall be totally enclosed fan cooled (TEFC) type suitable for \_\_\_\_\_ V, \_\_\_\_\_ phase, \_\_\_\_\_ Hz electrical service.
  - f. On installations requiring a remote sump, the evaporative condenser shall be modified to accommodate the use of an independent sump and pump for recirculating water (by others)
    - i. The recirculating water pump, steel strainer, make-up valve, and integral bleed line assemblies shall be omitted from the evaporative condenser scope of supply.
    - ii. The evaporative condenser shall be supplied with a cold water basin outlet sized and located as indicated on the drawings for gravity drain to the remote sump.





- iii. The water distribution system shall have an operating pressure of 2 psig (115 kPa) at the evaporative condenser spray water inlet connection.

### VC2 and VXMC Models

2. Air shall enter the evaporative condenser through the axial fan assemblies and integral air plenum.
  - a. Fans and motors shall be located in the dry entering airstream to provide greater reliability and ease of maintenance.
  - b. Fan motors and drives shall be located at the front base of the unit to facilitate access without requiring access to the inside of the unit.
  - c. Fan cylinders shall have curved inlets for efficient air entry.
  - d. Each fan assembly shall contain two axial-flow fans mounted in series on a common shaft with discharge guide vanes between the fans for increased fan efficiency.
  - e. Fans shall be heavy-duty, axial flow type with aluminum alloy blades driven by a one-piece, multi-groove neoprene/polyester belt designed for a minimum of 150% of the motor nameplate horsepower.
    - i. Fan shafts shall be mounted in heavy-duty, self-aligning, grease-packed relubricatable ball bearings with eccentric locking collars, designed for a minimum L<sub>10</sub> life of 40,000 hours (280,000 hours average life).
    - ii. Bearing lubrication lines shall be extended to the exterior of the unit.
    - iii. Fan and motor sheaves shall be fabricated from corrosion-resistant materials.
  - f. Fan motor(s) shall be totally enclosed fan cooled (TEFC) type with a 1.15 service factor, suitable for \_\_\_\_\_ V, \_\_\_\_\_ phase, \_\_\_\_\_ Hz electrical service and shall be mounted on an easily adjusted, heavy-duty motor base.
  - g. Integral air plenum shall contain additional guide vanes to ensure uniform airflow into the coil casing section.

### VC1 Models

2. Air shall enter the evaporative condenser through the centrifugal fan assemblies and integral air plenum.
  - a. Fans and motors shall be located in the dry entering air stream to provide greater reliability and ease of maintenance.
  - b. Fan housings shall have curved inlet rings for efficient air entry and rectangular discharge cowls that extend into the pan to increase fan efficiency and prevent water from entering the fans.
  - c. Fan housings on units more than 8' wide shall be split to facilitate the removal of the fan shaft.
  - d. Fan(s) shall be heavy-duty, centrifugal flow type mounted on a steel shaft with heavy-duty, self-aligning, relubricatable bearings with cast iron housings, designed for a minimum L<sub>10</sub> life of 40,000 hours (280,000 hours average life).
  - e. Fan motor(s) shall be totally enclosed fan cooled (TEFC) type with a 1.15 service factor, suitable for \_\_\_\_\_ V, \_\_\_\_\_ phase, \_\_\_\_\_ Hz electrical service and shall be mounted on an easily adjusted, heavy-duty motor base. Special moisture protection shall be furnished on the windings, shafts, and bearings.

### VCL Models

2. Air shall enter the evaporative condenser through the centrifugal fan assemblies and integral air plenum.

- a. Centrifugal fan assemblies shall be located adjacent to the casing and the cold water basin to minimize overall unit height.
- b. Fan housings shall have curved inlet rings for efficient air entry and rectangular discharge cowls which extend into the pan to increase fan efficiency and prevent water from entering the fans.
- c. Fan housings shall be split to facilitate the removal of the fan shaft.
- d. Fan(s) shall be heavy-duty, centrifugal flow type mounted on a steel shaft with heavy-duty, self-aligning, relubricatable bearings with cast iron housings, designed for a minimum L<sub>10</sub> life of 40,000 hours (280,000 hours average life).
- e. Fan motor(s) shall be totally enclosed fan cooled (TEFC) type with a 1.15 service factor, suitable for \_\_\_\_\_ V, \_\_\_\_\_ phase, \_\_\_\_\_ Hz electrical service and shall be mounted on an easily adjusted, heavy-duty motor base. Special moisture protection shall be provided on the windings, shafts and bearings.

### 2.04 Optional Equipment Specifications

- A. Evaporative condenser shall be provided with basin heaters to prevent freezing of the water in the cold water basin when the evaporative condenser is idle.
  1. The basin heaters shall be selected to maintain +40° F (4.4° C) basin water temperature at a 0° F (-17.8° C) ambient temperature and 10 mph (16.1 km/hr) wind speed.
  2. Basin heaters shall be electric immersion type controlled by a remote thermostat with the sensing bulb located in the basin water.
  3. Basin heaters shall be provided with a factory-installed low water level cutout switch to prevent heater operation unless the heater elements are fully submerged.
- B. Evaporative condenser shall be supplied with dedicated motors and drives so that each fan can be cycled independently, and an internal baffle shall be supplied to deter air bypass within the unit.
- C. Evaporative condenser shall be provided with a factory assembled, field-installed external platform with an access ladder and handrails complying with OSHA standards and regulations to provide access to the top of the evaporative condenser.
  1. External platform shall have a 24" (610 mm) wide non-skid walking surface and 42" (1,220 mm) high safety railings.
  2. Optional ladder/safety cage shall be available to meet OSHA requirements as necessary.
- D. Evaporative condenser shall be supplied with the ENERGY-MISER® Fan System to improve part load efficiency and provide system redundancy in case of a motor failure.
  1. The ENERGY-MISER® Fan System shall include the main fan motor as listed in the manufacturer's published literature and a pony motor sized for approximately 1/3 of design horse power and 2/3 of design fan speed to optimize energy savings during non-design load conditions.
- E. BALTI GUARD PLUS™ Fan System: Two single speed fan motors, one sized for load, the other sized for 1/3 of the full load horsepower shall be provided in each cell for capacity control and standby protection from drive or motor failure. The manufacturer of the equipment shall supply controls for the larger motor, a VFD for the smaller motor and factory programmed logic controller to maximize energy saving for off peak load and wet-bulb conditions.