

# SIZE REDUCTION SYSTEMS

**FITZ<sup>®</sup>MILL**

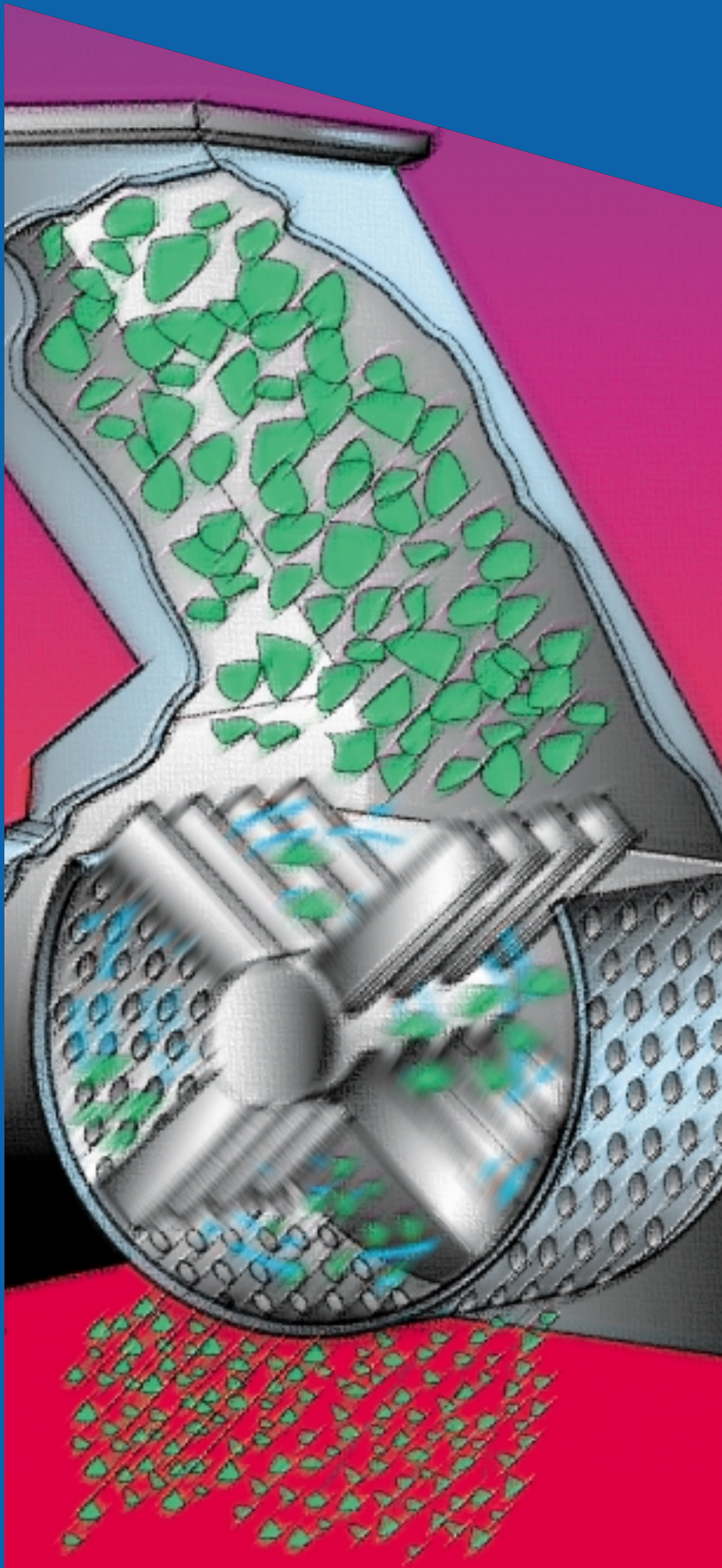

**CONTROLLED  
PARTICLE SIZE  
REDUCTION.  
PREDICTABLE  
RESULTS.**

**THE  
FITZPATRICK  
COMPANY**

# THE PROCESS

## COM•MI•NUTE (kŏm 'ə-nŏŏt') *tr. v.* **Controlled size reduction with predictable and repeatable results.**

Comminution has evolved into more than hammer-milling or grinding. The Fitzpatrick Company has perfected FitzMill® comminution equipment to precisely control the particle size reduction process. Equipment variables that affect process results include:

### THE FEED THROAT

Introduces material on a tangential path to the comminuting chamber.

### BLADE PROFILE

Helps determine degree of reduction based on material being processed

### SCREEN TYPE

Helps regulate particle output within a specified size range

### ROTOR SPEED

Works with screen to regulate particle output within the size range

### THE BENEFITS OF CONTROLLED PARTICLE REDUCTION

Particle size affects any number of characteristics in the manufacturing process. Controlled particle size helps assure that your production will be consistent and repeatable with respect to:

- COLOR - uniform particles assure batch-to-batch color consistency
- TASTE - allows precise portion control for consistent taste
- FLOWABILITY - critical to packaging, tableting, weighing
- UNIFORMITY - consistent bulk density
- DENSITY - helps control shipping costs and minimize dust
- RECONSTITUTION - assures the desired dissolution rate
- CHEMICAL REACTION - vital for uniform, controlled chemical change

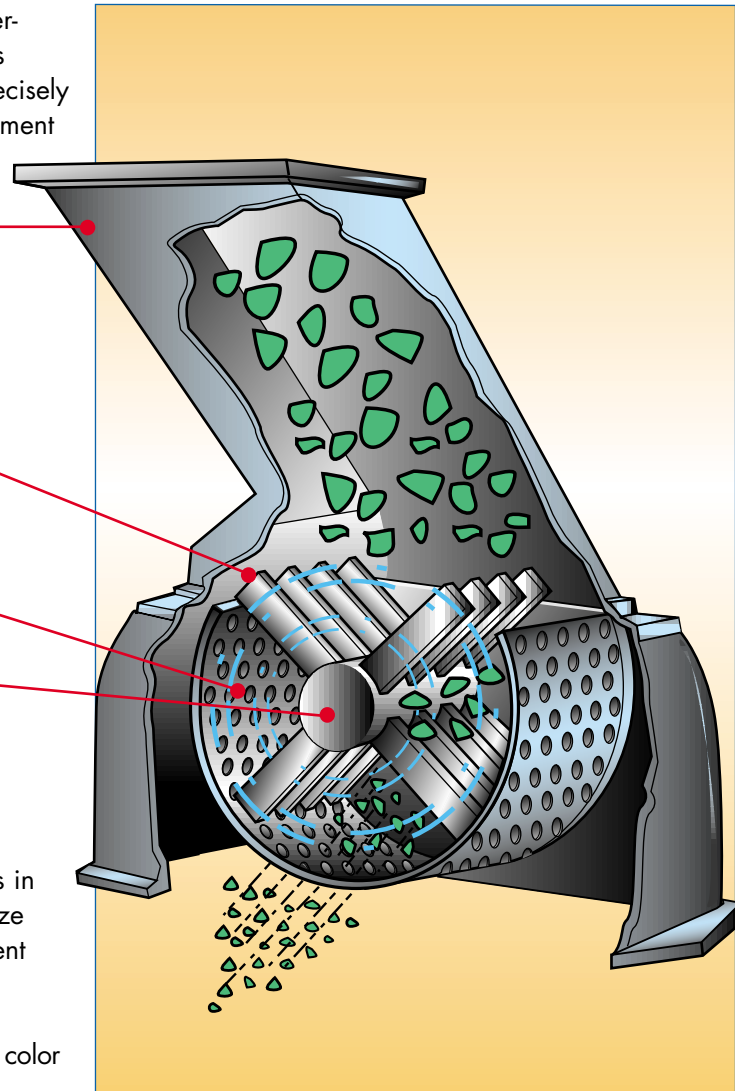



**THE FEED THROAT**

(SEE PAGE 10)

Controllable comminution requires that product be introduced into the processing chamber on a tangential path relative to the machine's milling blades. FitzMill feed throats provide exacting control over feed angle, assuring consistent, predictable results. Fitzpatrick offers a wide range of standard and custom throats. If your process requires heat transfer or introduction of inert gas, a special throat can be provided.

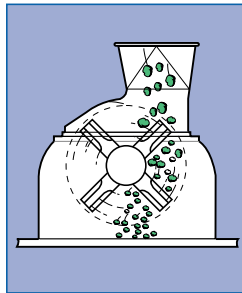

Forward, vertical inlet - best for fragile material

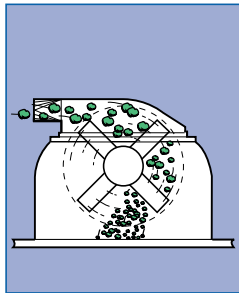

Horizontal inlet - best for fine grinds

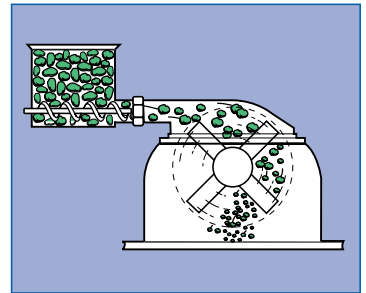

Throat with automatic feed assures uniform feed rate

**ROTOR/BLADE ASSEMBLY**

(SEE PAGE 9)

At the heart of each FitzMill® comminutor is a rotor and blade assembly. Blades may be fixed or swinging, and can be either knife-edged for gentle granulation or impact-edged for more aggressive reduction. Blades with one edge type on either side are also available for versatility. A variety of blade profiles assures the best match for your product requirements.

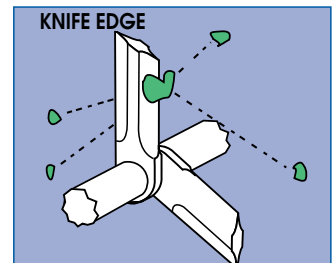
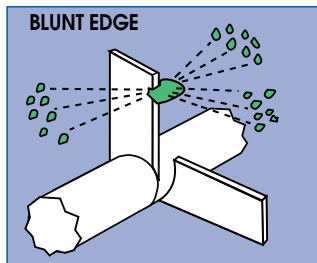

**SCREEN TYPE AND ROTOR SPEED**

(SEE PAGE 8)

For every combination of rotor speed and screen, particles in a certain size range are permitted to pass through the FitzMill's screen and exit the machine. Higher rotor speeds flatten the approach angle of a particle relative to a screen's surface, effectively reducing the screen's hole size (see Figure A). A circular hole, for example, appears elliptical, thereby allowing only smaller particles to pass through. At slower speeds, the approach angle increases, allowing larger particles to pass through. As screen gauge increases, opening size must also increase to maintain desired particle size (see Figure B). Variable rotor speed and screen interchangeability make it easy for a single FitzMill to produce a variety of results.

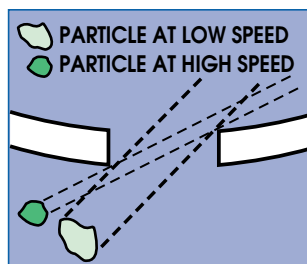

Fig. A

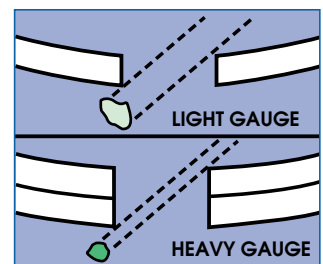
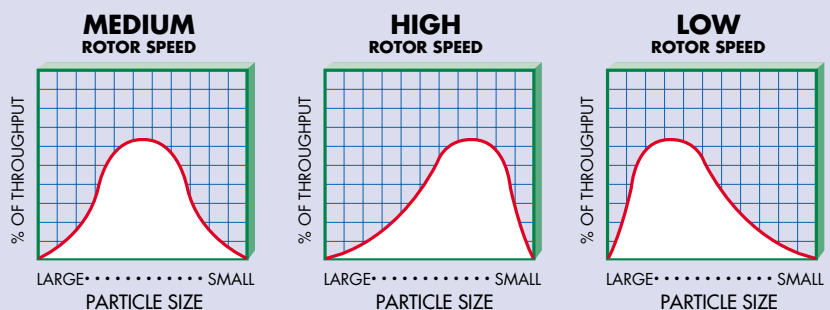

Fig. B

**HOW ROTOR SPEED AFFECTS PARTICLE SIZE**



# THE FITZMILL®

## QUALITY BEGINS WITH THE FITZMILL CHAMBER

At the heart of every FitzMill is the comminuting chamber. Fabricated from stainless steel or special alloys, it houses the rotor, blades and screen. FitzMills are engineered to make the chamber accessible for easy cleaning, inspection and maintenance.

## REVERSIBLE ROTOR ENHANCES VERSATILITY AND BLADE LIFE

You can quickly reverse the rotor on many FitzMills, thereby reversing the blade edges to accommodate a different process (i.e., switch from the knife to the impact edge). Where both edges are identical, reversibility can effectively double blade life.



## EASY TO CLEAN AND MAINTAIN

Save time and expense. A FitzMill disassembles quickly for fast, easy cleaning. Minimal routine maintenance is all that's needed for years of trouble-free service.

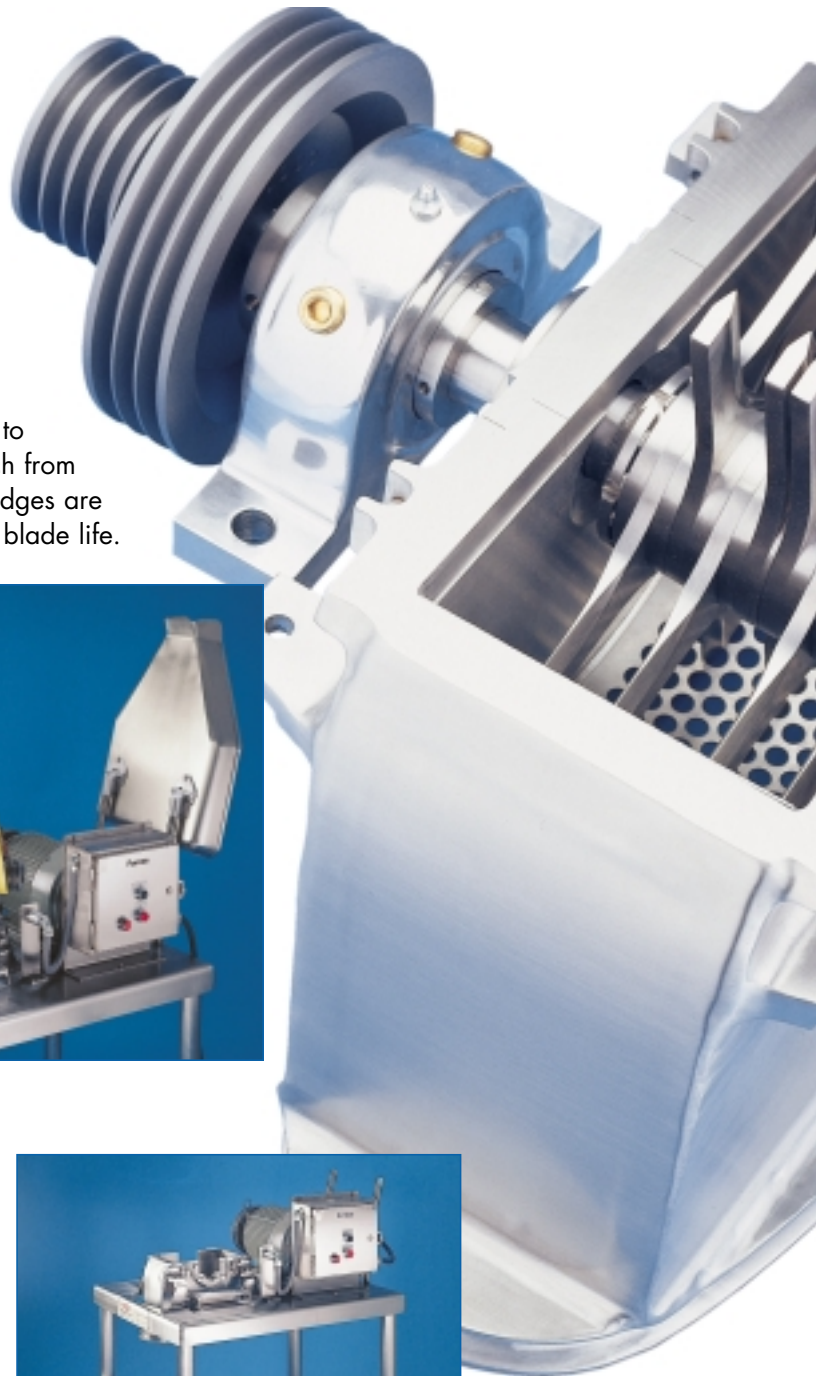

## SAFETY FEATURES PROTECT PERSONNEL

The entire machine can be shielded for noise attenuation. Moving parts, such as flywheels and belts, are fully-enclosed in guards. A safety interlock prevents the machine from being activated when rotor and blades are exposed. Feed and discharge openings feature protective grid bars that discourage milling chamber access while the machine is operating. Where grid bars in the feed opening are not practical, a special reverse-S design feed throat can be provided. The reverse-S can prevent access to the rotor blades without obstruction to product entry.

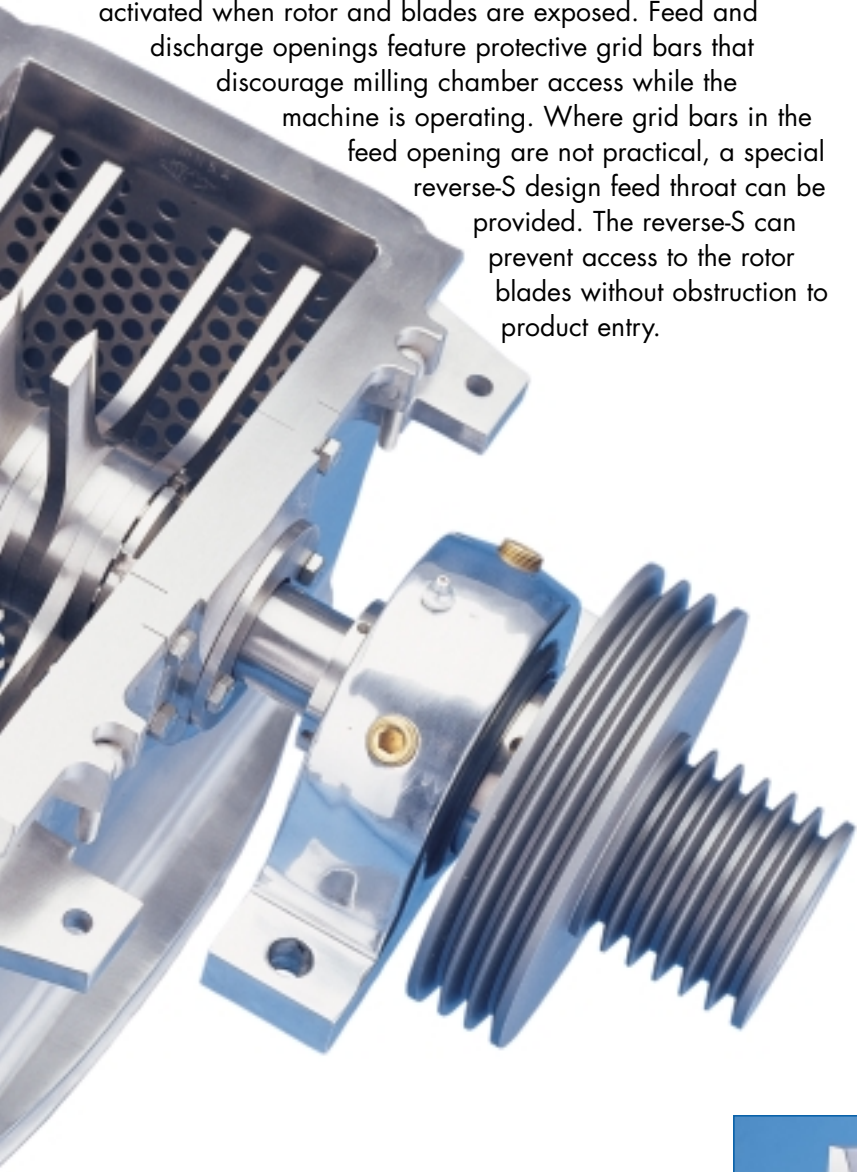

## MOTORS AND CONTROLS FOR EVERY APPLICATION

Drive motors are available for virtually every worldwide electrical standard, for variable or single speed operation, and with special service and temperature ratings including explosion-proof, washdown and TEFC. Convenient, customized controls can be provided either machine-mounted, remotely-mounted, or in a mobile enclosure.



# FITZMILL® COMMINUTORS

## FOR SMALL, MEDIUM OR LARGE SCALE PRODUCTION

### TYPICAL APPLICATIONS

- Coarse grinding and chopping of dry material
- Size reduction of wet material
- De-lumping of agglomerated material, wet and dry
- Pulverizing
- Solid/liquid blending
- Granulating compacted material
- Processing slurries and liquids
- Processing and conditioning wet and dry materials
- Pureeing and emulsifying

### THERE'S A FITZMILL FOR YOUR APPLICATION AND ALL THE HELP YOU'LL NEED TO SPECIFY IT

Achieving your particle size requirements begins with application testing in one of Fitzpatrick's laboratory facilities. Every effort will be made to duplicate your exact production conditions to assure reliable test results. Test data will be used by your Fitzpatrick sales engineer to determine the best FitzMill configuration for your processing needs.



### S-DAS06

This manually-fed, belt-driven Model D features a standard throat, is available with reversible rotor, and can be furnished with a selection of blades and screens to meet any application need.



THE FITZMILLS SHOWN ON THESE PAGES REPRESENT ONLY A FEW MODELS OUT OF HUNDREDS OF CONFIGURATION POSSIBILITIES.



**VFS-DAS06**

The feed system on a Variable Feed Screw (VFS) FitzMill Comminutor is constructed of all stainless steel with disassembly and cleaning in mind. The VFS System provides greater efficiency when grinding to finer particle sizes.



**VFS-FAS020**



This **SPV-FAS020** incorporates a shroud for sound attenuation. The panels are constructed of stainless steel outer shells with lightweight, sound attenuating pads made of F.D.A.-approved materials. The shroud is made with removable panels for easy cleaning and maintenance.



**SPV-FAS020**

FitzMill Comminutors supplied with SPV, open type, feed throats are designed to accommodate special installation requirements.



**SPV-HAS030**



**SPV-DKAS012**

# FITZMILL® SCREENS

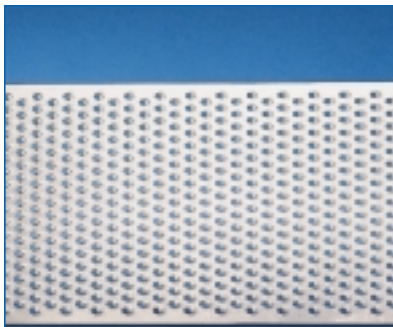

Rasping Screen



Round Hole Perforated

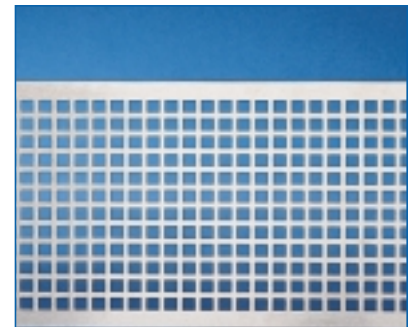

Square Hole Perforated

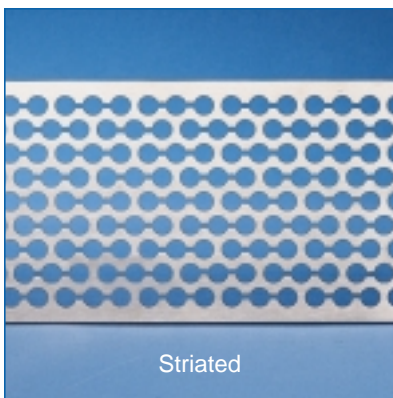
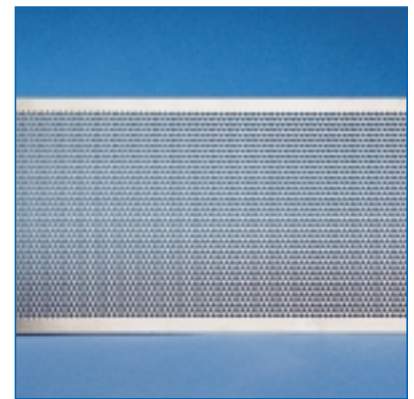
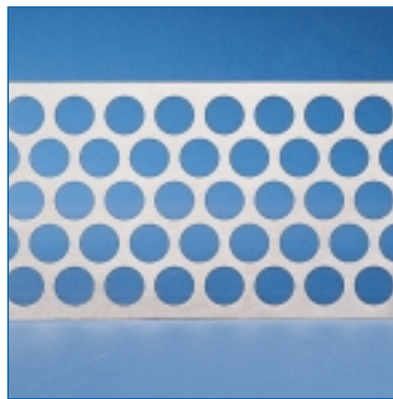

Striated

A complete selection of screen types and sizes is available to produce the particle sizes you require. Screen openings generally vary from 0.30mm (.012") to 38mm (1.5") with round or square perforations, diagonal or straight slots, or with a rasping surface. Special fabrication techniques assure long service life. Screen construction is often customized to meet specific customer requirements. Your Fitzpatrick sales engineer can help you make the right selection.



# FITZMILL® BLADES AND ROTOR ASSEMBLIES



## OVERVIEW

Proper blade style selection is important to assure the desired particle size. When pureeing or pulverizing, impact edges are preferred. When sizing, chopping or granulating, knife edges are usually best. When both processes are used, blades featuring a knife and blunt edge are available.

Fixed or removable tip blade assemblies are offered. Fixed blades feature one-piece construction and simply slide onto a spline to create a complete rotor assembly. Removable tip blades feature a shank that slides onto the rotor. A blade tip is then bolted to the shank. Using either system, blades are positioned on the spline to create the most efficient cutting or impacting pattern.

## BLADES FOR ABRASIVE PRODUCTS

Wear-resistant inserts and coatings can be applied to many blade styles to extend their life in abrasive applications. Fitzpatrick's removable tip blades enable replacement of worn tips without disassembling the rotor.

## BLADES FOR USDA

Special gasketing can be provided between blades to meet USDA 3A guidelines.



## BAR ROTOR

A bar rotor can be supplied when the most gentle form of reduction or de-lumping is required.

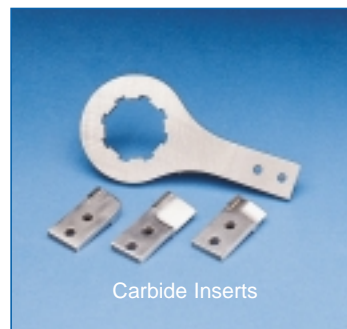
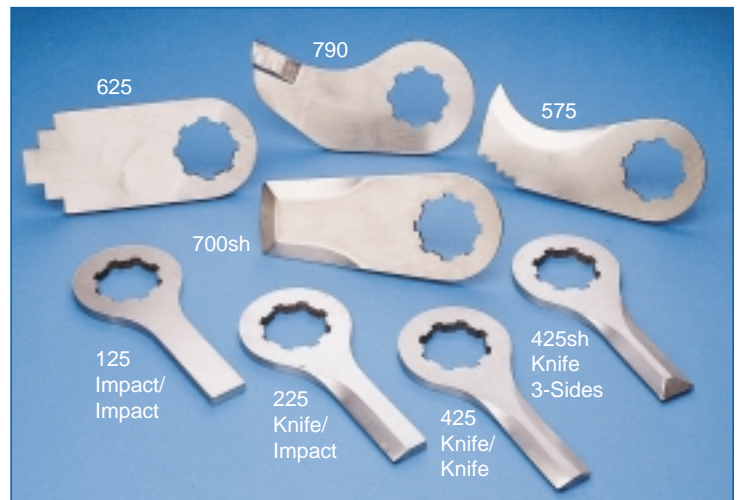

Removable tip blades for abrasive products

# FEED THROATS

Selecting the proper feed throat for your FitzMill comminutor will partially determine the blade force and action imposed upon feed material, thereby affecting particle size.

Inlet location on the feed throat affects particle size distribution. A horizontally situated inlet exposes product to more break-up surface area, producing a finer grind. The addition of breaker bars on inner surfaces of a feed throat produce yet finer grinds. A forward, vertical inlet minimizes break-up and immediately exposes more material to the screen yielding larger-sized particles.

A wide range of interchangeable feed throats is available to optimize your FitzMill's versatility.

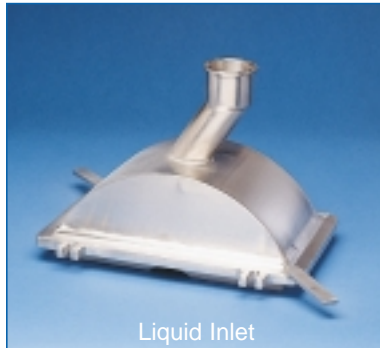

## VARIABLE FEED SCREW (VFS) SYSTEM

Overfeeding can cause unpredictable results; starving can produce a wider-than-desired range of particle sizes. The FitzMill can be built with a variable feed screw (VFS) option to assure precisely controlled feed rate. A VFS helps minimize waste, eliminates operator variables, and achieves particle uniformity. It is also preferred when finer grinding is required.

# MACHINE SPECIFICATIONS

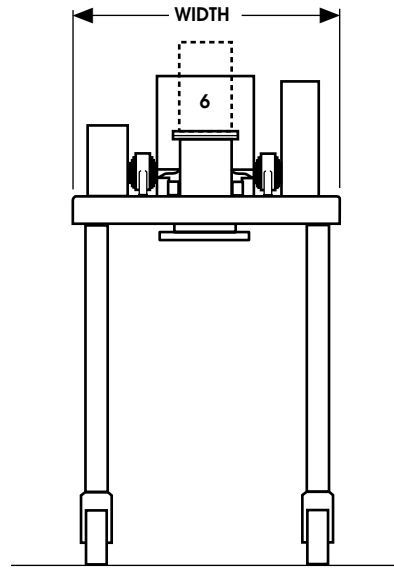
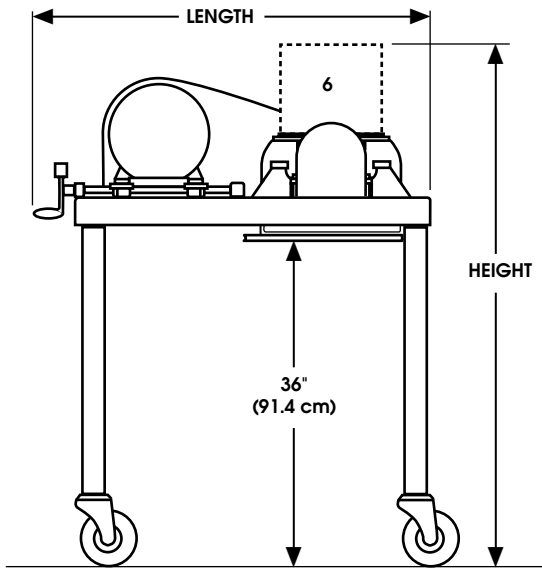

MODEL	CHAMBER			ROTOR		MACHINE LIMITS			APPROX. DIMENSIONS <sup>5</sup>		
	CAPACITY FACTOR <sup>1</sup>	NOMINAL WIDTH	SCREEN AREA	DIAMETER	NUMBER OF BLADES	TIP SPEED FACTOR <sup>2</sup>	MAXIMUM RPM <sup>3</sup>	MAXIMUM HORSE POWER <sup>4</sup>	LENGTH	WIDTH	HEIGHT <sup>6</sup>
L1A	.07	1 in	8.5 in <sup>2</sup>	5.4 in	8	1.42	9,000	.5	18.5	15.4 in.	20 in
		2.54 cm.	55 cm <sup>2</sup>	13.7 cm					46 cm	40 cm	50 mm
Homoloid	0.4	2.5	43	6.625	12	1.73	7,200	10.0	38	30	52
		6.3	277	16.8					.96	.76	1.32
M5A	0.7	4.5	76	8.0	16	2.09	6,100	3.0	32	26	55
		11.4	490	20.32					.81	.66	1.39
D6A	1.0	6	109	10.5	16	2.75	7,200	5.0	35	31	63
		15.24	703	26.67					.89	.78	1.60
DAS06	1.0	6	109	10.5	16	2.75	7,200 (DK) 9,000	15	42	30	66
		15.24	703	26.67					1.07	.76	1.68
DKAS012	2.36	12	257	10.5	32	2.75	6,000	30	48	32	66
		30.48	1658	26.67					1.22	.81	1.68
FAS08	1.83	8	199	14.375	16	3.70	6,800	40	60	36	72
		20.32	1284	36.51					1.52	.91	1.83
FAS012	2.83	12	309	14.375	24	3.70	6,000	75	60	36	72
		30.48	1994	36.51					1.52	.91	1.83
FAS020	4.85	20	529	14.375	48	3.70	3,000	75	60	44	72
		50.80	3412	36.51					1.52	1.12	1.83
FHAS020	4.85	20	529	14.375	48	3.70	3,600	75	60	44	72
		50.80	3412	36.51					1.52	1.12	1.83
HAS030	9.05	30	986	17.25	80	4.45	2,400	150	68	60	75
		76.20	6361	43.82					1.73	1.52	1.90

1. Throughput relative to Model D-6 at same Tip Speed
2. Tip Speed = factor x operating speed
3. With type 125, 225 or 425 blades
4. With V-belt drive at maximum R.P.M.
5. With typical throat and 36" (91.4 cm) between chamber discharge and floor
6. Consult with your Fitzpatrick Sales Engineer for proper throat selection

# THE FITZPATRICK COMPANY

## THE INNOVATION LEADER IN PARTICLE FORMING TECHNOLOGY

We have been solving particle size reduction problems for over 65 years. We're confident we can solve yours.

- Our worldwide organization is strengthened by experienced people and full-service capabilities.
- We can test your products in our laboratories to establish the best equipment configuration to achieve desired specifications.
- If special processing considerations are encountered, our engineers can custom design a FitzMill to meet your needs.
- As a FitzMill owner, you'll be backed by a team of technicians and service experts whose mission is to keep your equipment on-line and productive.

### OTHER FITZPATRICK PRODUCTS:

The **FitzAire**<sup>®</sup> fluid bed dryer

The **Malaxator**<sup>®</sup> continuous blender-heat processor

**Guiloriver**<sup>®</sup> and **Guilocutter**<sup>®</sup> pre-breaking equipment

The **Chilsonator**<sup>®</sup> roll compactor size enlarger



**FITZMILL**

**THE FITZPATRICK COMPANY**

**FITZMILL**

### CORPORATE HEADQUARTERS

832 Industrial Drive  
Elmhurst, IL 60126 USA  
Phone: 630-530-3333  
Fax: 630-530-0832  
E-mail: [info@fitzmill.com](mailto:info@fitzmill.com)

### EASTERN U.S. DIVISION

4219 S. Clinton Ave.  
South Plainfield, NJ 07080 USA  
Phone: 908-561-1500  
Fax: 908-561-9636  
E-mail: [info\\_nj@fitzmill.com](mailto:info_nj@fitzmill.com)

### FITZPATRICK EUROPE N.V.

Entrepotstraat 8  
B-9100 Sint-Niklaas, Belgium  
Phone: +32 (0)3 7806200  
Fax: +32 (0)3 7661084  
E-mail: [info@fitzpatrick.be](mailto:info@fitzpatrick.be)

Visit us on our web sites : [www.fitzmill.com](http://www.fitzmill.com)  
For Europe: [www.fitzpatrick.be](http://www.fitzpatrick.be)