



# CORNELL PUMP COMPANY

## Refrigerant Pump 1.5CBH

### PUMP SPECIFICATION

- 1.5CBH Close coupled refrigerant pump
- 4" x 1.5" Class 150 Flanged suction & discharge
- Constructed of ASTM A536 60-40-18 Ductile Iron
- Industry leading two year warranty
- Four pole (1800/1500RPM) operating speed
- Optional mounting configurations available
- Polar white
- **Mechanical Seal:**  
John Crane, 1.25", T-1, double mechanical shaft seal with pressurized barrier fluid lubrication system, low oil limit switch, and seal chamber heater to maintain proper barrier oil viscosity
- **Motor Specification:**  
Close coupled to a totally enclosed fan cooled, refrigerant atmosphere, hostile environment, premium efficiency motor, with class "F" installation; suitable for VFD applications



### FEATURES & BENEFITS

- **Refrigerant Emission Free™ Sealing Technology**
  - an ultra-reliable system consisting of two mechanical seals mounted back to back
  - inboard seal prevents escape of refrigerant from the pump casing
  - outboard seal acts as a fail-safe or backup, and provides containment of a system compatible barrier fluid.
- **NPSHR**
  - exceptional NPSHR characteristics
  - characteristics are enhanced throughout entire operating range due to the single stage impeller and four pole operating speed
- **Vapor Entrainment**
  - seals are oil lubricated, and do not rely on the presence of pumpage for lubrication or cooling
  - the double mechanical sealing system allows the pump to continue to run until the system stabilizes and the pump reprimers itself - nuisance-tripping is avoided

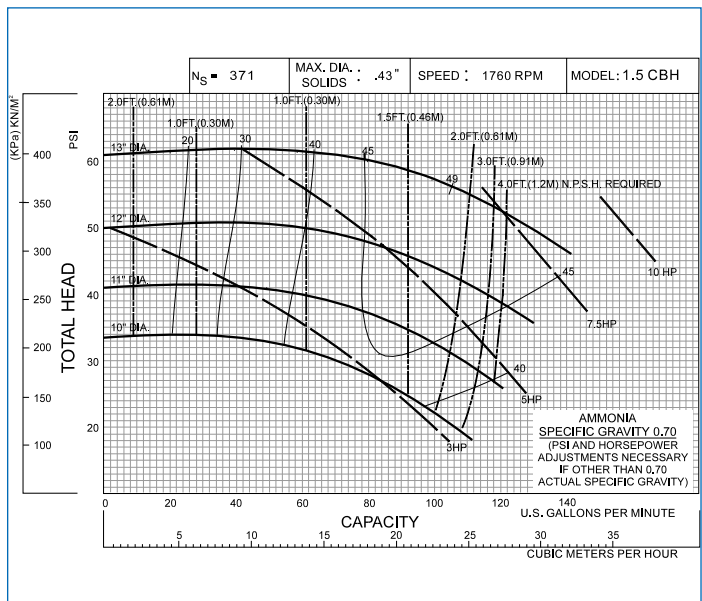

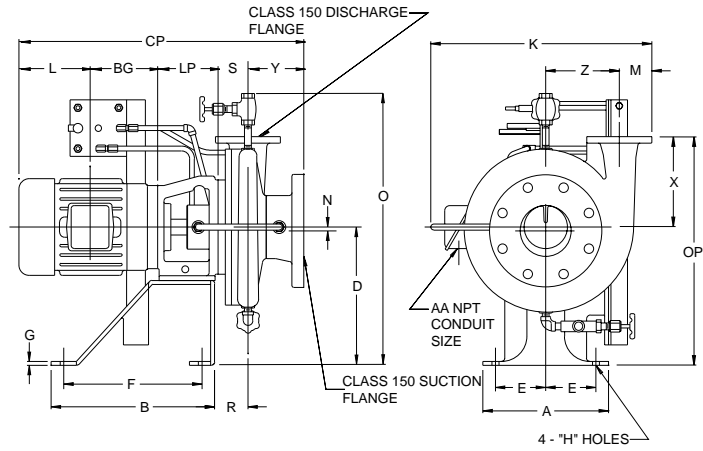

## PUMP DIMENSIONS

Model	NEMA Frame	Disch.	Suct.	Type	A	B	D	E	F	G	H	K	M	N	O	R	S	X	Y	Z	LP	OP
1.5CBH	182-184	1.50	4.0	FLG.	10.0	13.0	11.06	4.0	11.0	0.31	0.56	20.50	2.50	0.50	26.62	3.02	1.88	8.00	4.75	7.00	5.38	19.06

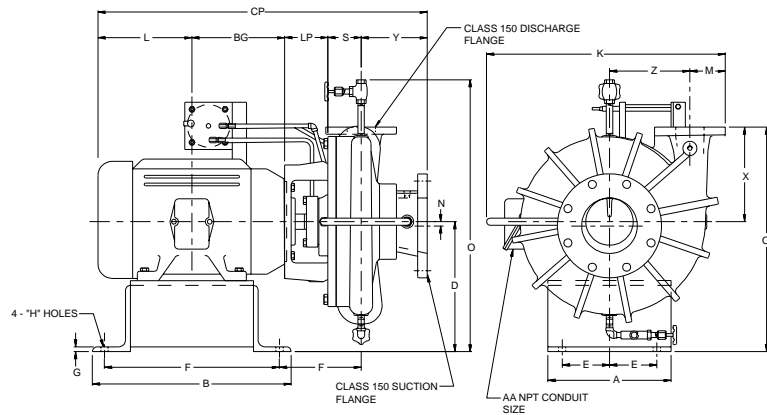

## PUMP DIMENSIONS

Model	NEMA Frame	CONNECTION			A	B	D	E	F	G	H	J	K	M	N	O	R	S	X	Y	Z	LP	OP
		Disch.	Suct.	Type																			
1.5CBH	213-215	1.50	4.0	FLG.	13.0	21.0	12.75	5.0	18.50	0.50	0.75	1.25	20.50	2.50	0.50	28.31	6.00	1.88	8.00	4.75	7.00	5.38	19.06

## MOTOR DIMENSIONS

HORSEPOWER 1800 RPM	NEMA Frame	L	BG	AA	See Note No. 3
3.0 - 5.0	182	7.69	6.25	0.75	CP=
3.0 - 5.0	184	7.69	6.25	0.75	CP=
7.50	213	8.81	8.00	1.00	CP=
10.00	215	8.81	8.00	1.00	CP=

**Notes:**

1. Motor dimensions are TEFC NEMA Standard
2. Motor dimensions are based on Baldor electric motors; motor dimensions L, BG, & AA may vary for other manufacturers.
3. Dimension "CP" to be filled in after selection of pump and motor.

**Cornell Pump Company**  
 P.O. Box 6334  
 Portland, Oregon 97228-6334  
 Web: [www.cornellpump.com](http://www.cornellpump.com)  
 Phone (503) 653-0330 • Fax (503) 653-0338

**ISO9001** CERTIFIED