

Label Applicators

Where labeling begins.



L30

- Wipe on label applicator
- Clutch brake driven
- Variable speed
- Optional start and stop delay



L15H

- Wipe on label applicator
- Clutch brake driven
- Variable speed
- Start delay and stop delay standard

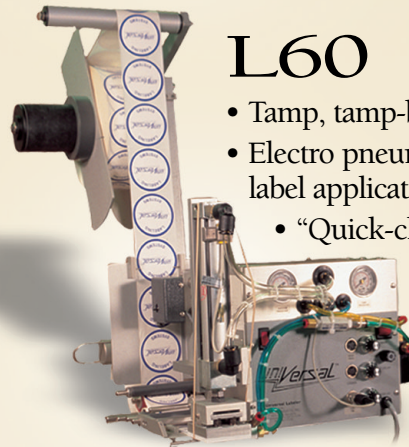

L60

- Tamp, tamp-blow or blow-on
- Electro pneumatic operated label applicator
- “Quick-change” tamp heads



SL1000

- Wipe on label applicator
- Stepper driven
- Photoelectric label sensing



SL2000

- Wipe on, tamp, tamp blow or blow-on
- High-speed stepper driven label applicator
- Photoelectric label sensing
- Digital Operator interface

UNIVERSAL[®]
LABELING SYSTEMS, INC.

Engineering
labeling solutions.

SPECIFICATIONS

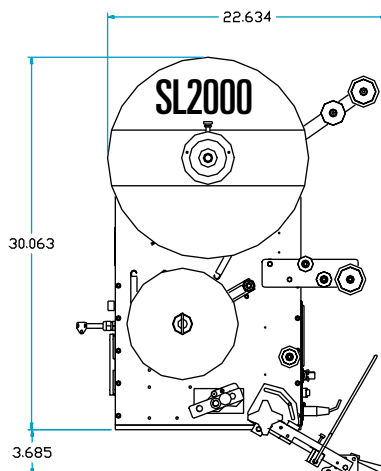
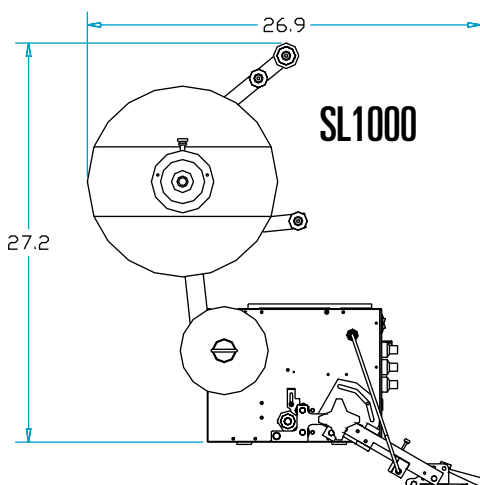
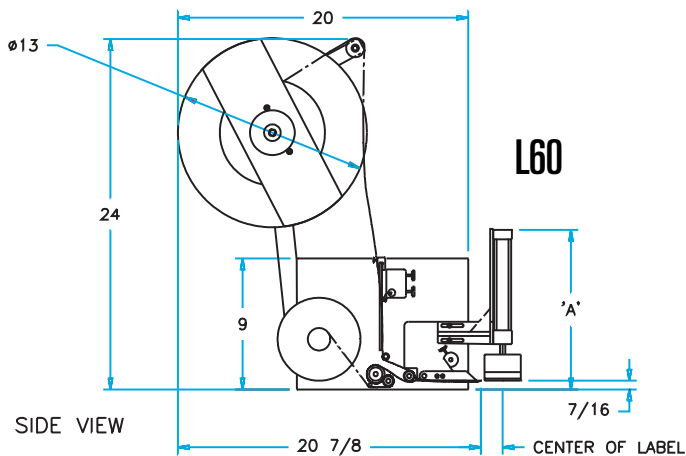
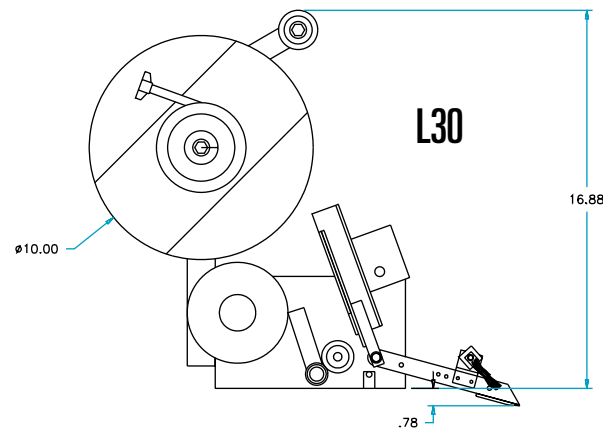
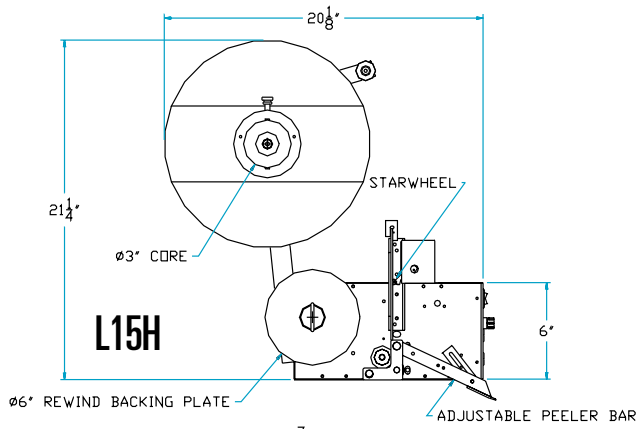

L15H

- Dimensions: 19 1/2" W x 21" D x 22 1/2" H
- Label dispense speed: up to 1200" per min.
- Web width: up to 4 1/2"
- Label roll capacity: up to 12"Ø
- Electric: 120 VAC =+/-10%

L30

- Dimensions: 14 1/4" W x 20 1/2" D x 18" H
- Label dispense speed: up to 700" per min.
- Web width: up to 2 1/8"
- Label roll capacity: up to 10"Ø
- Electric: 120 VAC =+/-10%

L60

- Dimensions: 19" W x 23" D x 24 3/4" H
- Label dispense speed: 529" per min. (fixed)
- Web width: up to 4 1/2"
- Label roll capacity: up to 12"Ø
- Electric: 120 VAC =+/-10%
- Air: 40 PSI Tamp/80 PSI blow-on

SL1000

- Dimensions: 20 1/2" W x 27" D x 30" H
- Label dispense speed: up to 1200" per min.
- Web width: up to 6 3/8"
- Label roll capacity: up to 12"Ø
- Electric: 120 VAC =+/-10%

SL2000

- Dimensions: 19 1/2" W x 22" D x 33 3/4" H
- Label dispense speed: up to 3000" per min.
- Web width: up to 6 3/8"
- Label roll capacity: up to 16"Ø
- Electric: 120 VAC =+/-10%
- Air: 40 PSI Tamp/80 PSI blow-on

**Universal
Labeling Systems, Inc.**
3501 8th Avenue South
St. Petersburg, FL 33711
1-877-236-0266
sales@universal1.com
www.universal1.com