

931374-8

NOTES : 1. RIGHT-HAND UNIT SHOWN  
(LEFT HAND OPPOSITE)  
2. THREE PHASE MOTORS

DRAW THRU-4 FAN UNIT

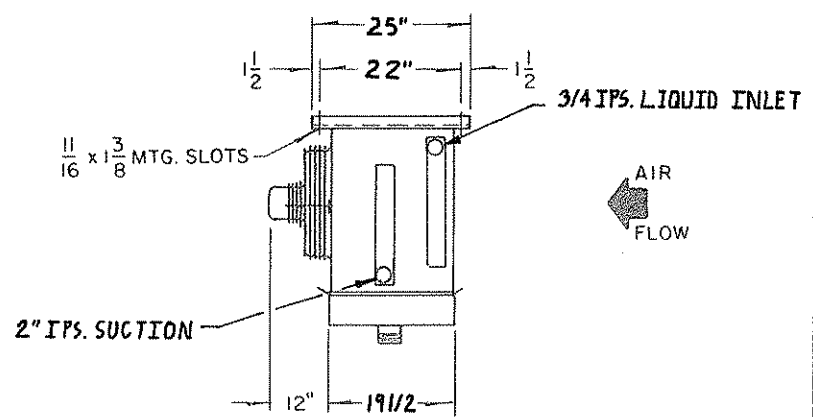
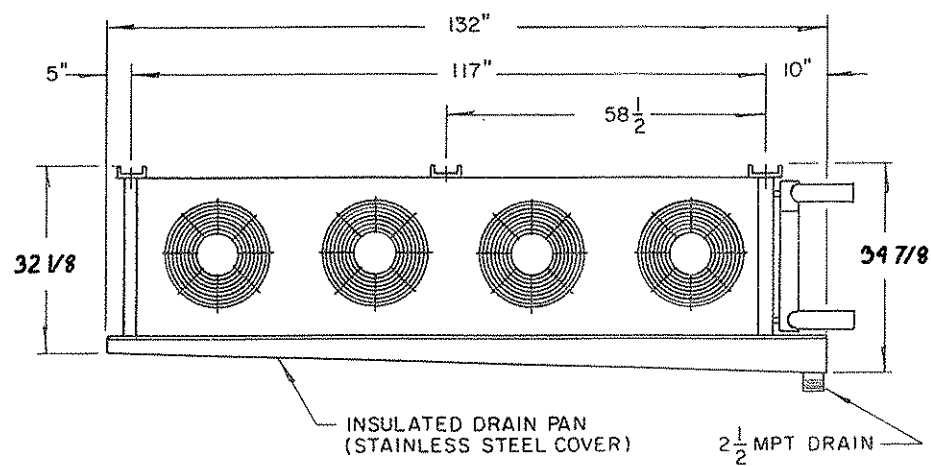

CAPACITY - 10.5 TONS AT 15 °FTD @ 35 °FET  
 REFRIG - PUMP RECIRC. NH<sub>3</sub> (2:1 RATIO)  
 DEFROST - AIR  
 COIL - STEEL TUBE & FIN (H.D.G.)  
 CHARGE - 1.88 CU. FT INT VOL.  
 AIR FLOW - 13,840 CFM  
 FAN - (4) 22" DIA PROP TYPE  
 MOTOR - (4) 1/3 HP 1140 RPM 230/60/3

\*\*  
 QUANTITY - 1 R.H. / 1 L.H. UNITS  
 NET WEIGHT - 1560 LBS.  
 CUSTOMER - RECO  
 JOB - HUDSON FARMS  
 LOCATION - SPRINGFIELD, MO.  
 APPROVED BY - \_\_\_\_\_ DATE \_\_\_\_\_  
 MARK - \_\_\_\_\_

DO NOT SCALE PRINT  
 WORK TO DIMENSIONS

ALL DIMENSIONS ARE OUTSIDE  
 UNLESS OTHERWISE SPECIFIED

		CUSTOMER PO <u>34862</u>	
		S.O. <u>31374H</u>	ITEM <u>8</u> OF <u>8</u>
		DATE <u>7-21-89</u>	SCALE NONE
		DRAWN BY <u>H.C.</u>	CHK'D BY _____
			APR'D BY _____
TITLE			
UNIT COOLER			
NO. _____		REVISIONS	
NO. _____		DATE APR V D	
Frigid Coil		MODEL SERIES - <u>400</u>	DRAWING NO
SANTA FE SPRING, ILL. U.S.A. 60050		<u>HT3-464-1/3-LRT-IP</u>	<u>931374-8</u>
			REV