

Alleghen Bradford Corp Processor

Mfg: Alleghen Bradford Corp

Model:

Stock No. OI95

Serial No.

Alleghen Bradford Corp Processor, National Board No. 198. MAWP: 25 FVPSI at 200 °F. MDMT: -20 °F. at 25 FV PSI, S/N 6638-03. Year built: 1993. Pressure transmitter: Setra, Model C290, S/N 368235. Range 0-2 PSIG, Supply 24 DC. Output: 4020, Inlets: (4) 2 in., 1-½ in., 1 in. and 1 in., 13-½ in. diameter manhole (w/1x3 in. inlets on top of manhole). Outlet 2 in. (4) Legs 20 in. H. Inside dimensions 34 in. diameter. 57-½ in. H.



SYM	SIZE & TYPE
A	2" TRI-CLAMP
B	14" HINGED MANWAY
C	2" TRI-CLAMP
D	1 1/2" TRI-CLAMP
E	1" TRI-CLAMP
F	1 1/2" TRI-CLAMP
G	2" TRI-CLAMP
H	2 1/2" TRI-CLAMP
I	3" TRI-CLAMP

TOP VIEW

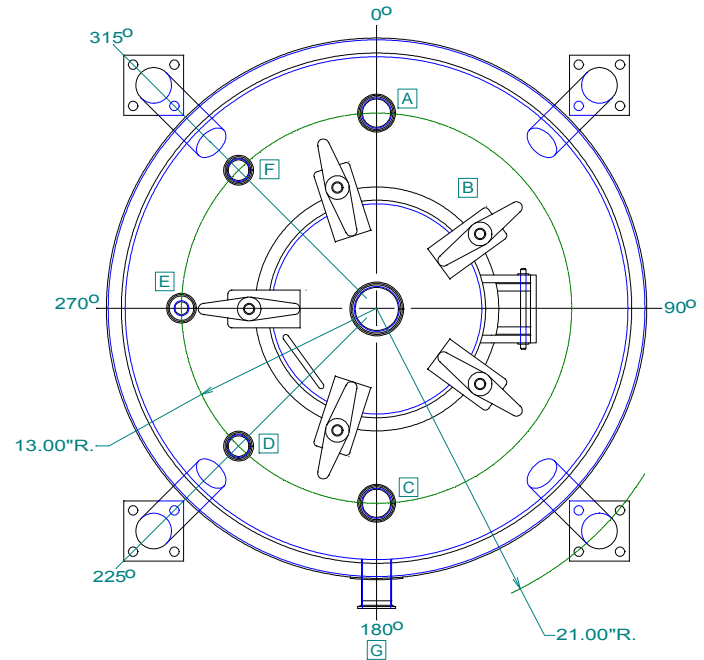

NOTES:

- 1) MATERIAL: PRODUCT CONTACT-316L S/S
NON-WETTED SURFACES-304 S/S
- 2) FINISH: INTERNAL-<25 RA & ELECTROPOLISHED
EXTERNAL-150 GRIT, WELDS GROUND SMOOTH & BLENDED
- 3) ASME "U" CODED & NATIONAL BOARD REGISTERED FOR:
25 PSIG & FULL VACUUM @ 200°F.



TITLE: JOHN KALOYANIDES & ASSOC.
150 GALLON TANK

TOLERANCES	DWN BY: M.A. SUTHERLAND	CKD. BY: J.L. VECELLIO
DECIMALS:	DATE: AUG. 28, 1992	DATE: AUG. 31, 1992
.XX ±.12	DWG.# F579400	REV.# C
.XXX ±.060	CDN.# 355	SHEET# 1 OF 4
ANGLES ±1°		

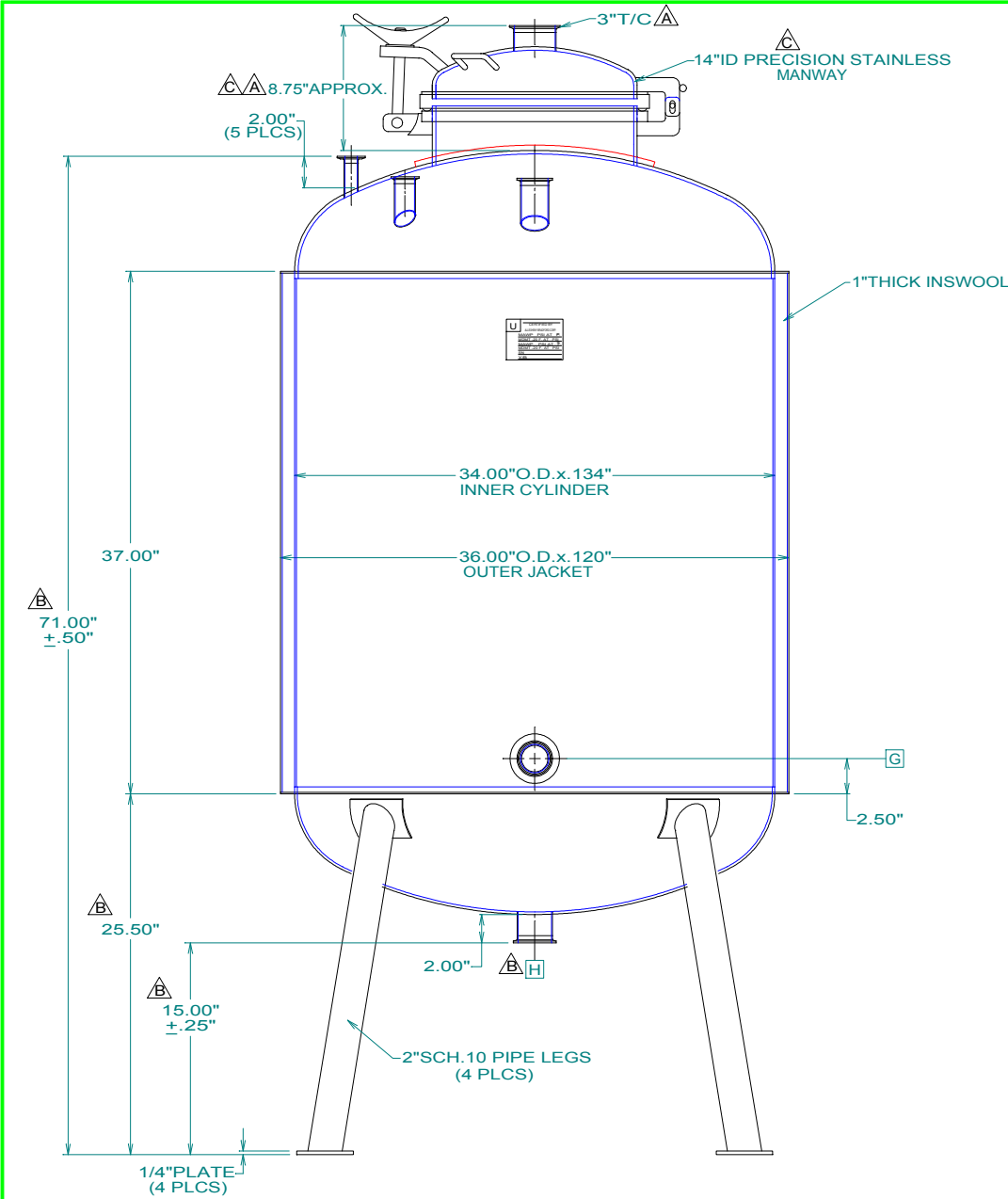

SYM.	CORRECTIONS	DATE	CHK.
C	CHANGED MANWAY TO 14"PRECISION	10/5/92	
B	NOZZLE "H" & LEG DIM. CHANGED	9/24/92	JLV
A	MANWAY MOVED & ADDED NOZZLE "I"	9/17/92	JLV
	-REVISIONS-		