

BURFORD CORP.®

SERVICE MANUAL

FOR YOUR

BURFORD

APPLICATOR

Model 8830 (Station #1)

Model # _____

Serial # _____

Wiring Diagram # _____ Issue _____

DATE: August 8, 2006

COPYRIGHT © 2006 by BURFORD CORP.

MANUAL PART No. SO47572 ISSUE "B"

DISCLAIMER

The descriptions contained in this Service Manual were in effect at the time this manual was approved for printing. Our policy is one of continuous improvement, and we do hereby reserve the right to discontinue models at any time, or to change specifications, prices, or designs without notice and without incurring obligations.

Burford Corp. expressly disclaims any liability for damages and/or injuries caused as a result of negligence or misuse of its product. Such negligence or misuse includes, but is not limited to the removal of guards, or faulty wiring due to improper installation.

NOTICE:

As Burford Corp. strives to promote safety in the maintenance and operation of Burford equipment, we request that the following safety procedures be followed, along with any additional safety procedures set by the customer's in-plant safety officers or local codes.

- 1. Read operation manual completely before attempting installation or operation of unit.**
- 2. Incoming electrical power must be properly shielded, routed and grounded. All safety codes should be followed. Study wiring diagram before attempting installation.**
- 3. Disconnect power to equipment before removing any guards or covers. Replace guards and covers before resuming operation of unit.**
- 4. Loose clothing and long hair should be considered a safety hazard around mechanical equipment. Ensure that they will not be entangled in the equipment.**
- 5. Do not by-pass safety switches.**
- 6. Do not attempt repairs while equipment is running.**
- 7. Use only original equipment parts designed to safely operate in the equipment.**
- 8. Only authorized personnel should be allowed to operate or perform maintenance on the unit.**
- 9. The equipment should only be used for the purpose for which it was sold and should not be modified in any way without notifying the general manager of Burford Corporation in writing of the modification.**

TABLE OF CONTENTS

DISCLAIMER	ii
NOTICE:	iii
TABLE OF CONTENTS	iv
1.0 GENERAL INFORMATION	1-1
1.1 Introduction	1-1
1.2 Specifications	1-1
1.3 Machine Description	1-1
2.0 THEORY OF OPERATION.....	2-1
2.1 Operation Sequence.....	2-1
3.0 INSTALLATION PROCEDURES	3-1
3.1 Determining the best location to mount on existing conveyor	3-1
3.2 Utility Installation.....	3-1
4.0 USING THE OPERATOR CONTROLS.....	4-1
4.1 Control Panel Description	4-1
4.2 Main Screen Functions	4-2
4.3 Product Tank Temperature Control	4-3
4.4 Control Cabinet.....	4-4
4.4.1 Tank Agitator.....	4-4
5.0 OPERATION PROCEDURES	5-1
5.1 Initial Start-Up	5-1
5.2 Creating a New Recipe.....	5-2
5.3 Spray Rail Set-Up.....	5-3
5.4 Changing Machine Setpoints.....	5-4
5.4.1 Fill Level Setpoints	5-4
5.4.2 Thermocouple Calibration Offset.....	5-4
5.4.3 Pump #1A Setup	5-5
5.4.4 Pump #1B Setup	5-5
5.4.5 Rail Override	5-6
5.4.6 Mix Tank Alarm Setpoints	5-6
5.4.7 Tank Level Sensor Calibration	5-6
5.4.8 Goto Display Configuration Screen	5-7
5.4.9 Spray Position Setup.....	5-7
6.0 SETTINGS AND ADJUSTMENTS	6-1
6.1 Nozzle Height	6-1
6.2 Actuation and Timing Procedures	6-2
6.2.1 Product Sensor	6-2
6.3 Product Flow Rate	6-3
6.4 Product Tank Level Sensor	6-4
7.0 PUMP MOTOR DRIVE	7-1
7.1 Pump Motor Drive Settings.....	7-2
8.0 MAINTANENCE AND SERVICE PROCEDURES.....	8-1
8.1 Filling the Product Tank Water Jacket.....	8-1
8.2 Restoring Product Flow	8-2
8.3 Changing the Product Filter	8-3
8.4 Product Pump Seal Maintenance	8-4
9.0 START-UP PROCEDURE.....	9-1
9.1 Start-Up Checklist.....	9-2
9.1.1 Mechanical Setup.....	9-2
9.1.2 Electric	9-2
9.1.3 Pneumatic.....	9-2
9.1.4 Product Lines	9-2
9.1.5 Tank Check	9-3
10.0 CLEANING PROCEDURES	10-1
10.1 Basic Procedure (after each production run).....	10-1
10.2 Cleaning the Manifold Assembly	10-2
10.3 Cleaning the Product Tank and Agitator.....	10-4
10.4 Cleaning the Product Pump.....	10-5
11.0 TROUBLE SHOOTING.....	11-1
11.1 Light Tower Descriptions	11-1
11.2 Set-Up Values.....	11-2
12.0 RECOMMENDED SPARE PARTS	12-1
13.0 PREVENTIVE MAINTENANCE	13-1
14.0 PARTS LISTS / ASSEMBLY DRAWINGS	14-1
14.1 Waukesha Pump Part Identification	14-1
14.2 Waukesha Pump Seal Identification.....	14-4
14.3 Pump System	14-5
14.4 Tank Detail.....	14-6
14.5 Agitator Assembly.....	14-7
14.6 Miscellaneous Part Identification	14-8
14.7 Standard Wiring Diagram	14-10

1.0 GENERAL INFORMATION

1.1 Introduction

The Burford Model 8830 Applicator has been designed to spray a controlled amount of garlic oil into empty pan cavities, without interruption to the pan flow.

The following pages contain installation, operation and maintenance instructions. To ensure maximum performance, these instructions should be followed with care.

1.2 Specifications

1. Air – 2 scfm @ 60 psi
2. Electricity – 208/220-50/60-1 phase @ 30 amps

1.3 Machine Description

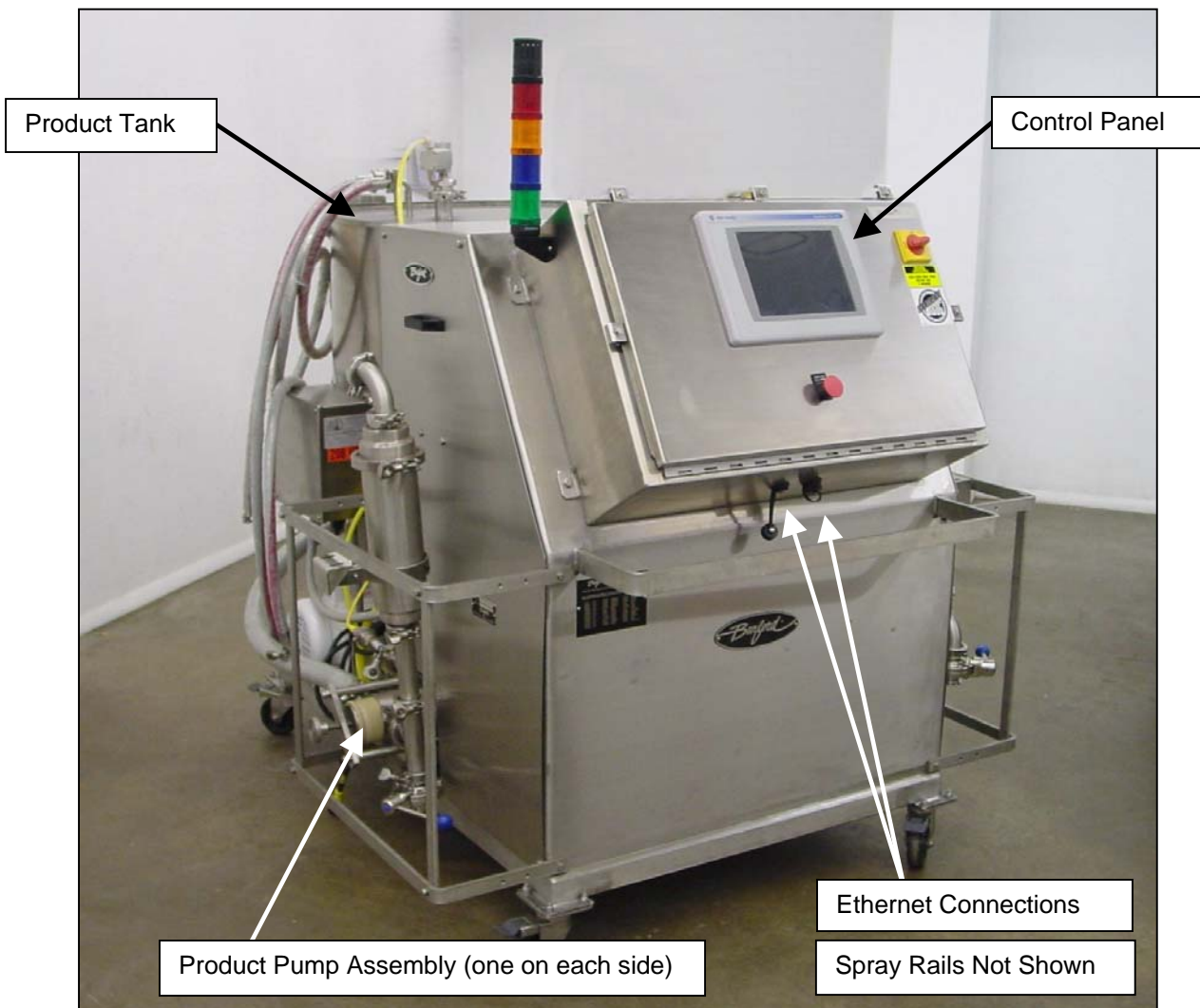

2.0 THEORY OF OPERATION

2.1 Operation Sequence

The unit is designed to supply two spray rail assemblies. Start the conveyor(s), place a pan on it, and allow it to travel toward the unit. It will encounter the spray rail and pan sensor. This sensor will sense the leading edge of the pan and send a signal to the Programmable Logic Controller (PLC) to activate the applicator nozzles to apply garlic oil as each pan passes.

3.0 INSTALLATION PROCEDURES

3.1 Determining the best location to mount on existing conveyor

1. The portion of the conveyor that is to be used should have at least 30 inches of free length.
2. The conveyor sides should be free of any interference from bolts, conduit, motors, shafts, junction boxes, guarding, support members, etc.
3. The underside of the conveyor should also be clear of the interference listed in number two.
4. The top of the conveyor should be of an open style, (opening between conveyor chain) so the actuation switch is free to move from side to side, upstream, and downstream.
5. Pan guides must be used to keep pans straight when traveling through the unit.
6. The conveyor chosen should not allow the pans to stop, turn or back-up during operation.
7. Area around the unit installation should be clear of any obstruction and unit shall not be installed in such a way as to create a safety hazard, or block a normal passageway. Clearance must conform to all local safety codes.
8. Installation site should have ample clearance on operator side for easy access and normal maintenance. Consideration must be made for positioning the tank assembly within 10 feet of installation site.

3.2 Utility Installation

A qualified electrician must make all electrical connections. A suitable circuit must be chosen so the 30 AMP requirement does not overload the total current capacity. A suitable circuit with all safety requirements must comply with local electrical codes.

Once the unit is mounted to the conveyor and the uprights containing the nozzles are in place, the tank assembly can be located next to the conveyor. This should be mounted so the machine operator can have easy access to the controls.

4.0 USING THE OPERATOR CONTROLS

4.1 Control Panel Description

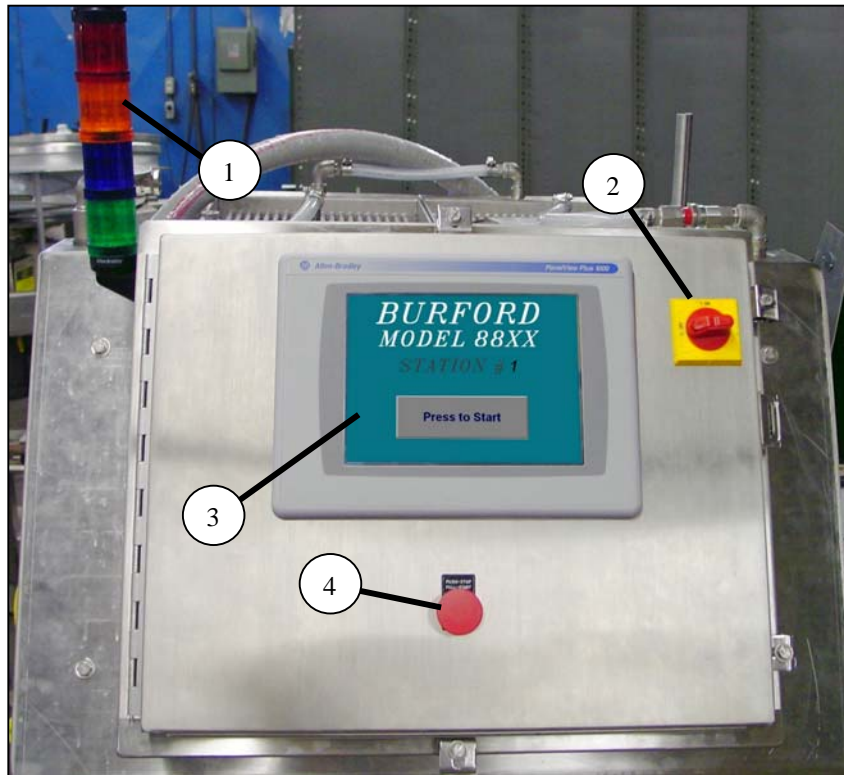

Other than mechanical set-up and manual nozzle spray, the operator control panel controls all functions required to operate the applicator. The functions of the operator control panel are outlined below.

ITEM	DESCRIPTION	FUNCTION
1	Light Tower	Notifies operator of machine status. See Section 11.1 for descriptions.
2	Primary Disconnect	Remove electrical power from unit.
3	Main Display	Displays menu screens, error messages and allows convenient operator interface. Simply touch the screen at the desired function and follow pop-up screen instructions.
4	Start/Stop Button	Removes electrical power from machine components.

4.0 USING THE OPERATOR CONTROLS, cont'd.

4.2 Main Screen Functions

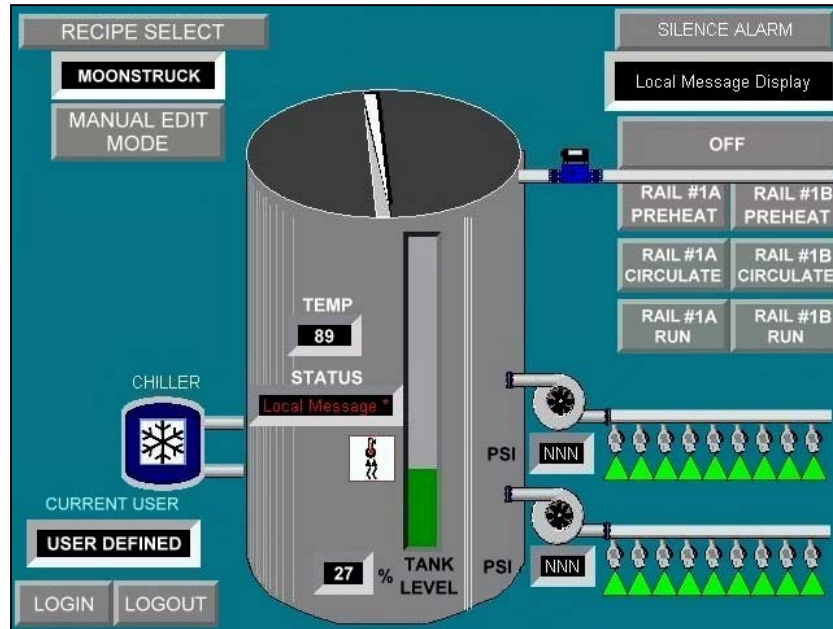

Touch the desired box or icon to access the desired machine function.

DESCRIPTION	FUNCTION
OFF	Turns "OFF" all internal relays and CLEARS the programming registers residing in the Programmable Logic Controller (PLC).
RAIL #1A / RAIL #1B PREHEAT	Turns "ON" the product tank water jacket circulating pumps and initializes the temperature controls. The agitator is also turned "ON" after a 15 second delay timer expires; provided the tank lid (section 6.4) is in place. The product pump and spray nozzle trigger sensor are NOT energized.
RAIL #1A CIRCULATE	Product tank water jacket, agitator and rail #1A product pump are turned "ON". Spray nozzle trigger sensor is NOT energized. Product pump will be at low speed for 10 seconds then switch to normal run speed once proper operating pressure is verified.
RAIL #1B CIRCULATE	Product tank water jacket, agitator and rail #1B product pump are turned "ON". Spray nozzle trigger sensor is NOT energized. Product pump will be at low speed for 10 seconds then switch to normal run speed once proper operating pressure is verified.
RAIL #1A RUN	Same as "CIRCULATE", except rail #1A trigger sensor will activate spray.
RAIL #1B RUN	Same as "CIRCULATE", except rail #1B trigger sensor will activate spray.
LOGIN / LOGOUT	LOGIN allows authorized users to enter their user name and password access to "MANUAL EDIT MODE". LOGOUT returns the unit to "AUTO MODE".
MANUAL EDIT MODE	This mode is password protected and allows the authorized user to create recipes and make additional machine setting changes. NOTE: This box is not shown until an authorized user has completed the "LOGIN" sequence.
Other Functions	Touch desired "ICON" to access additional pop-up screens. Follow pop-up screen instructions. Some individual "ICON" settings are accessible only while in "MANUAL EDIT MODE", which is password protected, see your supervisor.

NOTE: See Section 5 for additional screen information.

4.0 USING THE OPERATOR CONTROLS, cont'd.

4.3 Product Tank Temperature Control

The transfer tank is a double wall design with water being circulated through the outer jacket. The temperature of this water is controlled from the operator panel. The controller will signal the tank heater or tank chiller to maintain the temperature setting. The temperature range for this controller is 65° – 135° F. The controller should be set to maintain the desired product consistency. A hand-held thermometer will be required to measure actual product temperature.

1. Touch the mix tank temp “ICON” to access the “SET TEMP” pop-up screen.

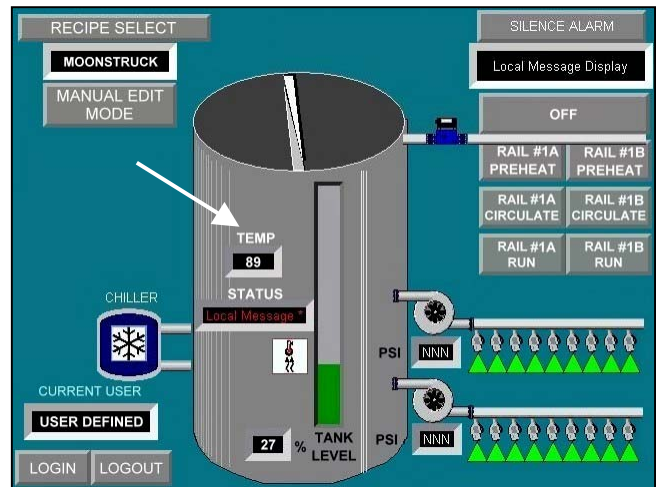

2. Touch the “SET TEMP” box to modify temperature setting. To turn the tank chiller and tank heater “OFF” or “ON”, touch the respective “ICON” (see arrows) and follow pop-up screen instructions.

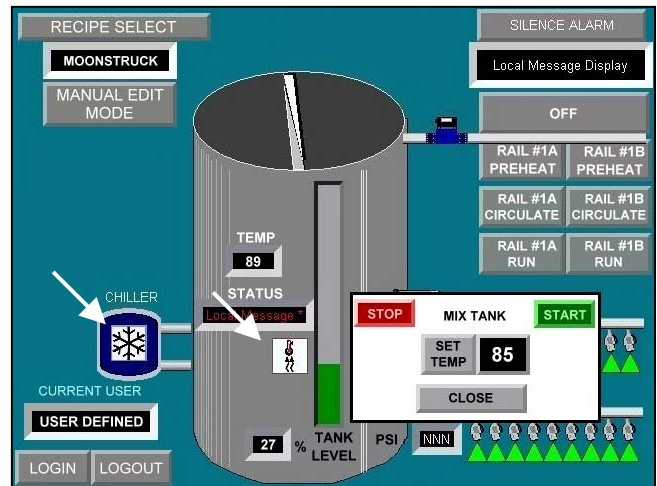

NOTE: This value is the temperature of the circulating water in the tank water jacket, NOT the actual product temperature.

4.4 Control Cabinet

The control cabinet houses the product tank chiller, product pumps and other electrical components.

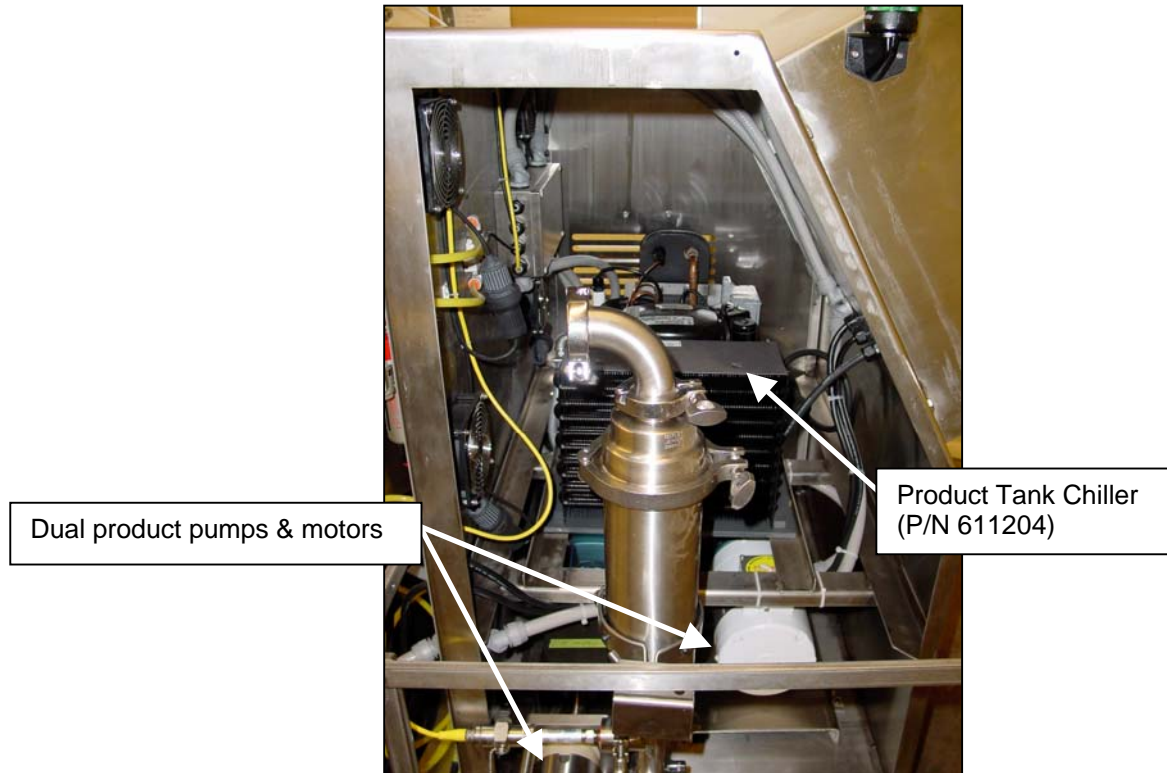

4.4.1 Tank Agitator

The product tank is equipped with an agitator to keep the garlic oil in constant motion, in order to maintain smooth product consistency. The agitator also aids in tank clean out by “wiping” the tank walls with each revolution.

The agitator is only operational when activated via the touchscreen display on the operator control panel.

NOTE: Agitator will automatically shutdown when access lid is removed.

5.0 OPERATION PROCEDURES

5.1 Initial Start-Up

1. Turn on electrical power via the main enclosure disconnect switch. Verify the red “START/STOP” button is in the out position to initiate machine operation. Close the appropriate isolation valve(s) and check that all hoses are securely connected. The following screen will be shown on the operator display.

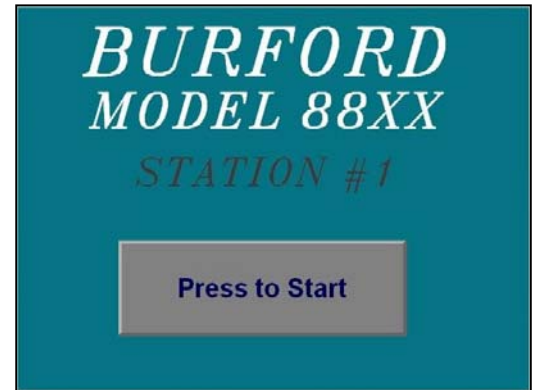

2. Once unit has completed the set-up sequence, the “MAIN MENU” screen will be displayed. Verify the correct recipe is displayed, if not; touch the “RECIPE SELECT” button and highlight the desired recipe, then press “enter”. Touch one of the “PREHEAT” buttons to bring the garlic oil up to the preset temperature. Verify the agitator is free from any obstruction and the backpressure regulator adjustment screw is backed out to minimize pressure.

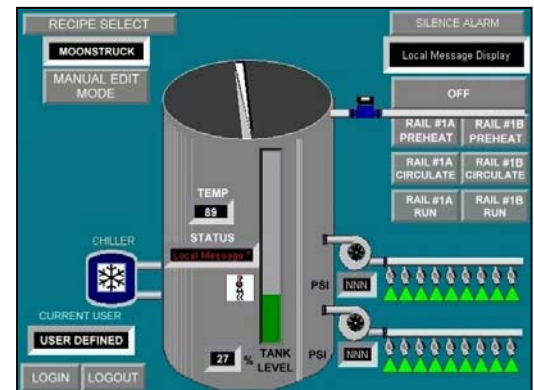

3. Once garlic oil is of desired consistency inside product tank, open the appropriate isolation valve(s) and verify garlic oil has completely filled infeed hose(s). Touch the necessary “CIRCULATE” function for the desired spray rail and allow the product to completely fill the system and circulate for 10 minutes. Verify spray nozzle operation by touching the desired spray rail icon and activating the “PURGE” or “SPRAY”. Adjust the backpressure regulator and pump pressure to give the desired output quantity.

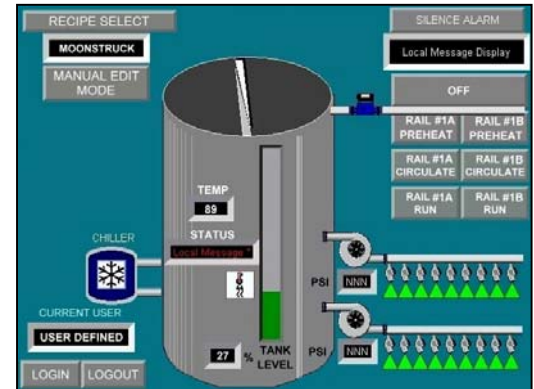

4. Touch the desired “RUN” function once satisfied with machine operation.

5. Begin production operation.

NOTE: See section 6.1 for identification of spray rail components.

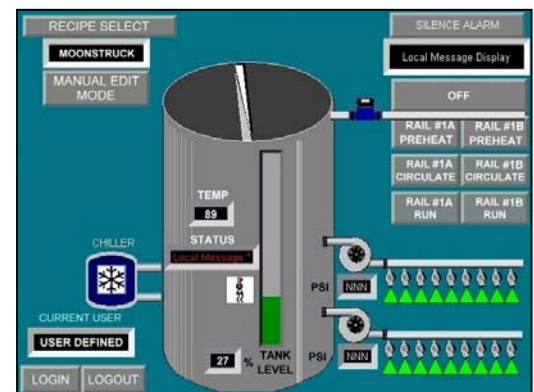

5.2 Creating a New Recipe

1. Initially the unit will be in “AUTO” mode as shown by the following screen. Touch “LOGIN” and enter the authorized user name and password.

NOTE: See your supervisor or contact Burford Corporation for an authorized user name and password.

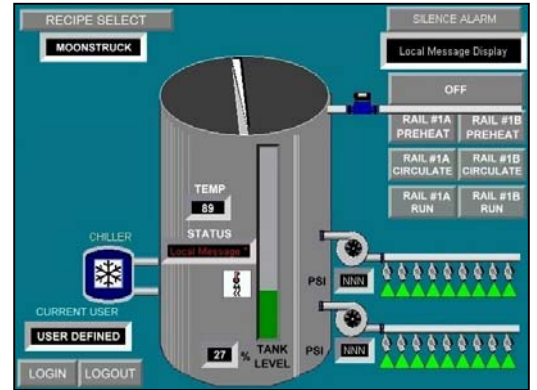

2. Once the login is successful the “MANUAL EDIT MODE” box will be shown in the upper left corner of the screen. To enter the “MANUAL” mode, touch the “MANUAL EDIT MODE” box.

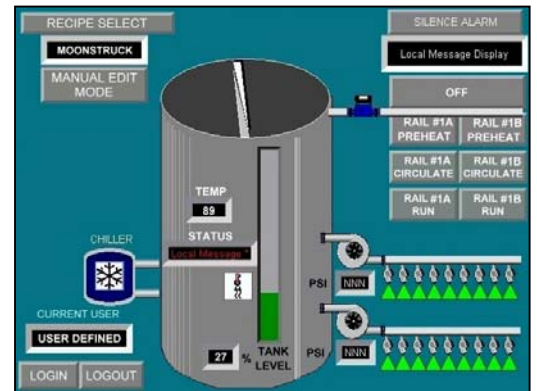

3. Once in the “MANUAL” mode the user now has access to the machine “SETPOINTS” (lower left corner) and “EDIT RECIPE NAME” (upper left corner). See section 5.4 for more information concerning “SETPOINTS”. To change the recipe name touch the “EDIT RECIPE NAME” box and follow screen directions.
4. To exit the “MANUAL” mode touch the “RETURN TO AUTO MODE” box. Then touch the “LOGOUT” box to prevent unauthorized access.

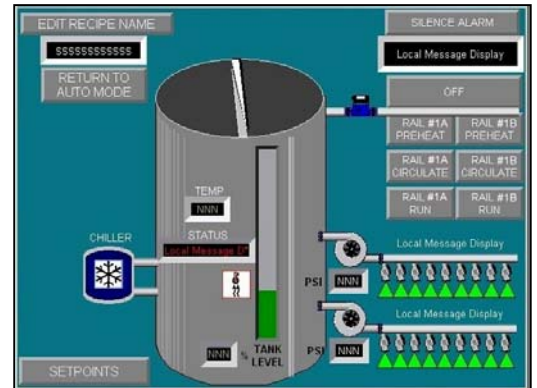

NOTE: All changes made to the machine “SETPOINTS” will be saved to the recipe name shown in the upper left corner of the screen.

5.3 Spray Rail Set-Up

- From the “MAIN MENU” screen, touch a spray rail icon (see arrows).

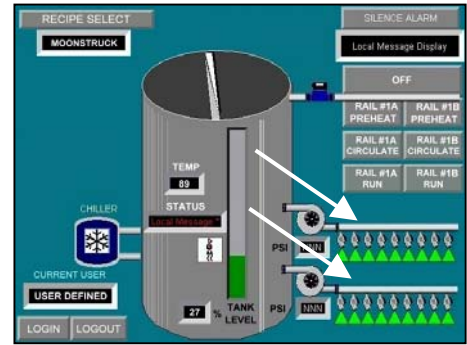

- The following pop-up will be shown. See table below for screen descriptions. To access “SPRAY RAIL #X SPRAY TIMES” touch the desired “SPRAY RAIL #X SPRAY TIMES” box.

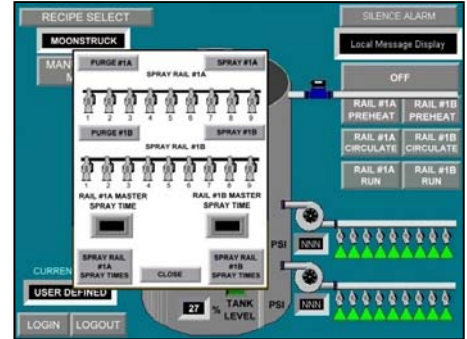

DESCRIPTION	FUNCTION
PURGE #X	All active spray nozzles, for the desired spray rail, dispense product while this button is touched.
SPRAY #X	All active spray nozzles, for the desired spray rail, complete one timed spray cycle.
RAIL #X MASTER SPRAY TIME	Enter amount of time (seconds) that all active spray nozzles will dispense product for (1) spray cycle. Range: -9.999 to +9.999 seconds.
SPRAY RAIL ICON	Individual spray guns may be toggled either “ON” (green) or “OFF” (red) by touching the desired spray gun icon.

- Touch the “SPRAY RAIL #X SPRAY TIMES” box to access the following pop-up screen.

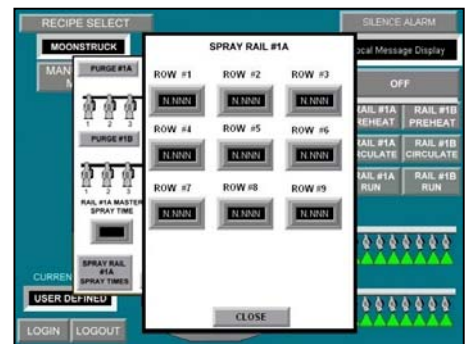

DESCRIPTION	FUNCTION
SPRAY RAIL #X SPRAY TIMES	Allows individual spray time adjustment for each spray valve. This value is the amount of time subtracted or added to the “master spray time” for the respective spray valve. Range: -9.999 to +9.999 seconds.

5.4 Changing Machine Setpoints

There are nine screens related to machine set-up. They are accessible only while in “MANUAL EDIT” mode. From the “MAIN” screen touch “SETPOINTS” and the pop-up screen will be shown. All changes made will **only** be saved to the recipe name shown in the upper left corner. See section 11.2 for table of start up values.

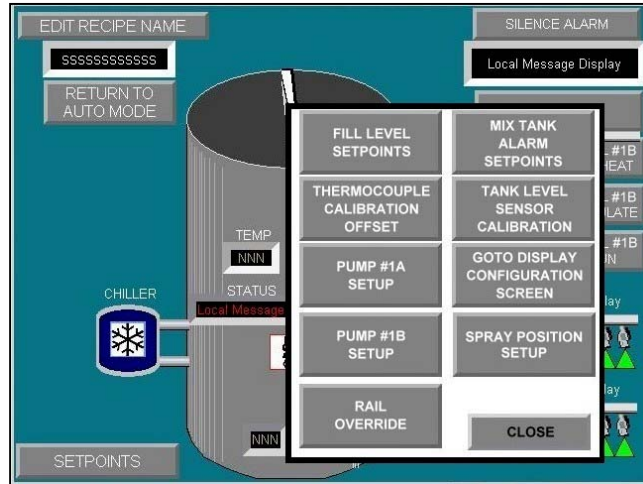

5.4.1 Fill Level Setpoints

1. From the “MAIN MENU” screen, touch “FILL LEVEL SETPOINTS”.
2. The following pop-up screen will appear.
3. This setting determines at what tank level the bulk feed valve will open or close to maintain the product level in the tank. Range: 0 – 100. Once the desired adjustments have been entered touch the “CLOSE” box to return to the previous screen.

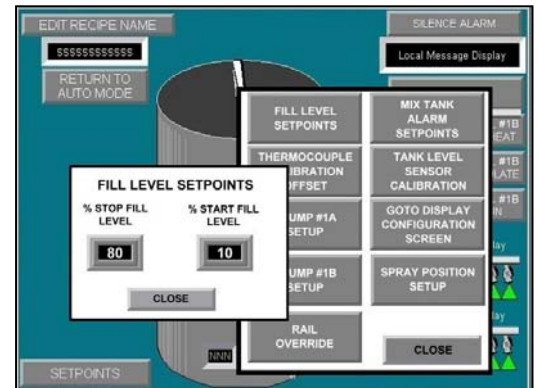

5.4.2 Thermocouple Calibration Offset

1. From the “MAIN MENU” screen, touch “THERMOCOUPLE CALIBRATION OFFSET”.
2. The following pop-up screen will appear.
3. Adjust this offset to correct differences between thermocouple output and actual temperature. Once the desired offset has been entered touch the “CLOSE” box to return to the previous screen. Range: -999 to +999.

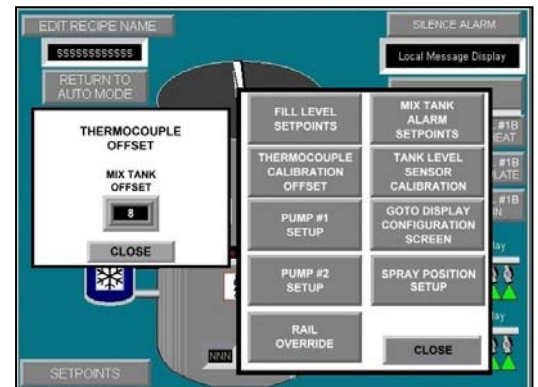

5.4 Changing Machine Setpoints, cont'd.

5.4.3 Pump #1A Setup

1. From the “MAIN MENU” screen, touch “PUMP #1A SETUP”.
2. The following pop-up screen will appear.
3. Once the desired adjustments have been entered touch the “CLOSE” box to return to the previous screen.

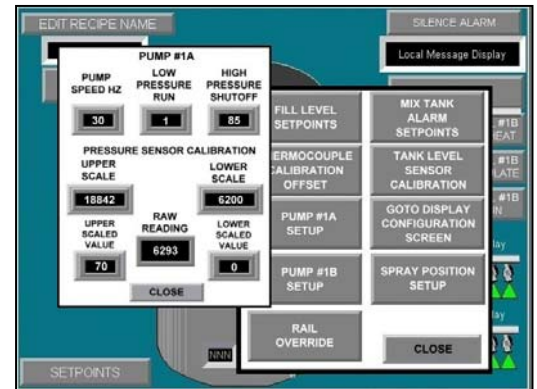

ITEM	DESCRIPTION
Pump Speed HZ	Range: 0 – 75. Determines maximum pump speed.
Low Pressure Run	Range: 0 – 25. Determines pressure (psi) that must be reached while the pump is in “low” speed mode. If the pump does not reach this pressure the unit will shutdown.
High Pressure Shutoff	Range: 0 – 100. Determines pressure (psi) that if reached during “high” speed mode will cause the unit to shutdown.
Upper Scale	Used to calibrate the pressure sensor. Contact Burford Corporation for additional information.
Lower Scale	
Upper Scaled Value	
Raw Reading	
Lower Scaled Value	

5.4.4 Pump #1B Setup

1. From the “MAIN MENU” screen, touch “PUMP #1B SETUP”.
2. The following pop-up screen will appear.
3. Once the desired adjustments have been entered touch the “CLOSE” box to return to the previous screen.

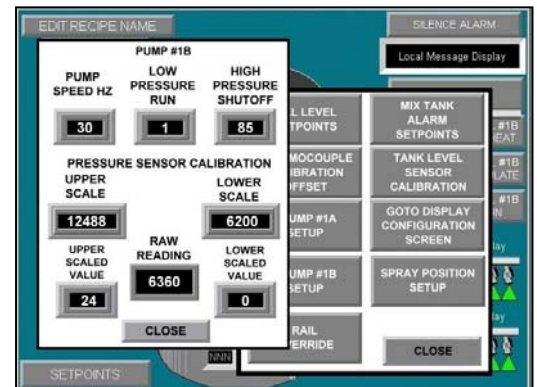

ITEM	DESCRIPTION
Pump Speed HZ	Range: 0 – 75. Determines maximum pump speed.
Low Pressure Run	Range: 0 – 25. Determines pressure (psi) that must be reached while the pump is in “low” speed mode. If the pump does not reach this pressure the unit will shutdown.
High Pressure Shutoff	Range: 0 – 100. Determines pressure (psi) that if reached during “high” speed mode will cause the unit to shutdown.
Upper Scale	Used to calibrate the pressure sensor. Contact Burford Corporation for additional information.
Lower Scale	
Upper Scaled Value	
Raw Reading	
Lower Scaled Value	

5.4 Changing Machine Setpoints, cont'd.

5.4.5 Rail Override

1. From the “MAIN MENU” screen, touch “RAIL OVERRIDE”.
2. The following pop-up screen will appear.
3. When “enabled” the rail number displayed in the box below “set rail” overrides all other spray rails. Useful in the event of rail recognition sensor failure. Once the desired adjustments have been entered touch the “CLOSE” box to return to the previous screen.

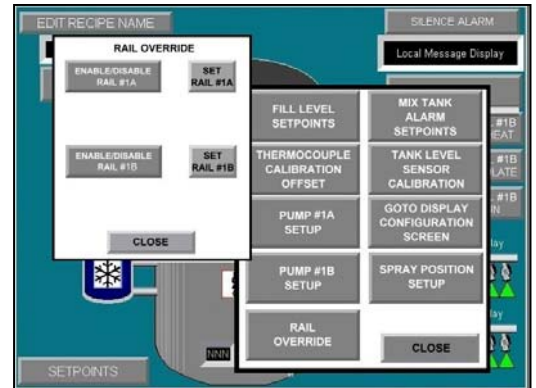

5.4.6 Mix Tank Alarm Setpoints

1. From the “MAIN MENU” screen, touch “MIX TANK ALARM SETPOINTS”.
2. The following pop-up screen will appear.
3. This setting determines at what temperature the alarm will be displayed indicating the maximum (range: 0 – 150) or minimum (range: 0 – 80) desired temperature for the mix tank has been reached. Also sets the tank level (range: 0 – 100) at which the alarm will be displayed to prevent the mix tank from being overfilled. Once the desired adjustments have been entered touch the “CLOSE” box to return to the previous screen.

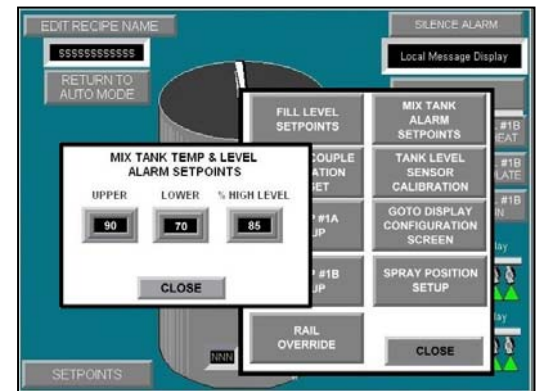

5.4.7 Tank Level Sensor Calibration

1. From the “MAIN MENU” screen, touch “FILL LEVEL SETPOINTS”.
2. The following pop-up screen will appear.
3. This setting is used to fine-tune the sensitivity of the level sensor. Contact Burford Corporation for additional information. Once the desired adjustments have been entered touch the “CLOSE” box to return to the previous screen.

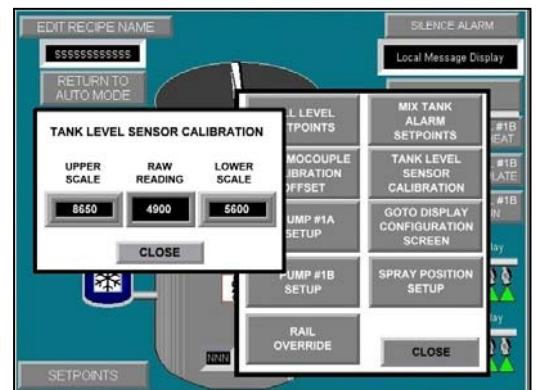

5.4 Changing Machine Setpoints, cont'd.

5.4.8 Goto Display Configuration Screen

These settings are preset at the factory. Contact Burford Corporation for additional information.

5.4.9 Spray Position Setup

1. From the "MAIN MENU" screen, touch "SPRAY POSITION SETUP".
2. The following pop-up screen will appear.
3. This setting is used during initial machine installation. Contact Burford Corporation for additional information. Once the desired adjustments have been entered touch the "CLOSE" box to return to the previous screen. Adjust values and verify machine operation, additional adjustments may be required.

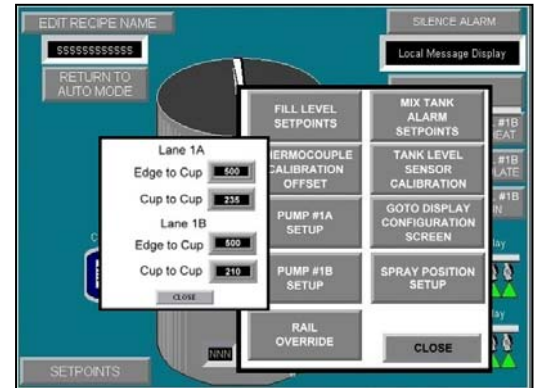

6.0 SETTINGS AND ADJUSTMENTS

6.1 Nozzle Height

The height of your nozzles will determine the amount of product coverage. The higher the nozzle, the greater the coverage, the lowering the nozzles will result in a smaller coverage area and reduced overspray.

To raise or lower the nozzle height, turn the control handle (see figure 6.1).

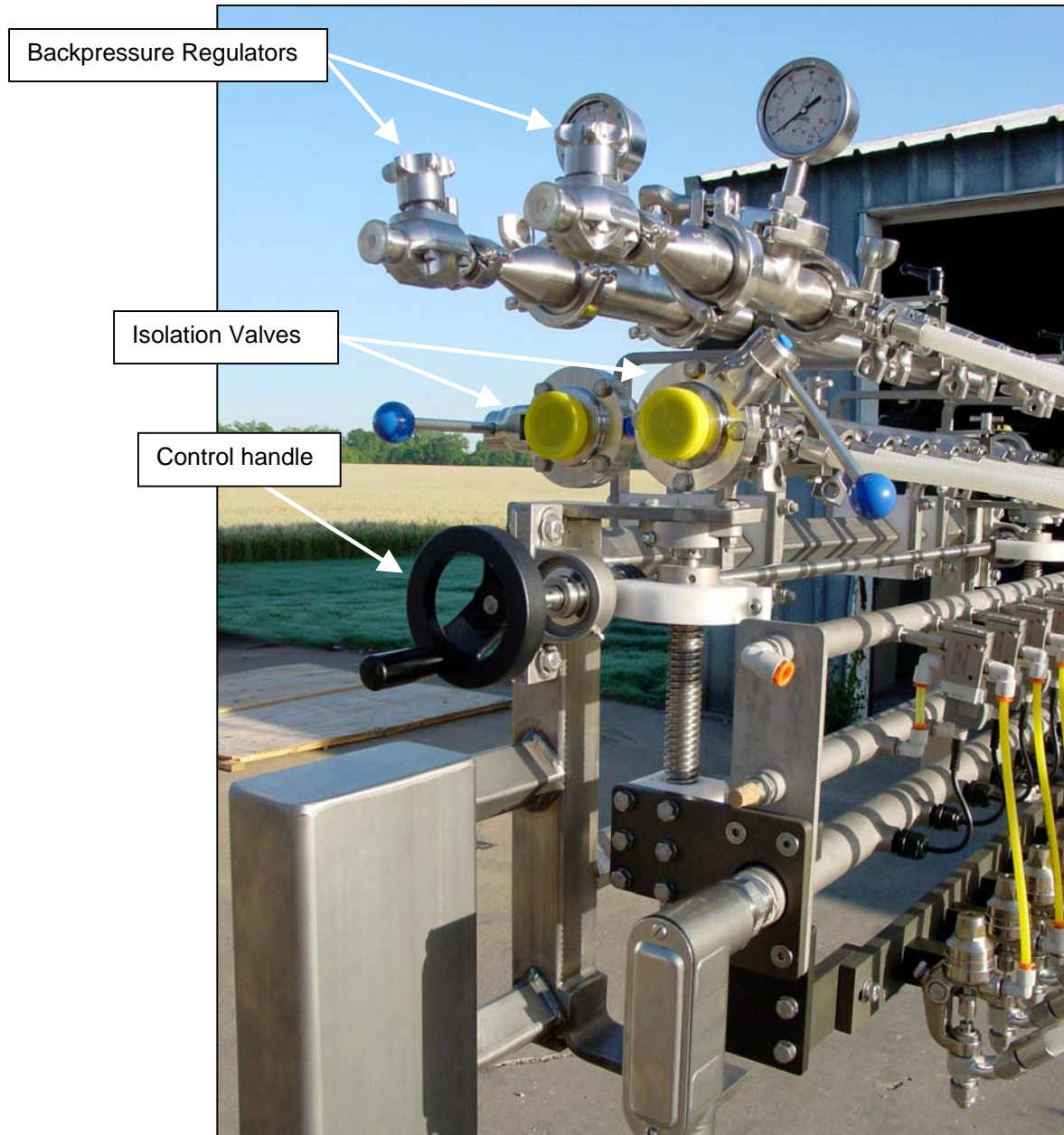

Fig. 6.1

6.2 Actuation and Timing Procedures

6.2.1 Product Sensor

The sensor is to be set to activate the nozzles once the pan has reached the proper position.

The sensor may be adjusted by loosening the mounting bolts and sliding the sensor holder up or down as needed.

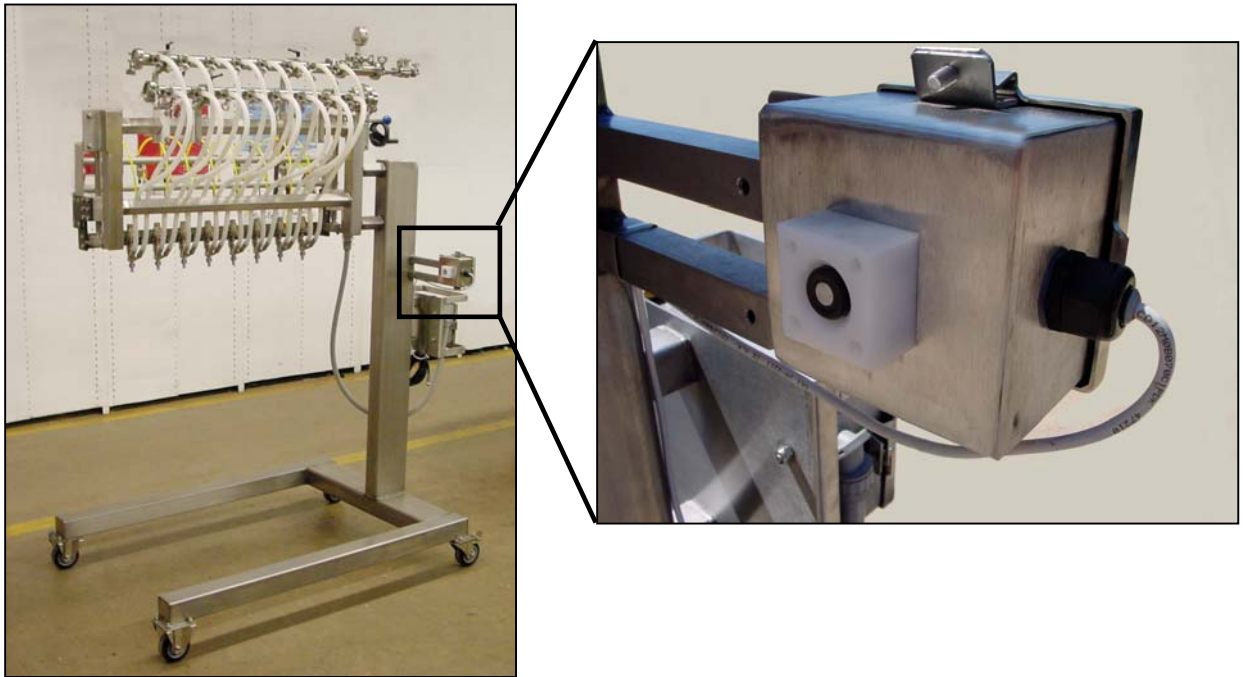
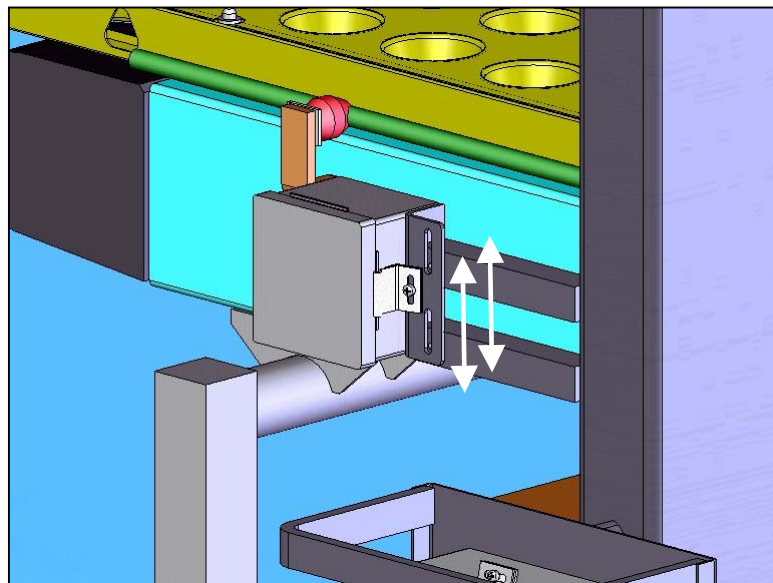

Fig. 4.1



6.3 Product Flow Rate

Four variables influence the dispensing rate; product temperature, actuation time, pump speed and backpressure.

The first variable, product temperature, discussed in section 5.1 affects the viscosity of the product being applied. Note the temperature indicated by the display is the temperature of the circulating water inside the water jacket, NOT the actual product temperature. The actual product temperature changes at a slower rate than the water jacket temperature.

The second variable, actuation time, determines the amount of time in milliseconds the spray valves are actually dispensing product. The dispensing rate may also be changed by changing the spray nozzles, contact Burford Corporation for information concerning different nozzle set-ups.

The third variable, pump speed, controls the rate of flow the pump is capable of discharging. Contact Burford Corporation for information to change this variable.

The remaining variable, backpressure, is indicated by the gauge located at the infeed of the manifold. The valve works by adjusting the knob to limit the flow and increase backpressure. Adjust knob until desired pressure is obtained.

CAUTION: Completely closing the backpressure valve will shut-off the return line, causing an overpressure condition and machine shutdown.

NOTE: See section 6.1 for spray rail component identification.

Spray Rail Identification	Product	Nozzle Part No.	Color Code
1A	GDR	610805-01	Purple
1B	GDR	610805-01	Purple

6.4 Product Tank Level Sensor

The ultrasonic tank level sensor is pre-programmed with the correct operational settings. The sensor's internal settings will work with any of the 8830 units. To maintain interchangeability, these settings should not be modified. This sensor has an analog output and is used to determine fill levels, as well as, alarm setpoint violations.

The agitator is prevented from running when the tank lid is removed.

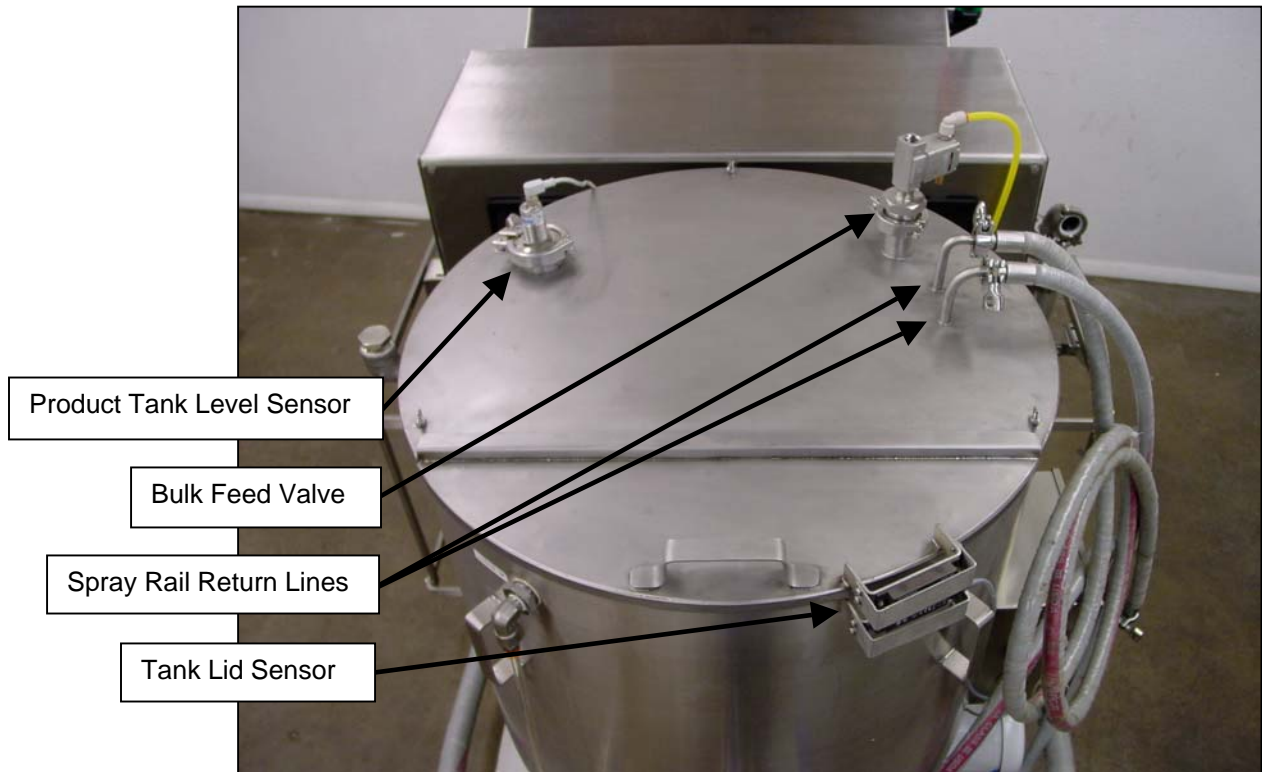

WARNING: Do not depress the small white button on the product tank level sensor. Sensor failure may result.

7.0 PUMP MOTOR DRIVE

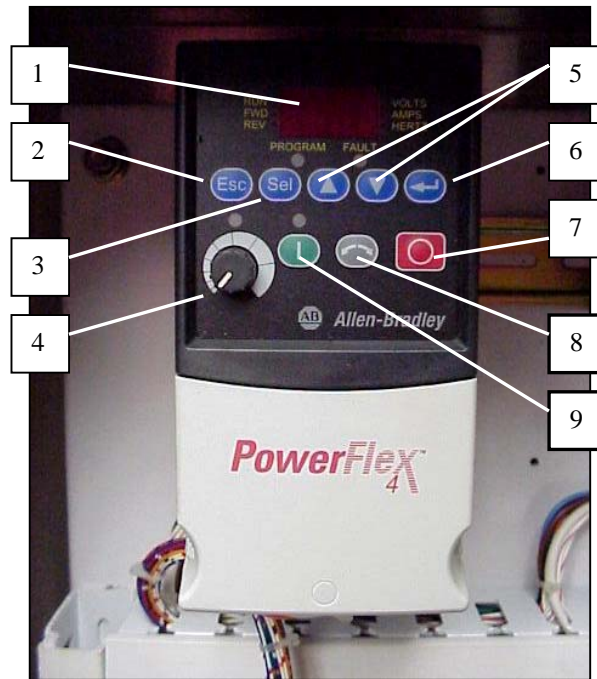

Fig. 6.1

The unit is equipped with an AC motor drive to control the operation of the AC pump motor. The above programmable motor controller is an example of the drive used. The table below provides a brief description of the function keys. See supplied motor drive manual for additional information.

Item	Function	Description
1	Display	Displays parameter groups and values. Also contains status LEDs. See accompanying owner manual for more information.
2	Escape	Back one step in programming menu. Cancels a change and exit programming mode.
3	Select	Advance one step in programming menu. Selects a digit when viewing parameter values.
4	Speed Dial	Used to control speed of drive. This function has been disabled.
5	Scroll	Used to scroll through parameters or to increase/decrease parameter values.
6	Enter	Advance one step in programming menu. Save a change to a parameter value.
7	Stop	Used to stop the drive or clear a fault.
8	Reverse	Used to reverse direction of drive.
9	Start	Used to start the drive.

WARNING: Do Not Use the “Reverse” function, machine damage may result.

7.1 Pump Motor Drive Settings

The motor controllers have been preset at the factory for your particular application. The digital input function is used to configure the controllers for remote operation via the programmable logic controller and touch screen interface. Parameters NOT listed below should be left at the drive manufacturer's default values.

Record set-up values for the following parameters.

Parameter	Machine Setup Value	Description
A052	4	Digital Input 2 Select
A070	0.0 (Hz)	Preset Frequency 0
A071	5.0 (Hz)	Preset Frequency 1
A072	10.0 (Hz)	Preset Frequency 2
A073	20.0 (Hz)	Preset Frequency 3
A081	0.2 (amps)	DC Brake Level
A088	230 (volts)	Maximum voltage
A089	3.5 (amps)	Current Limit
A092	0	Auto Restart Tries
A093	1.0 (seconds)	Auto Restart Delay
P031	230 (volts)	Motor Voltage Rating
P032	60 (Hz)	Motor Frequency Rating
P033	3.5 (amps)	Motor Overload Current
P034	0.0 (Hz)	Minimum Frequency
P035	60.0 (Hz)	Maximum Frequency
P036	5	Start Source
P037	0	Stop Mode
P038	5	Speed Reference
P039	0.1 (seconds)	Accel Time
P040	0.1 (seconds)	Decel Time

8.0 MAINTANENCE AND SERVICE PROCEDURES

8.1 Filling the Product Tank Water Jacket

1. Verify all electrical power is removed from unit.
2. Connect house water supply to yellow water valve located at side of product tank.
3. Turn on house water supply, and then open yellow water valve on product tank.

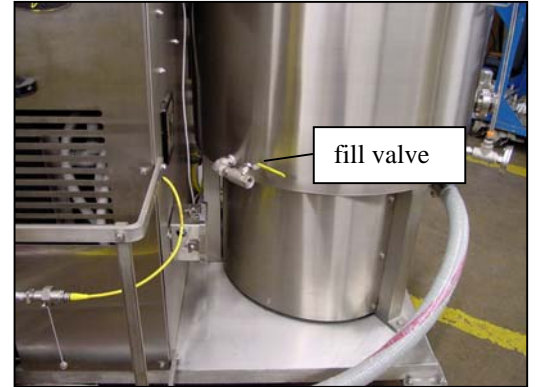

4. Close yellow water valve when water level reaches the sight glass. Turn on the "PREHEAT" from the operator panel. This will operate the circulating pump. Add or remove water until sight tube is half full while the circulating pump is running. **IMPORTANT: If the water jacket is completely filled the water jacket will not vent properly during machine operation.**

NOTE: Visually verify water is circulating through supply and return hoses. Pump damage may occur if ran dry.

5. Turn off house water supply; disconnect supply hose from yellow water valve.

NOTE: Check sight tube daily for correct water level. Additional water may be required due to evaporation.

NOTE: Filling the water jacket too rapidly may result in water expulsion from vent.

8.2 Restoring Product Flow

If the "CIRCULATE" is inadvertently turned off or the unit loses power for an extended period, the product inside the tank may become of too high a viscosity to adequately flow through the system.

1. Turn on unit and select "PREHEAT".
2. Shut isolation valve located on front of product tank.
3. Disconnect inlet hose from valve to pump and manually flush product from line. It may also be necessary to remove and clean the elbow and tee on the infeed side of the pump. Reconnect hose and fittings.
4. Adjust the setpoint to 95° F. Allow product tank to heat to pre-set temperature.
5. Open isolation valve and verify the preheated product has reached the pump infeed.
6. Select "CIRCULATE" from the control panel. Check for fluid circulating through the fluid lines and returning to the product tank.

NOTE: These lines are of quick disconnect design to allow quick change of spray guns. (system **MUST** be depressurized before disconnecting hoses).

7. Allow product temperature to stabilize, test application consistency (purge nozzles), and then resume operation.

NOTE: If the high pressure switch is made, the pump may cycle between low and high speeds, trying to break the viscous fluid up and restore flow.

8.3 Changing the Product Filter

1. Position a suitable catch pan beneath discharge side of the pump and open isolation valve (see section 10.2) to drain product from filter. Once filter has drained, remove product feed hose from filter discharge.
2. Loosen the endbell clamp on the filter assembly, there is a spring inside the assembly so be prepared for the internal components to “spring” out once the clamp is removed.



3. Use care not to damage the o-ring when sliding the filter unit out of the housing.



4. This filter screen is shown without the available filter sleeve. If used, remove and replace filter sleeve with a new sleeve once the filter screen is properly cleaned and checked. To install sleeve: Remove black endcaps from screen and slide sleeve over screen. Once centered, push sleeve inside screen ends on both sides and replace endcaps to secure.



5. Position the spring cap on the end of the filter screen and carefully slide the filter screen into the housing. This may take more than one attempt to allow the spring cap to properly seat on both the filter screen and the spring inside the housing assembly.



6. Position the endbell o-ring into position and compress the spring to allow the endbell clamp to be reassembled.
7. Connect the product hose.
8. Procedure complete.

8.4 Product Pump Seal Maintenance

NOTE: To service seals it is necessary to disassemble the product pump. See Section 10.4 for additional information. This procedure occurs between steps 8 and 9 of Section 10.4.

1. Remove and discard pump body o-rings, using o-ring removal tool furnished with product pump.

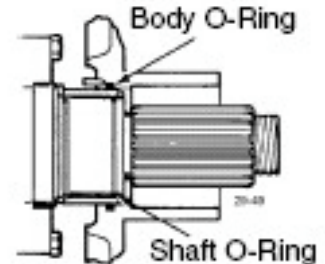

2. Remove shaft sleeves and shaft o-rings.

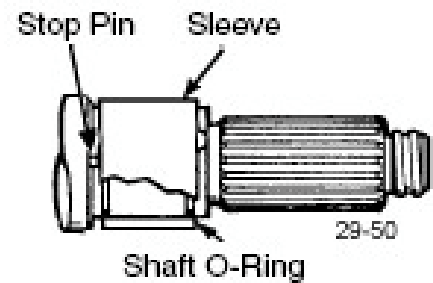

3. Thoroughly clean and inspect o-ring grooves, shafts and sleeves. DO NOT reuse sleeves that are grooved or scratched.

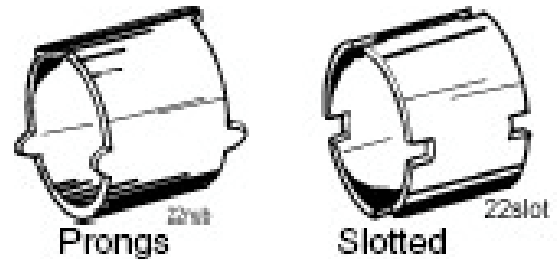

4. Apply an approved o-ring lubricant to NEW o-rings and insert them into pump body grooves and shaft grooves. Shaft o-rings should be installed into the front shaft groove (closest to shaft spline). NOTE: Sleeves may be either slotted or have prongs.

5. Assemble shaft sleeves against shaft shoulder being sure the sleeve prongs DO NOT line up with the drive pin on shaft. However, do place slotted sleeve over pin if you have that type of sleeve.

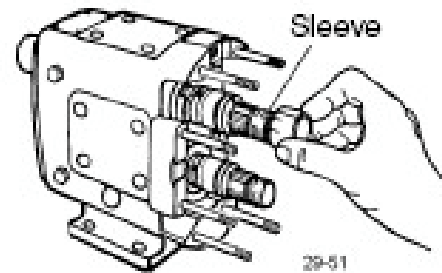

NOTE: See Waukesha Cherry-Burrell publication #95-03002 for complete product pump operation and maintenance procedures.

9.0 START-UP PROCEDURE

1. Turn on Main Disconnect.
2. Allow displays to initialize. Verify the correct recipe is displayed on main menu screen.
3. Drain water separator at incoming air supply (Filter-Regulator-Lubricator assembly).
4. Verify tank water jacket level.
5. Select the "PREHEAT" function and allow the garlic oil to come up to temperature.
6. Check pan sensor(s) location. If necessary, make adjustment.
7. Set nozzle height for spray rail(s) being used.
8. Touch "CIRCULATE" function for the desired spray rail and verify desired product temperature and consistency have been reached.
9. Test spray the application nozzles by pressing the "SPRAY" button on the small enclosure mounted on the spray rail frame.
10. From main menu, switch to "RUN".

9.1 Start-Up Checklist

9.1.1 Mechanical Setup

1. Locate appropriate spray rails into the floor guides from the appropriate side and secure in place with foot lock located under spray box.
2. Locate applicator cart into position and lock wheels to secure.

9.1.2 Electric

1. Connect "Rail A" & "Rail B" cords from cart to spray rail B, matching up labels accordingly. **Caution: Do not force as pin damage may occur.**
2. Connect "Rail A" cord from spray rail B to spray rail A. **Caution: Do not force as pin damage may occur.**
3. Connect power cord from cart to appropriate power drop.
4. Connect pressure switch cable. **Caution: Do not force as pin damage may occur.**
5. Connect level sensor cable. **Caution: Do not force as pin damage may occur.**
6. Connect both ethernet cables from conveyor to applicator cart, located under main electrical enclosure.
7. Turn on main power located on the conveyor.
8. Turn on the local power located on the cart electrical enclosure.

9.1.3 Pneumatic

1. Connect air lines to spray rail A & B. **Caution: Do not turn on air before connecting these lines.**
2. Connect air line to fill valve.
3. Connect main air line from conveyor to filter/regulator located on cart.
4. Turn on main air located on conveyor.
5. Turn on local filter/regulator located on the cart, verify 60 psi on gauge.

9.1.4 Product Lines

1. Connect rail A feed and return hoses from cart to manifolds located on the left side.
2. Connect rail B feed and return hoses from cart to manifolds located on the right side.
3. Connect hoses from bottom/lower front of tank (isolation valves) to the infeed of the pumps, using screen gaskets (black).
4. Connect both hoses between rails A & B.
5. Connect fill hose from tote garlic line to fill valve on top of the tank.
6. Verify fill valve is installed correctly, A=infeed & B=discharge (see picture at right).

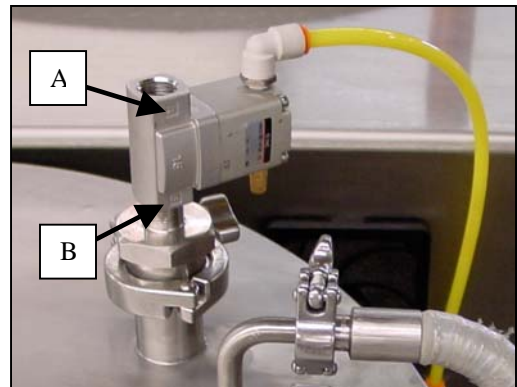

9.1 Start-Up Checklist, cont'd.

9.1.4 Product Lines, cont'd.

7. Verify both filters are installed correctly, bottom = infeed & top = discharge (see picture at right).
8. Verify relief valves are installed correctly, horizontal with side discharge pointing to floor (see picture at right).

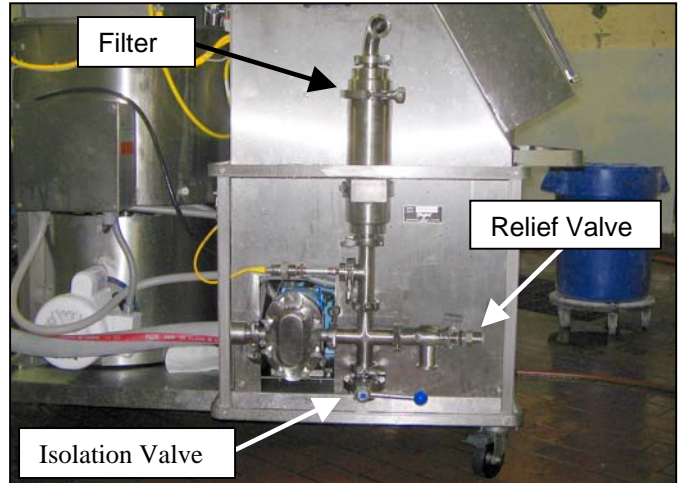

9. Check all tri-clamp connections for tightness and fit.
10. Close both isolation valves coming out of the bottom of the tank, until fluid has reached appropriate level (see picture at right). **Caution: Verify valves are open before turning product pump to circulate.**
11. Close both isolation valves beneath the discharge of both pumps (see picture above). **Note: Valves remain closed during operation, used only to drain and check filter.**
12. Open all isolation valves connected to the spray rails, 6X (see picture below). **Caution: Verify valves are open before turning product pump to circulate.**
13. Open both "free flow valves" located on the spray rails (see picture below). **Caution: Verify valves are open before turning product pump to circulate.**

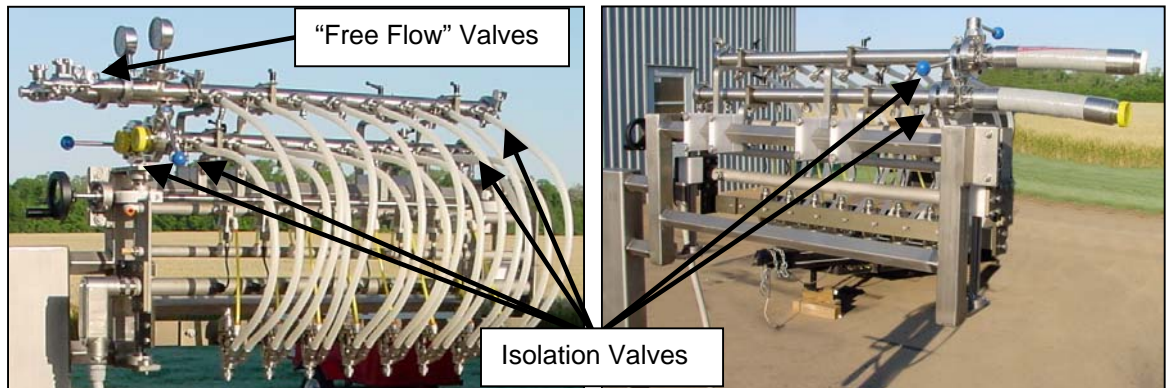

14. Once garlic oil valve has been properly connected, open manual isolation valve on infeed of garlic oil line. **Caution: Verify valve is open before allowing auto-fill to occur.**

9.1.5 Tank Check

1. Verify water level of use tank is in the upper 1/3 of sight tube.
2. Verify lift-off lid is in place.

10.0 CLEANING PROCEDURES

10.1 Basic Procedure (after each production run)

NOTE: Verify “Sanitation” is displayed in the recipe name, see section 5.1 for instructions to change recipe. See section 5.3 for directions to activate and purge all spray nozzles.

1. Disconnect the return line(s) from the top of the product tank and place in a suitable catch container. Pump remaining product into a suitable container.



2. Partially fill product tank with hot water; turn on agitator. Flush through system using “Purge” button as in step 1. Wipe residual product from inside of product tank walls and repeat as necessary until product has been flushed from system.
3. Once the majority of the product has been flushed into a container, reconnect the return line and circulate hot water through system until product has been flushed from supply and return hoses.
4. Purge nozzles.
5. Empty water from system as in step 1.
6. Repeat step 3 and 4 using a hot water solution with a sanitizing agent such as; Ball® mfg Quad10®, then flush with clean water.

NOTE: This procedure will remove most, but not all of, the product inside the product tank and lines. Complete disassembly of the unit, as shown in the following sections, is required to completely clean the system.

CAUTION: Do Not run the product gear pump dry or damage will occur.

10.2 Cleaning the Manifold Assembly

1. Complete steps outlined in “Basic Procedure”.
2. Verify product tank is empty and power sources are secured according to plant lockout/tagout procedures.
3. Position a suitable catch pan beneath the isolation valve (arrow) and open to drain.



4. Disassemble plumbing at all connection fittings to insure effective cleaning of sst piping, pressure hoses and product filter. See section 8.3 for filter disassembly instructions.

NOTE: Use care handling pressure switch.

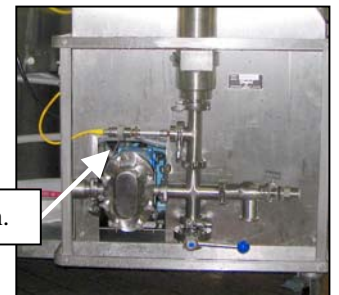

5. Close isolation valve(s) and back pressure valve(s) on manifold(s) to prevent product leakage when moving unit(s) to C.O.P. room for cleaning. Disconnect spray gun product hoses at their respective disconnect fittings.



6. Disassemble manifold fittings as necessary to insure effective cleaning of spray gun hoses and manifold tubing. Manifolds are attached to frame assembly with wingnuts to facilitate removal of the entire manifold for cleaning.



7. Once all components are disassembled, clean interior of all product lines, sanitary fittings and manifolds with a sanitizing solution and/or by pressure washing. C.O.P. tanks are recommended to thoroughly clean pipes, fittings and tubing (where applicable).
8. Assemble (see reference photo, next page) and resume operation.

CAUTION: Do Not submerge spray guns in C.O.P. Tank. Flush with appropriate solution to clean.

Use care when handling the sanitary pressure gauges.

Note orientation of quick connect clamps.

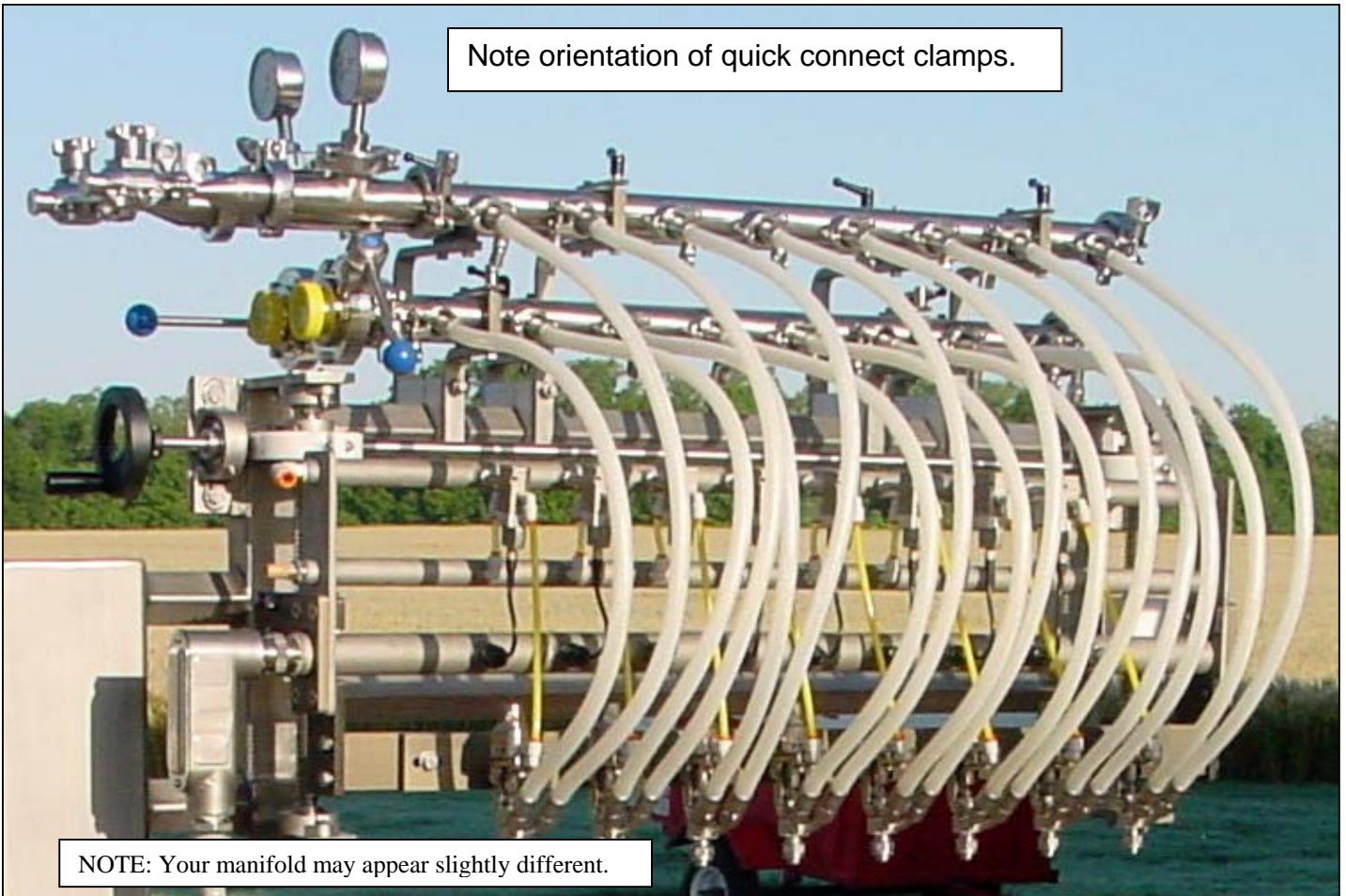

NOTE: Your manifold may appear slightly different.

Reference Photo

10.3 Cleaning the Product Tank and Agitator

1. Loosen and remove wing nuts, then disconnect control cables from the tank level sensor and garlic oil fill valve. Disconnect spray rail return lines.



2. Lift cover from product tank.
3. Loosen set screws securing agitator assembly.
4. Carefully lift agitator from tank. Wipers are spring-loaded use care as they exit product tank.



5. Clean any remaining product from tank and agitator assembly. Rinse with clean water.
6. Assemble in reverse order.

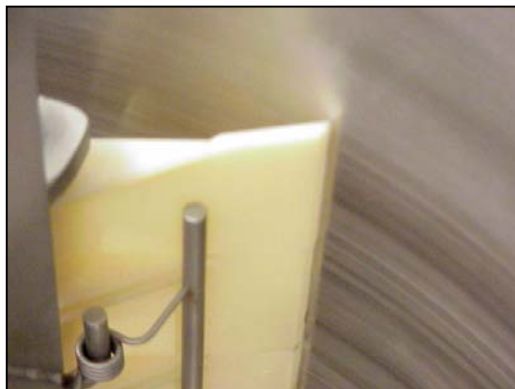

Side wiper orientation



Bottom wiper orientation

10.4 Cleaning the Product Pump

Before beginning this procedure verify product tank and infeed tubing have been drained in accordance with section 10.2.

1. Begin by disconnecting all infeed and discharge tubing from the actual pump assembly. **NOTE: The gasket (P/N 611354) at the infeed of the pump contains a screen for preventing large objects from entering the pump. Very IMPORTANT that this gasket be used here during reassembly.**

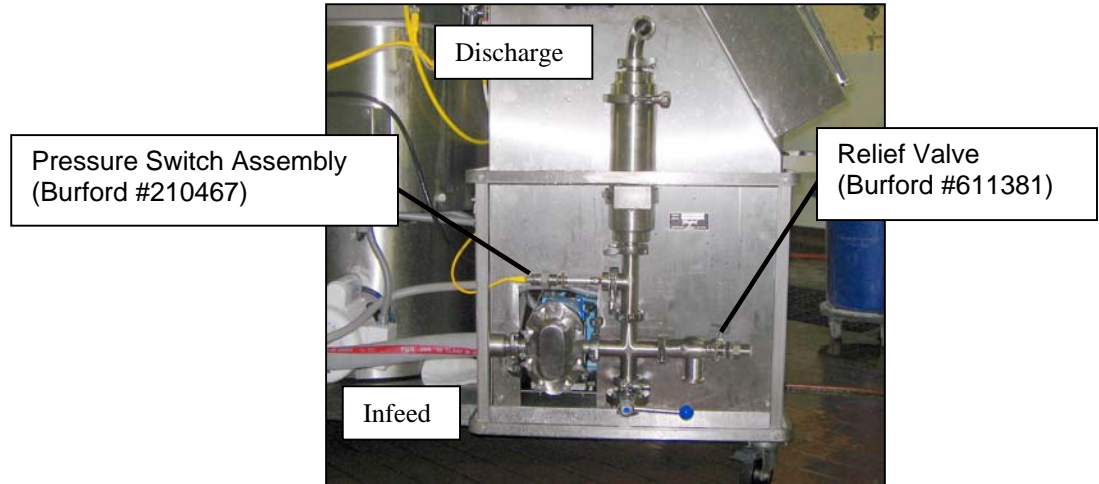

2. Use care when disconnecting the pressure switch.

NOTE: Your pressure switch may differ slightly in appearance.

CAUTION: Do Not Touch the face of the pressure transmitter, this may damage the device.



3. Loosen and remove wing nuts. May require a soft hammer to loosen wing nuts.

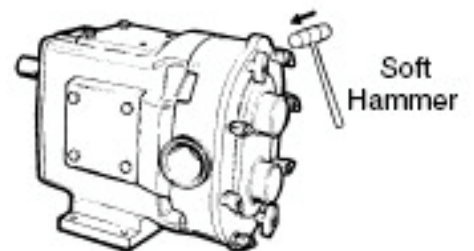

4. Remove cover, if it is stuck, loosen with a soft hammer. Remove and discard cover O-ring.

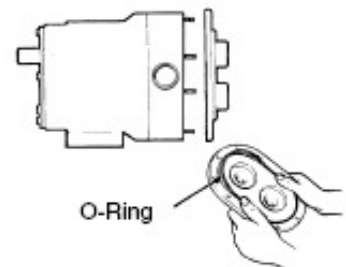

10.4 Cleaning the Product Pump, cont'd.

5. Remove rotor retaining nuts. Use the special wrench supplied with pump and hit it sharply with a soft hammer to loosen nut.

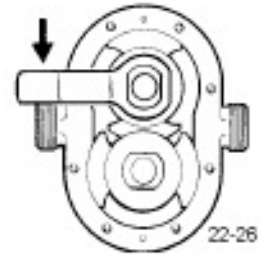

6. Orient rotors perpendicular to each other and remove rotor with both wings exposed first. Handle rotors with care to avoid knicks and scratches. If it is stuck tight, use a gear puller or hardwood lever behind rotor hub to force it off the spline.

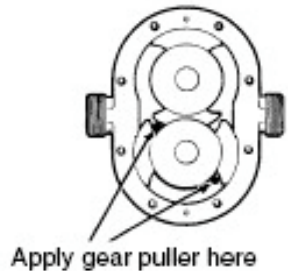

7. Remove pump body by pulling it straight off studs. Use a soft hammer to assist if body is stuck tight.

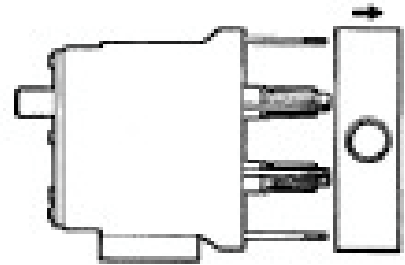

8. Clean and inspect pump body and rotors thoroughly.

9. Once components are clean, begin re-assembly by sliding the pump body over drive shafts and mounting studs. NOTE: Be careful seal components are not knicked or knocked out of place. Press body firmly against gear case engaging dowels.

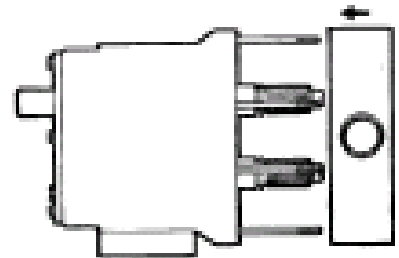

10. Assemble a rotor onto shaft engaging the large spline tooth with the large groove in rotor. Rotate shaft until rotor wings are on vertical centerline. Install second rotor and secure both rotor retaining nuts (clockwise). Tighten the nuts to 30 foot-pounds.

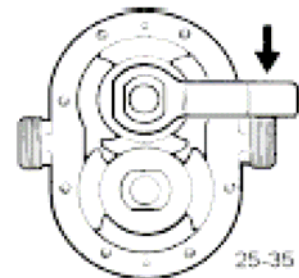

10.4 Cleaning the Product Pump, cont'd.

11. Install O-ring in cover groove.

12. Mount cover on studs and push it against pump body being sure the O-ring remains in the groove.

13. Attach wing nuts (clockwise) and tighten by hitting them sharply with a soft hammer.

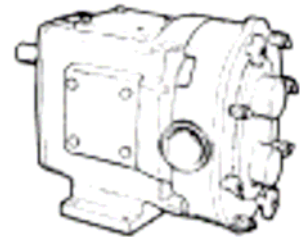

NOTE: Lightly coat all O-rings with a food grade lubricant (grease) upon reassembly.

NOTE: See Waukesha Cherry-Burrell publication #95-03002 for complete operation and maintenance procedures.

11.0 TROUBLE SHOOTING

Problem: Spray nozzles starting too early.
Possible Solution: Proximity sensor to nozzle timing (See section 5.4.9).

Problem: Proximity sensor not sensing pans
Possible Solution: Faulty proximity sensor.

Problem: Nozzle(s) not dispensing
Possible Solution: Blockage in nozzle(s).
Check back pressure valve setting.
Spray nozzle(s) not enabled (See section 5.3).

Problem: Too much or too little garlic oil per pan
Possible Solution: Check back pressure valve setting (See section 6.4).

11.1 Light Tower Descriptions

FUNCTION	DESCRIPTION
Solid Green Light	Indicates normal machine operation.
Solid Blue Light	Indicates the unit is in "BATCH" mode (if equipped).
Blinking Blue Light	Indicates the unit is in "BATCH" mode (if equipped) and is waiting for user input.
Blinking Yellow (Amber) Light	Indicates there is a spray rail mismatch.
Solid Yellow (Amber) Light	Indicates the "RAIL OVERRIDE" function is currently being used. See Section 5.4.5.
Solid Red Light	Indicates there is a machine fault. See control panel for possible fault description.

11.2 Set-Up Values

Station #1 Product: FTO GDR Ingredient: Garlic Soy Oil RMATL: 224302			
Fill Level Setpoints		Mix Tank Temp & Alarm Setpoints	
% Stop Fill	80	Upper Temp	90
% Start Fill	10	Lower Temp	70
		% High Level	85
		Mix Tank Temp Setpoint	85
Rail Override		Thermocouple Offset	
1A set	0	Mix Tank	8
1B set	1		
Pump 1A Set-Up		Pump 1B Set-Up	
Pump Speed	30	Pump Speed	30
Low Pressure Run	1	Low Pressure Run	1
High Pressure Shutoff	85	High Pressure Shutoff	85
Pressure Sensor Calibration		Pressure Sensor Calibration	
Upper Scale	18842	Upper Scale	12488
Lower Scale	6200	Lower Scale	6200
Raw	6293	Raw	6360
Upper Scaled Value	70	Upper Scaled Value	24
Lower Scaled Value	0	Lower Scaled Value	0
Tank Level Calibration		Spray Position Set-Up	
Upper	8650	1A Edge to Cup	500
Raw (when empty)	4900	1A Cup to Cup	235
Lower	5600	1B Edge to Cup	500
% (when empty)	-22	1B Cup to Cup	210
Spray Rail Set-Up			
Master Spray Time 1A	0.015	Master Spray Time 1B	0.015
1A Spray Offset		1B Spray Offset	
Lane 1	0	Lane 1	0
Lane 2	0.002	Lane 2	0
Lane 3	0	Lane 3	0
Lane 4	0	Lane 4	0
Lane 5	0	Lane 5	0
Lane 6	0	Lane 6	0
Lane 7	0	Lane 7	0
Lane 8	0	Lane 8	0
Rail 1A Backpressure	16	Rail 1B Backpressure	16
Rail 1A Height	TBD	Rail 1B Height	TBD

12.0 RECOMMENDED SPARE PARTS

QTY.	PART NUMBER	DESCRIPTION
1	210451	ASSEMBLY, ENCODER w/CABLE
1	611204	CHILLER, ½ HP, CUSTOM
1	611222	CONTROLLER, PWR-FLEX4, 220-1 INPUT, 220-3 OUTPUT, 1 HP
1	610899	COUPLING, HELICAL, PUMP DRIVE SYSTEM
1	611282	FILTER, #1, MIST COLLECTOR, STD – Yellow
1	611283	FILTER, #2, MIST COLLECTOR, Secondary – Pink
1	611284	FILTER, #3, MIST COLLECTOR, Containment – White
10	611031	FILTER, MEDIA, 40 MICRON, CLOTH
5	611354	GASKET, SST SCREEN, 1 1/2 TRI-CLAMP
15	610803	GASKET, TEFLON, ½”
15	610760	GASKET, TEFLON, 1-1/2”
1	611188	GEARBOX, WASHDOWN, NIAGARA, PUMP DRIVE SYSTEM
1	611216	GEARBOX, AGITATOR 300/450/750 LB TANK
2	611215	HEATER, 1000 WATT, 300/450/750 LB TANK
1	610778	HEATER, FIREROD CARTRIDGE, SST, MELTING RACK
5	611209	HOSE, ½” TRI-CLAMP X 9/16-18 JIC
1	611239	HOSE, SANITARY, RETURN, 1/2” X 10’. OAL
1	610754	HOSE, SANITARY, TRANSFER, 1-1/2” X 10’, OAL
1	611243	HOSE, SANITARY, TRANSFER, 1-1/2” X 14”, OAL
1	611208	HOSE, SANITARY, TRANSFER, 1-1/2” X 2’, OAL
1	611207	HOSE, SANITARY, TRANSFER, 1-1/2” X 4’, OAL
1	611234	HOSE, SANITARY, TRANSFER, 1-1/2” X 5’, OAL
1	611221	MIXER, HIGH SPEED
1	610748	MOTOR, 1 HP, 230/460-3, 56C, WASHDOWN, NO BASE, PUMP DRIVE SYSTEM
1	611220	MOTOR, AGITATOR 300/450/750 LB TANK
1	611212	O-RING, VALVE SEAT, DOUBLE DIAPHRAGM PUMP
1	304160	POWER SUPPLY, 110/220 TO 24 VDC, 10 AMP
1	611198	PUMP, HOT WATER CIRCULATOR, 1/12 HP
1	611206	PUMP, SANITARY DOUBLE DIAPHRAGM
1	611197	PUMP, SANITARY, WAUKESHA -015
1	C01029	RELAY, 24 VDC, 2PDT, 8 PIN (K10)
1	A08361	RELAY, 24 VDC, 3PDT, 11 PIN OCTAL
1	A02403	RELAY, 24 VDC, 4PDT, 14 PIN KHA
1	610404-001	RELAY, TERMINAL MOUNTING, 24 VDC, 1PDT, 6 AMP
1	611210	REPAIR KIT, AIR, DOUBLE DIAPHRAGM PUMP
1	611211	REPAIR KIT, ELASTOMER, DOUBLE DIAPHRAGM PUMP
2	C00527	REPAIR KIT, SPRAY GUN
1	611357	SENSOR, FLOW METER, STATION 3
1	C06752-001	SENSOR, PROX, 80MM, 10-55 VDC, PNP, EDDY
1	611259	SENSOR, PROXIMITY, 18 MM, M12
2	611202	SENSOR, ULTRA-SONIC, DUAL-LEVEL, ANALOG
5	611251	SPRAY GUN, RECIRCULATING INLET, SPECIAL
1	210467	SWITCH, PRESSURE TRANSDUCER, SANITARY, 1-1/2” TRI-CLAMP
1	611217	THERMOCOUPLE, TYPE K, 6” LONG, SS
1	610779	THERMOCOUPLE, TYPE K, MELTING RACK
5	611287	TIP, NOZZLE, FULL CONE, STATION #3
5	C00536	TIP, NOZZLE, TEE-JET, STRAIGHT STREAM, STATION #1
5	611279	TIP, NOZZLE, UNIJET, FLAT SPRAY, STATION 2B
5	610805-04	TIP, NOZZLE, VISIFLO GREEN, 0.15 GPM, CONE, STATION 2A
5	610805-01	TIP, NOZZLE, VISIFLO PURPLE, 0.050 GPM, STATION 2C
1	611358	TRANSMITTER, FLOW METER, STATION 3
5	611230	VALVE, 3 PORT, 1/8 NPT, M8
1	611205	VALVE, PNEUMATIC, 3-WAY, BALL
1	611218	VALVE, SOLENOID, ½” FLUID, AIR OPERATED, SST
6	611378	O-RING, COVER, WAUKESHA -015, FKM
8	611379	O-RING, PUMP BODY, WAUKESHA -015, FKM
8	611380	O-RING, SHAFT, WAUKESHA -015, FKM

13.0 PREVENTIVE MAINTENANCE

In order to ensure proper performance of your unit, the following should be done as noted.

1. Flush tank and spray nozzles after each production run with hot water.
2. Remove and clean nozzle tips weekly.
3. Visually inspect air and product lines. Replace when needed.
4. Break apart and clean product pump as needed.
5. Visually inspect vacuum assembly filters. Replace when needed.
6. Check sight tubes daily for correct water level.

14.0 PARTS LISTS / ASSEMBLY DRAWINGS

14.1 Waukesha Pump Part Identification

ITEM NO.	PART NO.	QTY	DESCRIPTION
1	See note	1	BODY, PUMP, 015-U1
2	See note	1	COVER, PUMP
3	See note	1	CASE, GEAR, CAST IRON
4	See note	1	COVER, GEAR CASE
5	See note	1	GEAR, DRIVE SHAFT, SPUR
6	See note	1	GEAR, SHORT SHAFT, SPUR
7	See note	1	SHAFT, DRIVE
8	See note	1	SHAFT, SHORT
9	See note	2	ROTOR, TWIN WING, ALLOY 88
10	See note	8	STUD, PUMP MOUNTING
11	See note	8	NUT, WING
12	See note	1	OIL SEAL, GEAR CASE COVER
13	See note	2	OIL SEAL, GEAR CASE REAR
14	See note	2	GREASE SEAL, BEARING RETAINER
15	See note	2	BEARING, REAR
16	See note	2	BEARING, FRONT
17	See note	2	KEY, GEAR
19	See note	2	DRIVE PIN, SEAL SEAT AND SLEEVE
20	See note	1	DOWEL PIN, UPPER, COVER SIDE
21	See note	1	DOWEL PIN, UPPER, GEAR CASE SIDE
22	See note	1	DOWEL PIN, LOWER, COVER SIDE
23	See note	1	DOWEL PIN, LOWER, GEAR CASE SIDE
24	See note	6	PLUG, DRAIN & FILL LEVEL
25	See note	1	SILICONE SEALANT
26	See note	4	JAM NUT, ROTOR
27	See note	2	SHIM, FRONT BEARING
29	See note	2	SPACER, GEAR TO REAR BEARING
30	See note	2	SPACER, BEARING
32	See note	2	BEARING RETAINER, FRONT
33A,33B	See note	14	SCREW, 1/4-20 X 3/4"
33C	See note	6	WASHER, 1/4" FLAT, GEAR CASE COVER
34	See note	1	DOWEL BUSHING, UPPER
35	See note	1	DOWEL BUSHING, LOWER
36	611378	1	O-RING, PUMP COVER, FKM
37	See note	2	STOP PIN, SEAL
39	See note	2	WASHER, LOCK, GEAR
41	See note	2	LOCKNUT, GEAR
42	See note	1	SHIM, GEAR CASE

NOTE: Contact Waukesha Cherry-Burrell (800-252-5200) with serial number of pump for part numbers.

14.1 Waukesha Pump Part Identification, cont'd.

ITEM NO.	PART NO.	QTY	DESCRIPTION
43	See note	8	PLASTIC CAP PLUG
44	See note	4	SCREW, 5/16-18 X 1"
47	See note	1	KEY, COUPLING
48	See note	2	PLUG, CLEANOUT
61	See note	1	NAMEPLATE, SANITARY
62	See note	4	SCREW, #2 X 1/8"
63	See note	1	TOOL, O-RING REMOVAL
64	See note	1	WRENCH, ROTOR NUT REMOVAL
65	See note	2	PLATE, CAUTION
66	See note	2	LABEL, WARNING
67	See note	4	FITTING, GREASE, 1/8"
68	See note	4	PLASTIC CAP, GREASE FITTING

NOTE: Contact Waukesha Cherry-Burrell (800-252-5200) with serial number of pump for part numbers.

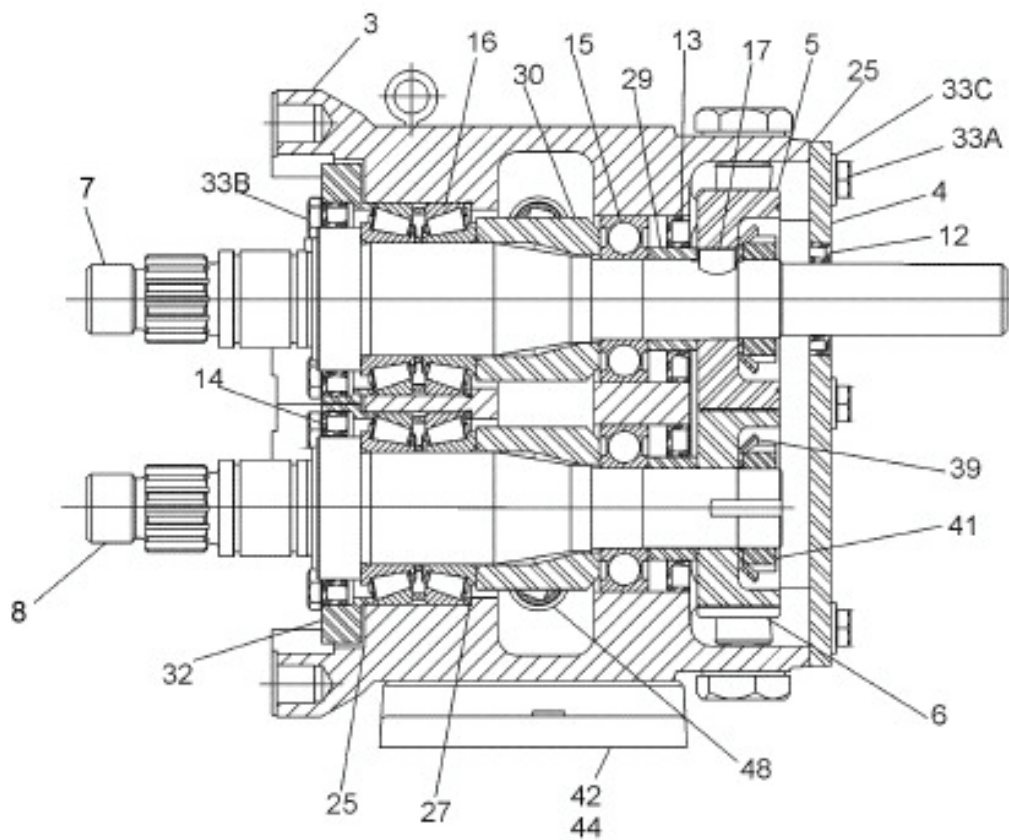
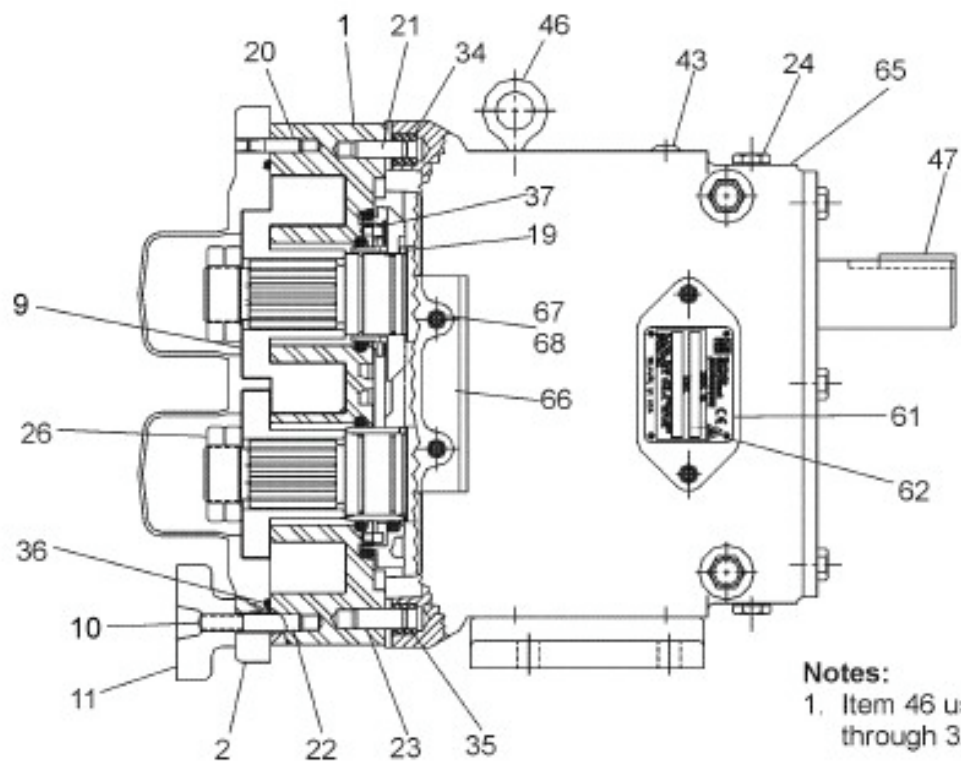

14.2 Waukesha Pump Seal Identification

ITEM NO.	PART NO.	QTY	DESCRIPTION
81	611379	2	O-RING, PUMP BODY, FKM
82	611380	2	O-RING, SHAFT, FKM
83	See note	2	SLEEVE, SHAFT

NOTE: Contact Waukesha Cherry-Burrell (800-252-5200) with serial number of pump for part numbers.

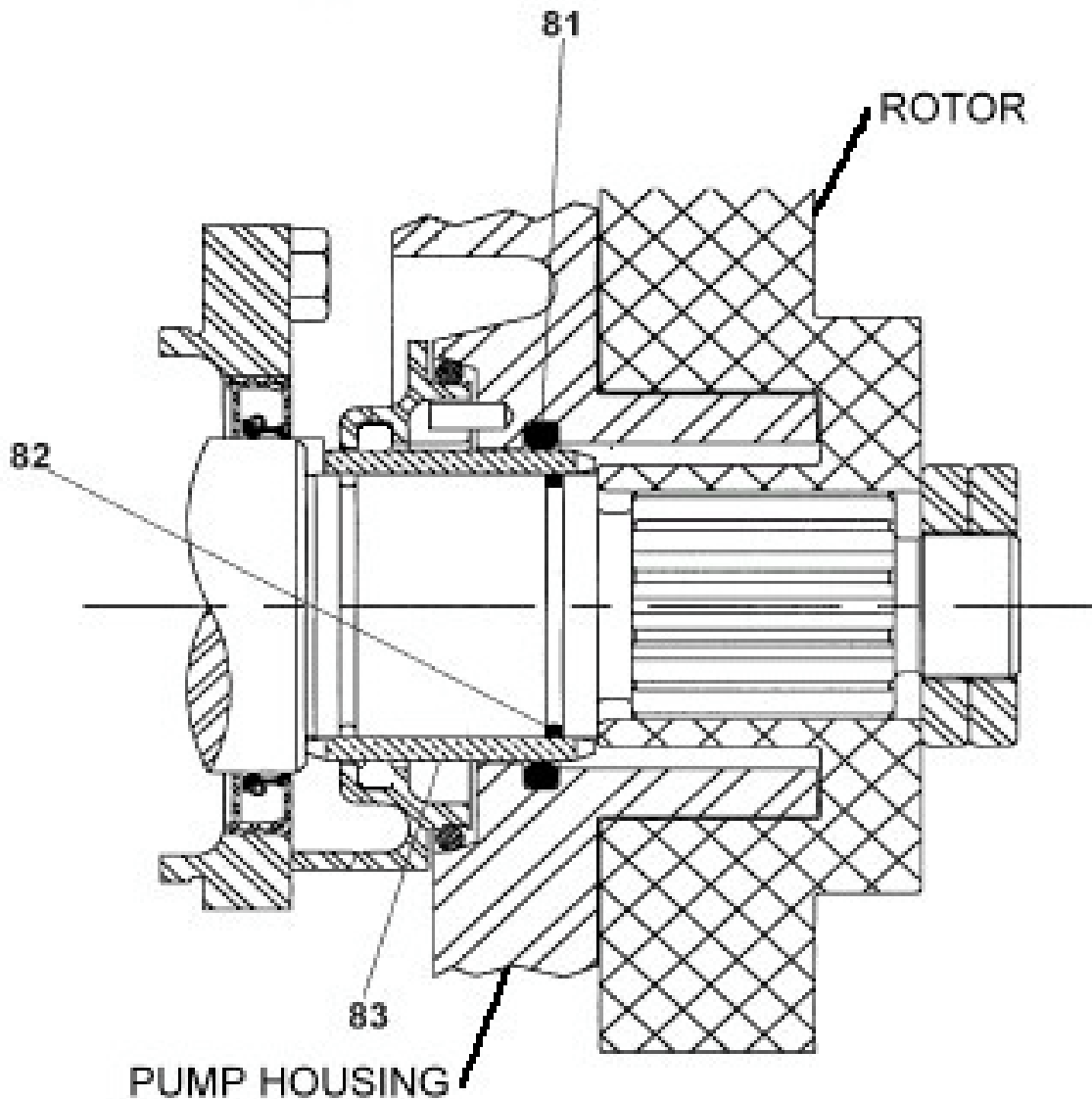

14.3 Pump System

ITEM NO.	PART NO.	QTY	DESCRIPTION
1	610748	1	MOTOR, 1 HP, 230/460, 3 PHASE, 56C, W-D, RG-BS
2	611188	1	GEARBOX, WASHDOWN, NIAGARA
3	610899	1	COUPLING, HELICAL
4	611197	1	PUMP, SANITARY, WAUKESHA -015

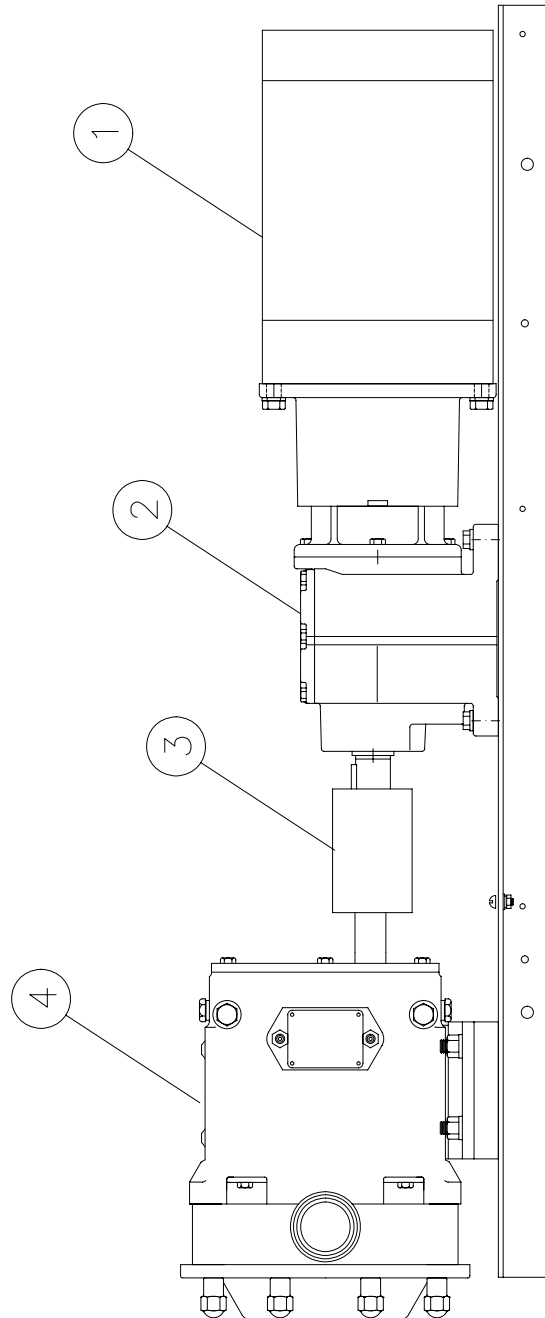

14.4 Tank Detail

ITEM NO.	PART NO.	QTY	DESCRIPTION
1	611220	1	MOTOR, AGITATOR, 300/450/750 LB
2	611216	1	GEARBOX, AGITATOR, 300/450/750 LB
3	47877-238	1	TORQUE LIMITER, BOTTOM DRIVE

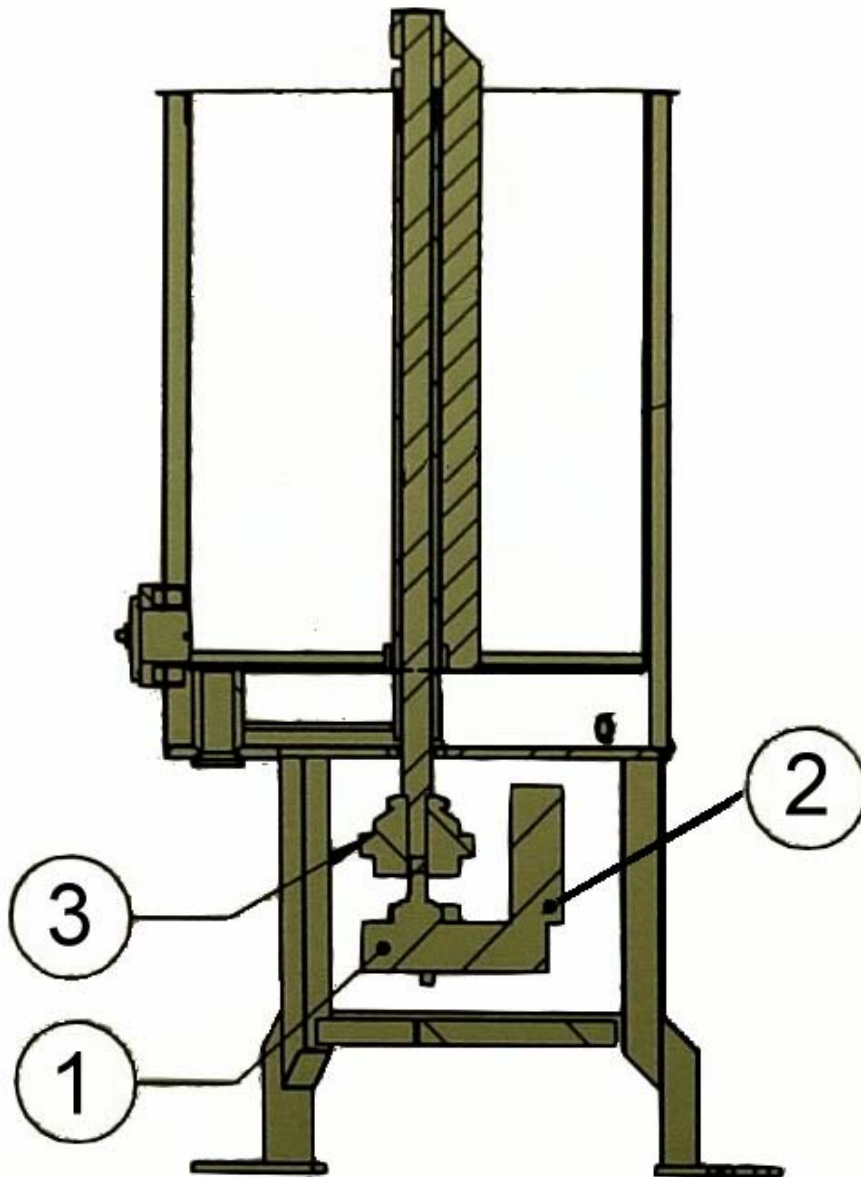

SECTION A-A

14.5 Agitator Assembly

ITEM NO.	PART NO.	QTY	DESCRIPTION
1	47877-226	1	ASSEMBLY, AGITATOR ROD & SPRING, 200#
2	47877-225	1	SCRAPER, AGITATOR, BOTTOM RIGHT
3	47877-224	1	SCRAPER, AGITATOR, BOTTOM LEFT

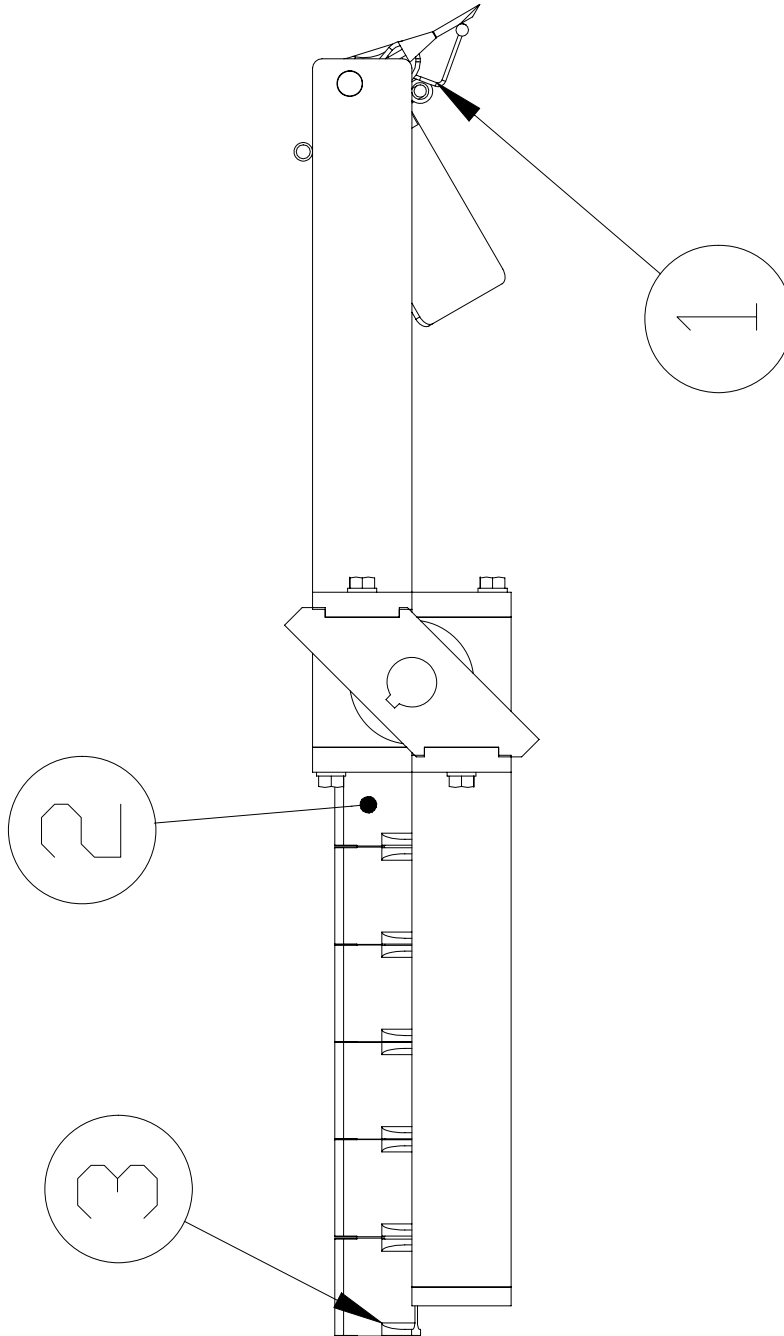

14.6 Miscellaneous Part Identification

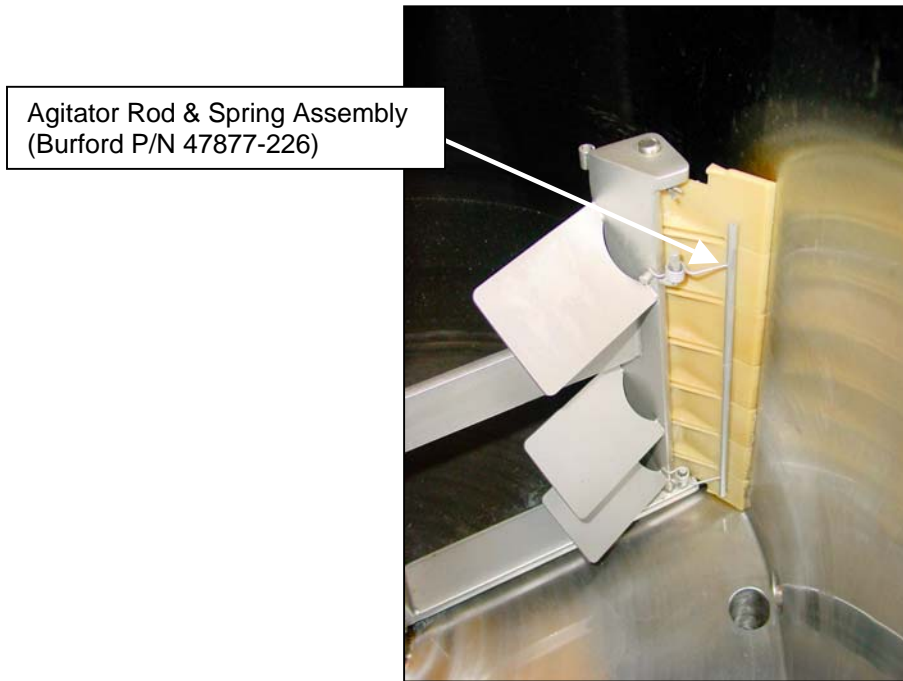
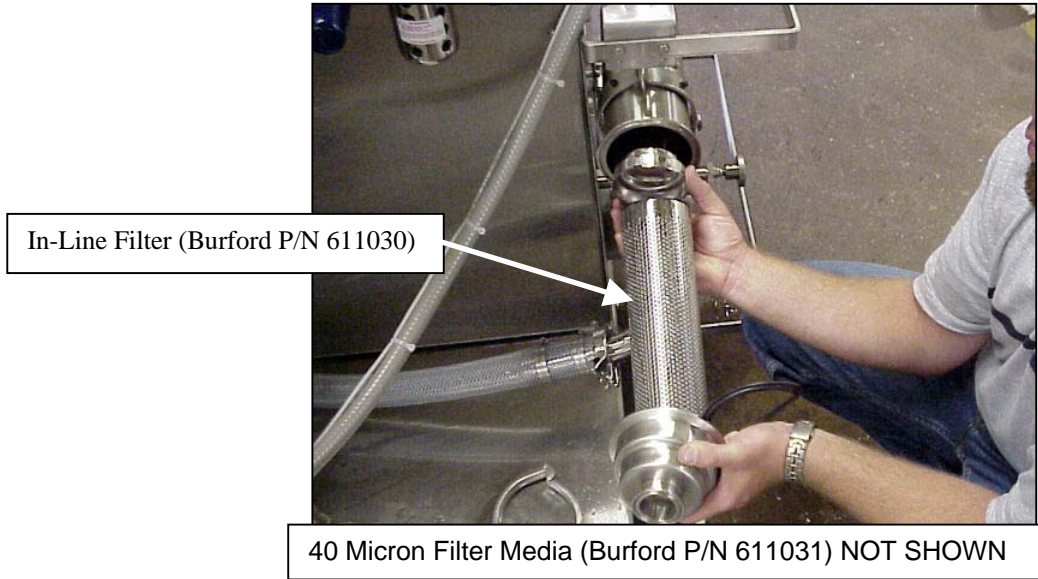

14.6 Miscellaneous Part Identification, cont'd.

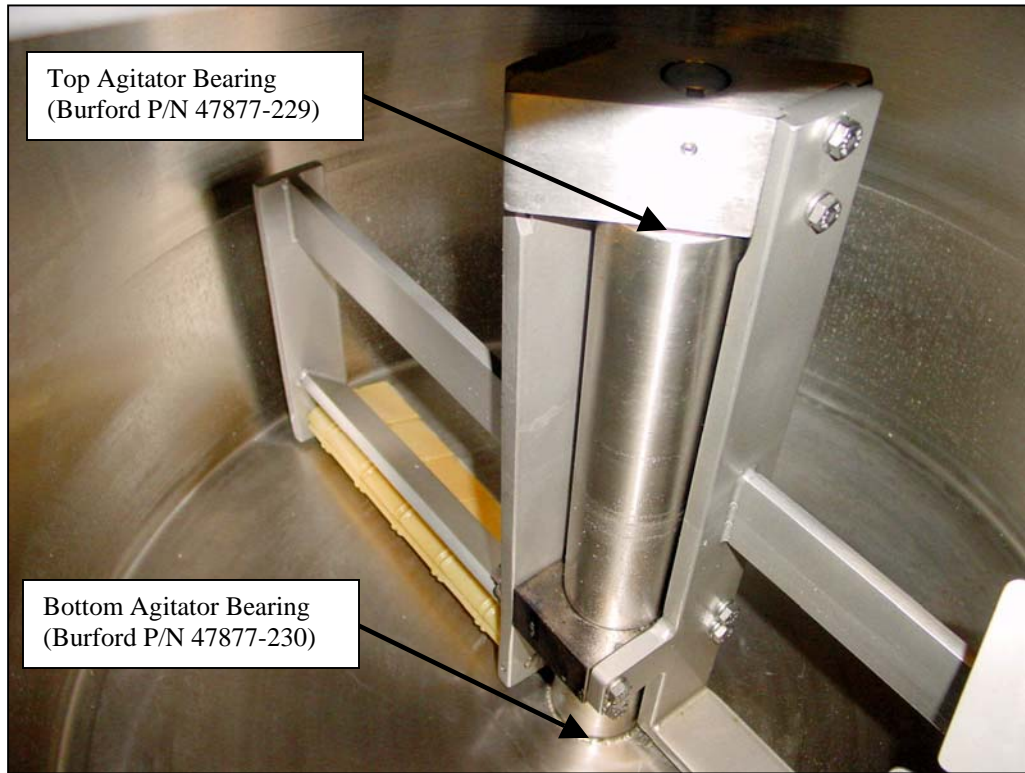

14.7 Standard Wiring Diagram

REF	SYMBOL	PART #	QTY	DESCRIPTION
1	CB1	C07650-030	2	CIRCUIT BREAKER, 30 AMP
2	CB2,5,6	C07650-010	6	CIRCUIT BREAKER, 10 AMP
3	CB3,4	C07650-005	4	CIRCUIT BREAKER, 5 AMP
4	CB6	C07650-002	2	CIRCUIT BREAKER, 2 AMP
5	CB7	C07650-015	2	CIRCUIT BREAKER, 15 AMP
6	CB1-7	C07648	8	ROD, CIRCUIT BREAKER CONNECTING
7	CBL1,2	611149	2	CABLE, SENSOR, 1-16 UNC, 19 WIRE, FEMALE
8	CBL1,2 P/O	611148	2	CONNECTOR, BULKHEAD, 19 WIRE, MALE
9	CBL1,2 P/O	611174	2	CONNECTOR, ADAPTER, PG16 TO ½" NPT
10	CRM	C07245	1	CONTACTOR, 10 AMP, 24 VDC, 4 POLE
11	CR1,2	610404-001	2	RELAY, TERMINAL MOUNTING, 6 AMP, 1PDT
12	CR3,6	C01029	2	RELAY, 24 VDC, 2PDT, 8 PIN OCTAL
13	CR3,6 P/O	C06723	2	BASE, RELAY, DIN MOUNTING, 8 PIN OCTAL
14	CR4	A08361	1	RELAY, 24 VDC, 3PDT, 11 PIN OCTAL
15	CR4 P/O	C06724	1	BASE, RELAY, DIN MOUNTING, 11 PIN OCTAL
16	CR5	A02403	1	RELAY, 24 VDC, 4PDT, 14 PIN KHA
17	CR5 P/O	A02499	1	BASE, RELAY, DIN MOUNTING, 14 PIN KHA
18	D1-7	A08359	7	DIODE, IN4001, 1 AMP, 50 VOLT
19	DISC1	A02345	1	DISCONNECT, 30 AMP, 3 POLE
20	DISC1 P/O	A02346	1	HANDLE, DISCONNECT
21	DISC1 P/O	610342-001	1	SHAFT, DISCONNECT, 7.1"
22	DISP1	611223	1	DISPLAY, OPERATOR, PV+1000
23	DRV1,2	611222	2	DRIVER, AC INVERTER, 220/240-50/60-3
24	ENCO1,2	611102	2	ENCODER, 1-3/8" THRU BORE
25	ENCO1,2 P/O	C06753-002	2	CABLE, SENSOR, M12, 5 WIRE, FEMALE
26	ENCL1	711816	1	ENCLOSURE, MAIN ELECTRICAL, SST
27	ENCL2	712625	1	ENCLOSURE, JUNCTION BOX, SST (611242)
28	ENCL3	C01040	1	ENCLOSURE, 4X4X3, SST
29	ENCL4,5	C01959	2	ENCLOSURE, 8X6X4, SST
30	ENCL4,5 P/O	C06575	2	PLATE, ENCLOSURE MOUNTING
31	FAN1-4	610747	4	FAN, MUFFIN, 24 VDC, TYPE 3
32	FAN1-4 P/O	610124	4	GUARD, FAN COVER
33	FAN5	C07060	1	FAN, MUFFIN, 24 VDC
34	FAN5 P/O	A06862	1	BRACKET, FAN MOUNTING
35	GND	C06488	1	LUG, GROUNDING
36	GND STRP	C07156	1	STRAP, DOOR GROUNDING, 24"
37	HTR1-3	611215	3	HEATER, 1000 WATT, 300 LB TANK
38	LT1	611226	1	LIGHT TREE, 24 V (GRN,YEL,BLU,RED,HORN)
39	M1	C06702-001	1	RELAY, MOTOR STARTER, 24 VDC
40	MTR1,2	610906	2	DRIVE SYSTEM, SANITARY PUMP
41	MTR3	611220	1	MOTOR, 115/208/230-50/60-1
42	MTR4	611198	1	PUMP, HOT WATER CIRCULATOR
43	OL1	C06678-001	1	RELAY, OVERLOAD, 3.7 – 12 AMP
44	PB1	C07213	1	SWITCH, PUSH/PULL, RED, MUSHROOM
45	PB1 P/O	C05395	1	NAMEPLATE, "PUSH-STOP / PULL-START"
46	PB1 P/O	C07101	1	CONTACT CARTRIDGE, NORMALLY CLOSED
47	PB2,3	C01246	2	SWITCH, PUSHBUTTON, YELLOW
48	PB2,3 P/O	C07091	2	NAMEPLATE, "SPRAY"

47572-WD ISSUE "A"

14.7 Standard Wiring Diagram, cont'd.

REF	SYMBOL	PART #	QTY	DESCRIPTION
49	PB2,3 P/O	C07102	2	CONTACT CARTRIDGE, NORMALLY OPEN
50	PLC1	611133	1	PLC, COMPACTLOGIX, PROCESSOR, 750K
51	PLC1 P/O	611134	1	PLC, COMPACTLOGIX, MEMORY CARD, 64MB
52	PLC1 P/O	611224	1	PLC, COMPACTLOGIX, DRIVE-COMM MODULE
53	PLC1 P/O	610882	1	PLC, COMPACTLOGIX, POWER SUPPLY, PB4
54	PLC1 P/O	611132	1	PLC, ML1500, HIGH SPEED COUNTER, 6 CHANNEL
55	PLC1 P/O	610657	1	PLC, ML1500, INPUT MODULE
56	PLC1 P/O	610632	2	PLC, ML1500, OUTPUT MODULE
57	PLC1 P/O	611225	1	PLC, COMPACTLOGIX, ANALOG MODULE
58	PLC1 P/O	610656	1	PLC, ML1500, THERMOCOUPLE MODULE, 6 CHANNEL
59	PLC1 P/O	610494	1	PLC, ML1500, END CAP
60	PLC1 P/O	611227	1	PLC, ETHERNET MODULE, HIRSCHMANN
61	PLC1 P/O	611228	1	PLC, ETHERNET PASS-THRU
62	PLC1 P/O	611229	1	PLC, ETHERNET CABLE, PASS-THRU
63	PNL1	711817	1	PANEL, MAIN ELECTRICAL, REWORKED
64	PNL2	712626	1	PANEL, JUNCTION BOX, REWORKED
65	PNL4	C01367	1	PANEL, JUNCTION BOX, REWORKED
66	PNL5	C06969	1	PANEL, JUNCTION BOX, REWORKED
67	PRS1,2	C06752-001	2	SENSOR, PROX, 80MM, 10-55 VDC, PNP, EDDY
68	PRS1,2 P/O	304153	2	CABLE, SENSOR, M12, 4 WIRE, FEMALE, STRAIGHT
69	PRS3-8	610151	6	SENSOR, PROX, 6.5MM, 10-30 VDC, PNP, N.O.
70	PRS9	611202	1	SENSOR, ULTRASONIC, DUAL-LEVEL, ANALOG
71	PRS9 P/O	304154	1	CABLE, SENSOR, M12, 4 WIRE, FEMALE, 90°
72	PS1,2	210467	2	SWITCH, PRESSURE TRANSDUCER, 1-1/2" SANITARY
73	PS1,2 P/O	610898	2	CABLE, SENSOR, M12, 3 WIRE, FEMALE, STRAIGHT
74	PSM1	304160	1	POWER SUPPLY, 110-220 TO 24 VDC, 10 AMP
75	SOL1-18	611230	18	VALVE, SOLENOID, 24 VDC, 3 PORT, 1/8" NPT
76	SOL1-18,25 P/O	A02349	19	CABLE, SENSOR, M8, 3 WIRE, FEMALE, STRAIGHT
77	SOL25	611218	1	VALVE, SOLENOID, 1/2" FLUID, AIR OPERATED, SST
78	TB1,4,5	C05843	240	TERMINAL, MARKER STRIP, BLANK
79	TB5 P/O	C06411	2	TERMINAL, JUMPER, 3 POSITION
80	TB1,4,5 P/O	C06461	95	TERMINAL, BLOCK, SINGLE LEVEL
81	TB1,4,5 P/O	C06462	3	TERMINAL, END COVER, SINGLE LEVEL
82	TB1,4 P/O	C06463	2.5	TERMINAL, JUMPER, 10 POSITION
83	TB1-5	C06464	84"	RAIL, DIN MOUNTING
84	TB1-5	C06465	11	TERMINAL, CLAMP, END ANCHOR
85	TB1,4,5 P/O	C06525	12	TERMINAL, GROUNDING
86	TB1,4 P/O	C07117	25	TERMINAL, BLOCK, DUAL LEVEL
87	TB1,4 P/O	C07118	2	TERMINAL, END COVER, DUAL LEVEL
88	TB6-8	610360	18"	RAIL, DIN MOUNTING, MINI
89	TB6-8 P/O	610361	75	TERMINAL, BLOCK, MINI
90	TB6-8 P/O	610362	9	TERMINAL, END COVER, MINI
91	TB6-8 P/O	610363	6	TERMINAL, CLAMP, END ANCHOR, MINI
92	TB6-8 P/O	610532	3	TERMINAL, JUMPER, 2 POSITION, MINI
93	TB6-8 P/O	610533	3	TERMINAL, JUMPER, 3 POSITION, MINI
94	TB6-8 P/O	610534	6	TERMINAL, GROUNDING, MINI
95	T/C1	611217	1	THERMOCOUPLE, TYPE K, 6" LONG
96	-----	C07186	0.25	TERMINAL, BREAK-A-PART, MEDIUM
97	-----	610967	3.50	TERMINAL, BREAK-A-PART, MINI

47572-WD ISSUE "A"

