

REVISIONS				
ZONE	REV	DESCRIPTION	DATE	APPROVED
	C	CAD ORIGINAL	03/10/00	

ITEM	PART NO.	DESCRIPTION	REQ'D	M/P
1	7781-2	CUP DISPENSER PLATE	1	M
2	5/16-18	FLEX NUT	24	M
3	53522-7.4375	DISPENSER GUIDE ROD 7-7/16	12	M
4	53522-48.5	DISPENSER GUIDE ROD 48-1/2	12	M
5	53504	CONNECTING SHAFT	1	M
6	FB 810-7	FLANGED BUSHING 1/2 x 5/8 x 7/8	1	P
7	53512-1	CONNECTING BLOCK	1	M
8	FCP2	FLOW CONTROL	2	P
9	KQ2H07-35S	STRAIGHT CONNECTOR 1/4 x 1/4	2	P
10	53503-1	PIVOT BRACKET	1	M
11	53501-5.564	END BRACKET	1	M
12	53505-27.250	GEAR RACK 27-1/4	2	M
13	53510-1350-1874	SINGLE SPIRAL R.H.	12	M
14	53511-1350-1874	SINGLE SPIRAL L.H.	12	M
15	53520-1.590	SPIRAL SHAFT	24	M
16	53521	SPIRAL FLAT WASHER	24	M
17	FB 68-5	FLANGED BUSHING 3/8 x 1/2 x 5/8	48	P
18	53501-5.564	END BRACKET DRIVE SIDE	1	M
19	53508	END BRACKET WEAR BOTTOM	4	M
20	SR-172-DP	ROUND AIR CYLINDER	1	P
21	53513	DISPENSER RACK GUIDE	4	M

Z	Zitropack, Ltd.			
	TEL: 630-766-7015 FAX: 630-766-7211 E-MAIL: ZITROPACK@AOL.COM			
6 LANE CUP DISPENSER				
SERIAL # 2010	SIZE C	NAME R.O.	MFG NO. 600-2010	REV A
MACHINE MODEL Z-60M		SCALE	SHEET 1 OF 1	

This drawing and all information herein is the property of Zitropack, Ltd.

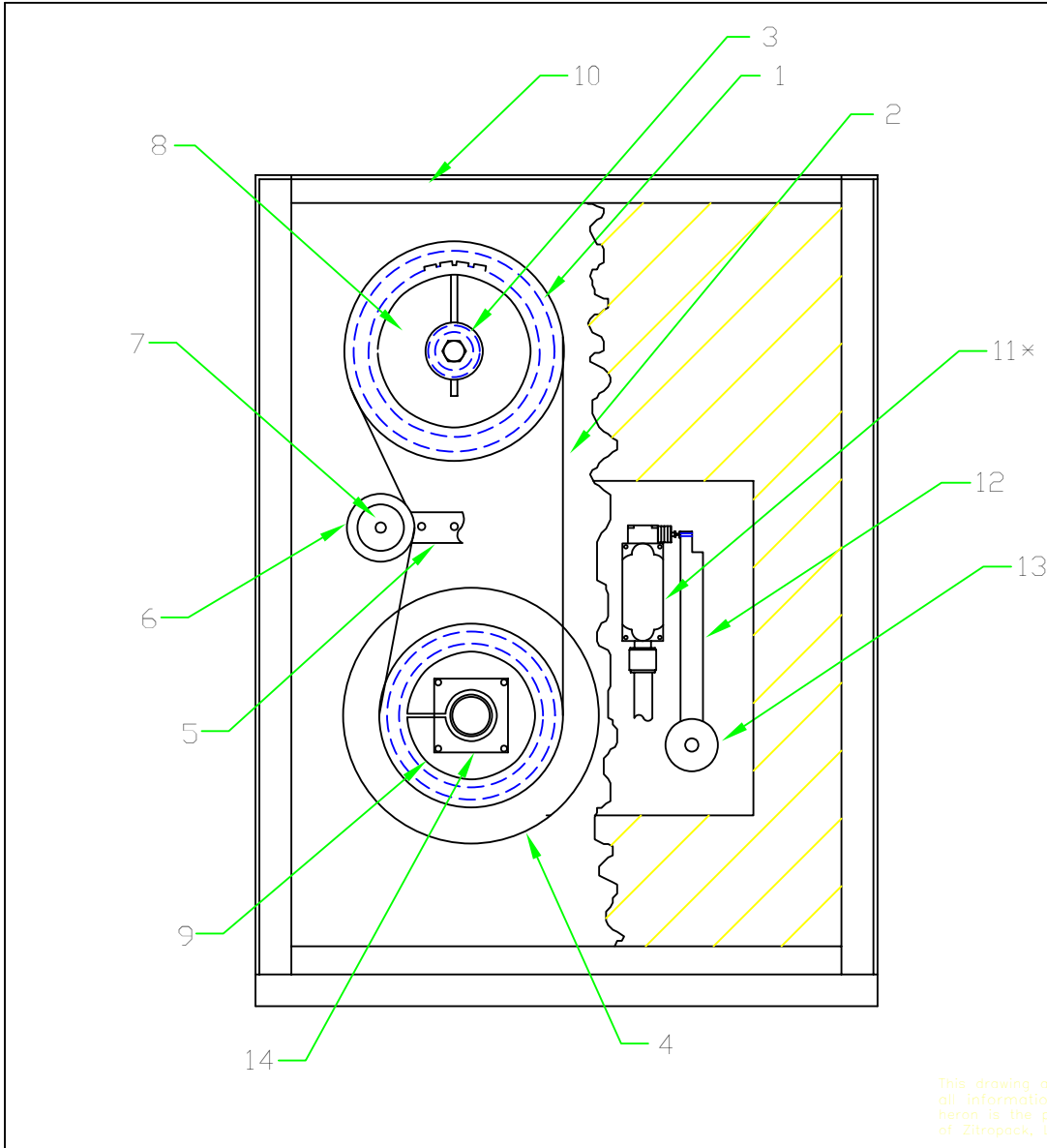

REVISIONS				
ZONE	REV	DESCRIPTION	DATE	APPROVED
X-X	A	CAD ORIGINAL	06/02/98	

ITEM	PART NO.	DESCRIPTION	REQ'D	M/P
1	30XH200E	TIMING PULLEY	1	P
2	630XH200	TIMING BELT	1	P
3	51640	CONVEYOR SPROCKET WASHER	1	M
4	24XH200-SF	TIMING PULLEY BOTTOM	1	P
5	81637	TIGHTNER ROLLER BRACKET	1	M
6	81636	TIMING BELT IDLER ROLLER	1	M
7	62072RS	SKF BEARING	1	P
8	E 1-3/8 QD	TAPER LOCK	1	P
9	SFX-1 3/8 QD	TAPER LOCK	1	P
10	81609	FRAME BAR	2	M
11	4LS1	OVERLOAD MICROSWITCH	1	P
12	51633	DETECTOR ARM	1	M
13	81630	OVERLOAD ARM HOUSING	1	M
14	CFC-22	FLANGED BEARING 1 3/8 (INDEXER)	1	P

\* MICROSWITCH IS LOCATED ON THE GEAR BOX

SIDE VIEW

Z	Zitropack, Ltd.			
	TEL:630-766-1016 FAX:630-766-7211 E-MAIL: ZITROPACK@ADL.COM			
CONVEYOR DRIVE SPROCKET				
SERIAL # 2010	SIZE B	NAME R.O.	DWG NO. 1142-3	REV A
MACHINE: Z-6000	SCALE	SHEET 1 OF 1		

This drawing and all information herein is the property of Zitropack, LTD.

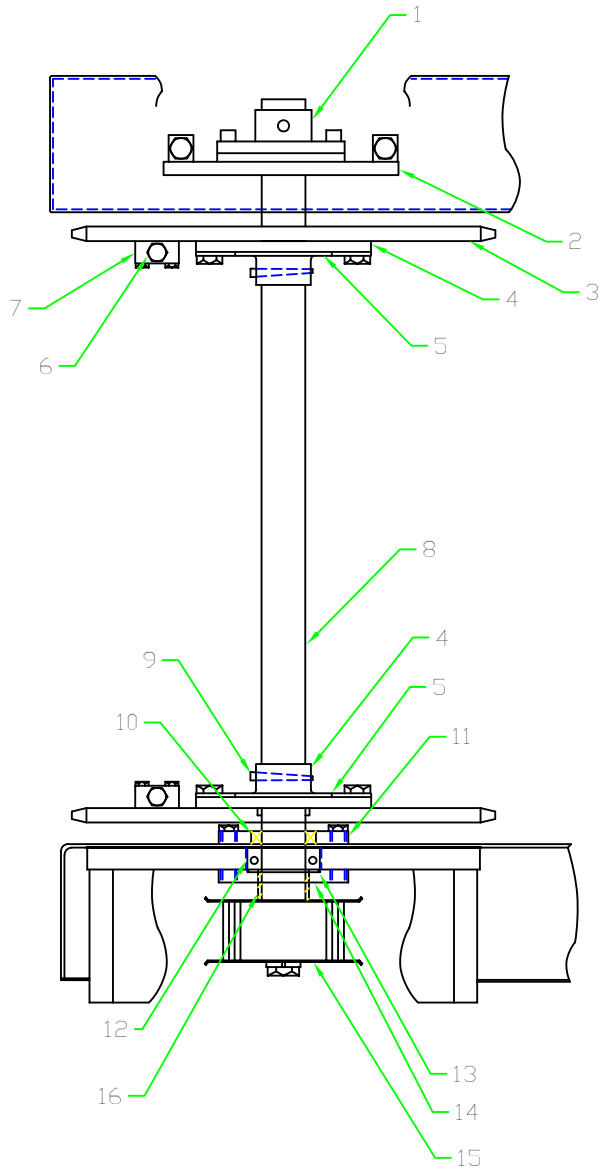

REVISIONS				
ZONE	REV	DESCRIPTION	DATE	APPROVED
X-X	A	CAD ORIGINAL	05/29/98	

ITEM	PART NO.	DESCRIPTION	REQ'D	M/P
1	SFC-20	SET SCREW MOUNTED BEARING	1	P
2	51130	CONVEYOR DRIVE WELDMENT	1	M
3	51607	CONVEYOR DRIVE SPROCKET	2	M
4	51602	CONVEYOR DRIVE HUB	2	M
5	51604	CONVEYOR CLAMP RING	2	M
6	51605	ADJUSTMENT LOCKING BOLT	4	M
7	51606	THREADED ADJUSTMENT BLOCK	4	M
8	81600	CONVEYOR DRIVE SHAFT	1	M
9	#6-3.5	TAPER PIN	2	P
10	14960	OIL SEAL 1 1/2 x 2 1/4 x 1/4	2	P
11	51601	SEAL HOUSING	1	M
12	62072RS1	BEARING 1.378 x 2.835 x .670	2	P
13	231	O-RING 2 5/8 x 2 7/8 x 1/8	1	P
14	81644	BEARING RETAINER	1	M
15	24XH200SF	TIMING PULLEY	1	P
16	81646	BELT TIGHTENER BLOCK	1	M

TOP VIEW

Z	Zitropack, Ltd.			
	TEL:630-766-1016 FAX:630-766-7211 E-MAIL: ZITROPACK@AOL.COM			
CONVEYOR DRIVE SPROCKET				
SERIAL# 2010	SIZE B	NAME R.O.	DWG NO. 1142-3	REV A
MACHINE: Z-6000	SCALE	SHEET 1 OF 1		

This drawing and all information herein is the property of Zitropack, LTD.

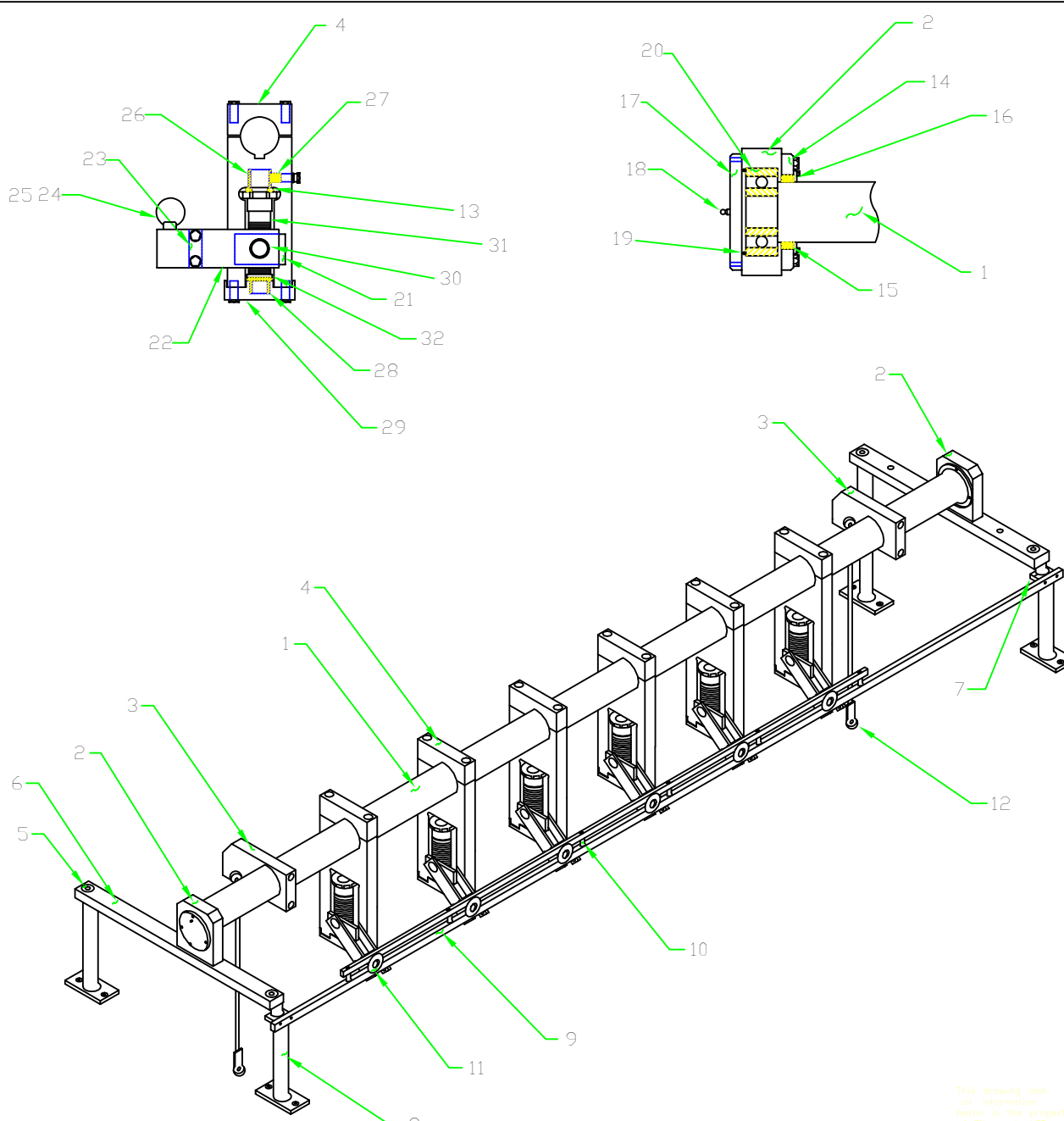

REVISIONS				
ZONE	REV.	DESCRIPTION	DATE	APPROVED
X=X	A	CAD ORIGINAL	05/14/98	

NUMBER	DESCRIPTION	PART NO.	REQ'D
1	PISTON DRIVE SHAFT	52186	1
2	PUMP DRIVE BEARING BLOCK	52183	2
3	PISTON DRIVE ARM	52195	2
4	PISTON ADJUSTMENT ARM ASSEMBLY	52197	6
5	HTD POST HEAVY WASHER	52248	4
6	PISTON DRIVE MTG. BAR	52211	2
7	POST CLAMP	52185	2
8	PUMP DRIVE MTG. POST	52209	4
9	PISTON GUIDE BAR	52249	1
10	GUIDE BAR STUD	52213	6
11	PISTON GUIDE SLEEVE	52214	6
12	FEMALE ROD END	KW102	4
13	THRUST WASHER	52208	6
14	SEAL CAP	52181	2
15	OIL SEAL	14939	2
16	FLAN DRIVER	52182	2
17	BEARING CAP	52180	2
18	STRAIGHT GREASE FITTING	1/4-28-3	1
19	O-RING 2 1/2 x 2 3/4 x 1/8	230	2
20	SELF-ALIGNMENT BEARING	7306 WN	4
21	ADJUSTMENT VOLUME BLOCK	52199	6
22	CONNECTING LINK	52206	6
23	CONNECTING LINK SPACER BLOCK	52247	6
24	LINK BUSHING	52246	12
25	QUICK RELEASE PIN	28404A500	6
26	PLAIN BUSHING 7/16 x 2/16 x 5/8	B 79-5	6
27	RICTION BOTTOM	52208	6
28	FLANGED BUSHING 1/2 x 3/8 x 7/8	FB 810-7	6
29	PISTON ARM BOTTOM BLOCK	52245	6
30	FLANGED BUSHING 3/8 x 1/4 x 1/2	FB 1012-4	12
31	ADJUSTING HANDWHEEL	52201	6
32	BACK-UP WASHER	52203	6

This drawing and all information herein is the property of Zitropack, Ltd.

<b>TOLERANCES</b> Unless otherwise specified:  Fraction $\pm .015$ Decimal $\pm .005$ Angle $\pm .1^\circ$	Zitropack, Ltd.			
	TEL: 630-765-0016 FAX: 630-765-7251 E-MAIL: ZIT@PACKMAIL.COM <b>UPPER PUMP DRIVE ASSEMBLY</b>			
SERIAL # 2010	SIZE C	DATE R.O.	REV NO. 5200	REV A
ISSUE NO. 2-98	SCALE	SHEET	OF 1	

REVISED				
ZONE	REV	DESCRIPTION	DATE	APPROVED
X-X	A	CAD ORIGINAL	05/28/98	

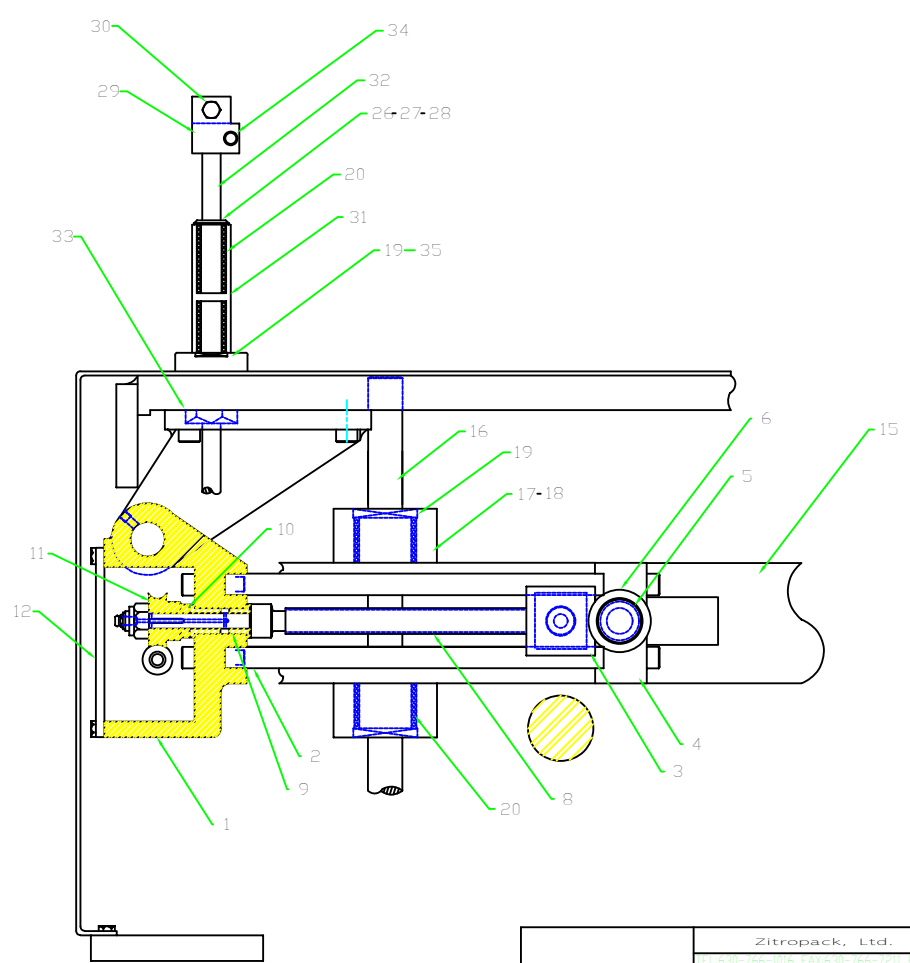
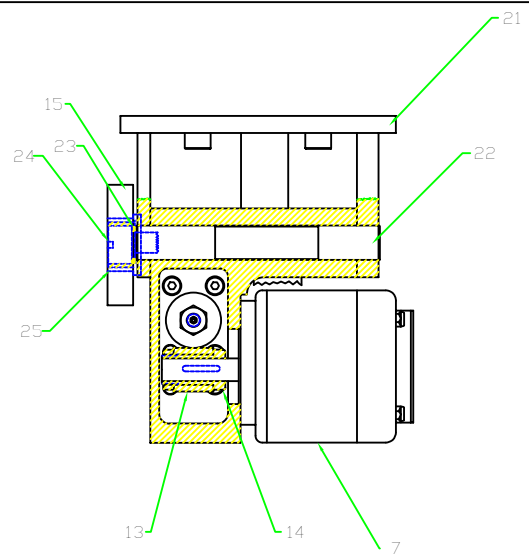

NUMBER	DESCRIPTION	PART NO.	REQ'D	M/P
1	VOLUME CONTROL CASTING	52109	1	M
2	END PLATE PUMP	52110	2	M
3	ADJUSTING PIVOT	52111	1	M
4	VOLUME CONTROL END PLATE	52112	1	M
5	PUMP CAM SPACER	52113	1	M
6	CAM FOLLOWER	CF-1 3/4 SR	1	P
7	MOTOR DRIVE ASSEMBLY	52114	1	M
8	VOLUME CONTROL SHAFT	52117	1	M
9	FLANGED BUSHING 3/8 x 7/8 x 5/8	FB 1014-5	2	P
10	VOLUME CONTROL SPACER	52118	1	M
11	VOLUME CONTROL WORM GEAR	D 1600	1	P
12	CASTING COVER	52119	1	M
13	WORM GEAR RH	D 1607K	1	P
14	MOTOR WORM BUSHING	52115	1	M
15	PUMP BUSHING PLATE	52106	1	M
16	THOMSON ROD	51180-18	1	M
17	PUMP BUSHING BLOCK	52104	2	M
18	BEARING SPACER	52105	2	M
19	OIL SEAL	9235	6	P
20	1" BALL BEARING	B 162936	8	P
21	PIVOT BRACKET	52120	1	M
22	PUMP DRIVE PIVOT SHAFT	52108	1	M
23	CAM FOLLOWER SPACER	52124	1	M
24	CAM FOLLOWER	CF-1 3/4 SR	1	P
25	SLIDE BLOCK	52106	1	M
26	O-RING 1 x 1 1/4 x 1/8	214	2	P
27	OIL SEAL	S-1000	2	M
28	UPRIGHT SEAL CAP	51142	2	M
29	PISTON DRIVE CLAVIS	52191	2	M
30	LOWER ROD END BOLT	52193	2	M
31	BEARING HOUSING	51115	2	M
32	PISTON DRIVE SHAFT	51180-20.5	2	M
33	HEX NUT 2"	51143	2	M
34	ROD LOCK	10185	2	M
34	INTERNAL RETAINING RING	HD-162-S1P	2	P

This drawing and all information herein is the property of Zitropack, Ltd.

Z	Zitropack, Ltd.			
	TEL: 630-766-0000 FAX: 630-766-7231 E-MAIL: ZIT@PACKMAIL.COM			
LOWER PUMP DRIVE ASSEMBLY				
SERIAL# 2010	SIZE C	DATE R.O.	DWG NO. 5201	REV A
MACHINE MODEL Z-600	SCALE		SHEET	OF 1

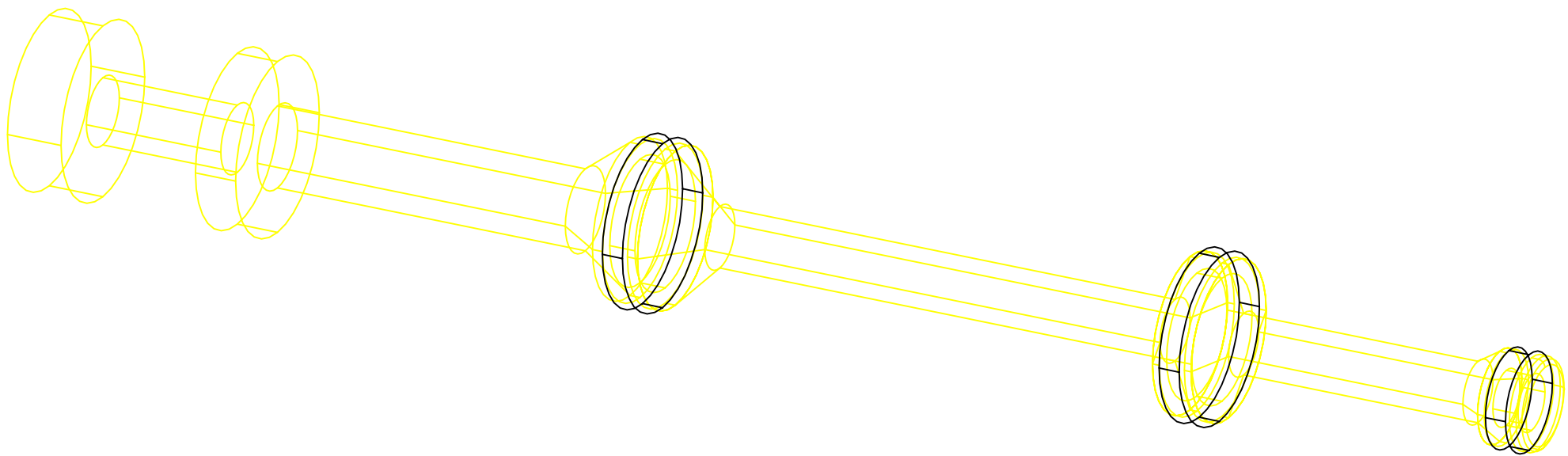

REVISIONS				
ZONE	REV	DESCRIPTION	DATE	APPROVED
	A	CAD ORIGINAL	03/31/98	

ITEM	DESCRIPTION	PART#	REQ'D
1	O-RING 1/2 x 7/8 x 3/16	310	1
2	O-RING 1 1/8 x 1 1/2 x 3/16	320	2
3	STEM SHAFT	5807	1

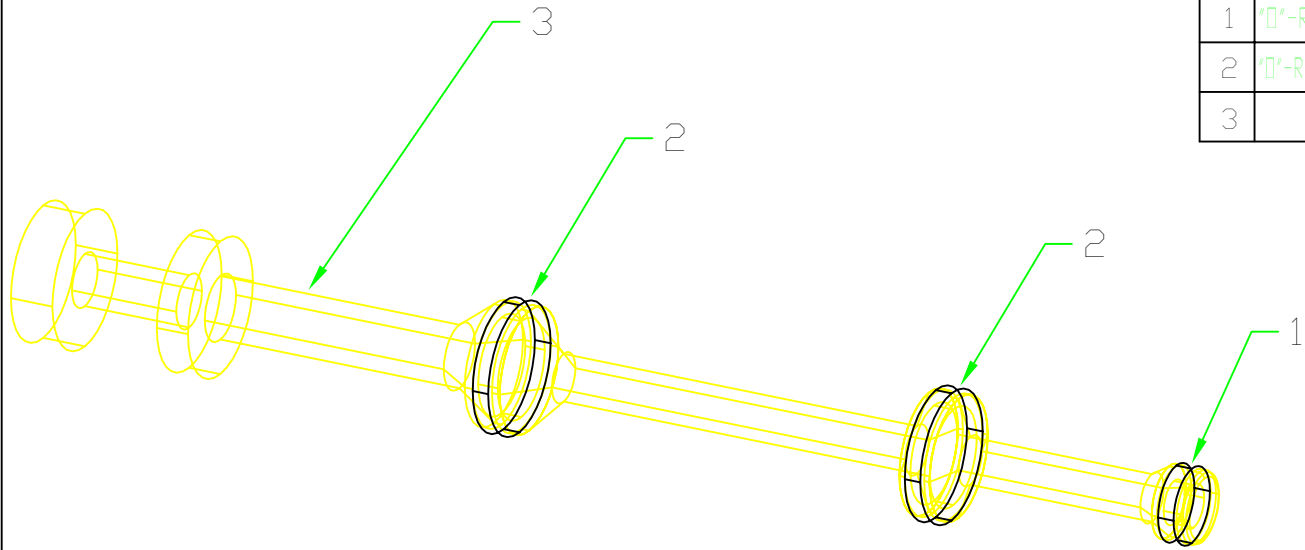

THIS DRAWING AND ALL INFORMATION HEREON IS THE PROPERTY OF ZITROPACK, LTD.

Z	ZITROPACK, LTD.			
	TEL: 630-766-1015 FAX: 630-766-7211 E-MAIL: ZITROPACK@AOL.COM			
STEM SHAFT ASSEMBLY				
MACHINE MODEL: Z-6000	R	R.O.	5807	A
SERIAL NUMBER: 2011	NONE			



REVISIONS				
ZONE	REV.	DESCRIPTION	DATE	APPROVED
	B	CAD ORIGINAL	06/10/96	

ITEM	DESCRIPTION	PART NO.
1	PISTON SHAFT	6006
2	PISTON HUB	6005
3	LOCK PIN 5/16 x 1 3/16	606
4	1 1/4 x 1 1/2 x 1/8	218
5	1 1/4 x 1 5/8 x 3/16	322
6	1/2 x 3/4 x 1/8	206

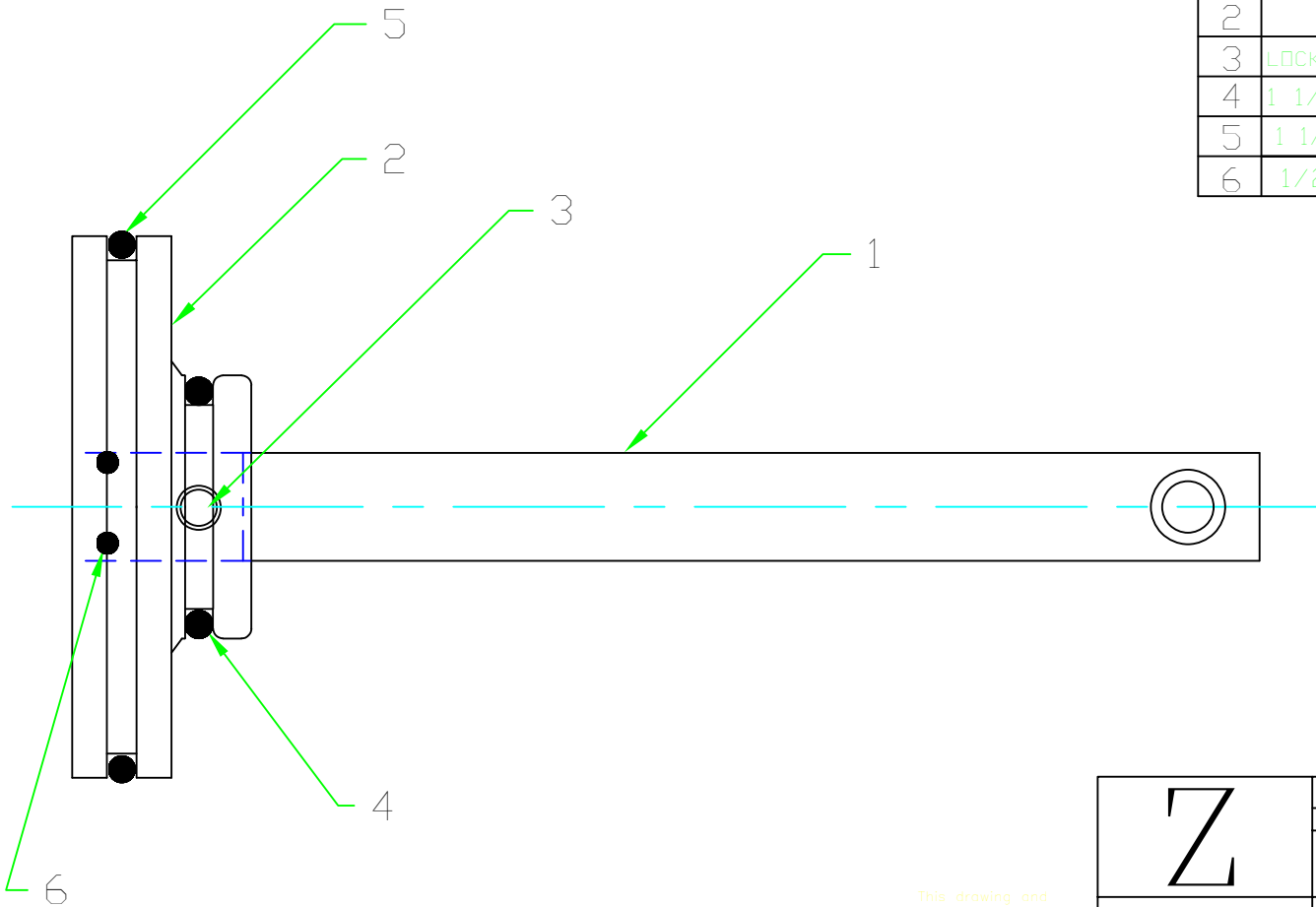

This drawing and all information herein is the property of Zitropack, LTD.

<b>Z</b>	Zitropack, Ltd.			
	TEL:630-766-1016 FAX:630-766-7211 E-MAIL: ZITROPACK@AOL.COM			
PISTON SHAFT ASSEMBLY				
SERIAL# 2010	SIZE B	NAME R.O.	DWG NO. 6004	REV A
MACHINE MODEL: Z-8000	SCALE		SHEET	1 OF 1

REVISIONS				
ZONE	REV	DESCRIPTION	DATE	APPROVED
X-X	A	CAD ORIGINAL	07/21/98	

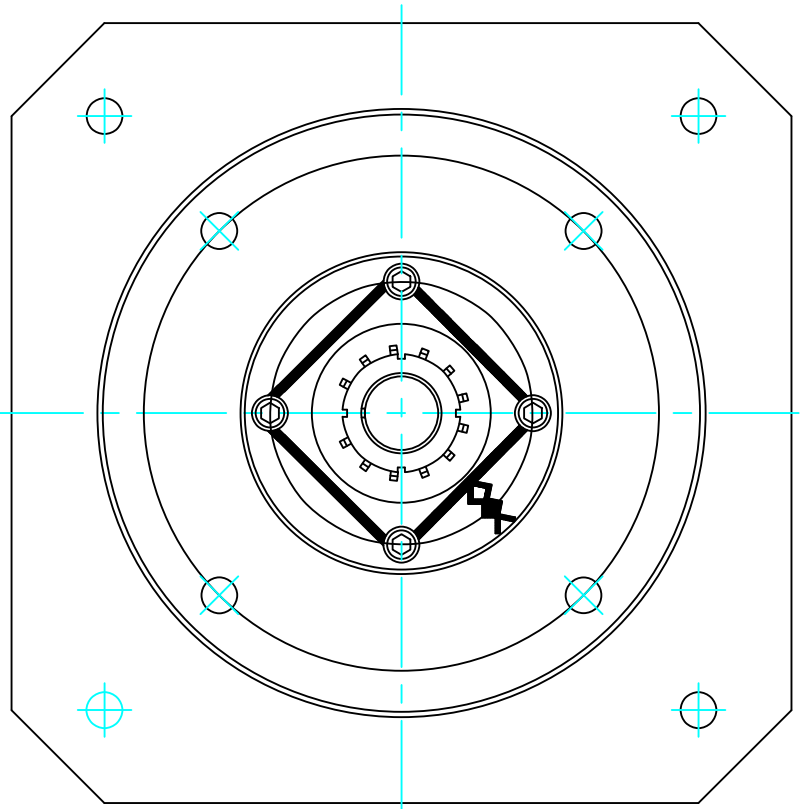
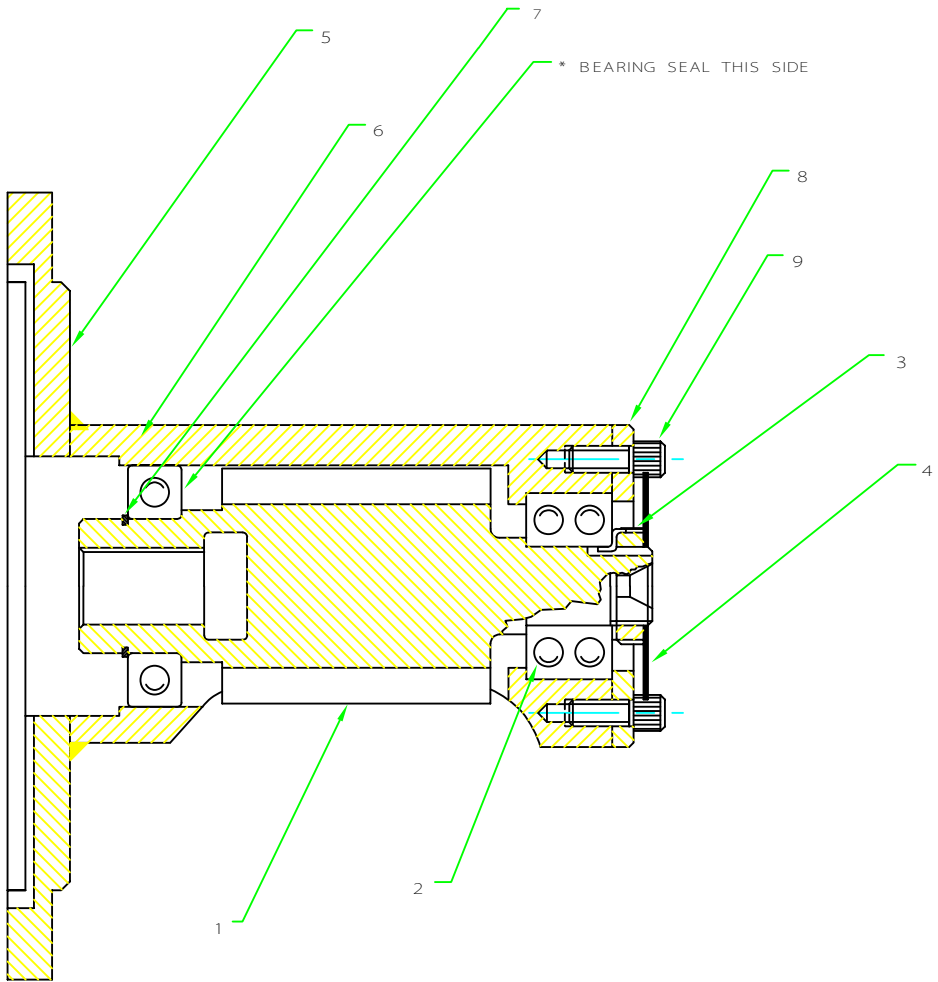

PART NO.	DESCRIPTION
51518	DRIVE WORM
5306CZZ	DOUBLE BEARING
W-06	LOCK WASHER
N-06	LOCK NUT
51519	MOTOR WORM PLATE
50112RS	SKF BEARING 2.1654 x 3.5433 x .7087
H 215ST PA	EXTERNAL RETAINING RING 1.993 I.D.
51520	WORM BEARING CAP
51521	BEARING CAP SCREW

This drawing and all information herein is the property of Zitropack, LTD

<h1>Z</h1>	Zitropack, Ltd.		
	TEL: 630-766-1016 FAX: 630-766-7211 E-MAIL: ZITROPACK@AOL.COM		
<h2>WORM SHAFT DRIVE</h2>			
SERIAL# 2010	SIZE <b>B</b>	NAME <b>R.O.</b>	DWG NO. 51517
MACHINE MODEL: Z-6000	SCALE	SHEET	1 OF 1

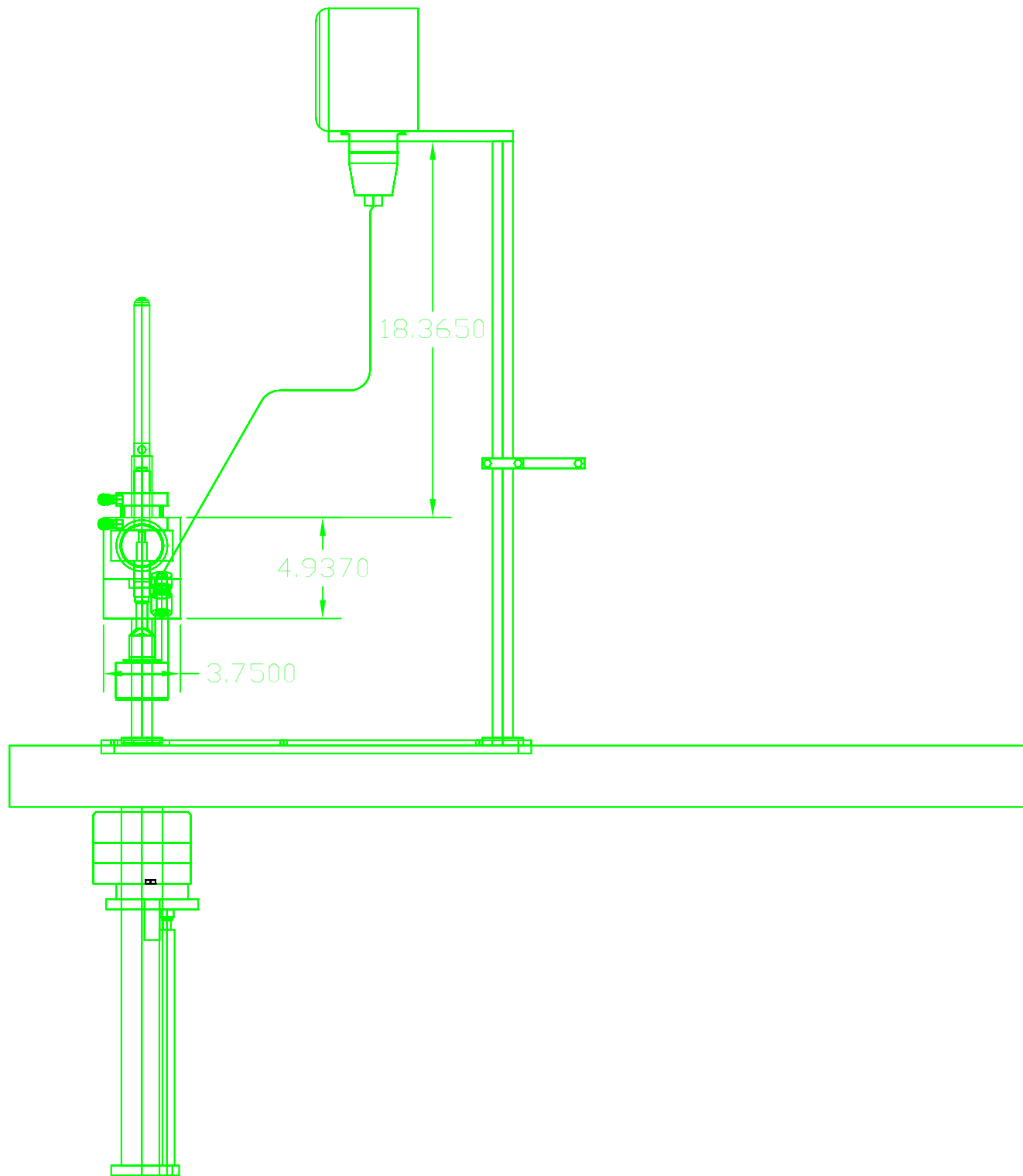

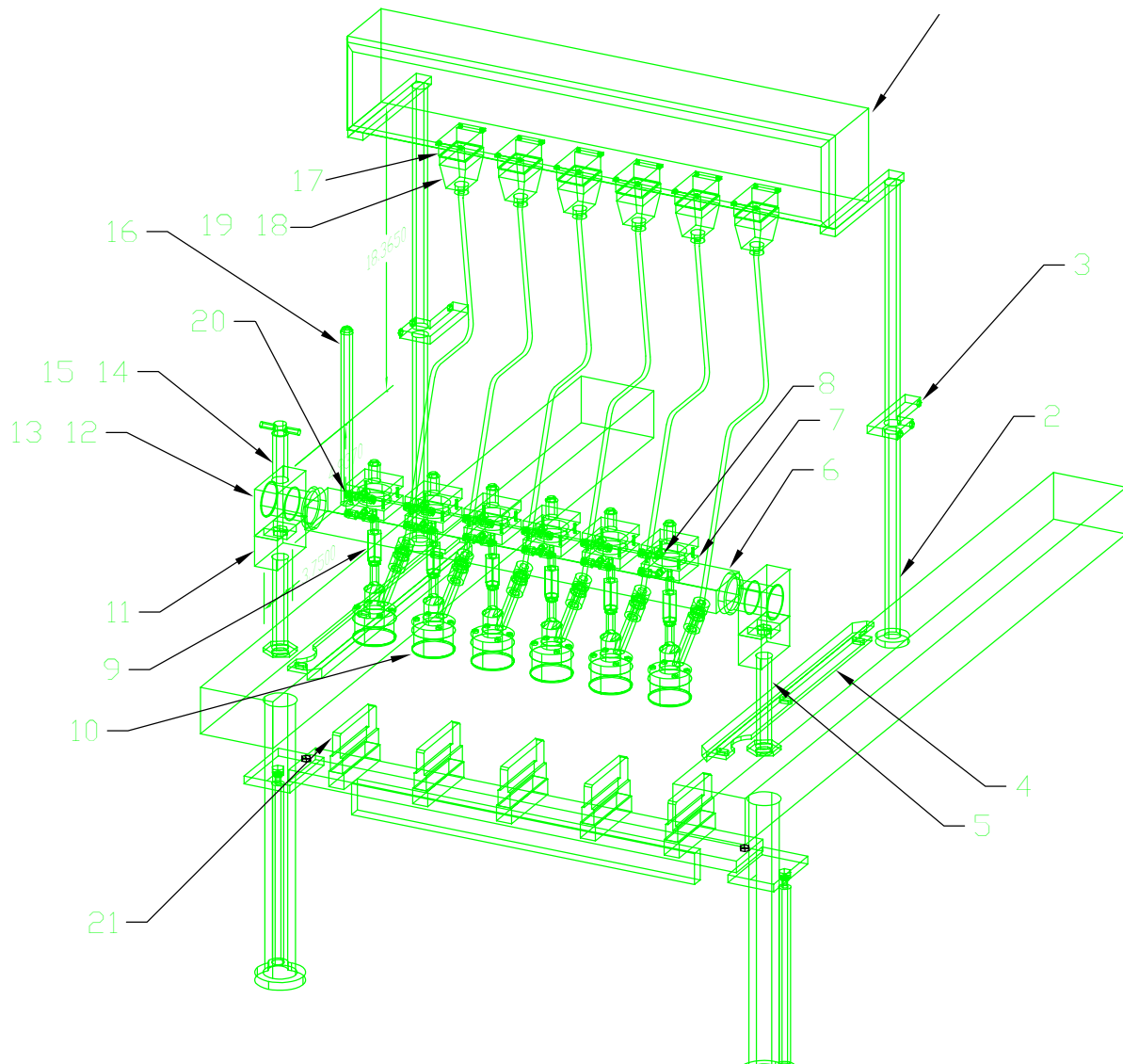

ITEM	PART NO.
1	61357
2	81362
3	82822
4	81648
5	1-32.75-S
6	62820-10
7	FP-313
8	KQ2L07-34S
9	8220
10	62920-10
11	82808
12	82809
13	CB-3236-24-M
14	82810
15	82811
16	82818
17	H-BE 10.0030
18	HUB13 10.0110
19	HB-E 10.1900
20	KQ2L07-34S
21	5830

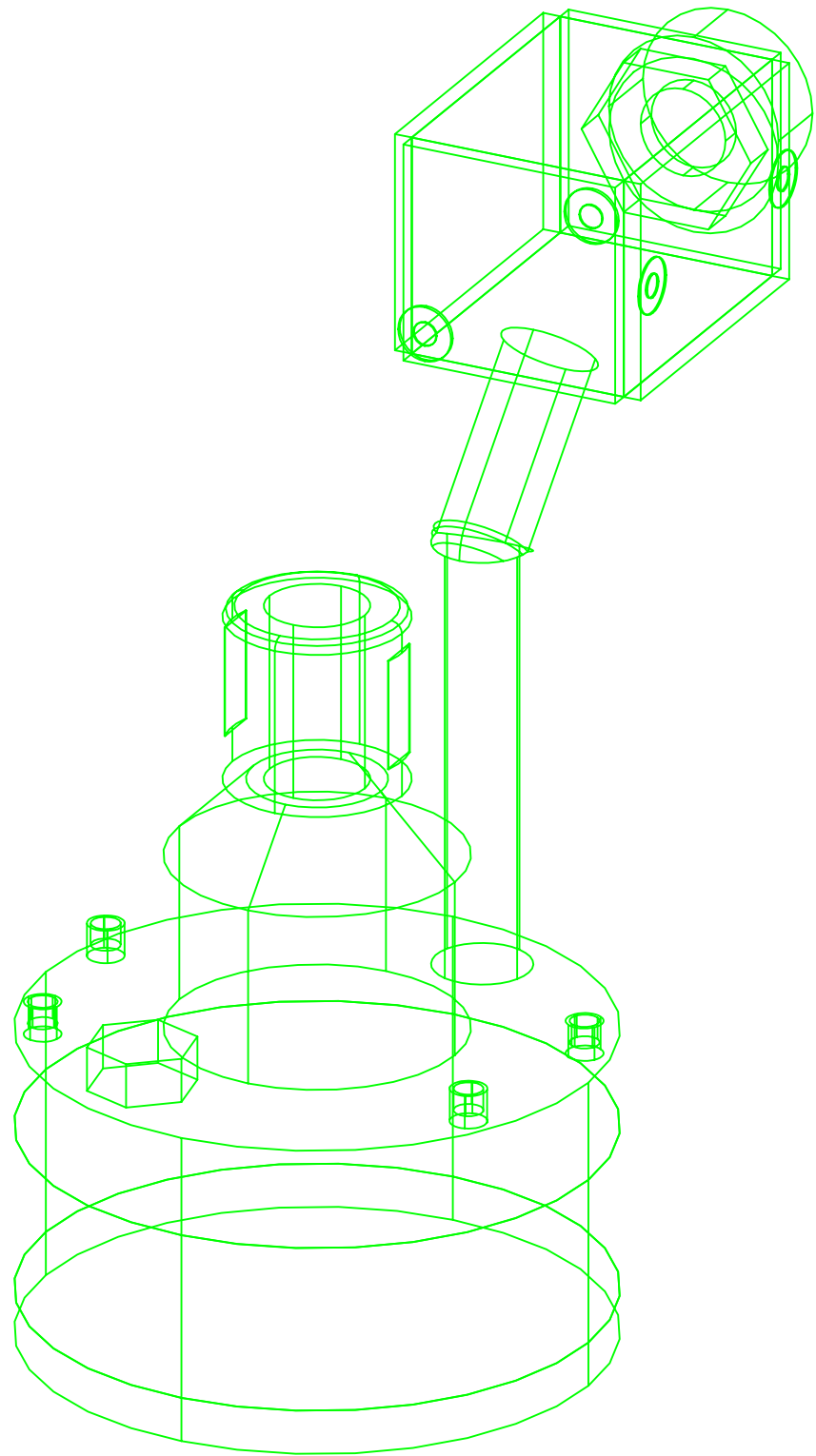

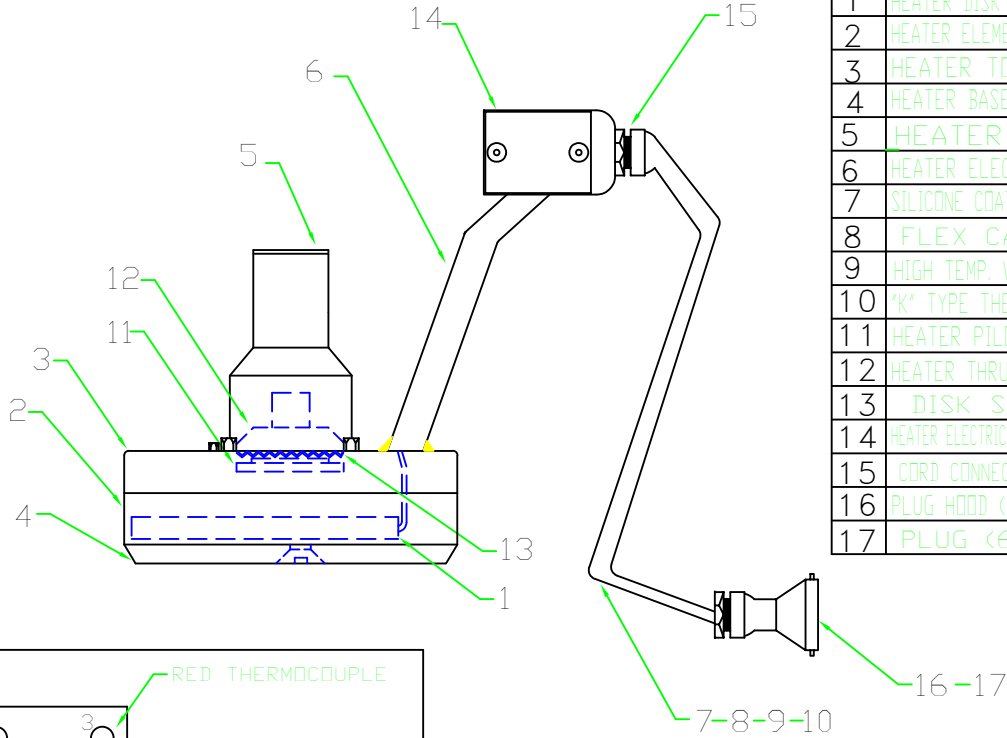
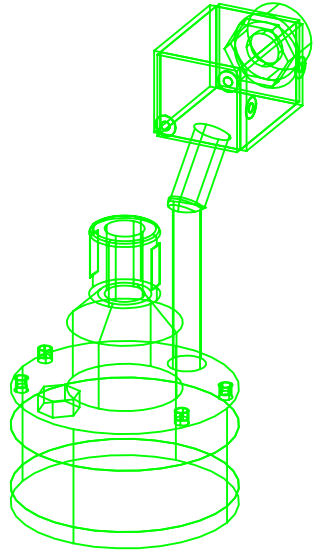

REVISIONS				
ZONE	REV	DESCRIPTION	DATE	APPROVED
	B	CAD ORIGINAL	03/04/97	

ITEM	DESCRIPTION	PART NO.
1	HEATER DISK 240v 300w	241-600031-005 A-00 VW
2	HEATER ELEMENT HOUSING	62922
3	HEATER TOP PLATE	82923-3.100
4	HEATER BASE ASSEMBLY	82921-3.100-4140-S
5	HEATER SHAFT	82924-1/2-20
6	HEATER ELECTRIC STUD	5903
7	SILICONE COATED SLEEVE	8772K524
8	FLEX CABLE	54915K48
9	HIGH TEMP. WIRE 16 GA	116-616
10	K* TYPE THERMOCOUPLE	RS10-0-B36K
11	HEATER PILOT SLEEVE	62927
12	HEATER THRUST WASHER	5843-1.5
13	DISK SPRING	9713K86-1.5
14	HEATER ELECTRIC STUD HOUSING	DA6391-1
15	CORD CONNECTOR ST-13	12.9902
16	PLUG HOOD (TOP ENTRY)	HUB 13 10.0110
17	PLUG (6 PINS)	HB-E 10.1900

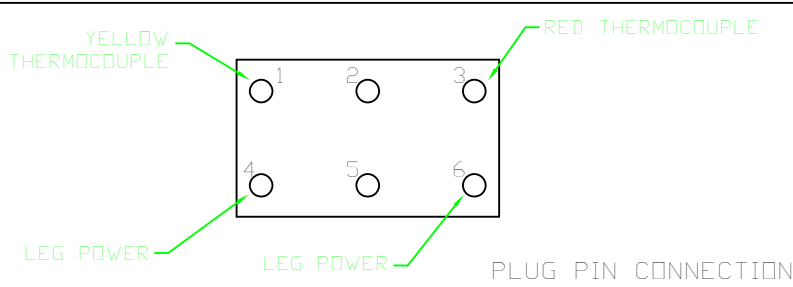

This drawing and all information hereon is the property of Zitropack, LTD

<b>Z</b>	Zitropack, Ltd.			
	TEL: 630-766-0005 FAX: 630-766-7200 E-MAIL: ZITROPACK@AOL.COM			
<b>HEATER HEAD ASSEMBLY</b>				
SERIAL# 2010	NAME R.O.	DWG NO. 62920-2010	REV A	
MACHINE MODEL: Z-6000			PAGE 1 OF 1	

REVISIONS				
ZONE	REV	DESCRIPTION	DATE	APPROVED
X-X	A	CAD ORIGINAL	11/04/98	

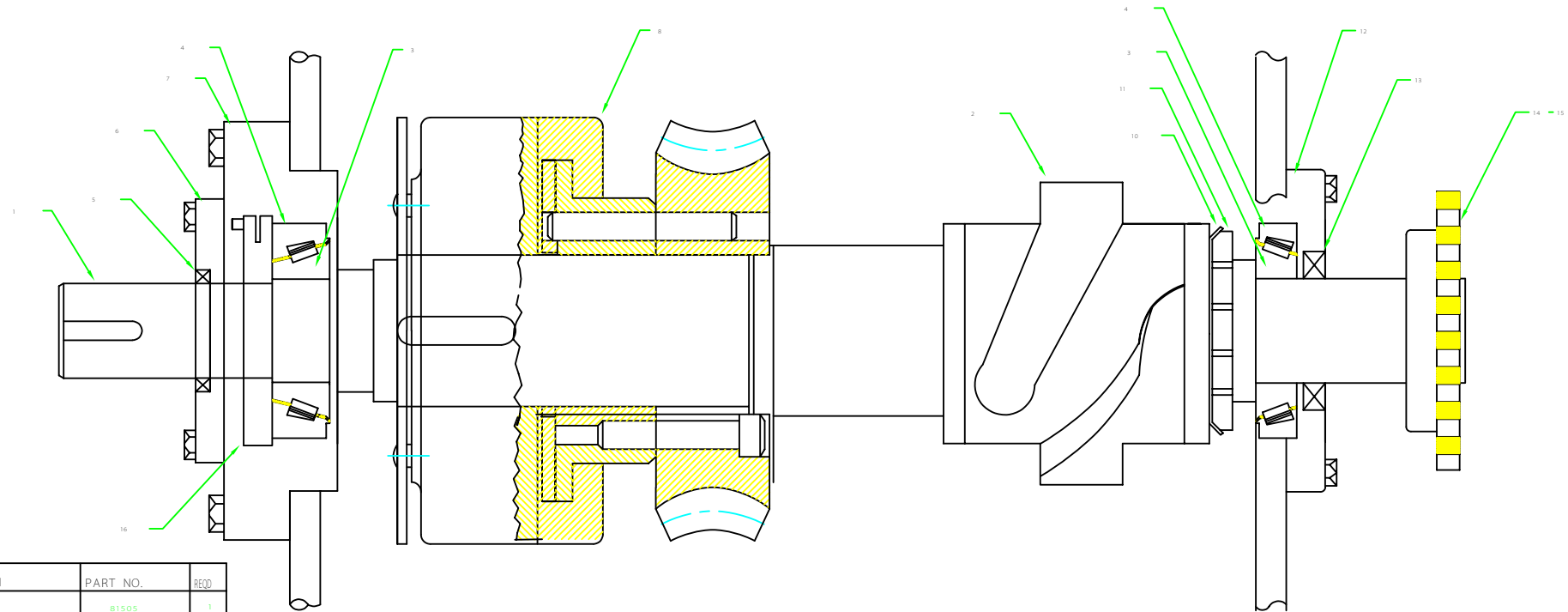

ITEM	DESCRIPTION	PART NO.	REQD.
1	DRIVE SHAFT	81505	1
2	INDEXER CAM	756150-LH	1
3	CONE BEARING	527-S	2
4	CUP BEARING	520-X	2
5	SEAL 1 3/4 x 2 3/4 x 5/16	CR 17523	1
6	SEAL CAP	81530	1
7	OUTPUT BEARING HOUSING	81528	1
8	OVERLOAD CLUTCH	51507	1
9			
10	LOCK WASHER	W-14	1
11	LOCK NUT	N-14	1
12	INPUT BEARING HOUSING	81531	1
13	SEAL 1 3/4 x 2 3/4 x 5/16	CR 17523	1
14	CHAIN COUPLING SPROCKET	6020H	1
15	TAPER LOCK	2012-1 3/4	1
16	BEARING LOCK NUT	81529	1

This drawing and all information herein is the property of Zitropack, Ltd.

<h1>Z</h1>	Zitropack, Ltd.			
	TEL: 630-766-1016 FAX: 630-766-7211 E-MAIL: ZITROPACK@AOL.COM			
GEAR BOX DRIVE SHAFT ASSEMBLY				
SERIAL# 2010	SIZE	NAME	ENG. NO.	REV.
MACHINE MODEL: Z-6000	B	R.O.	81504	A
SCALE			SHEET	1 OF 1

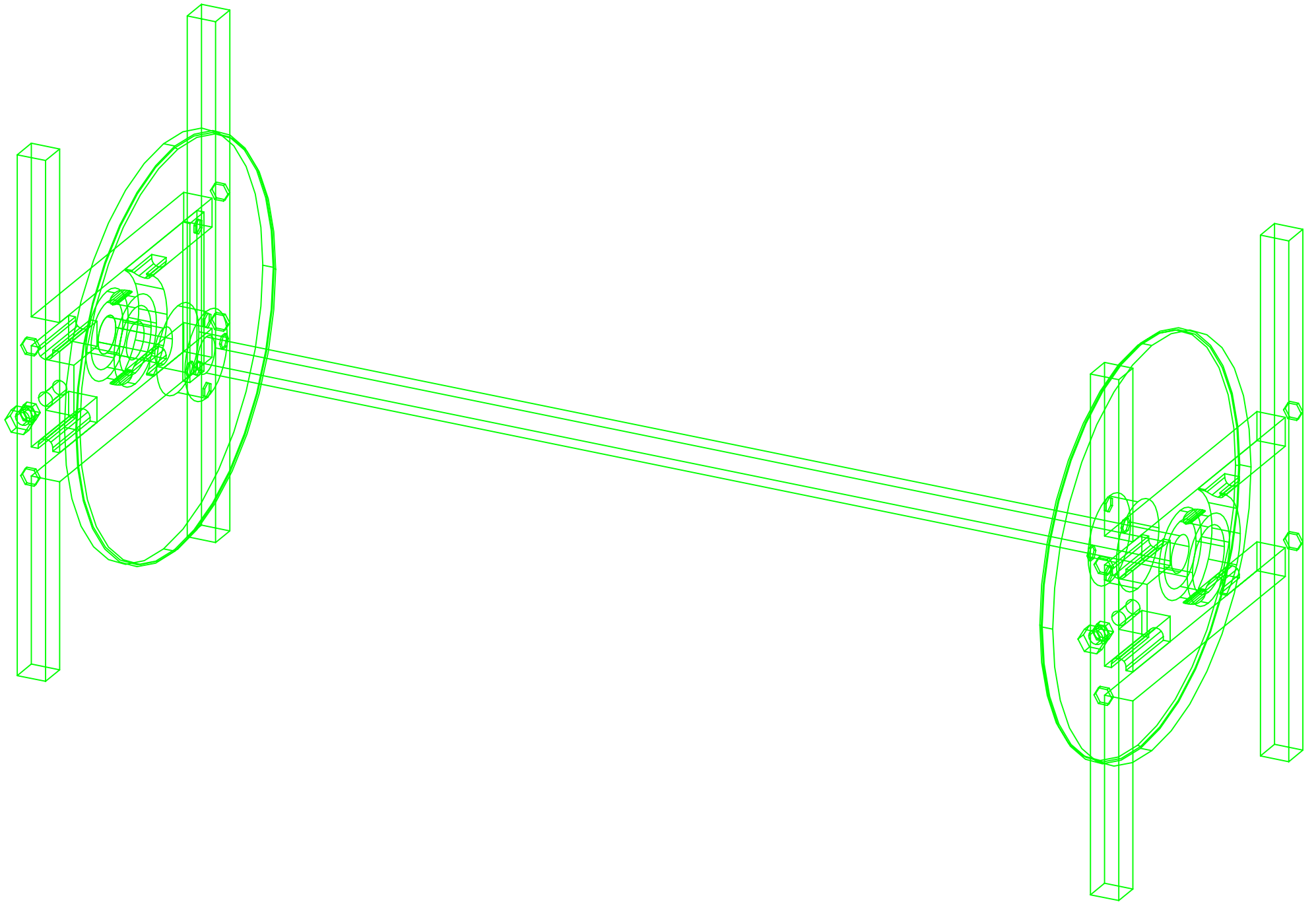



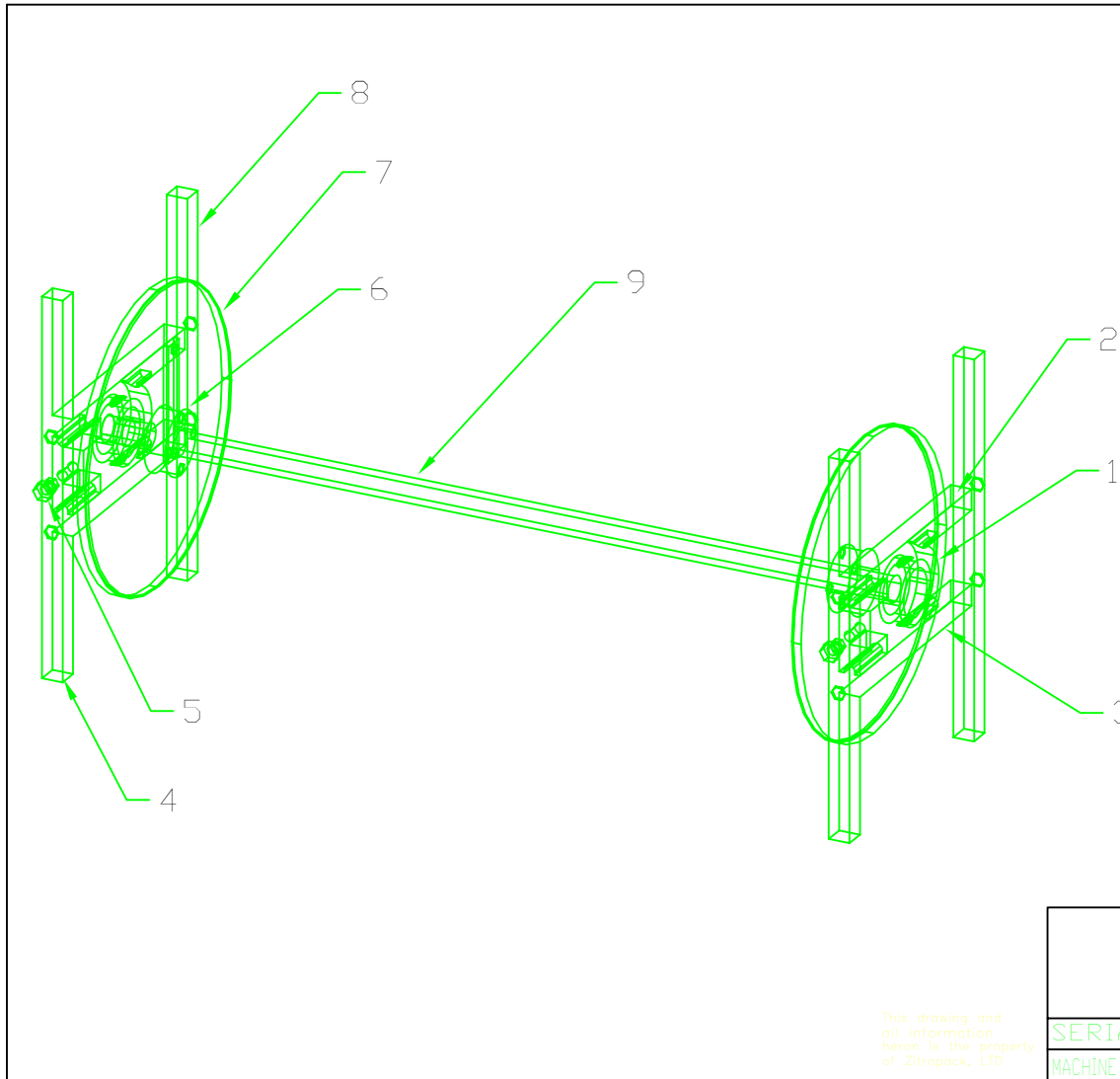

REVISIONS				
ZONE	REV	DESCRIPTION	DATE	APPROVED
	B	CAD ORIGINAL	02/02/99	

ITEM	DESCRIPTION	PART NUMBER	REQD
1	TAKE-UP BEARING	MB 25 1 1/4 PIN	2
2	BEARING BAR UPPER	51703	2
3	BEARING BAR LOWER	51702	2
4	TAKE-UP INSIDE POST	51701	2
5	IDLER TIGHTNER BOLT	81706	2
6	IDLER SPROCKET FLANGE	51707	2
7	IDLER DISK	81708	2
8	TAKE-UP END POST	51700	2
9	SPROCKET SHAFT	51704	1

This drawing and all information herein is the property of Zitropack, LTD

Z	Zitropack, Ltd.			
	TEL:630-766-1015 FAX:630-766-7211 E-MAIL: ZITROPACK@AOL.COM			
TAKE-UP ASSEMBLY				
SERIAL# 2010	SIZE B	NAME R.O.	DWG NO. 81700	REV A
MACHINE MODEL: Z-6000			SHEET	1 OF 1

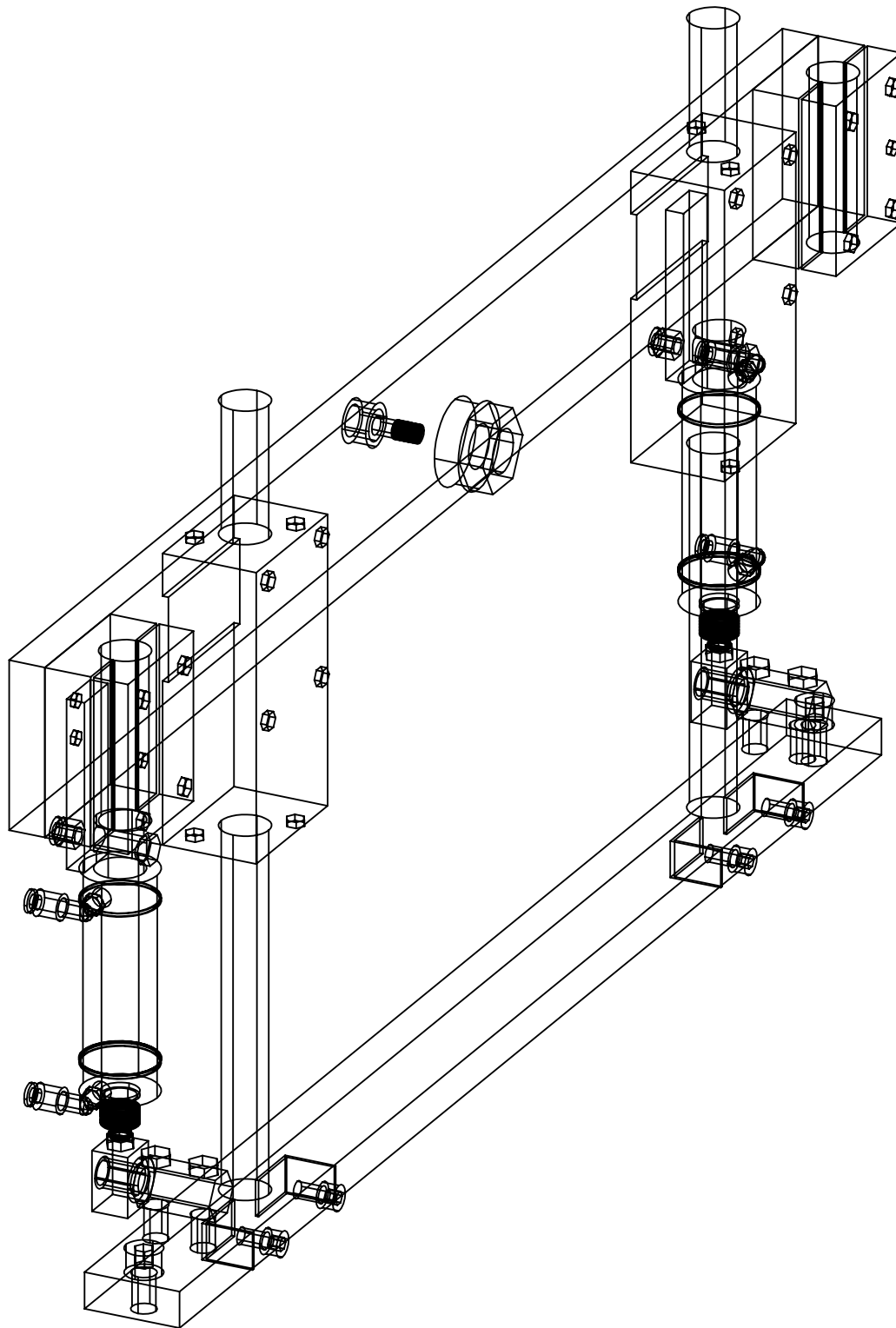

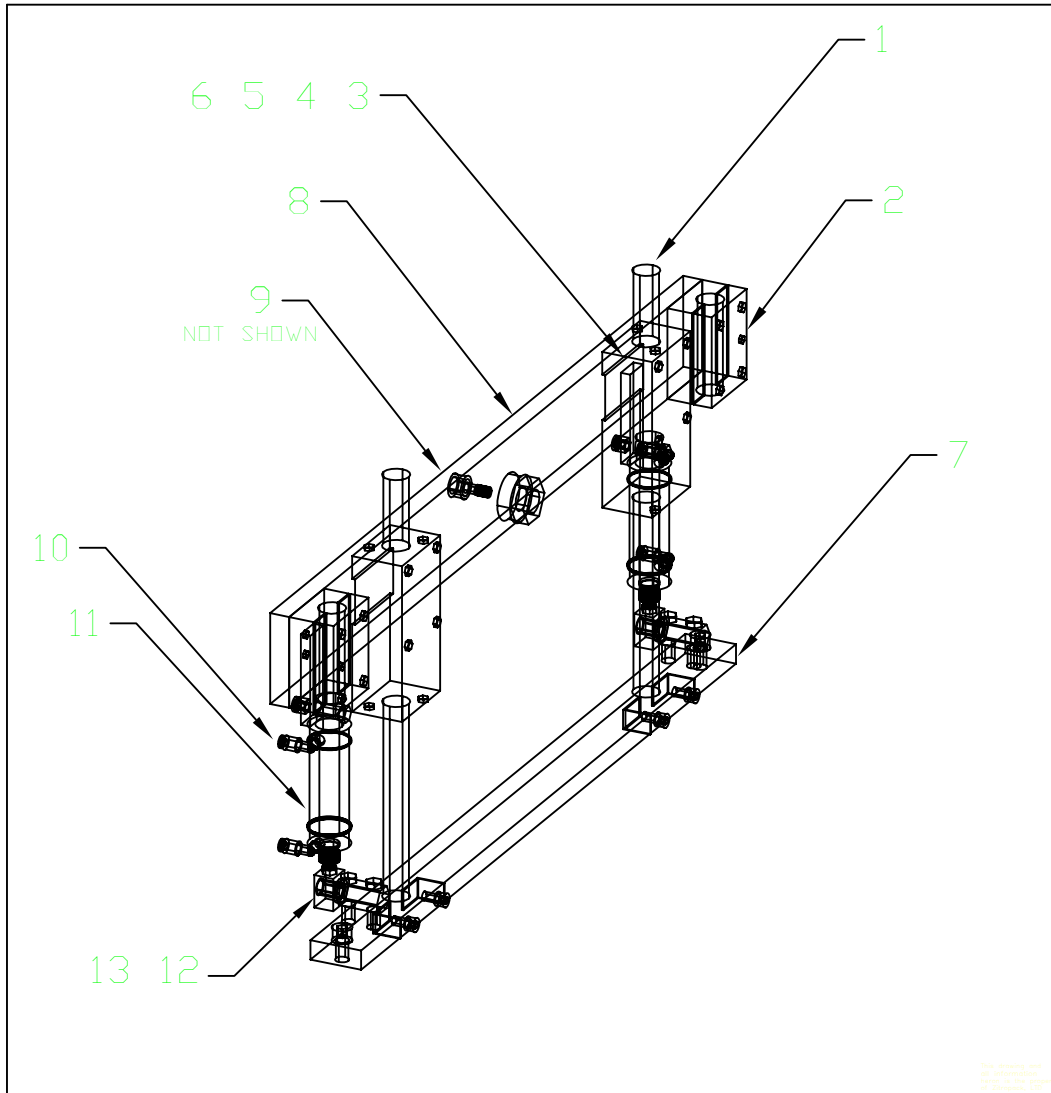

REVISIONS				
ZONE	REV	DESCRIPTION	DATE	APPROVED
	B	CAD ORIGINAL	03/23/00	

ITEM	PART NO	DESCRIPTION	REQ'D	M/P
1	1-16,250-S	THOMPSON ROD 16 1/4	2	M
2	XXXXXX	XXXXXXXXXXXXXXXXXXXXXXX	2	M
3	52801	THOMPSON BEARING BLOCK	2	M
4	B-162536	1" THOMPSON BALL BEARING	4	P
5	CR 9935	OIL SEAL 1 x 1 5/8 x 1/4	4	P
6	52802	BEARING SPACER	4	M
7	XXXXXX	XXXXXXXXXXXXXXXXXXXXXXX	1	M
8	82804	HEAT SEAL CROSS MEMBER	1	M
9	CFH-1 1/2-SB	HEAVY DUTY MODIFIED CAM FOLLOVER	1	P
10	XXXXXX	ELBOW CONNECTOR 1/4 x 1/4	4	P
11	SR-172-DP	ROUND AIR CYLINDER	2	P
12	53512	CONNECTING BLOCK	2	M
13	FB 810-7	FLANGED BUSHING 1/2 x 5/8 x 7/8	2	P

"M" MEANS MANUFACTURED & "P" MEANS PURCHASED

<h1>Z</h1>	Zitropack, Ltd.			
	TEL: 630-766-1015 FAX: 630-766-7211 E-MAIL: ZITROPACK@AOL.COM			
LOWER HEATER DRIVE				
MODEL: Z-4000 SERIAL# 2013	SIZE: B	NAME: R.O.	DWG NO.: 628001	REV: A
GENERAL MILLS-METHUEN, MA			SHEET	1 OF 1

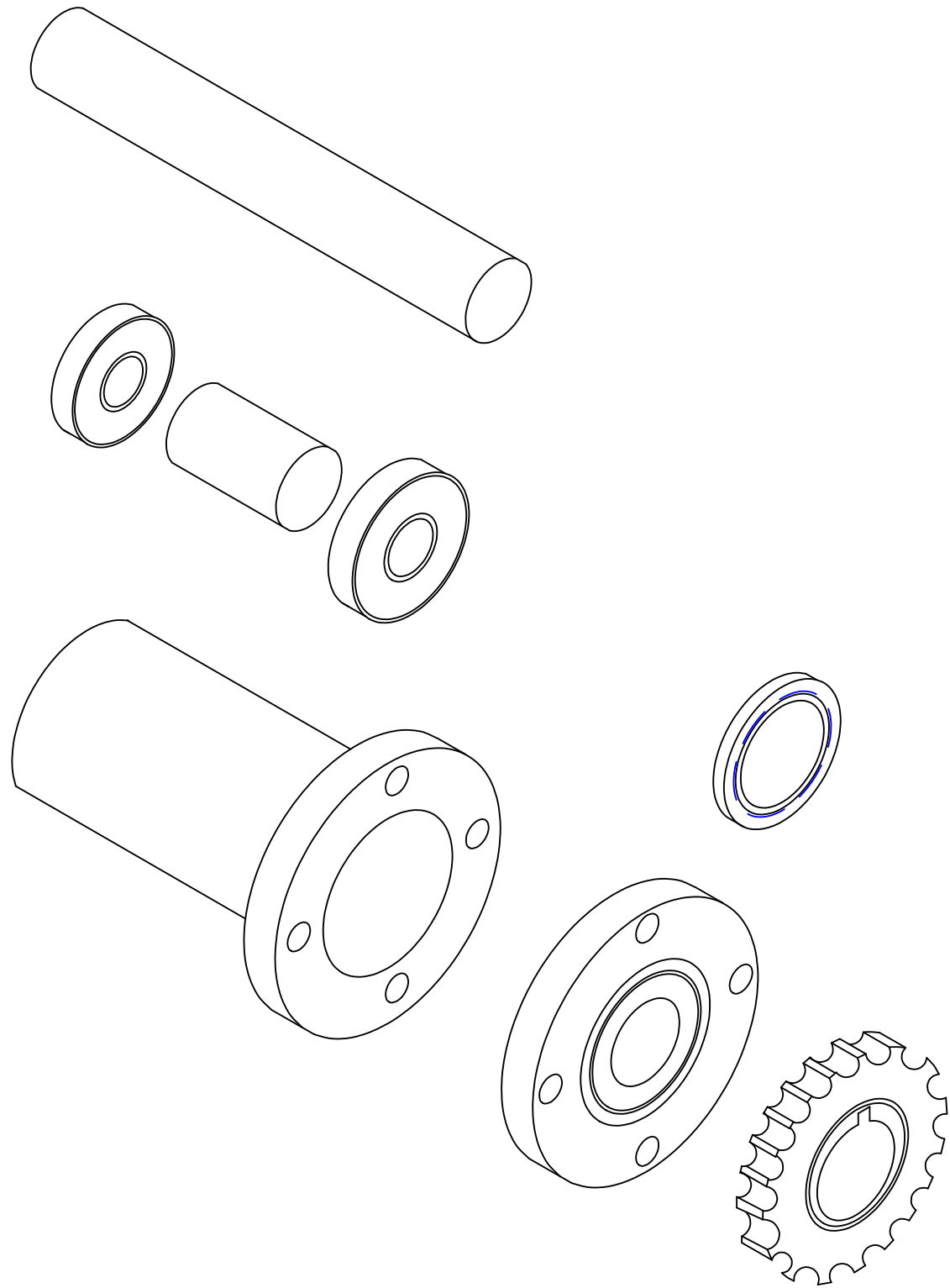

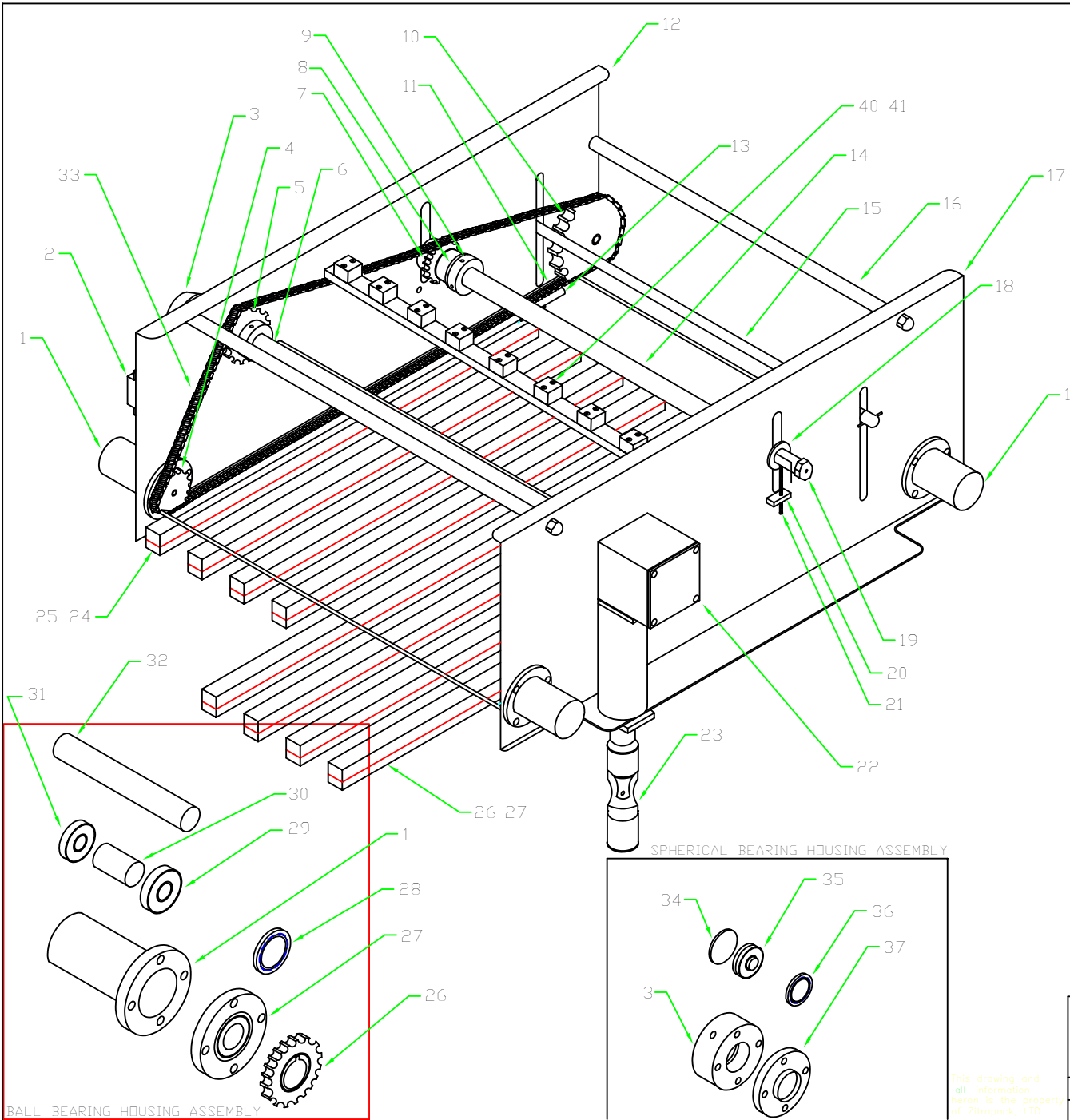

REVISIONS				
ZONE	REV	DESCRIPTION	DATE	APPROVED
x-y	A	CAD ORIGINAL	05/26/98	

ITEM	PART NUMBER	DESCRIPTION	REQD
1	BALL BEARING HOUSING	53620	4
2	SENSOR	115-6Y-06K	1
3	SPHERICAL BEARING HOUSING	53611	1
4	DISCHARGE IDLER SPROCKET	53624	2
5	DISCHARGE DRIVE SPROCKET	53607	2
6	DISCHARGE DRIVE SHAFT	53604	1
7	SPROCKET GEAR 51RS18	53653	2
8	DISCHARGE NYLON WASHER	53666	2
9	DISCHARGE TIGHTNER COLLAR	53623	2
10	DISCHARGE HEAD SPROCKET	53614	2
11	DISCHARGE SIDE BAR	53665	2
12	DISCHARGE FRAME RIGHT	53600	1
13	DISCHARGE CHAIN GUIDE	53664	2
14	DISCHARGE TIGHTNER SHAFT	53622	1
15	STOP CROSS ROD	53682	1
16	DISCHARGE FRAME ROD	53633	3
17	DISCHARGE FRAME LEFT	53601	1
18	DISCHARGE TIGHTNER WASHER	53620	1
19	DISCHARGE TIGHTNER NUT	53630	2
20	DISCHARGE TIGHTNER BLOCK	53631	2
21	DISCHARGE TIGHTNER SCREW	53632	1
22	GEAR BOX COVER	53603	1
23	UNIVERSAL JOINT D-10B	53652	1
24	DISCHARGE SLIDE MTD. BAR	83679-26.5	4
25	DISCHARGE SLIDE (PLASTIC)	83681-26.5	4
26	DISCHARGE SLIDE MTD. BAR	83679-31.75	4
27	DISCHARGE SLIDE (PLASTIC)	83682-31.75	4
28	DISCHARGE TAIL SPROCKET	53618	1
29	BALL BEARING CAP	53617	1
30	OIL SEAL 1 1/4 x 1 11/16 x 1/2	12336	1
31	BEARING 7874 x 2.0472 x .590	63042RS	1
32	HORIZONTAL BEARING SPACER	53616	1
33	BEARING 7874 x 1.8504 x .550	62042RS	1
34	BALL BEARING SHAFT	53615	1
35	CONNECTOR CHAIN UPPER	53642	2
36	O-RING 1 3/16 x 1 7/16 x 1/8	217	1
37	HEIM SSSL BEARING 3/4	LSS14	1
38	OIL SEAL 1 1/4 x 1 11/16 x 1/2	12336	1
39	SPHERICAL BEARING HOUSING CAP	53612	1
40	DISCHARGE PUSH BAR	83640	8
41	DISCHARGE SLIDE SPACER	83641	48

Z

**Zitropack, Ltd.**  
TEL: 630-765-7015 FAX: 630-765-7211 E-MAIL: ZITROPACK@AOL.COM

**DISCHARGE ASSEMBLY**

SIZE	NAME	REV. NO.	REV.
C	R.O.	Z-8000-2010	A
SERIAL # 2010		SCALE	HEET 1 OF 1

This drawing and all information herein is the property of Zitropack, Ltd.

REVISIONS				
ZONE	REV	DESCRIPTION	DATE	APPROVED
	B	CAD ORIGINAL	12/01/99	

ITEM	PART NUMBER	DESCRIPTION	REQD
1	NVFS2100-3F	SOLENOID VALVE	2
2	NVV5FS2-01T1-021-02T	SOLENOID VALVE	1
3	NVFS3100-3F	SOLENOID VALVE	1
4	NAR2000-N01	AIR REGULATOR	3
5	M100B-6EN	M 100 CLASSIC	1
6	FSD-311	AIR CYLINDER	6
7	SR-172 DP	AIR CYLINDER	2
8	K-10	AIR GAUGE	3
9	KQ2T07-00	UNION TEE	1
10	81191	AIR MANIFULL BLOCK	1

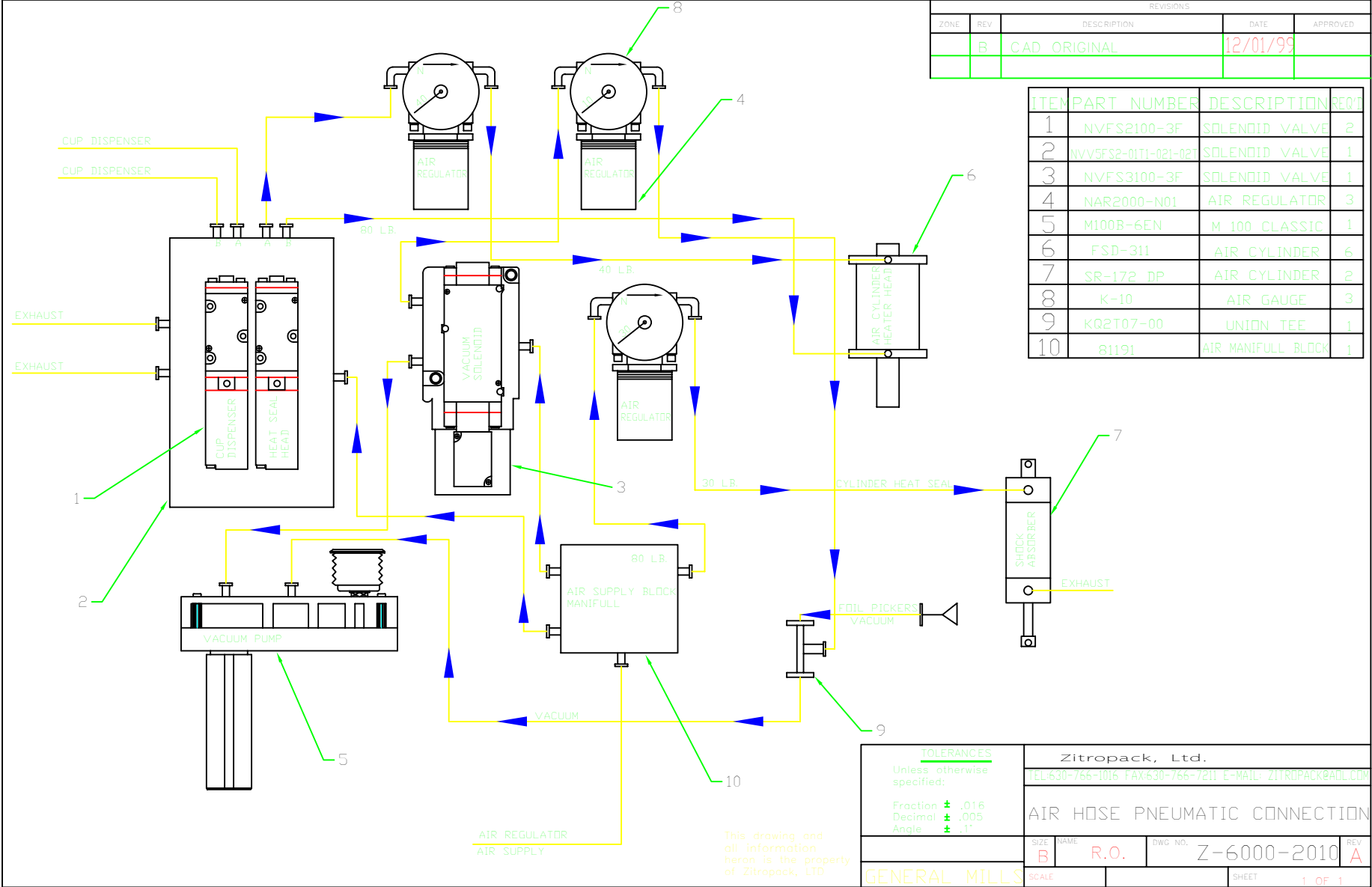

<b>TOLERANCES</b> Unless otherwise specified: Fraction $\pm .016$ Decimal $\pm .005$ Angle $\pm .1^\circ$		Zitropack, Ltd. TEL:630-766-1016 FAX:630-766-7211 E-MAIL: ZITROPACK@AOL.COM	
<b>AIR HOSE PNEUMATIC CONNECTION</b>			
SIZE	NAME	DWG NO.	REV
B	R.O.	Z-6000-2010	A
GENERAL MILLS		SHEET	1 OF 1







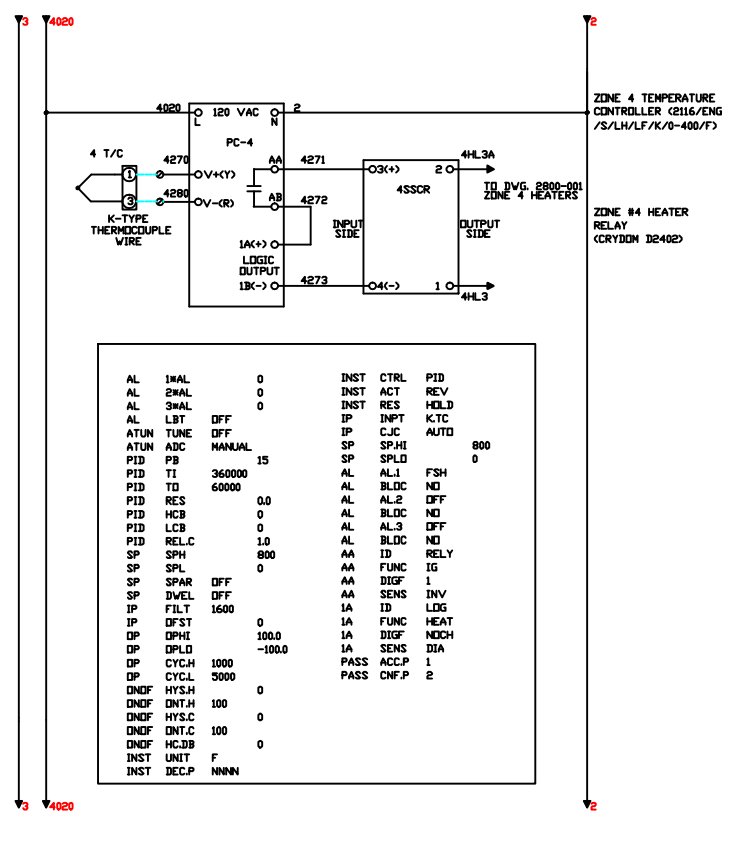
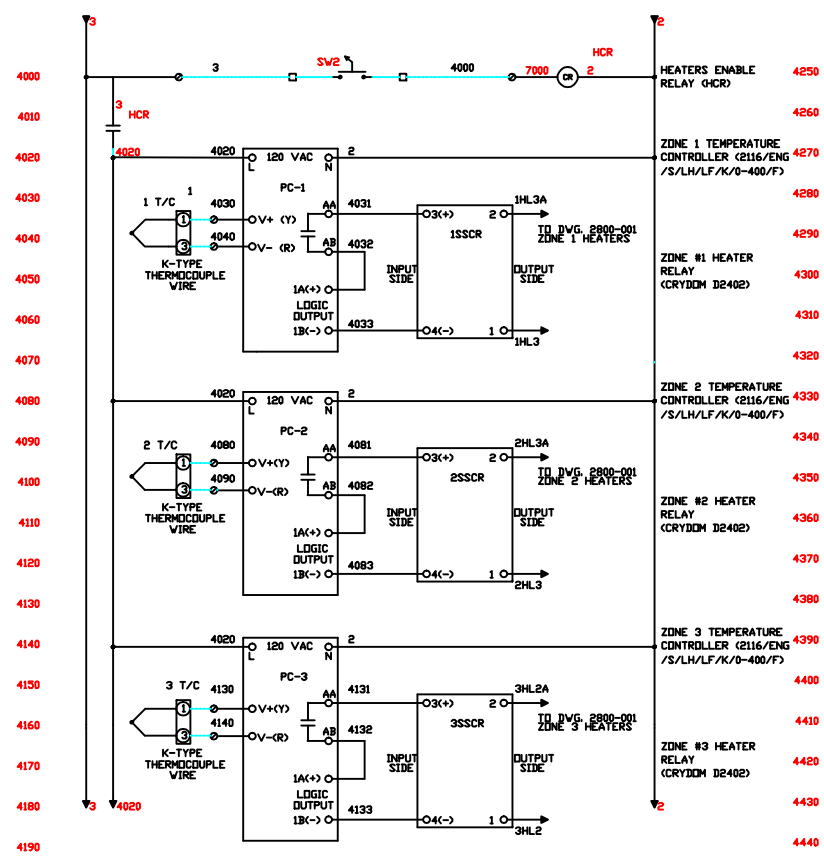

**NEW AGE**  
ELECTRICAL CONTROL, INC.

2800 N. 10TH STREET  
SUITE 100  
TULSA, OK 74104

TEMPERATURE CONTROL WIRING FOR  
22770PK GENERAL RELAY/PLC/RTU

NO	DATE	BY	REV	DATE	BY	REV
REV	DESCRIPTION	DATE	BY	REV	DATE	BY
REV	REVISION					

2800-004

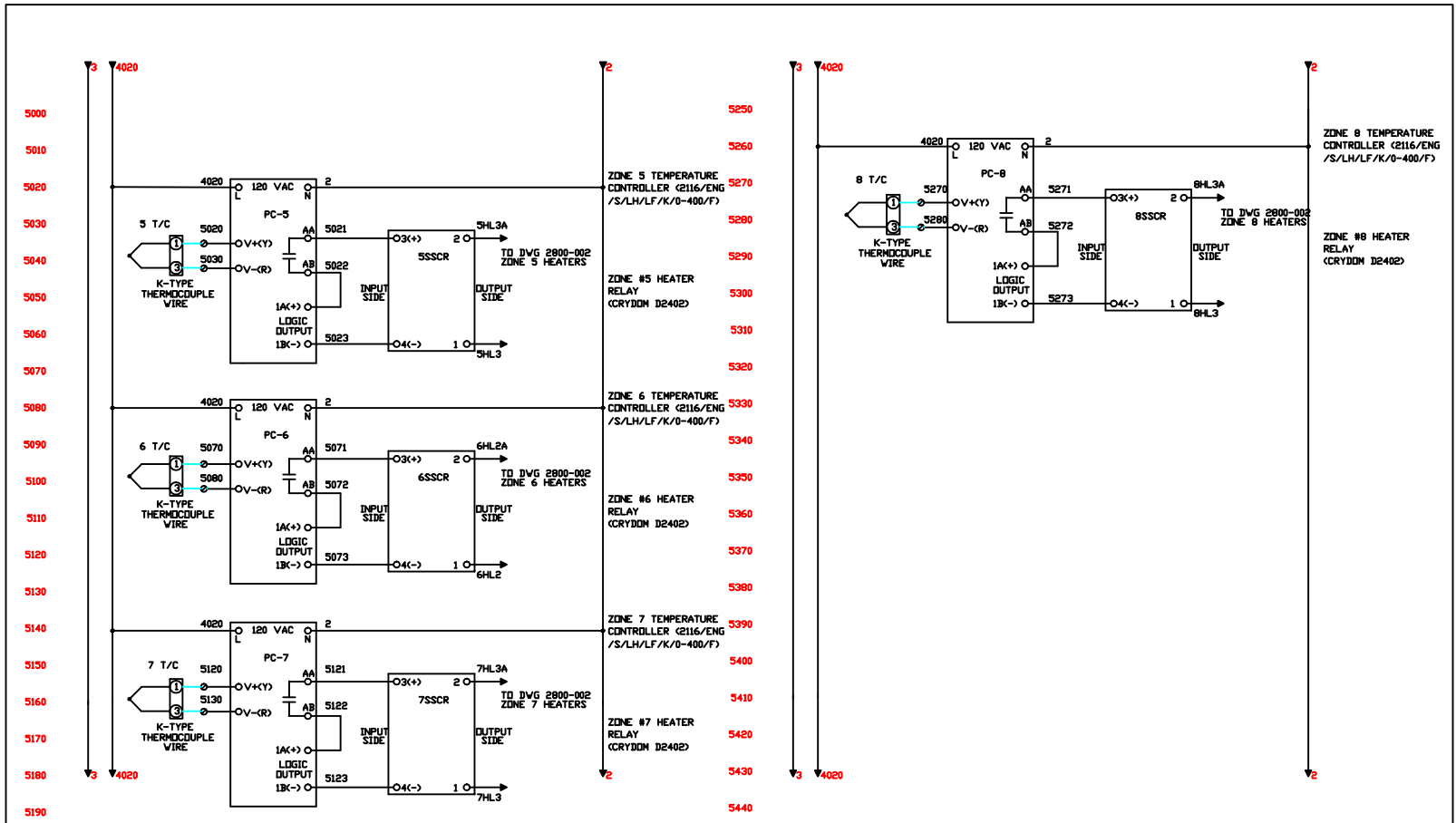

5000  
5010  
5020  
5030  
5040  
5050  
5060  
5070  
5080  
5090  
5100  
5110  
5120  
5130  
5140  
5150  
5160  
5170  
5180  
5190

5250  
5260  
5270  
5280  
5290  
5300  
5310  
5320  
5330  
5340  
5350  
5360  
5370  
5380  
5390  
5400  
5410  
5420  
5430  
5440

**NEW AGE**  
ELECTRICAL CONTROLS, INC.  
2800 N. 100TH STREET  
SUITE 100  
ZENON, MN 55089  
763-946-5000

TEMPERATURE CONTROL WIRING FOR  
Z1170PK (GENERAL BILLS/10/11/17)

REV:	AD BUILDS	7/1/99	DATE:	4/20/99	DATE:	4/20/99	ISSUE:	2800-005
NO:	DESCRIPTION	DATE	BY:	NO:	DATE	BY:	ISSUE:	
	REVISION			NONE		5 OF 5		

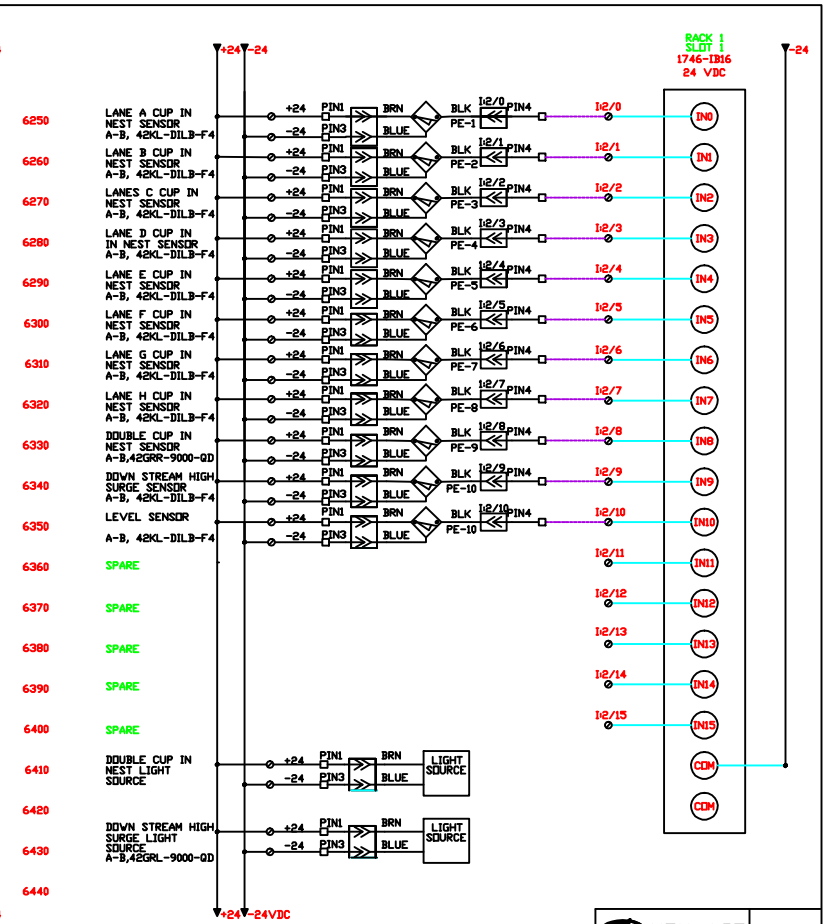
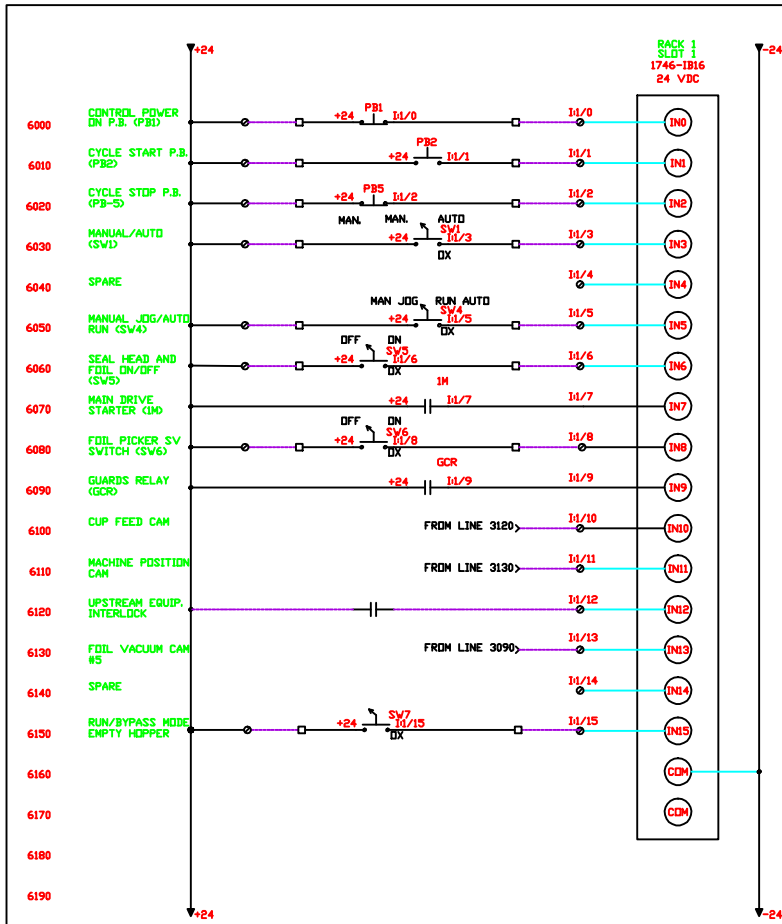

REV	DESCRIPTION	DATE	BY	CHKD	DATE	BY	NO	REV	DATE	BY
1	AS BUILT	7/1/99								
2		4/26/99								
3										
REVISION										

2800-006

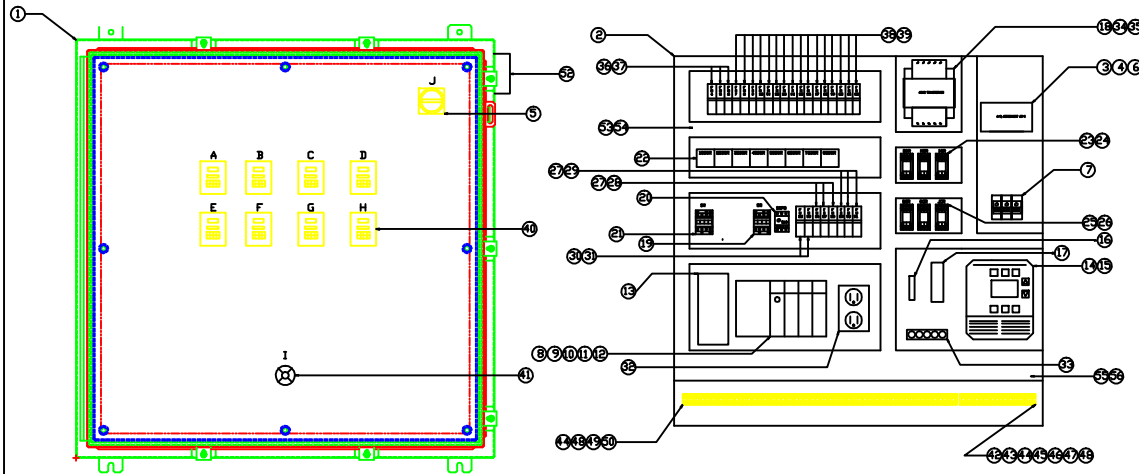

- 13111 1112 1113 1114 1115 1116 1117 1118 1119 1120 1121 1122 1123 1124 1125 1126 1127 1128 1129 1130 1131 1132
- 13211 1322 1323 1324 1325 1326 1327 1328 1329 1330 1331 1332 1333 1334 1335 1336 1337 1338 1339 1340 1341 1342
- 13511 1352 1353 1354 1355 1356 1357 1358 1359 1360 1361 1362 1363 1364 1365 1366 1367 1368 1369 1370 1371 1372
- 13811 1382 1383 1384 1385 1386 1387 1388 1389 1390 1391 1392 1393 1394 1395 1396 1397 1398 1399 1400 1401 1402
- 14111 1412 1413 1414 1415 1416 1417 1418 1419 1420 1421 1422 1423 1424 1425 1426 1427 1428 1429 1430 1431 1432
- 14411 1442 1443 1444 1445 1446 1447 1448 1449 1450 1451 1452 1453 1454 1455 1456 1457 1458 1459 1460 1461 1462
- 14711 1472 1473 1474 1475 1476 1477 1478 1479 1480 1481 1482 1483 1484 1485 1486 1487 1488 1489 1490 1491 1492
- 14911 1492 1493 1494 1495 1496 1497 1498 1499 1500 1501 1502 1503 1504 1505 1506 1507 1508 1509 1510 1511 1512
- 15111 1512 1513 1514 1515 1516 1517 1518 1519 1520 1521 1522 1523 1524 1525 1526 1527 1528 1529 1530 1531 1532
- 15311 1532 1533 1534 1535 1536 1537 1538 1539 1540 1541 1542 1543 1544 1545 1546 1547 1548 1549 1550 1551 1552

LEGEND SCHEDULE	
A	ZONE A TEMP. CNT
B	ZONE B TEMP. CNT
C	ZONE C TEMP. CNT
D	ZONE D TEMP. CNT
E	ZONE E TEMP. CNT
F	ZONE F TEMP. CNT
G	ZONE G TEMP. CNT
H	ZONE H TEMP. CNT
I	EMERGENCY STOP
J	460V 3PH 60HZ

BILL OF MATERIALS	
ITEM QTY	DESCRIPTION
1	HOFFMAN, A-360612SSLP, ENCLOSURE STAINLESS MENA 4X, 36"x36"x12"
2	HOFFMAN, A-36P36, SUB PANEL 36" x 36"
3	ALLEN BRADLEY, 194R-4LOGP3, DISCONNECT FUSED 60 AMPS.
4	ALLEN BRADLEY #194R-R2 SHAFT
5	ALLEN BRADLEY #194R-HS4 HANDLE MENA 4X
6	BUSSMAN, LPJ-405P, FUSES TIME DELAY RATED 40 AMPS.
7	ALLEN-BRADLEY, 1492-SMG141, POWER DISTRIBUTION BLOCK 1 TO 4
8	ALLEN-BRADLEY, 1747-1542, SLC 5/D4 PROCESSOR.
9	ALLEN-BRADLEY, 1746-M, 4 SLOT SLC CHASSIS.
10	ALLEN-BRADLEY, 1746-P1, SLC POWER SUPPLY.
11	ALLEN-BRADLEY, 1746-1B16, 10-30 VDC SINK INPUT CARD, 16 POINTS.
12	ALLEN-BRADLEY, 1746-DB16, 110 VAC OUTPUT CARD, 16 POINT.
13	STLA, SLS-04-006, 24 VDC TOWER SUPPLY AT 3.6 AMPS.
14	ALLEN-BRADLEY, 1305-3A09A, INVERTER RATED FOR 5 H.P. AT 460 VAC.
15	ALLEN-BRADLEY, 1201-HMP, PROGRAMMER KEYPAD FOR ABOVE INVERTER.
16	SUPERIOR, A201053G10, CAPACITOR 6.5 UF AT 330 VOLTS.
17	SUPERIOR, A201052G13, POWER RESISTOR 150 OHMS AND 30 WATTS.
18	ACME, TAC-91215-F3, 300 VA TRANS. 480/460/440 PRIM 120/115/110 SEC
19	ALLEN-BRADLEY, 100-C0910, MCS CONTACTOR RATED 5 H.P. AT 460.
20	ALLEN-BRADLEY, 140-M-0160, MAIN MOTOR PROTECTOR 1 TO 1.6 AMPS.
21	ALLEN-BRADLEY, 100-C2310, MCS CONTACTOR RATED 15 H.P. AT 460 V.
22	CRYDOM, 27F3B0, POWER RELAY 12 AMP AT 240VAC, DC CONTROL.
23	ALLEN-BRADLEY, 700-H432A1-1-4, RELAY WITH MAIN OPER. AND LIGHT.
24	ALLEN-BRADLEY, 700-H412S, 8 PIN TUBE BASED SOCKET.
25	ALLEN-BRADLEY, 700-H403A1-1-4, SIGNAL GRADE RELAY 3PDT.
26	ALLEN-BRADLEY, 700-H412S, SOCKET 11 PIN TUBULAR.
27	SQUARE D, 9080-GF6, FUSE BLOCK RATED 30 AMPS AT 600 VAC.
28	BUSSMAN, FMO-8, TIME DELAY FUSE 13/32" x 1-1/2" 500VAC, 8 AMPS.
29	BUSSMAN, FMO-15, TIME DELAY FUSE 13/32" x 1-1/2" 500VAC, 15 AMPS.
30	BUSSMAN, GNC10, TIME DELAY FUSE, .197" x .788" 10 AMPS @ 125V.
31	ALLEN-BRADLEY, 1492-WF34, FUSE BLOCK RATED 300V
32	OUTLET BOX
33	1/2" DIA. #6-32-12, GROUND BAR.
34	BUSSMAN, FMO-3, TIME DELAY FUSE, 500VAC 3 AMPS
35	BUSSMAN, FMO-R-6, CLASS CC TIME DELAY FUSE, 600V 6 AMPS.
36	BUSSMAN, TIME DELAY FUSE CLASS CC 600V 6 AMPS.
37	BUSSMAN, BC6033P, 3 POLE CLASS CC FUSE BLOCK 600V 30 AMPS.
38	BUSSMAN, LP02-1-1/2", TIME DELAY FUSE CLASS CC 600V 30 AMPS.
39	BUSSMAN, BC6031P, FUSE BLOCK CLASS CC 600V 30 AMPS 1 POLE.
40	EUROTHERM, 2711-ENG-LH-FH-K-32-800-F-XV, PROCESS CONTROLLER.
41	ALLEN-BRADLEY, 600H-FRXP16RA1, 2 POSITION ILLUMINATED E-STOP.
42	ALLEN-BRADLEY, 1492-WT33, 3 TIER TERMINAL BLOCKS.
43	ALLEN-BRADLEY, 1492-ERT33, 3 TIER TERMINAL BLOCK END BARRIER.
44	ALLEN-BRADLEY, 1492-EA3S, 35MM END BARRIER.
45	ALLEN-BRADLEY, 1492-SJ15-20-R, 20 POLE CONTINUOUS RED JUMPER.
46	ALLEN-BRADLEY, 1492-SJ15-20-B, 20 POLE CONTINUOUS JUMPER RED.
47	ALLEN-BRADLEY, 1492-SMG24, MARKING SYSTEM FOR THREE TIER TERMINAL.
48	ALLEN-BRADLEY, 1492-DR6, HIGH RISE 35MM CHANNEL.
49	ALLEN-BRADLEY, 1492-V4, 100 TERMINAL BLOCKS.
50	ALLEN-BRADLEY, 1492-SMG12, MARKING SYSTEM FOR 1492-V4 TERMINALS.
51	BUSSMAN, BC6031P, FUSE BLOCK CLASS CC 600V 30 AMPS 1 POLE.
52	FERRAL SIGNAL, 550-120-30, ALARM HORN.
53	LOT PANDUIT, E3 x 1/4", PANDUIT WIRING DUCT 3" TALL BY 1" WIDE.
54	LOT PANDUIT, C1W6, DUCT COVER 1" WIDE.
55	LOT PANDUIT, E3 x 3/8", WIRING DUCT 3" TALL BY 3" WIDE.
56	LOT PANDUIT, C3W6, DUCT COVER 3" WIDE.



5405 WEST 100TH PLACE  
 SUITE 111  
 OVERLAND PARK, MO 66210  
 (816) 875-9999

CONTROL PANEL LAYOUT FOR  
 ZITROPHACK GENERAL BUILD

DATE: 4/15/99  
 DRAWN: [blank]  
 CHECKED: [blank]  
 REVISION: 5 OF 9

NO.	DESCRIPTION	DATE BY	REV.	DATE	BY	REVISION

2800-009