

## MTH PUMPS

# M50 • L50 Series Multistage Regenerative Turbine Pumps

- Capacities to 40 GPM
- Heads to 2300 Feet
- Single or Multi-stage Units (up to 5 stages)
- Vertical Close Coupled
- Horizontal Close Coupled
- Horizontal Flexible Coupled



Vertical base mount and horizontal pedestal mounted multi-stage regenerative turbine pumps represent the most economical high performance alternative for low flow (2 to 38 GPM) applications involving moderate to high pressures (heads to 2300 feet).

By combining the latest concepts in hydraulic turbine pump design with precision computer controlled manufacturing, M50 Series pumps deliver high efficiency operation even at low NPSH. Costs are controlled by efficient manufacturing processes, use of standard motors, and highly optimized pump designs. Maintenance costs are kept to a minimum by combining an easily serviceable design with the use of high quality components to provide long life.

### Water Passage Design

MTH masters one of the most critical design considerations of regenerative turbine pumps - the shaping of water passageways to achieve maximum capacity and pressure while minimizing horsepower requirements. By optimizing water

passageway cross-sectional profiles for each impeller, MTH improves both efficiency and pressure in the M50 Series, and exceeds the standards realized by previous techniques.

### Impeller Profile

One of the most notable improvements in regenerative turbine pump technology, incorporated in M50 Series pumps, involves the ability to determine the optimum impeller width and blade length. These factors have a significant effect on the required horsepower versus pressure curve for regenerative turbine pumps. By optimizing these for each pump, peak efficiency is improved and "off peak" horsepower requirements are reduced as well.

### Impeller Blades

After the most favorable impeller profile has been determined for a particular water passageway cross-section, MTH calculates the number of blades needed to maximize the performance of that pump. The blade design in M50 Series pumps increases both efficiency and design pressure without incurring the manufacturing difficulties associated

with producing contoured blade impellers. State-of-the-art computer controlled machines simplify manufacturing of the various MTH impellers utilized in the M50 Series. The result is a high performance pump providing efficiency characteristics exceeding those of much more expensive units.

### NPSH Requirements

M50 Series regenerative turbine pumps meet low net positive suction head (NPSH) requirements without efficiency loss. This is achieved by keeping the inlet fluid velocity low and then gently accelerating to passageway velocities. Special ramps are responsible for this gentle fluid entry into the impeller blades and account for the high inlet efficiency of the M50 Series pumps.

### Low NPSH Requirements



## MTH PUMPS

401 West Main Street • Plano, IL 60545-1436  
Phone: 630-552-4115 • Fax: 630-552-3688  
Email: SALES@MTHPUMPS.COM  
<http://WWW.MTHPUMPS.COM>

## MTH PUMPS

# M50 • L50 Series Multistage Regenerative Turbine Pumps

L50 Series regenerative turbine pumps have exceptionally low NPSH requirements, making them ideally suited for applications where very little inlet head is available.

This reduced NPSHR provided by the

L50 Series is obtained by using a first stage centrifugal style impeller with inlet flow paths shaped to maintain a constant fluid velocity. This reduces entry losses to the impeller as well as maintaining efficiency. A multi-vane diffuser is used in conjunction with the centrifugal impeller for

balancing radial loads and extracting the maximum pressure from the first stage. Pressure and flow produced by the NPSH inducer assures that the succeeding stages are adequately fed.

## STANDARD MATERIALS

PART	BRONZE FITTED	ALL IRON	ALL BRONZE	STAINLESS STEEL
Inlet Cover	Cast Iron ASTM A48	Cast Iron ASTM A48	Bronze ASTM B62	Stainless Steel
Outlet Cover	Cast Iron ASTM A48	Cast Iron ASTM A48	Bronze ASTM B62	Stainless Steel
Impeller	Bronze ASTM B62	Carbon Steel 12L14	Bronze ASTM B62	Stainless
Shaft	Stainless Steel AISI 416	Stainless Steel AISI 416	Stainless Steel AISI 316	Stainless Steel
"O" Rings	Buna N	Buna N	Buna N	Viton
Seals	Buna/Ceramic	Buna/Ni-Resist	Buna/Ceramic	Viton/Ceramic

## LIMITATIONS

Discharge Pressure	1000 PSI
Seal Pressure*	200 PSI
Suction Pressure (Min.)	26" Hg Vac.
Speed	3600 RPM

### Temperature

Standard Construction	-20°F
Ceramic Seal Seat - Water	230°F
Silicon Carbide Seal Seat & External Seal Flush	250°F

### Horsepower

C3 - P3	1/3 to 3 HP
C30 - P30	5 to 30 HP

\*Suction Pressure Plus a Percentage of Differential Pressure

## Engineering Specifications

### M50 • L50 SERIES

The contractor shall furnish (and install as shown on the plans) an MTH (M50) (L50) Series (horizontal) (vertical base mount) close coupled (horizontal pedestal mounted) regenerative turbine type pump model \_\_\_\_ size \_\_\_\_ of (BRONZE FITTED) (ALL IRON) (ALL BRONZE) (316 STAINLESS STEEL) construction. Each pump shall have a capacity of \_\_\_\_GPM when operating at a total head of \_\_\_\_feet. Suction pressure will be \_\_\_\_feet with a liquid temperature of \_\_\_\_degrees F.

The pump is to be furnished with a mechanical seal with stainless steel metal parts, (Buna) (EPR) (Teflon) (Viton) elastomers, (ceramic) (ni-resist) (silicon carbide) (tungsten carbide) seat and carbon washer. Pump will have shaft sleeve or stainless steel shaft which will prevent pumped fluid from contacting motor shaft.

The L50 Series pump shall be low NPSHR inducer style design with a centrifugal radial vane design impeller and a multi-vane diffuser for balancing radial loads. The pump shall be vertically split

design with replaceable external channel rings that have water passageways accurately machined into each ring. The suction and discharge will have (NPT) (SAE) (BSP) (ISO) threads located in the top vertical position for self-venting and shall be cast separately from one another. The impeller(s) shall be hydraulically self-centering and no external adjustment shall be necessary.

The close coupled pump shall be mounted to a standard NEMA \_\_HP \_\_phase \_\_Hertz \_\_volt \_\_RPM (horizontal) (vertical), (open drip proof) (totally enclosed) (explosion proof) motor. Each pump shall be tested at the specified capacity and head prior to shipment. The motor shall be sized to prevent overloading at the highest head condition listed in the specifications.

The pedestal mounted pump shall be mounted on a bearing pedestal with sealed, grease lubricated ball bearings having a two year minimum design life under a maximum pump differential pressure of 1000 PSI, and the shaft shall be of a stainless steel material. Pump and motor shall be mounted on a com-

mon steel baseplate, flexible coupled with coupling guard to a standard horizontal NEMA \_\_HP \_\_phase \_\_Hertz \_\_volt \_\_RPM (open drip proof) (totally enclosed) (explosion proof) motor. Coupling alignment shall be checked after installation. Each pump shall be tested at the specified capacity and head prior to shipment. The motor shall be sized to prevent overloading at the highest head condition listed in the specifications.



## MTH PUMPS

401 West Main Street • Plano, IL 60545-1436  
Phone: 630-552-4115 • Fax: 630-552-3688  
Email: SALES@MTHPUMPS.COM  
http://WWW.MTHPUMPS.COM

M50 • L50 SERIES

# Performance Curves

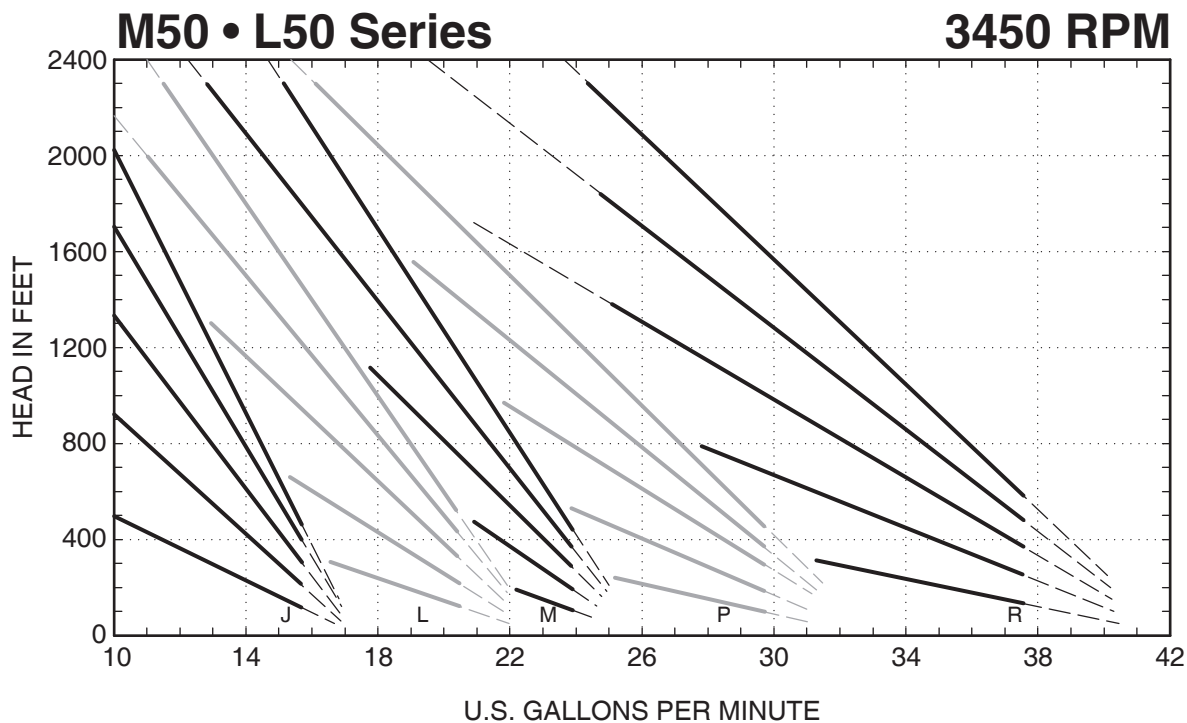
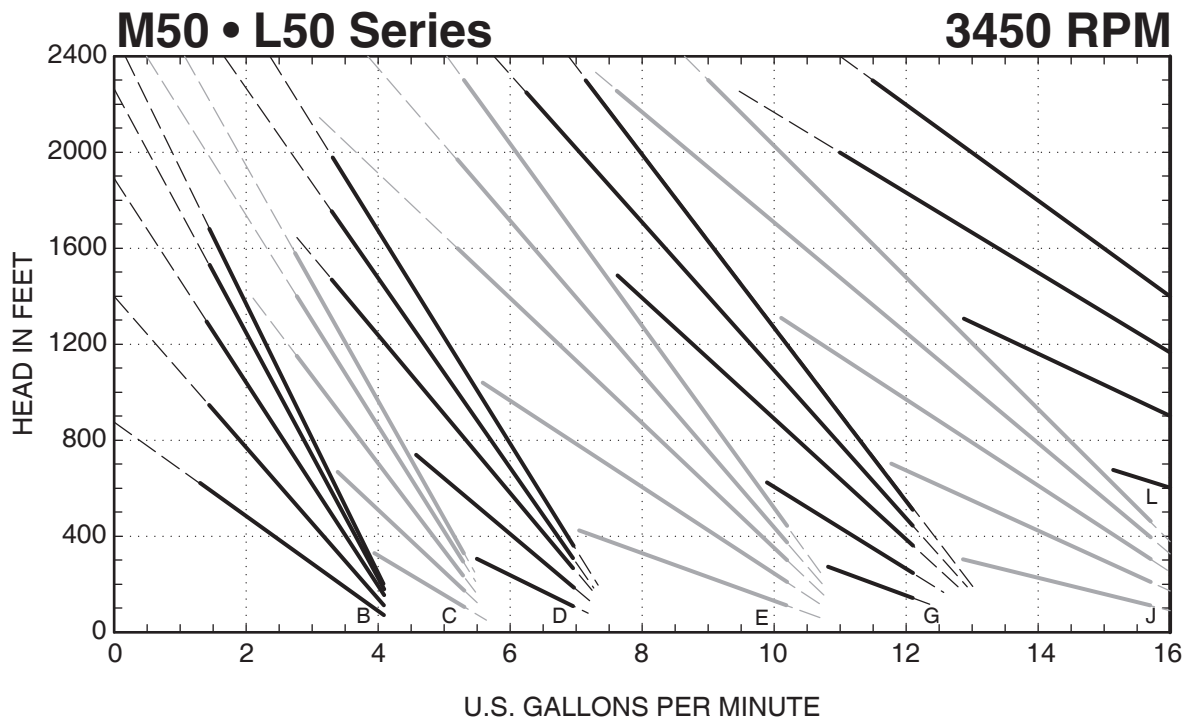

**NOTES**

- Usable Operating Range
- - - Refer to Factory for Operation in this Range
- Refer to Individual Curves for Horsepower and NPSH Requirements

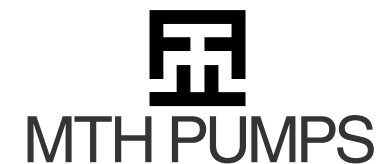

401 West Main Street • Plano, IL 60545-1436  
 Phone: 630-552-4115 • Fax: 630-552-3688  
 Email: SALES@MTHPUMPS.COM  
 http://WWW.MTHPUMPS.COM

M50 • L50 SERIES PUMPS

M50 • L50 SERIES

# Performance Curves

M50 • L50 SERIES PUMPS

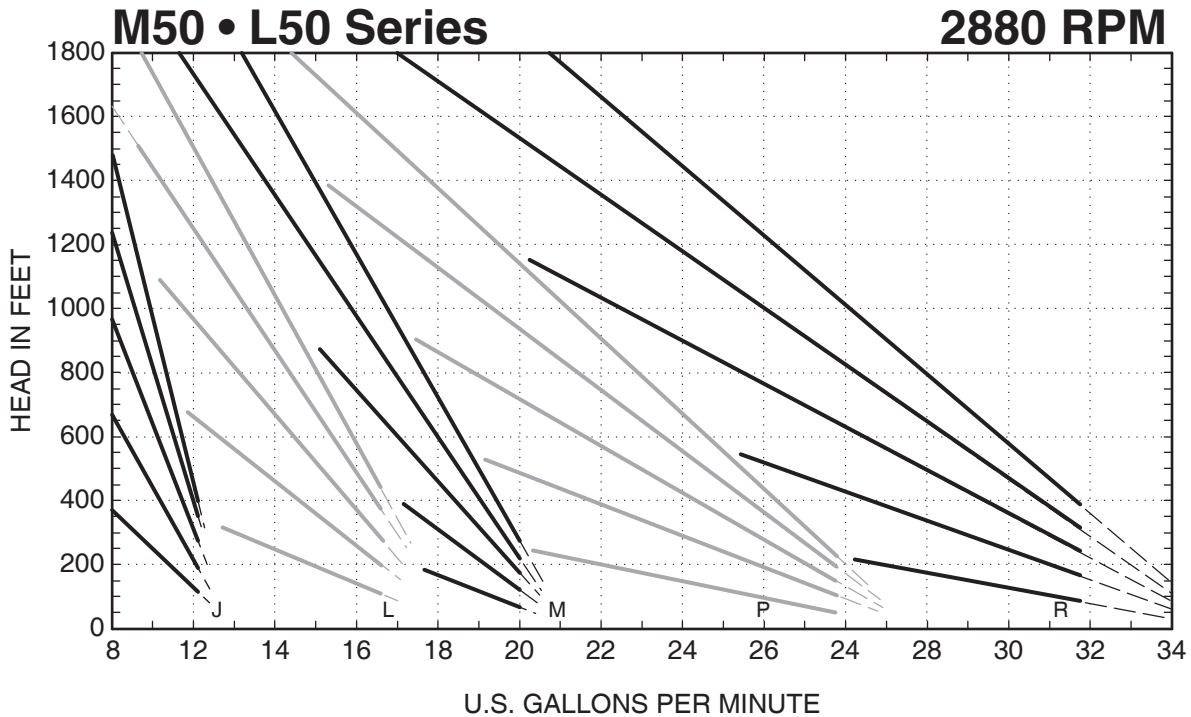
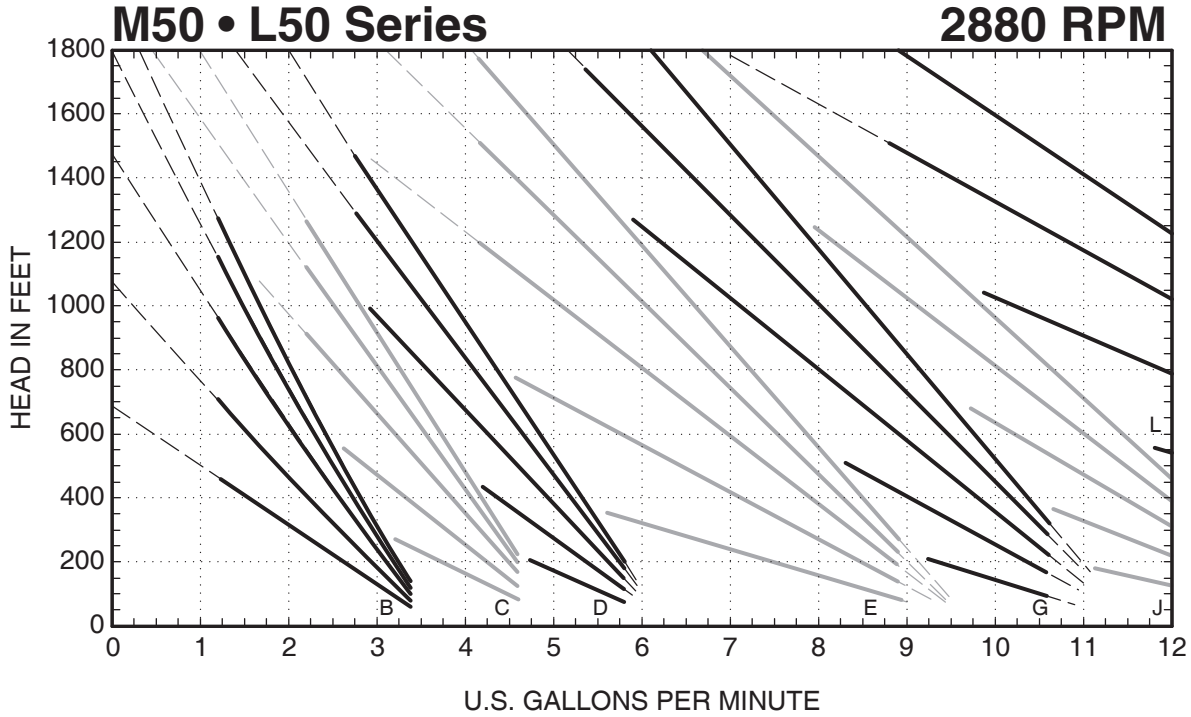

**NOTES**

- Usable Operating Range
  - - - Refer to Factory for Operation in this Range
- Refer to Individual Curves for Horsepower and NPSH Requirements



401 West Main Street • Plano, IL 60545-1436  
 Phone: 630-552-4115 • Fax: 630-552-3688  
 Email: SALES@MTHPUMPS.COM  
<http://WWW.MTHPUMPS.COM>

M50 • L50 SERIES

# Performance Curves

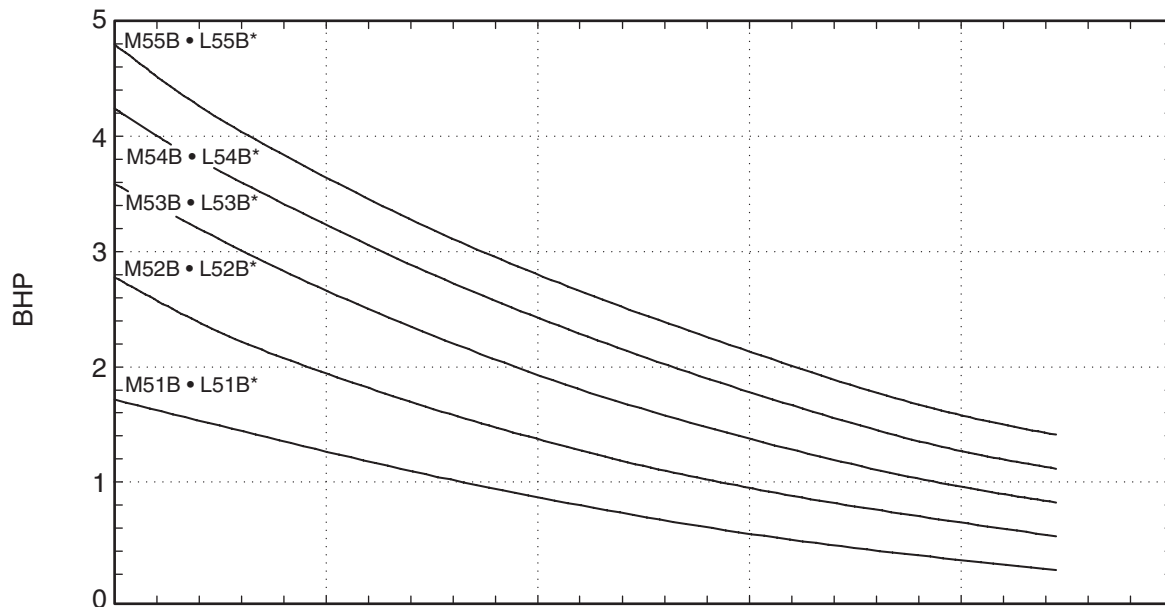
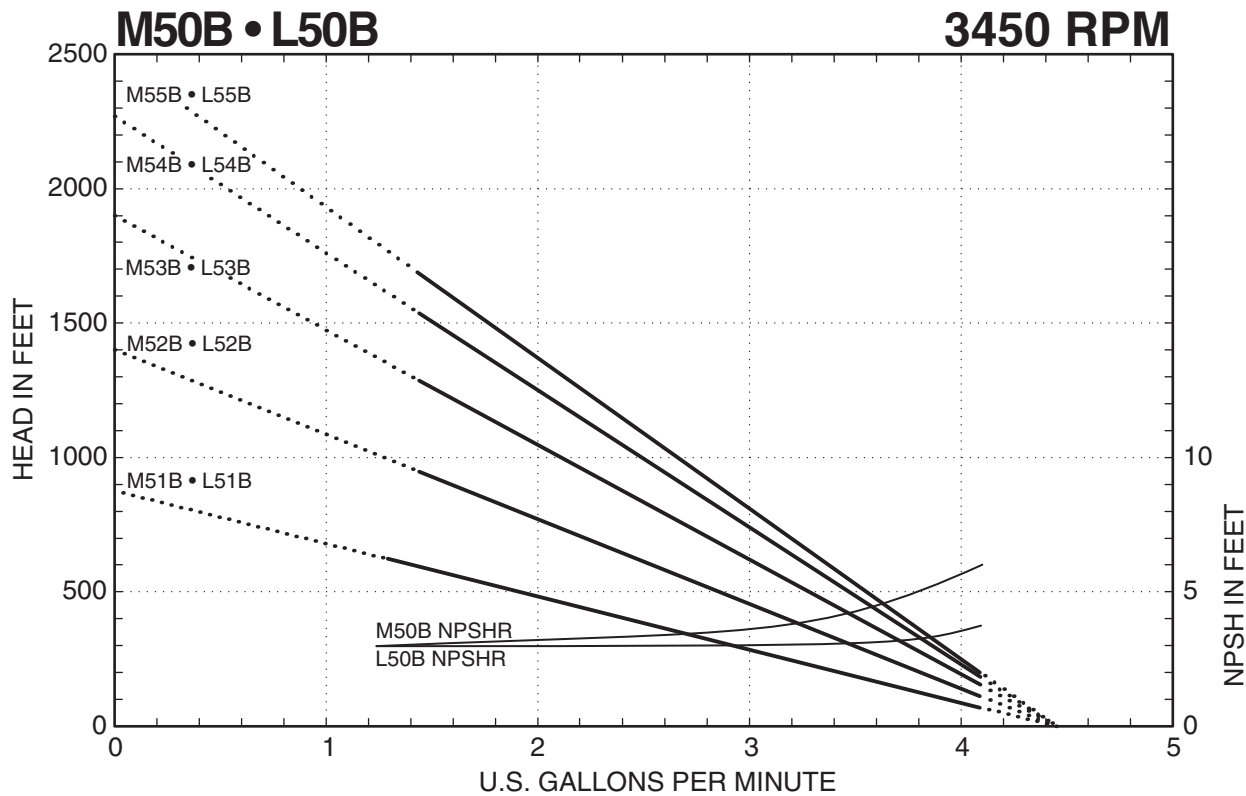

**NOTES**

- Recommended Operating Range
- ..... Refer to Factory for Operation in this Range
- \*Add .43 horsepower for L50B Inducer Models
- Horsepower data is valid for 1.0 specific gravity fluids only



401 West Main Street • Plano, IL 60545-1436  
 Phone: 630-552-4115 • Fax: 630-552-3688  
 Email: SALES@MTHPUMPS.COM  
 http://WWW.MTHPUMPS.COM

M50 • L50 SERIES PUMPS

# Performance Curves

M50 • L50 SERIES PUMPS

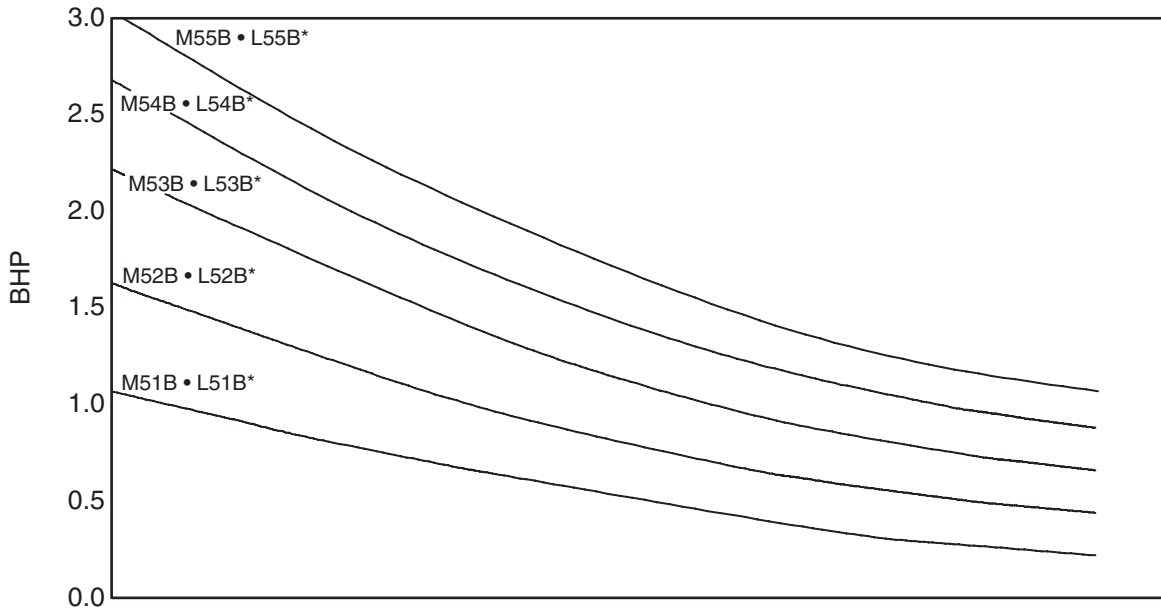
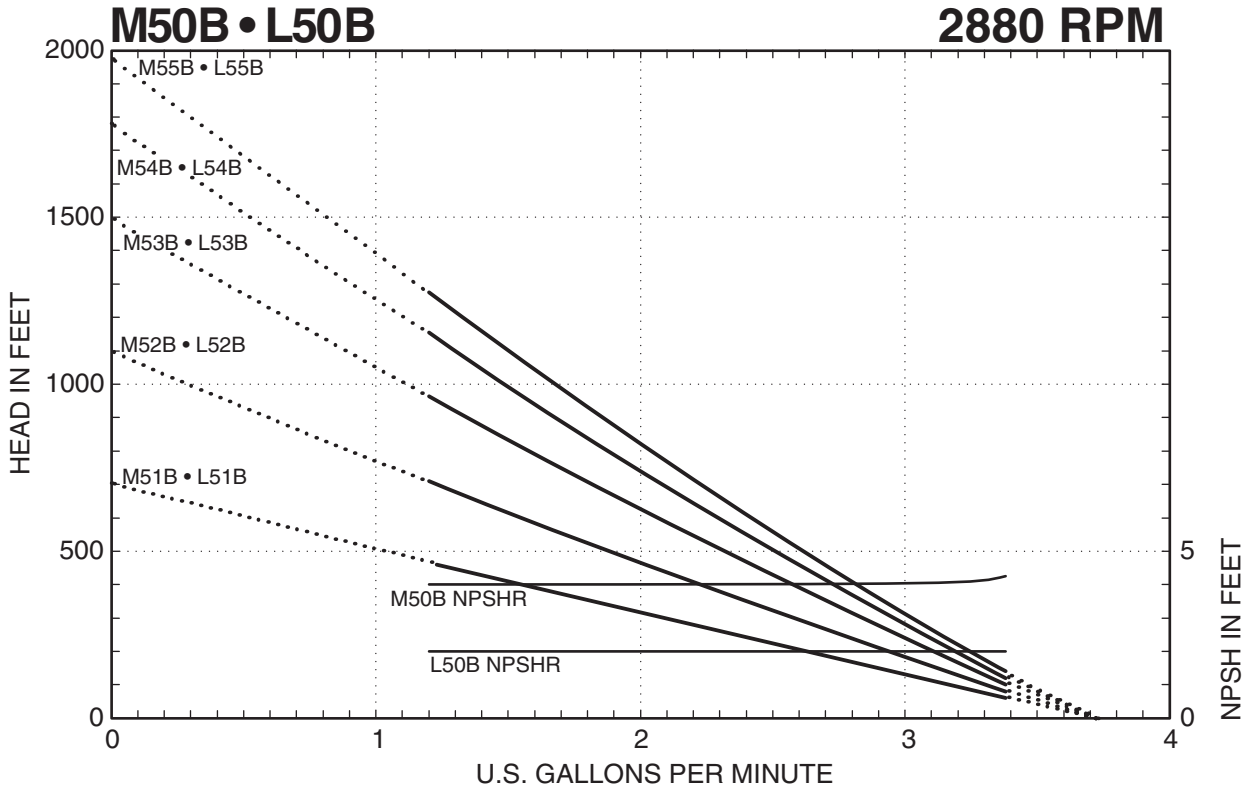

**NOTES**

- Recommended Operating Range
- ..... Refer to Factory for Operation in this Range
- \*Add .26 horsepower for L50B Inducer Models
- Horsepower data is valid for 1.0 specific gravity fluids only



**MTH PUMPS**

401 West Main Street • Plano, IL 60545-1436  
 Phone: 630-552-4115 • Fax: 630-552-3688  
 Email: SALES@MTHPUMPS.COM  
 http://WWW.MTHPUMPS.COM

M50 • L50 SERIES

# Performance Curves

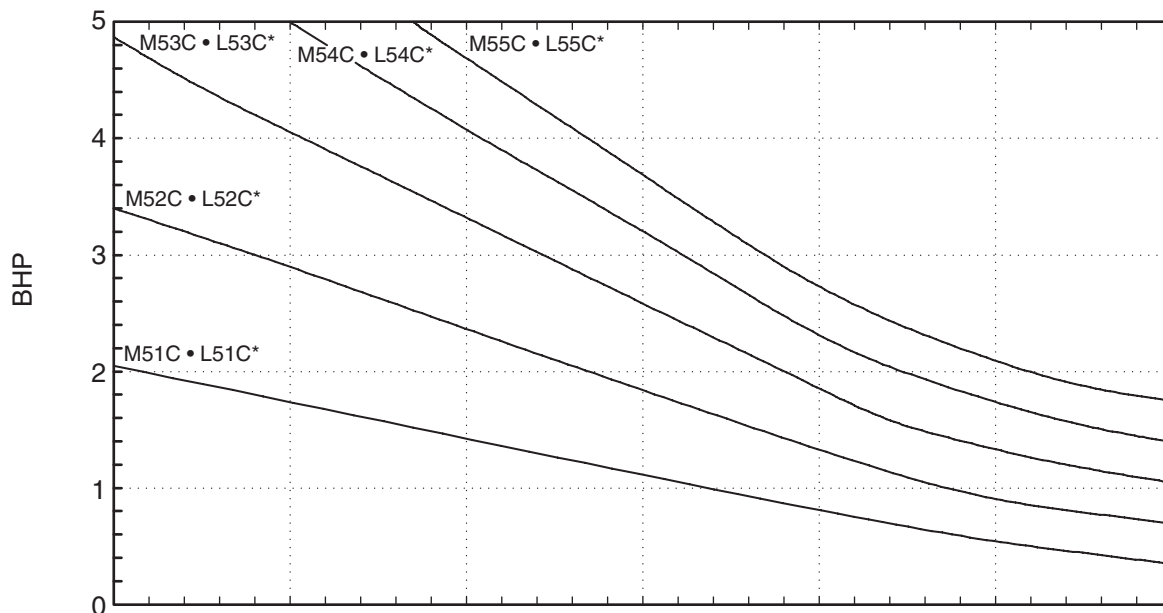
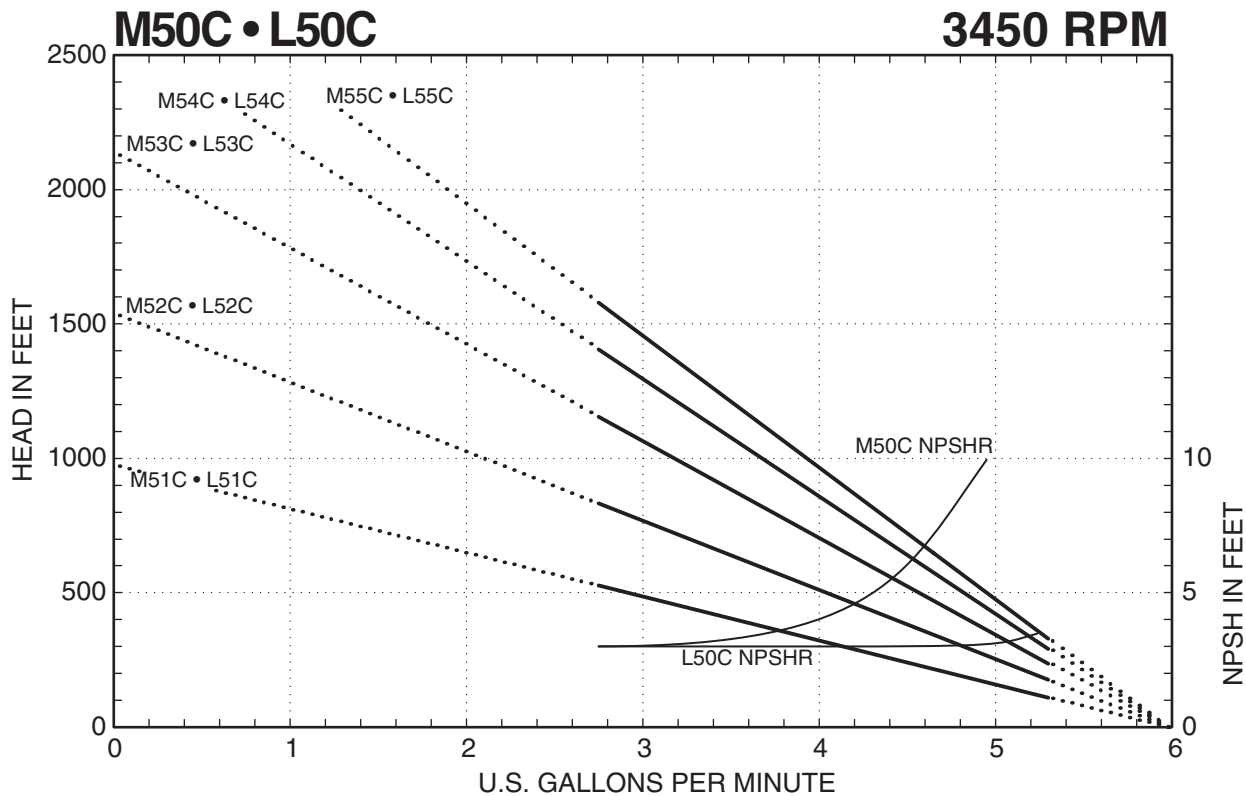

**NOTES**

— Recommended Operating Range  
 ..... Refer to Factory for Operation in this Range  
 \*Add .45 horsepower for L50C Inducer Models  
 Horsepower data is valid for 1.0 specific gravity fluids only



**MTH PUMPS**

401 West Main Street • Plano, IL 60545-1436  
 Phone: 630-552-4115 • Fax: 630-552-3688  
 Email: SALES@MTHPUMPS.COM  
 http://WWW.MTHPUMPS.COM

M50 • L50 SERIES PUMPS



M50 • L50 SERIES

# Performance Curves

M50 • L50 SERIES PUMPS

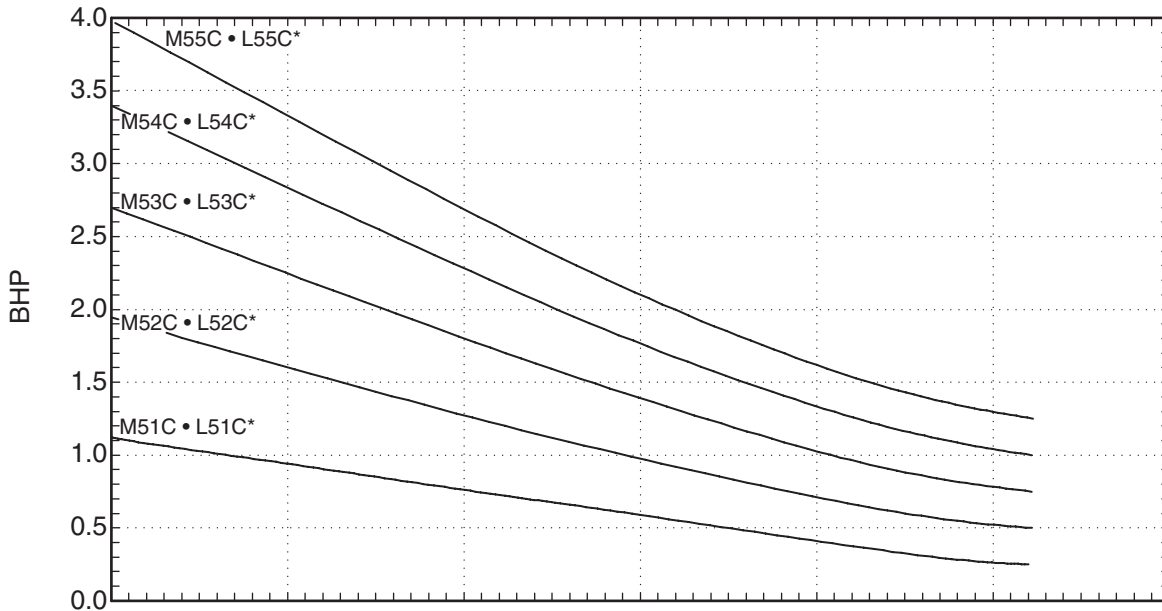
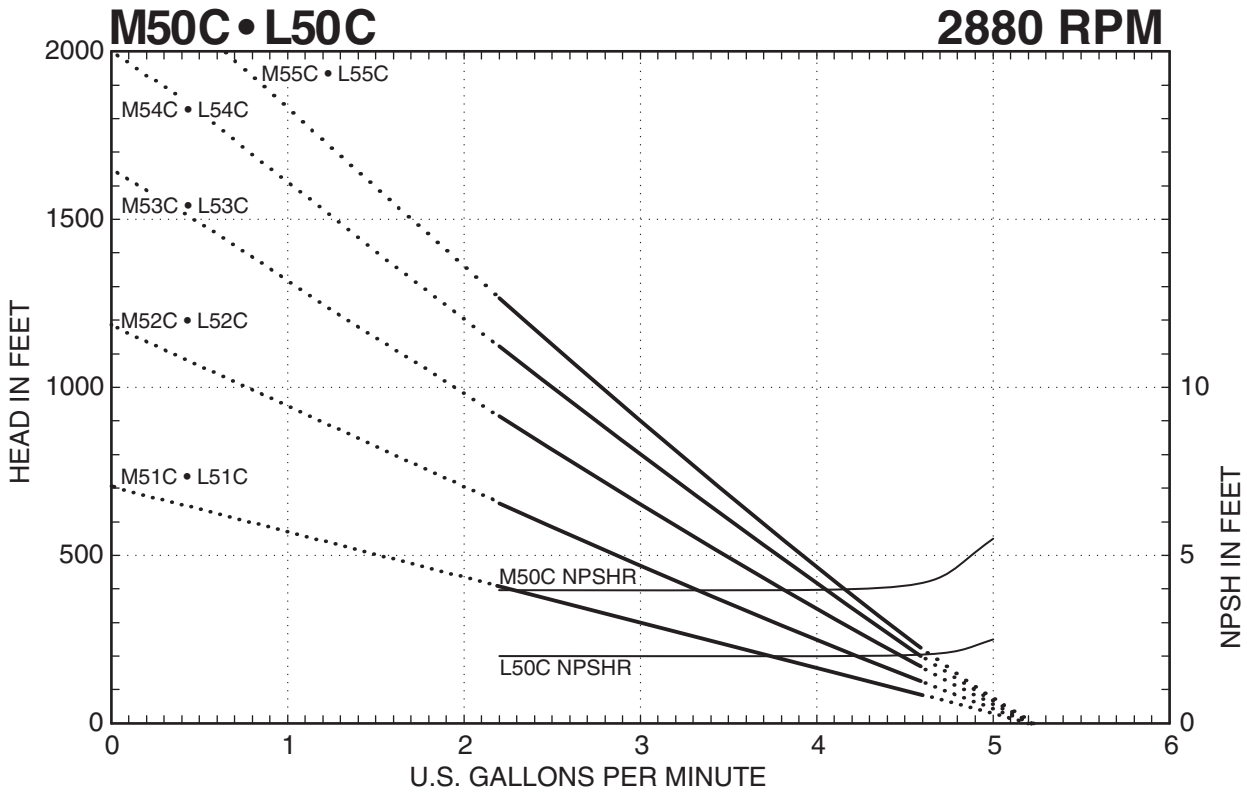

**NOTES**

- Recommended Operating Range
- ..... Refer to Factory for Operation in this Range
- \*Add .27 horsepower for L50C Inducer Models
- Horsepower data is valid for 1.0 specific gravity fluids only



**MTH PUMPS**

401 West Main Street • Plano, IL 60545-1436  
 Phone: 630-552-4115 • Fax: 630-552-3688  
 Email: SALES@MTHPUMPS.COM  
 http://WWW.MTHPUMPS.COM



M50 • L50 SERIES

# Performance Curves

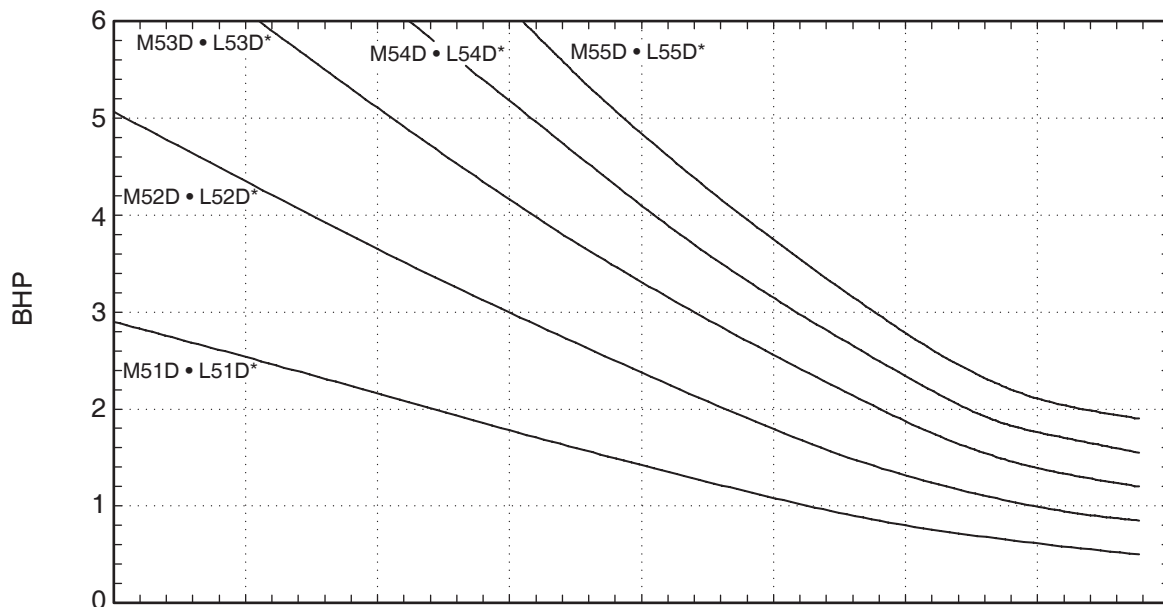
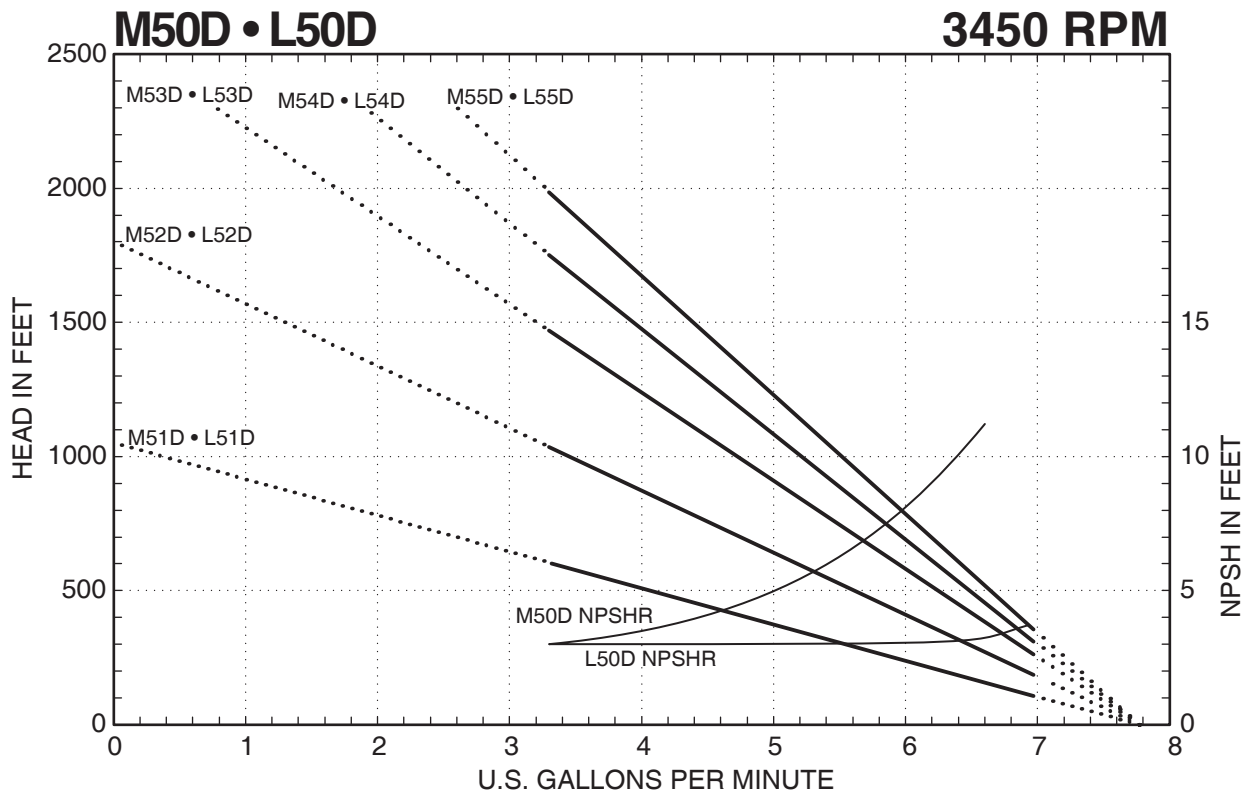

**NOTES**

- Recommended Operating Range
- ..... Refer to Factory for Operation in this Range
- \*Add .49 horsepower for L50D Inducer Models
- Horsepower data is valid for 1.0 specific gravity fluids only



401 West Main Street • Plano, IL 60545-1436  
 Phone: 630-552-4115 • Fax: 630-552-3688  
 Email: SALES@MTHPUMPS.COM  
 http://WWW.MTHPUMPS.COM

M50 • L50 SERIES PUMPS

# Performance Curves

M50 • L50 SERIES PUMPS

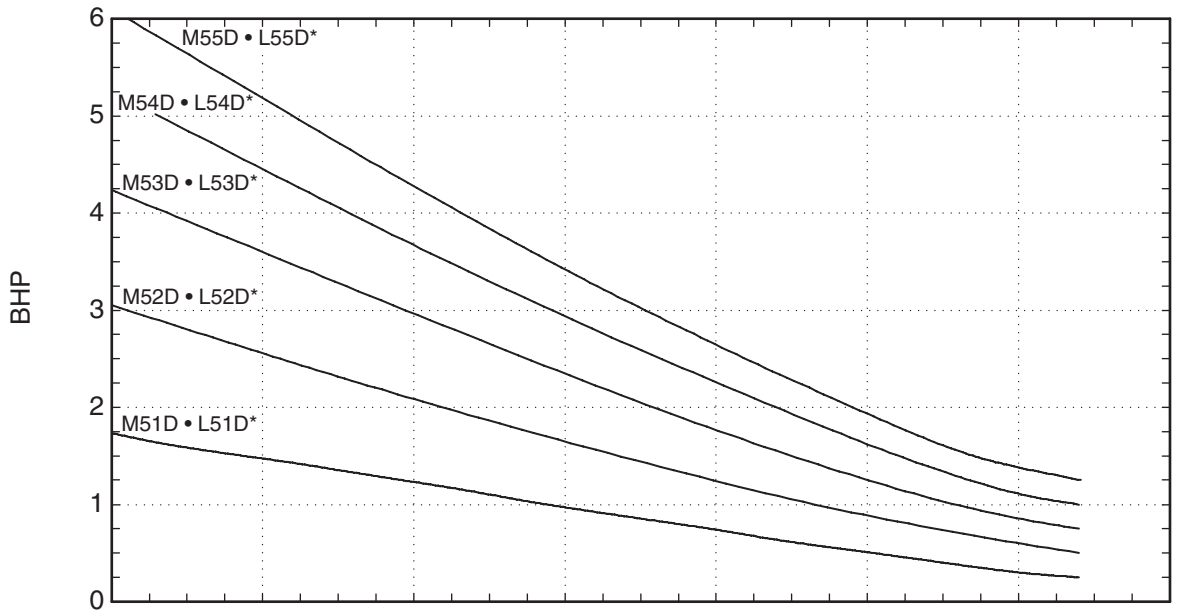
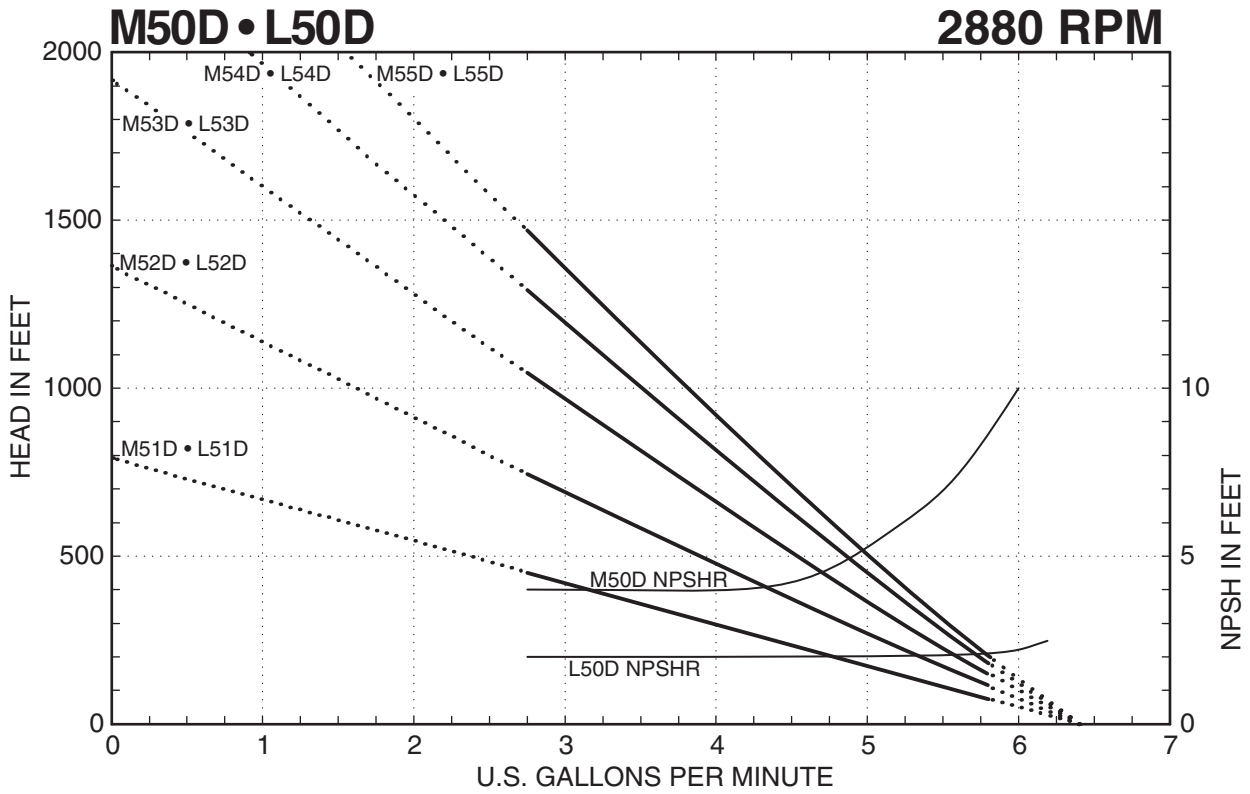

**NOTES**

- Recommended Operating Range
- ..... Refer to Factory for Operation in this Range
- \*Add .29 horsepower for L50D Inducer Models
- Horsepower data is valid for 1.0 specific gravity fluids only



**MTH PUMPS**  
 401 West Main Street • Plano, IL 60545-1436  
 Phone: 630-552-4115 • Fax: 630-552-3688  
 Email: SALES@MTHPUMPS.COM  
 http://WWW.MTHPUMPS.COM

M50 • L50 SERIES  
**Performance Curves**

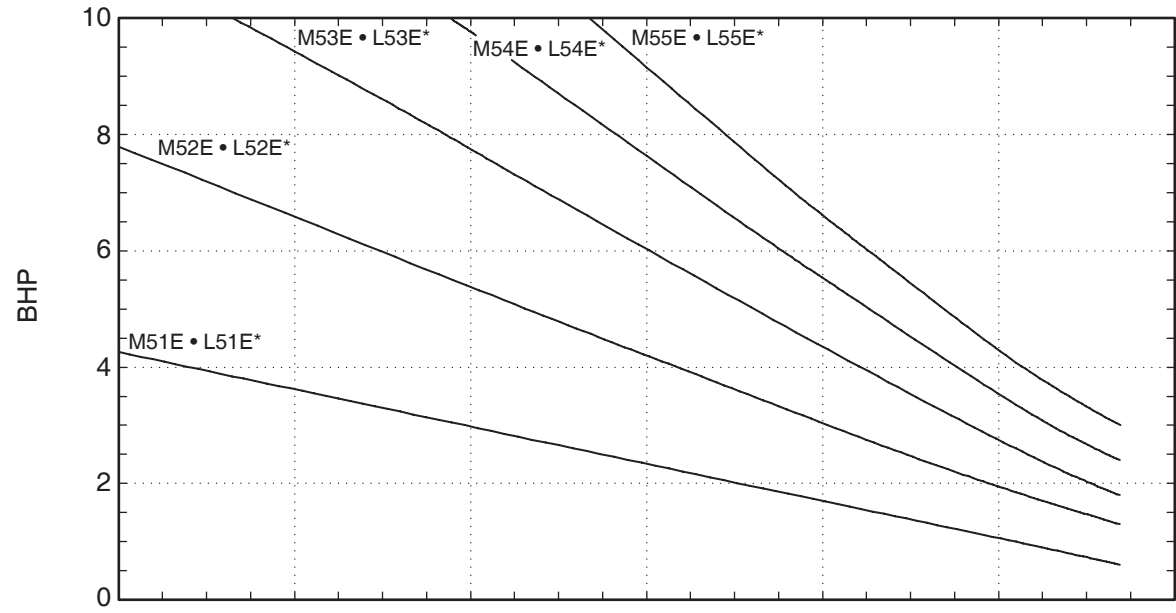
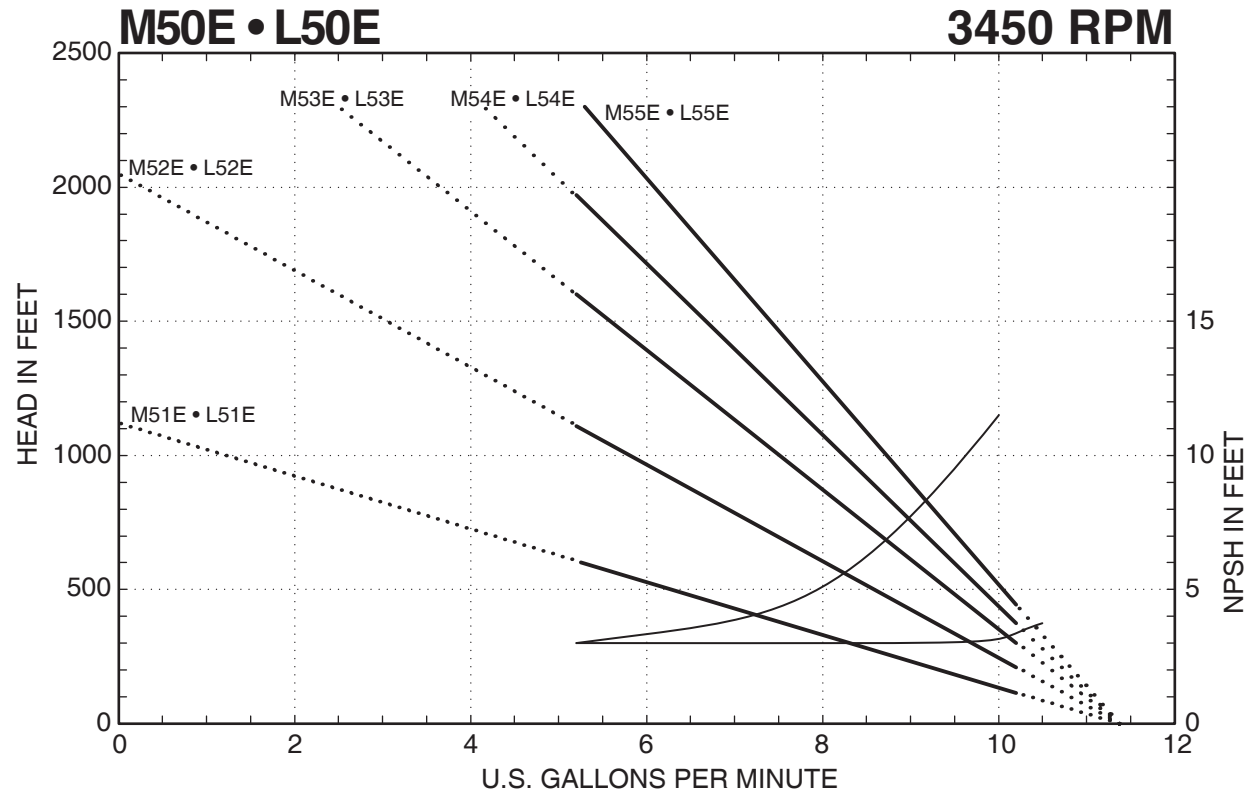

**NOTES**  
 ——— Recommended Operating Range  
 ..... Refer to Factory for Operation in this Range  
 \*Add .57 horsepower for L50E Inducer Models  
 Horsepower data is valid for 1.0 specific gravity fluids only

**MTH PUMPS**  
 401 West Main Street • Plano, IL 60545-1436  
 Phone: 630-552-4115 • Fax: 630-552-3688  
 Email: SALES@MTHPUMPS.COM  
 http://WWW.MTHPUMPS.COM

M50 • L50 SERIES PUMPS

M50 • L50 SERIES

# Performance Curves

M50 • L50 SERIES PUMPS

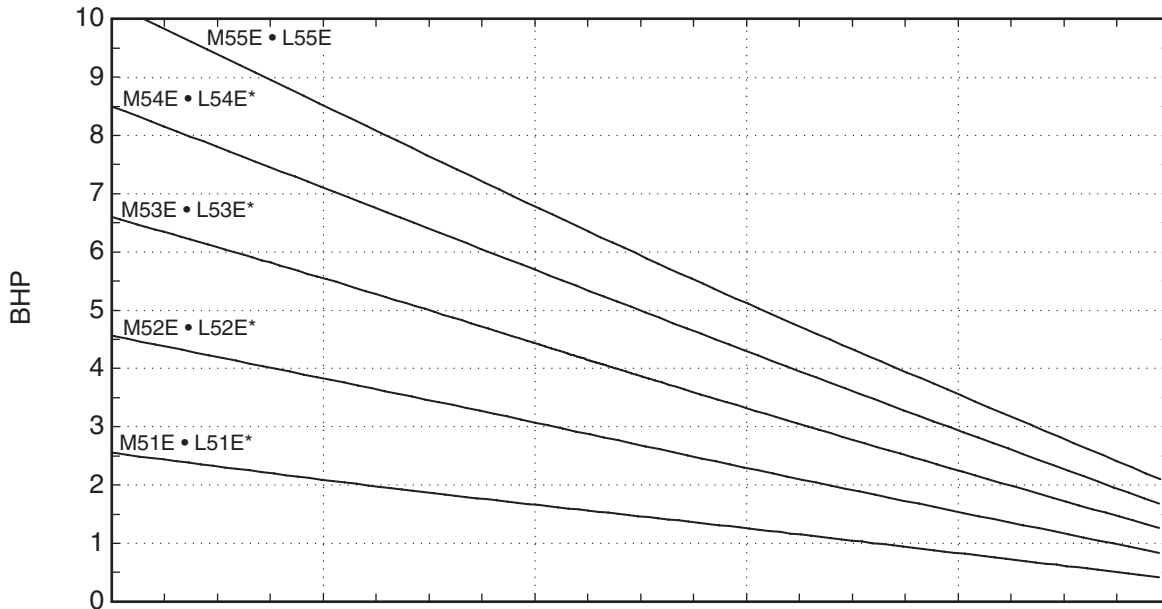
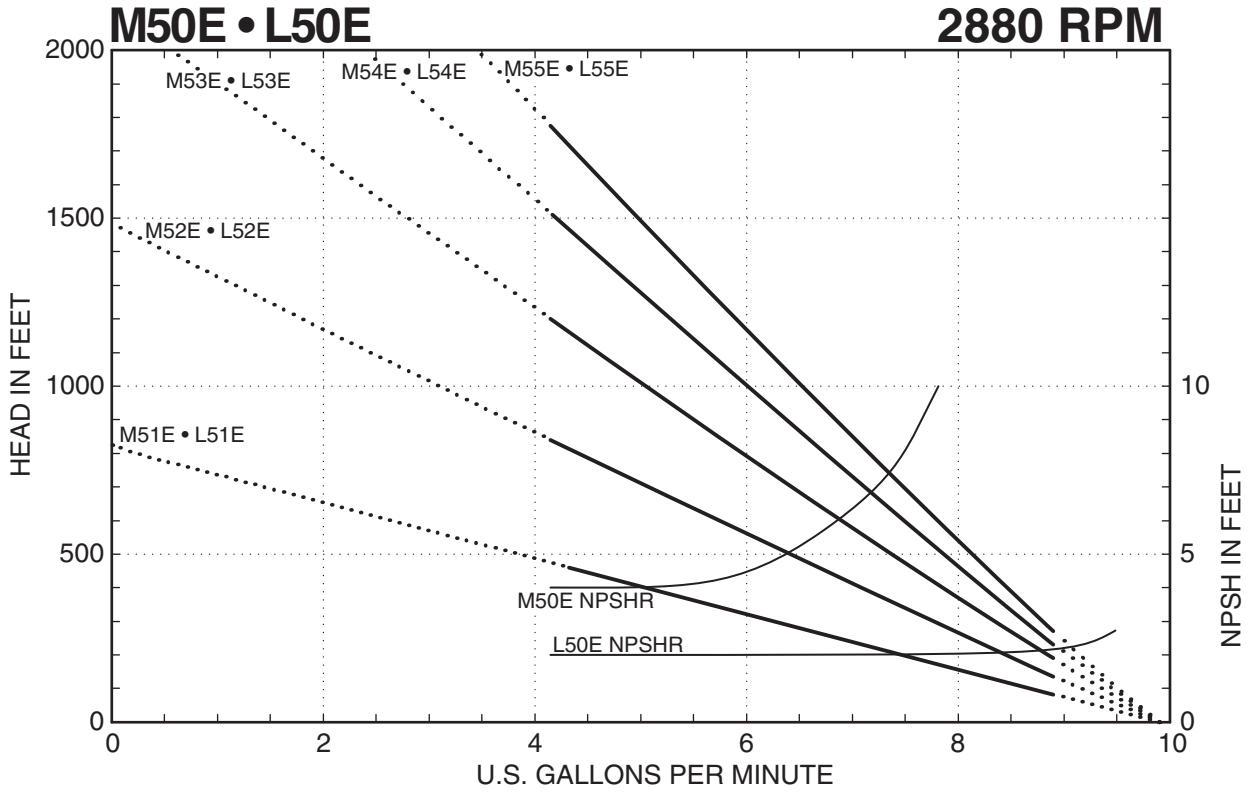

**NOTES**

- Recommended Operating Range
- ..... Refer to Factory for Operation in this Range
- \*Add .33 horsepower for L50E Inducer Models
- Horsepower data is valid for 1.0 specific gravity fluids only



**MTH PUMPS**

401 West Main Street • Plano, IL 60545-1436  
 Phone: 630-552-4115 • Fax: 630-552-3688  
 Email: SALES@MTHPUMPS.COM  
 http://WWW.MTHPUMPS.COM

M50 • L50 SERIES

# Performance Curves

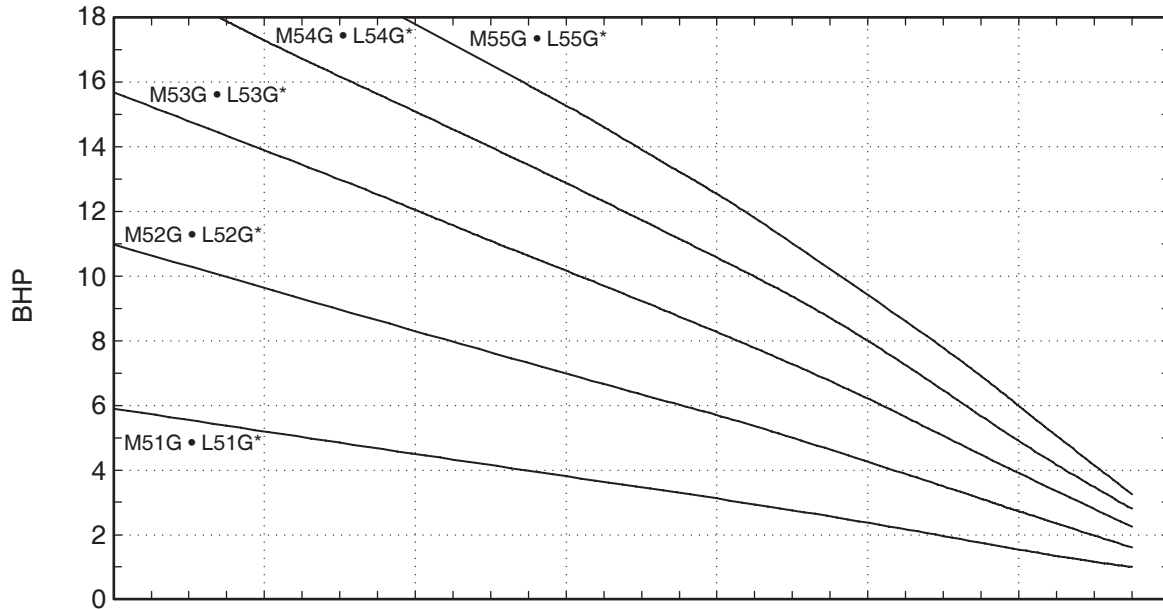
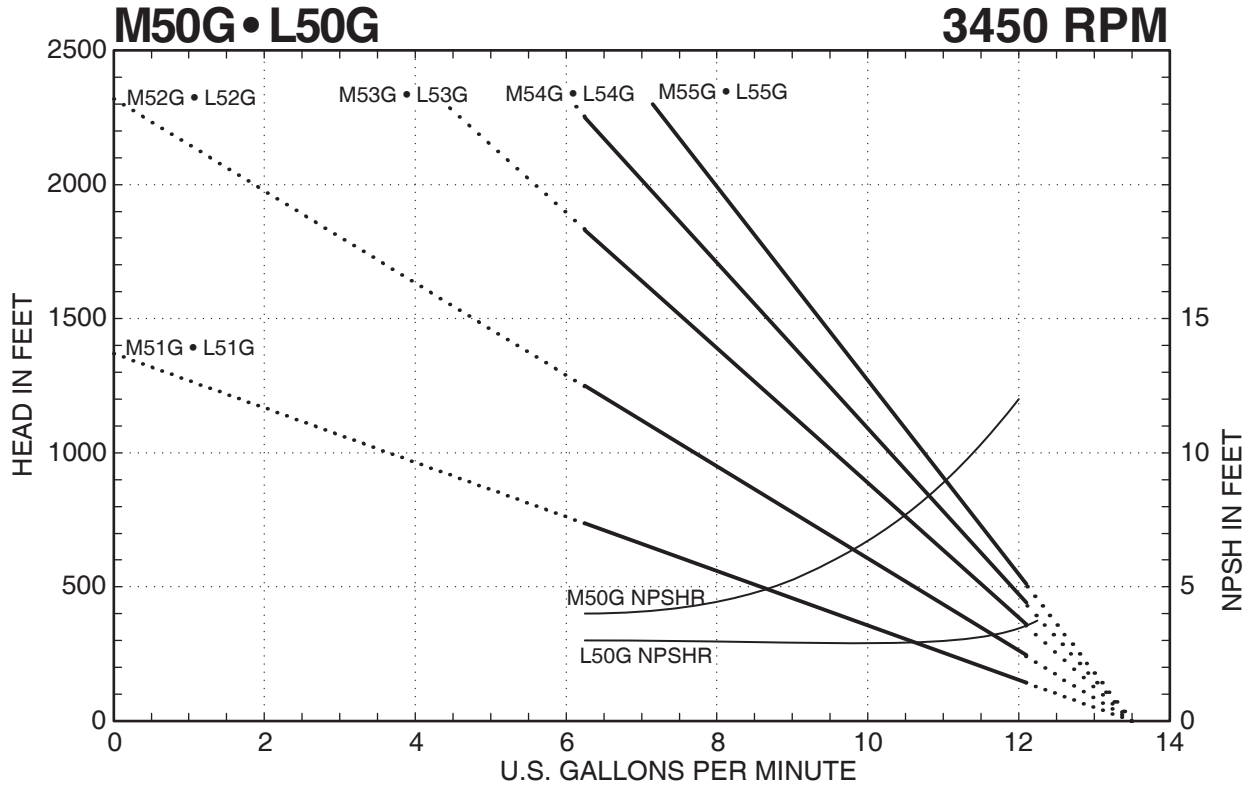

**NOTES**

- Recommended Operating Range
- ..... Refer to Factory for Operation in this Range
- \*Add .62 horsepower for L50G Inducer Models
- Horsepower data is valid for 1.0 specific gravity fluids only



401 West Main Street • Plano, IL 60545-1436  
 Phone: 630-552-4115 • Fax: 630-552-3688  
 Email: SALES@MTHPUMPS.COM  
 http://WWW.MTHPUMPS.COM

M50 • L50 SERIES PUMPS

M50 • L50 SERIES

# Performance Curves

M50 • L50 SERIES PUMPS

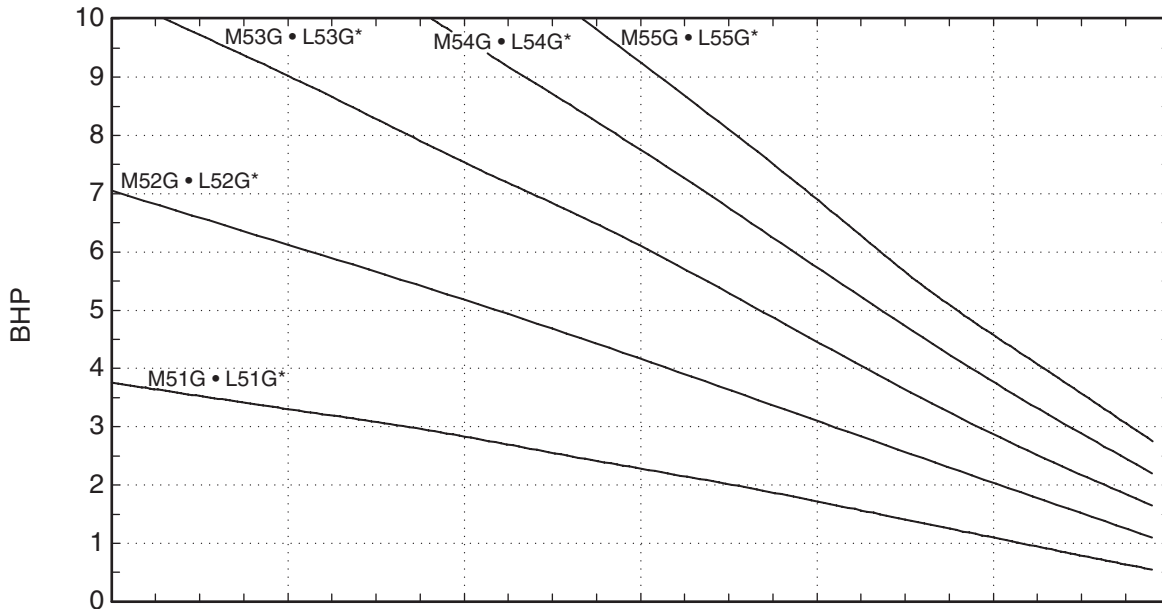
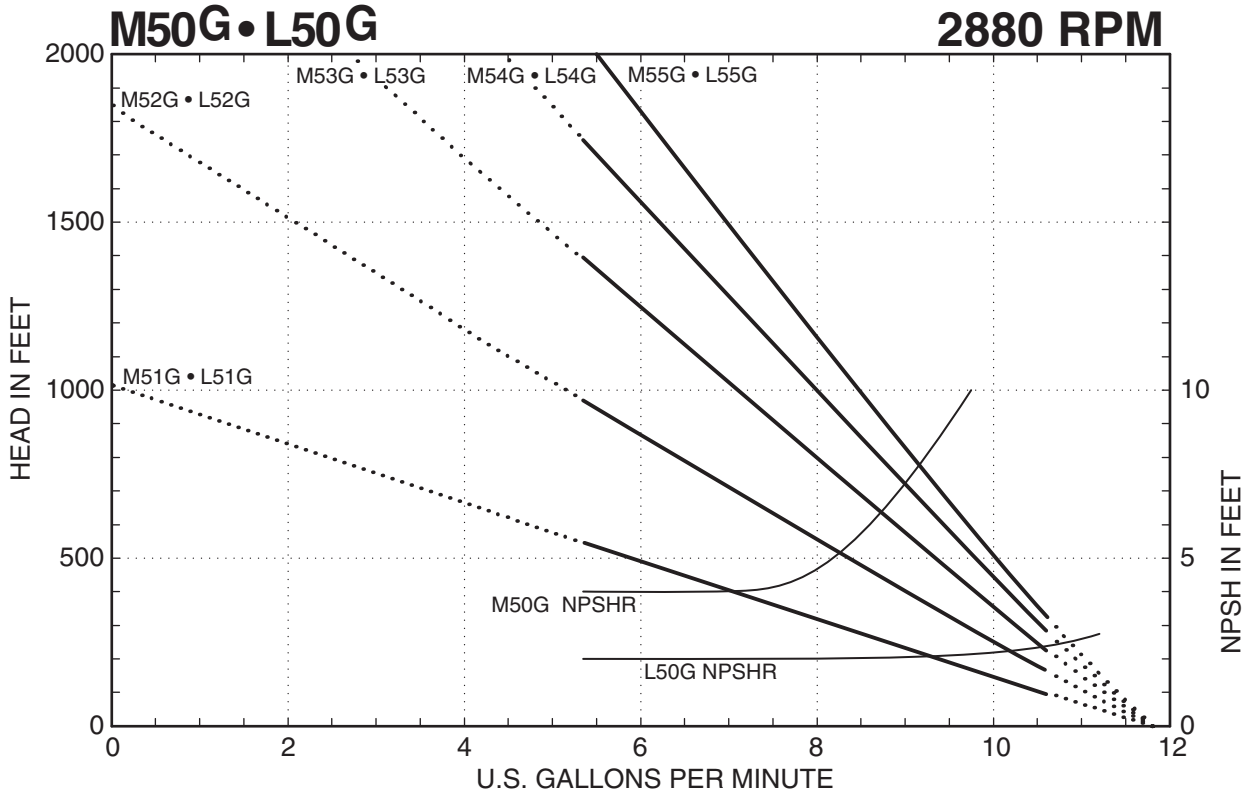

**NOTES**

- Recommended Operating Range
- ..... Refer to Factory for Operation in this Range
- \*Add .35 horsepower for L50G Inducer Models
- Horsepower data is valid for 1.0 specific gravity fluids only



**MTH PUMPS**

401 West Main Street • Plano, IL 60545-1436  
 Phone: 630-552-4115 • Fax: 630-552-3688  
 Email: SALES@MTHPUMPS.COM  
 http://WWW.MTHPUMPS.COM

M50 • L50 SERIES

# Performance Curves

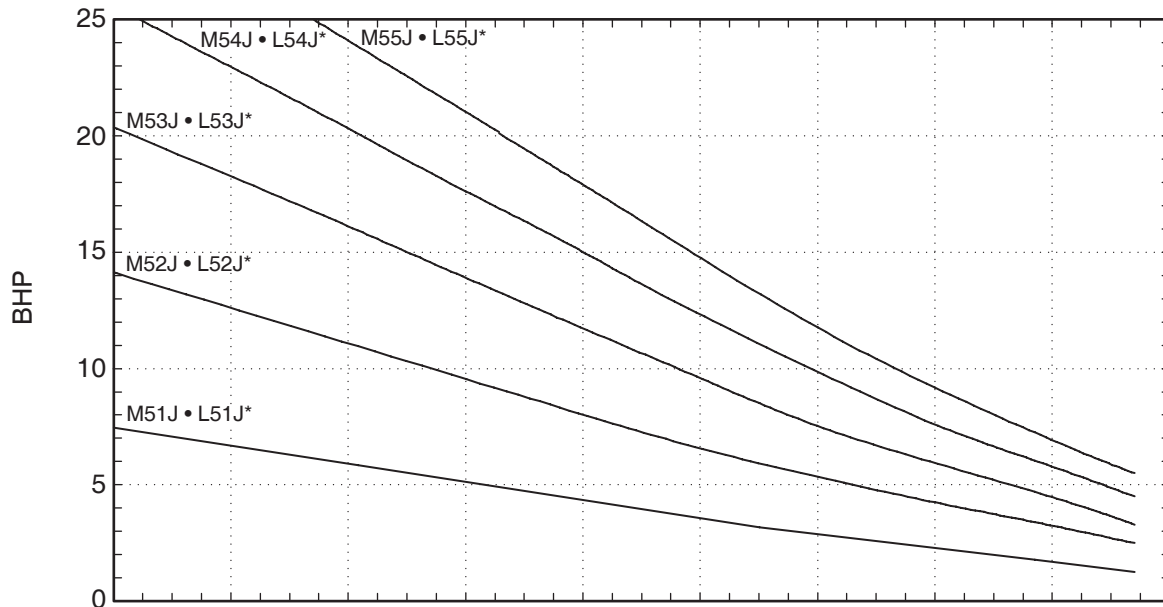
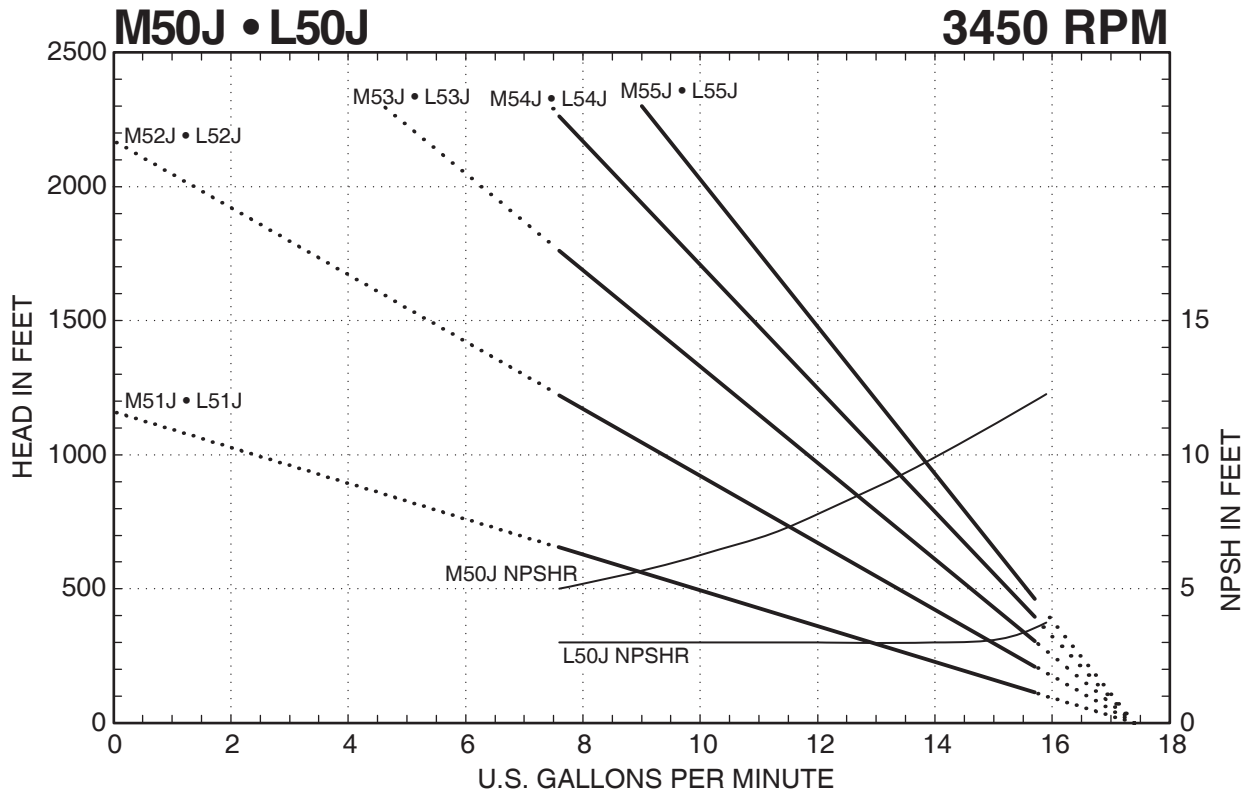

**NOTES**

————— Recommended Operating Range  
 ..... Refer to Factory for Operation in this Range  
 \*Add .70 horsepower for L50J Inducer Models  
 Horsepower data is valid for 1.0 specific gravity fluids only



401 West Main Street • Plano, IL 60545-1436  
 Phone: 630-552-4115 • Fax: 630-552-3688  
 Email: SALES@MTHPUMPS.COM  
 http://WWW.MTHPUMPS.COM

M50 • L50 SERIES PUMPS



# Performance Curves

M50 • L50 SERIES PUMPS

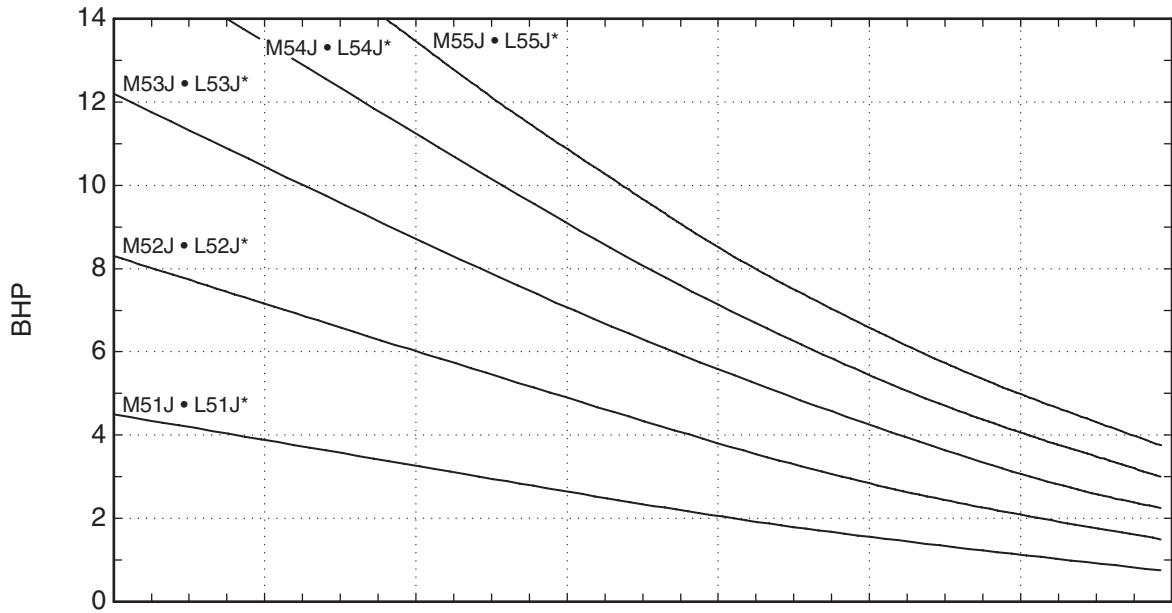
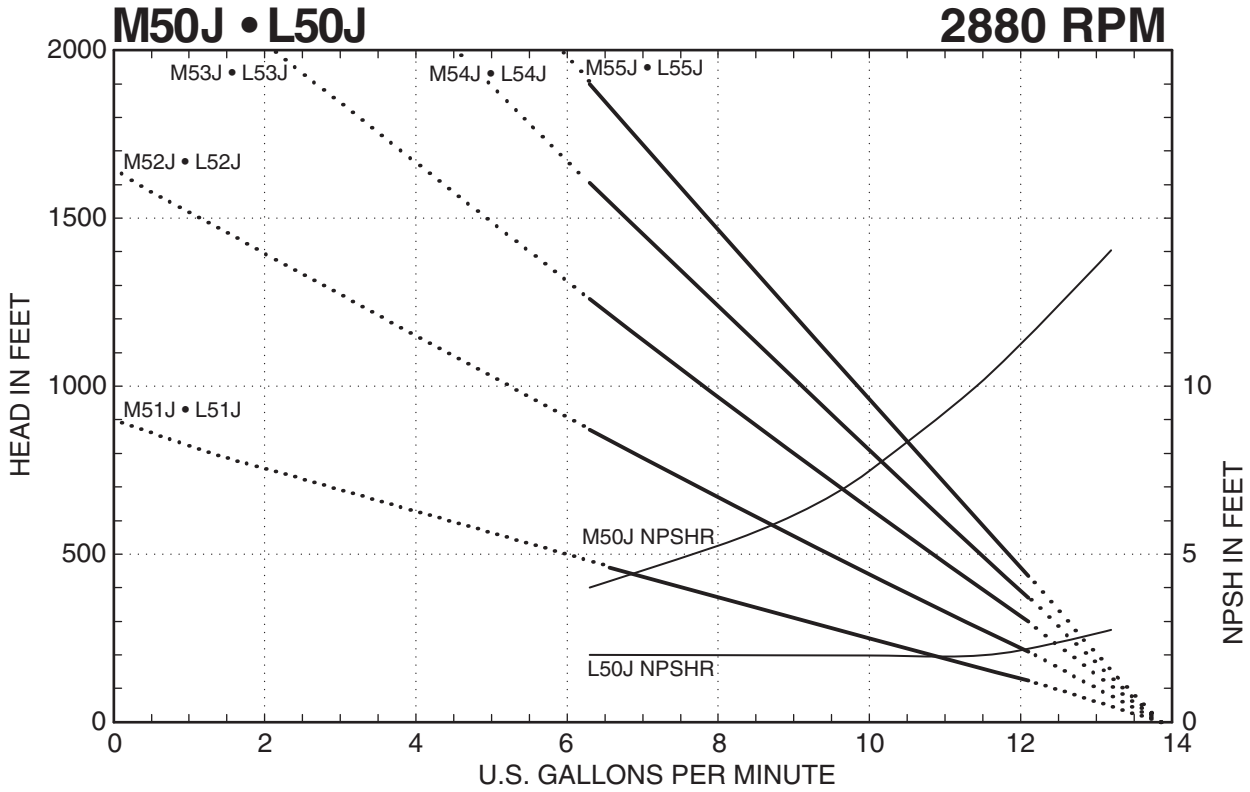

**NOTES**

- Recommended Operating Range
- ..... Refer to Factory for Operation in this Range
- \*Add .38 horsepower for L50J Inducer Models
- Horsepower data is valid for 1.0 specific gravity fluids only



**MTH PUMPS**

401 West Main Street • Plano, IL 60545-1436  
 Phone: 630-552-4115 • Fax: 630-552-3688  
 Email: SALES@MTHPUMPS.COM  
 http://WWW.MTHPUMPS.COM

M50 • L50 SERIES

# Performance Curves

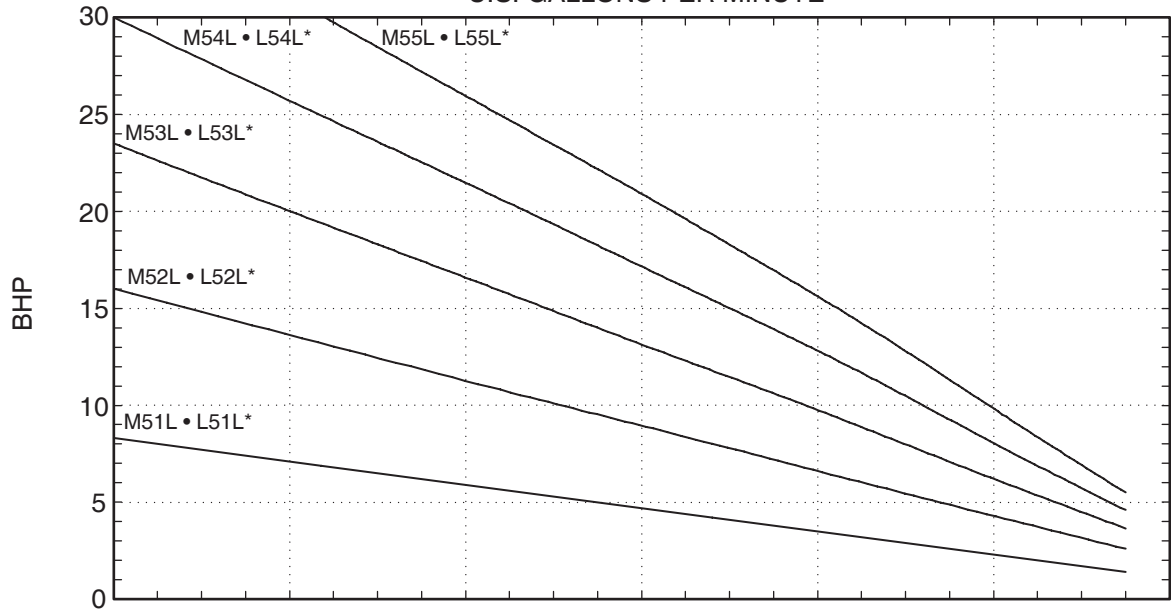
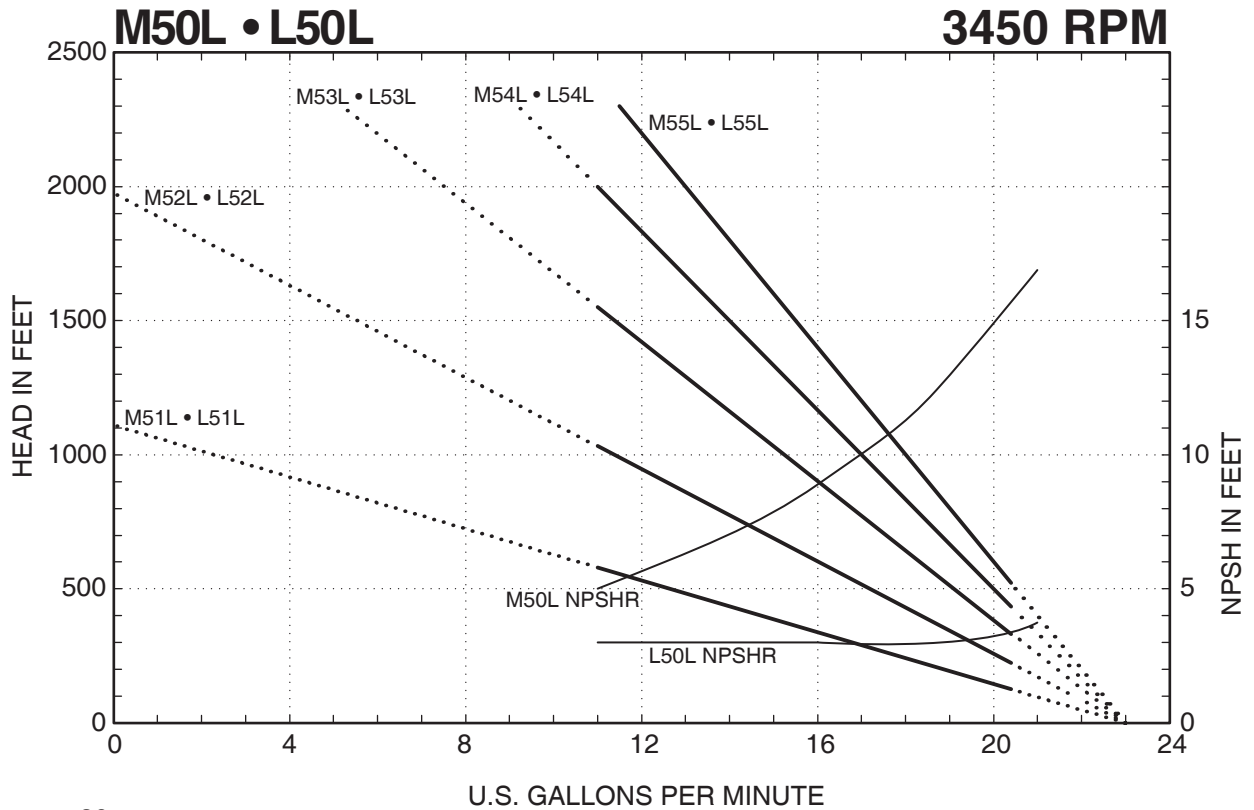

**NOTES**

- Recommended Operating Range
- ..... Refer to Factory for Operation in this Range
- \*Add .81 horsepower for L50L Inducer Models
- Horsepower data is valid for 1.0 specific gravity fluids only



**MTH PUMPS**

401 West Main Street • Plano, IL 60545-1436  
 Phone: 630-552-4115 • Fax: 630-552-3688  
 Email: SALES@MTHPUMPS.COM  
 http://WWW.MTHPUMPS.COM

**M50 • L50 SERIES PUMPS**

M50 • L50 SERIES

# Performance Curves

M50 • L50 SERIES PUMPS

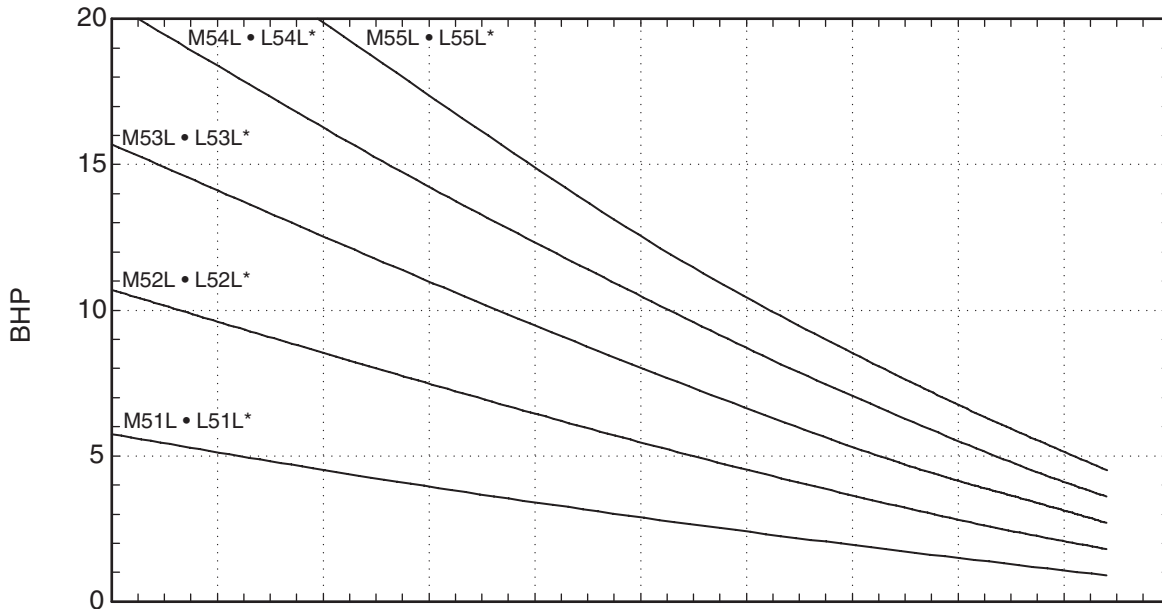
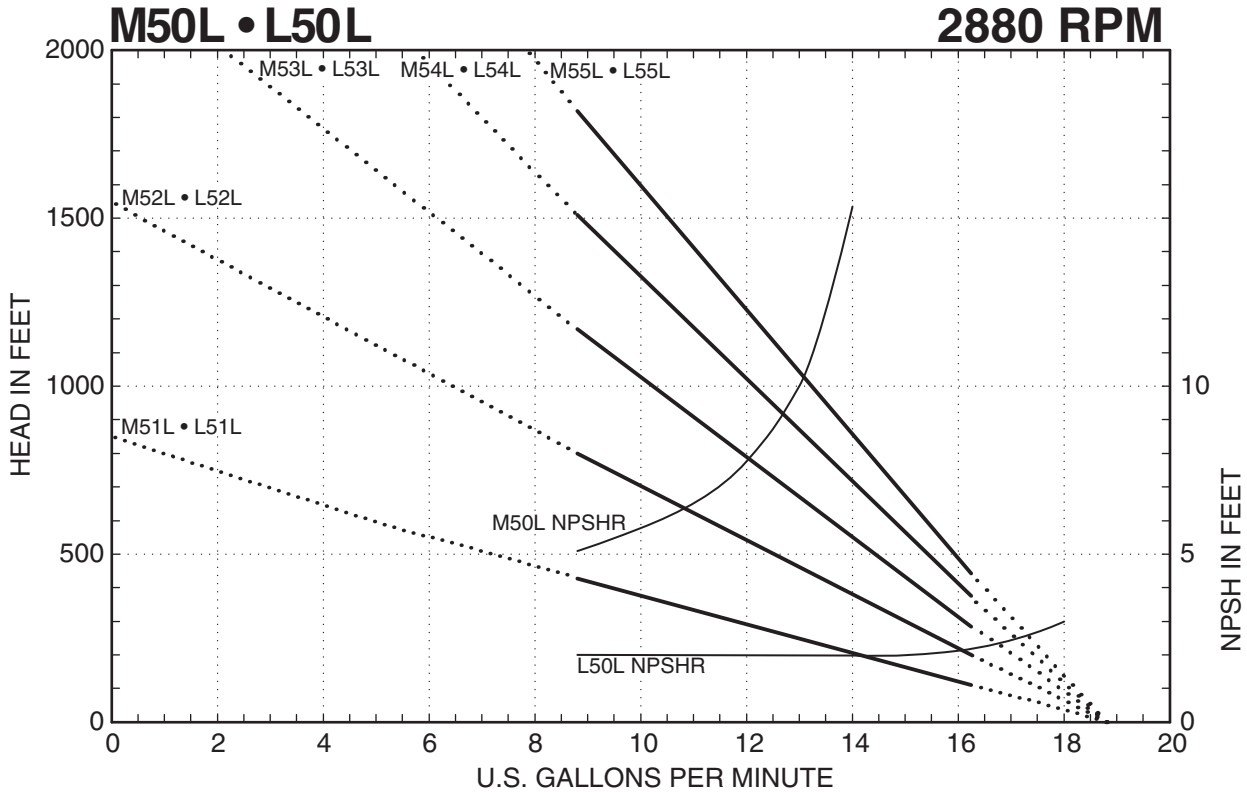

**NOTES**

- Recommended Operating Range
- ..... Refer to Factory for Operation in this Range
- \*Add .43 horsepower for L50L Inducer Models
- Horsepower data is valid for 1.0 specific gravity fluids only



**MTH PUMPS**

401 West Main Street • Plano, IL 60545-1436  
 Phone: 630-552-4115 • Fax: 630-552-3688  
 Email: SALES@MTHPUMPS.COM  
 http://WWW.MTHPUMPS.COM

M50 • L50 SERIES

# Performance Curves

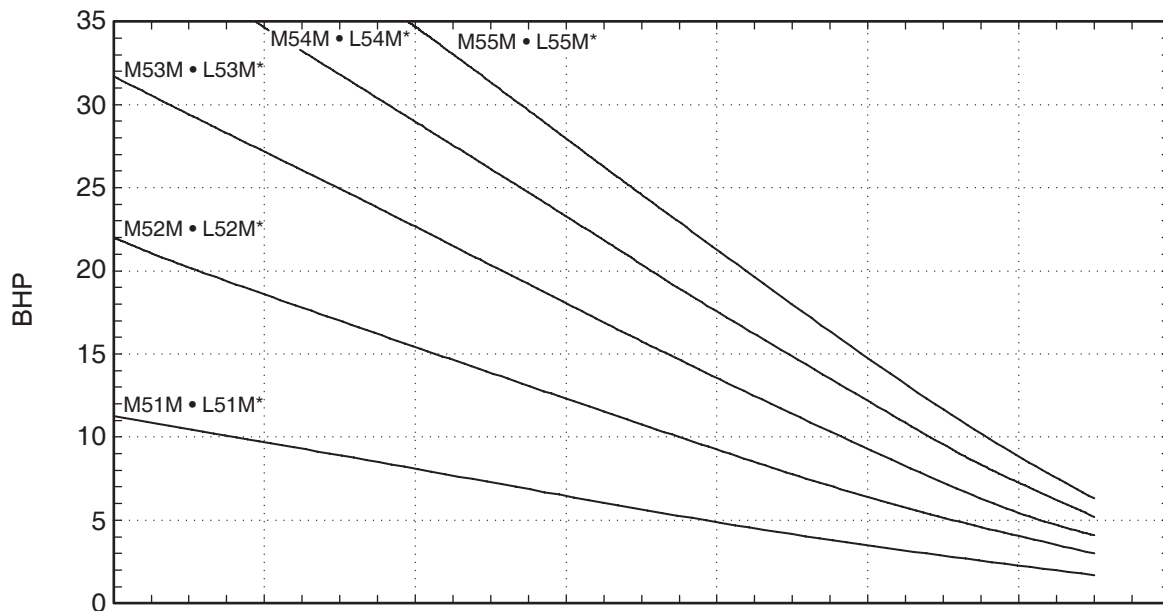
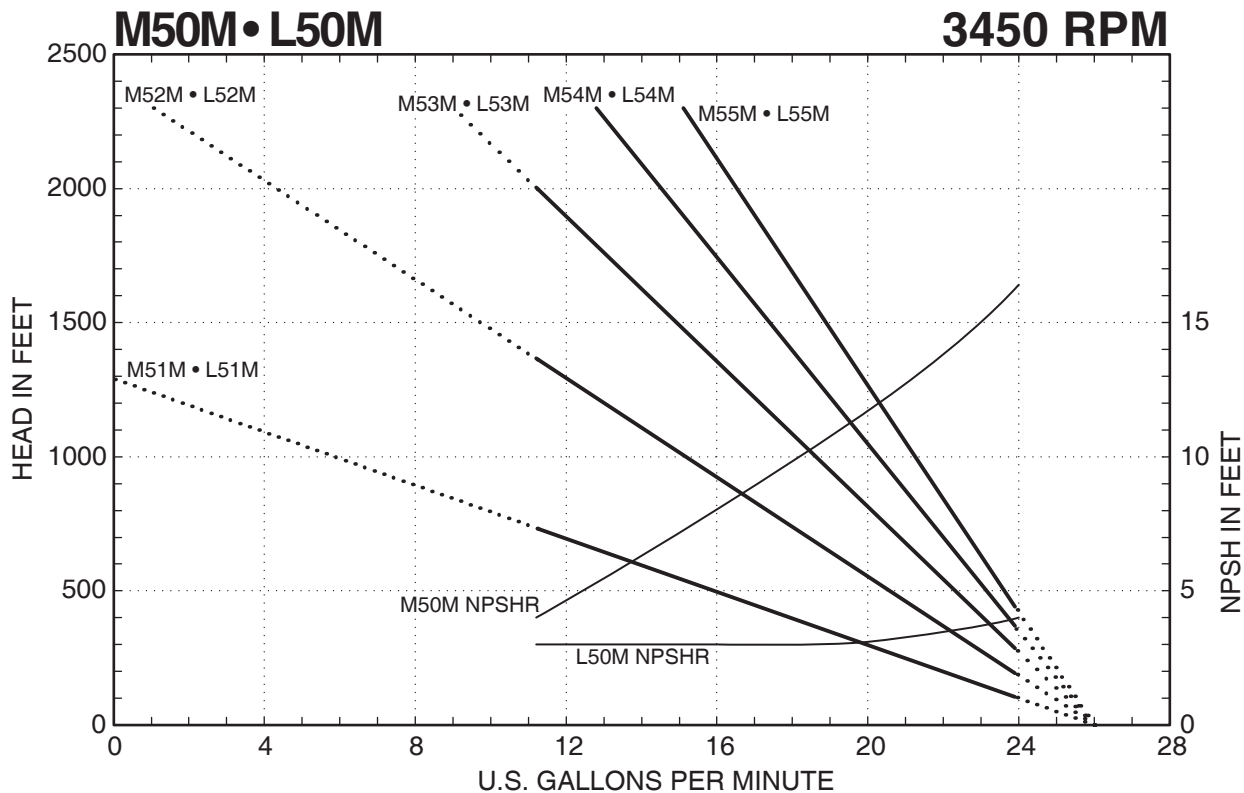

**NOTES**

————— Recommended Operating Range  
 ..... Refer to Factory for Operation in this Range  
 \*Add .86 horsepower for L50M Inducer Models  
 Horsepower data is valid for 1.0 specific gravity fluids only



**MTH PUMPS**

401 West Main Street • Plano, IL 60545-1436  
 Phone: 630-552-4115 • Fax: 630-552-3688  
 Email: SALES@MTHPUMPS.COM  
 http://WWW.MTHPUMPS.COM

M50 • L50 SERIES PUMPS

M50 • L50 SERIES

# Performance Curves

M50 • L50 SERIES PUMPS

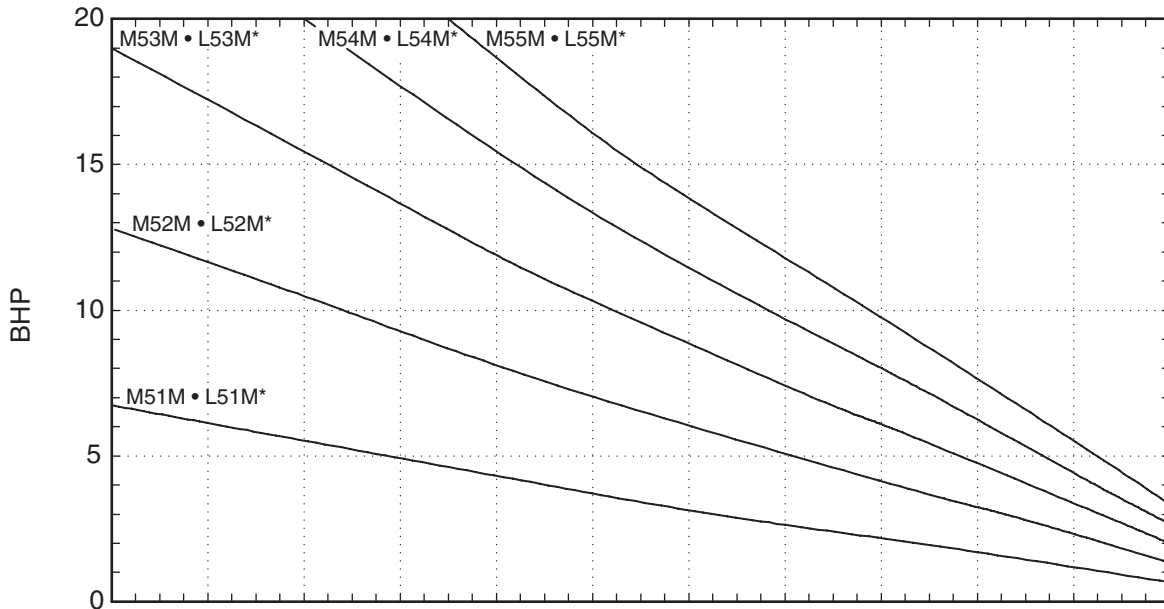
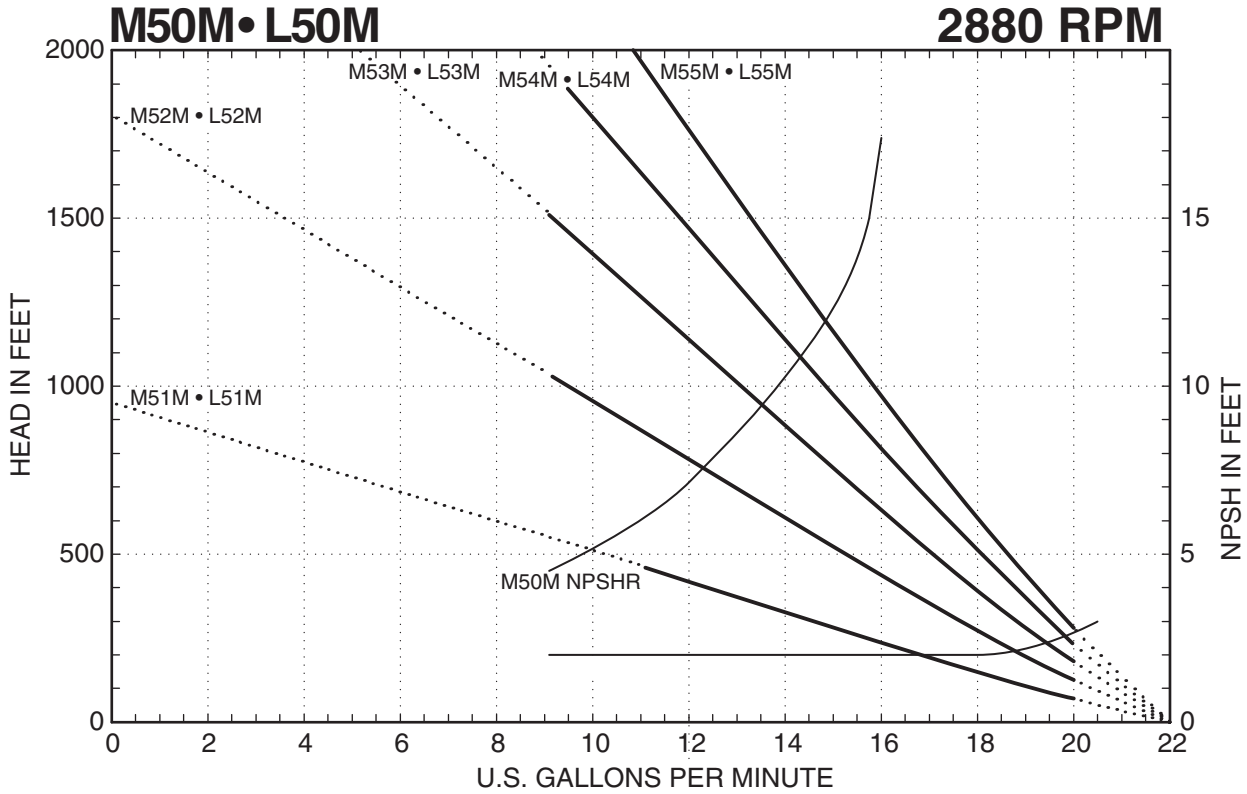

**NOTES**

- Recommended Operating Range
- ..... Refer to Factory for Operation in this Range
- \*Add .46 horsepower for L50M Inducer Models
- Horsepower data is valid for 1.0 specific gravity fluids only



**MTH PUMPS**

401 West Main Street • Plano, IL 60545-1436  
 Phone: 630-552-4115 • Fax: 630-552-3688  
 Email: SALES@MTHPUMPS.COM  
 http://WWW.MTHPUMPS.COM

M50 • L50 SERIES  
**Performance Curves**

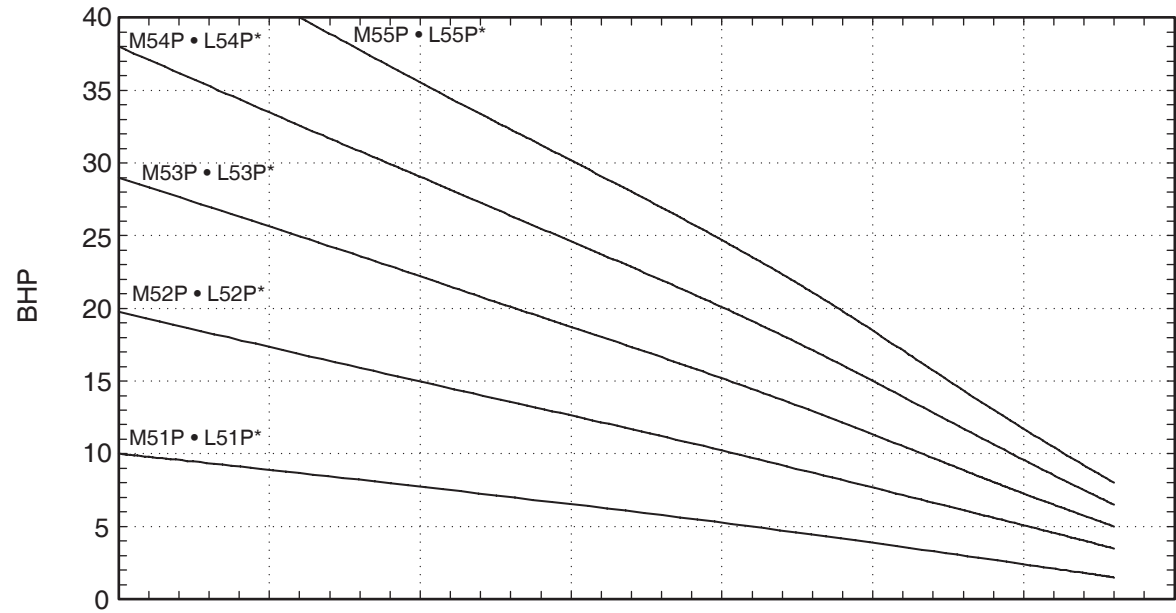
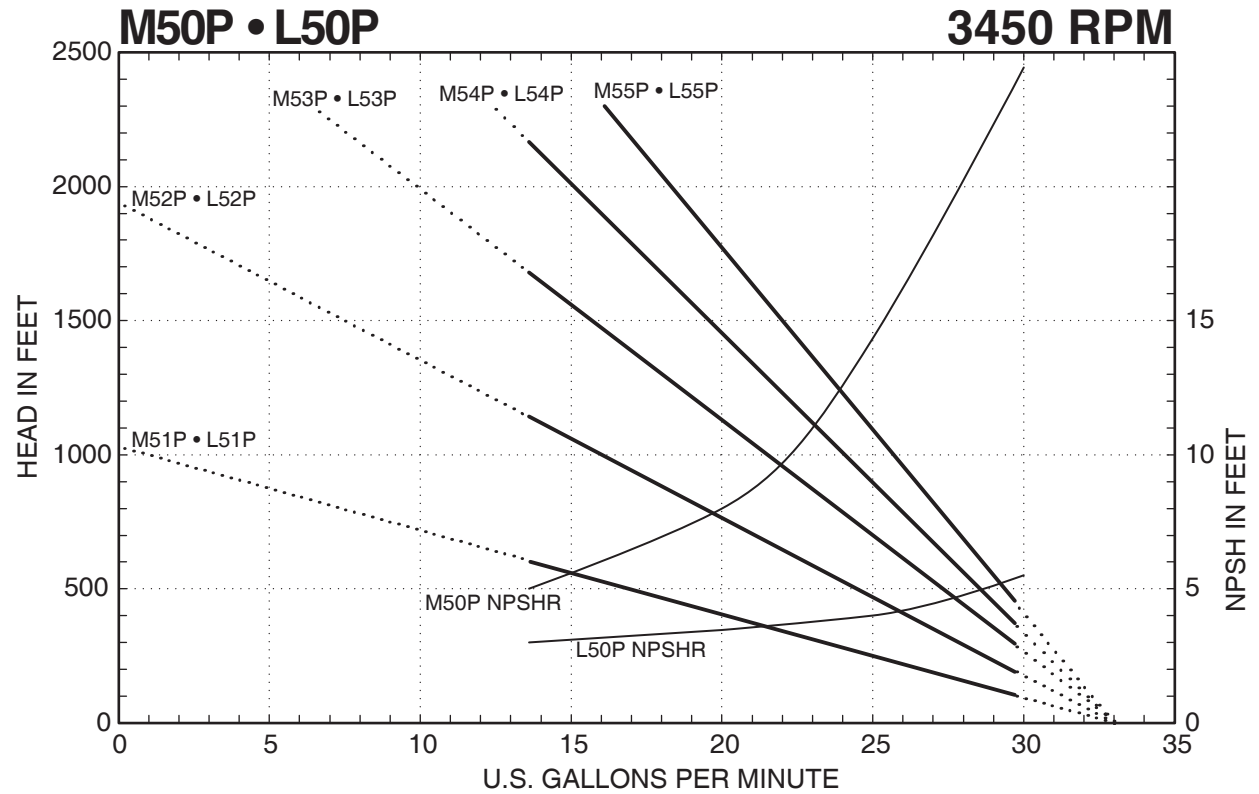

**NOTES**  
 ——— Recommended Operating Range  
 ..... Refer to Factory for Operation in this Range  
 \*Add .97 horsepower for L50P Inducer Models  
 Horsepower data is valid for 1.0 specific gravity fluids only



**MTH PUMPS**  
 401 West Main Street • Plano, IL 60545-1436  
 Phone: 630-552-4115 • Fax: 630-552-3688  
 Email: SALES@MTHPUMPS.COM  
 http://WWW.MTHPUMPS.COM

M50 • L50 SERIES PUMPS

M50 • L50 SERIES

# Performance Curves

M50 • L50 SERIES PUMPS

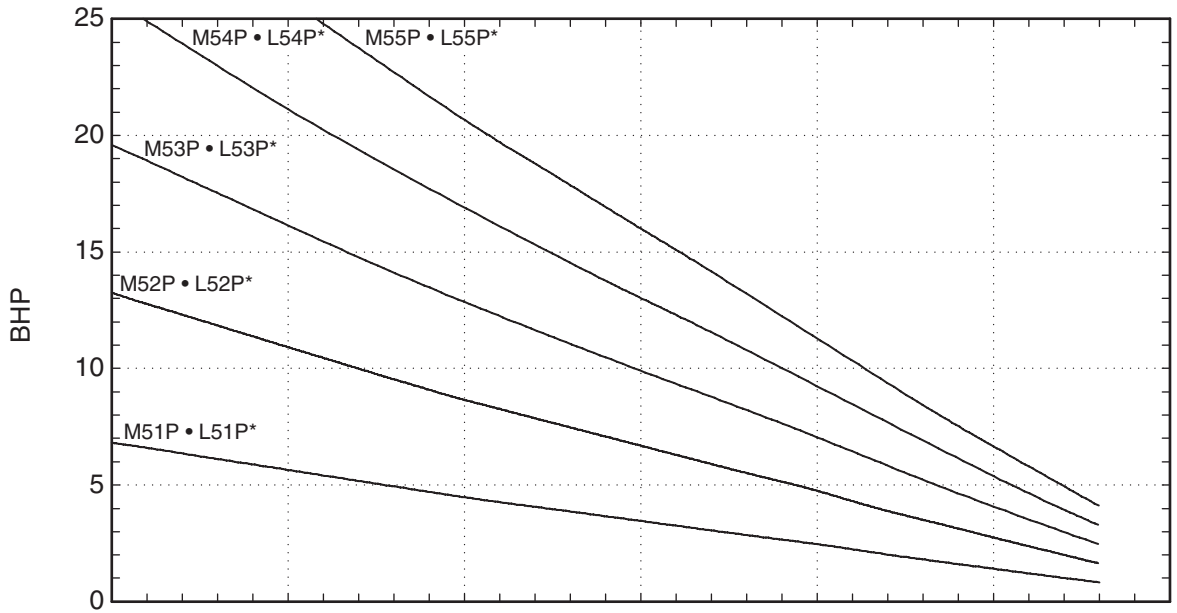
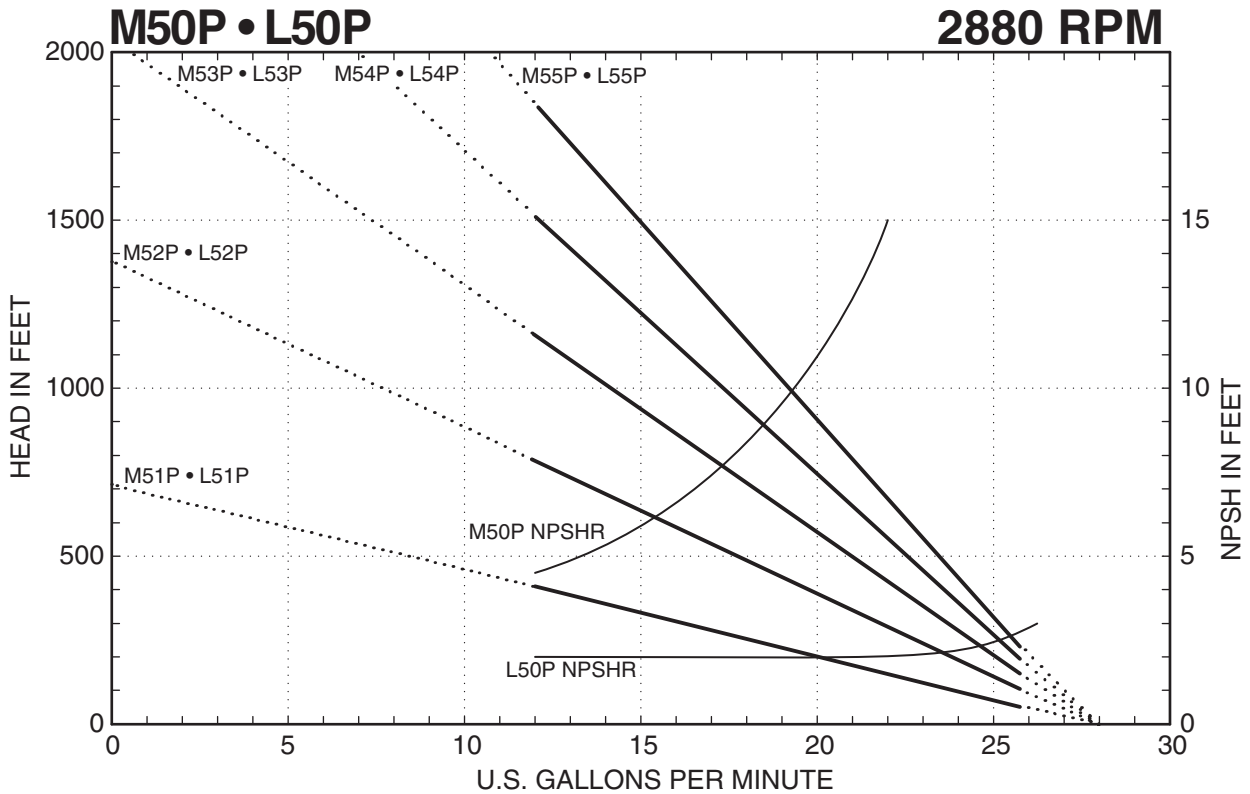

**NOTES**

- Recommended Operating Range
- ..... Refer to Factory for Operation in this Range
- \*Add .53 horsepower for L50P Inducer Models
- Horsepower data is valid for 1.0 specific gravity fluids only

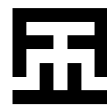

**MTH PUMPS**

401 West Main Street • Plano, IL 60545-1436  
 Phone: 630-552-4115 • Fax: 630-552-3688  
 Email: SALES@MTHPUMPS.COM  
 http://WWW.MTHPUMPS.COM



M50 • L50 SERIES

# Performance Curves

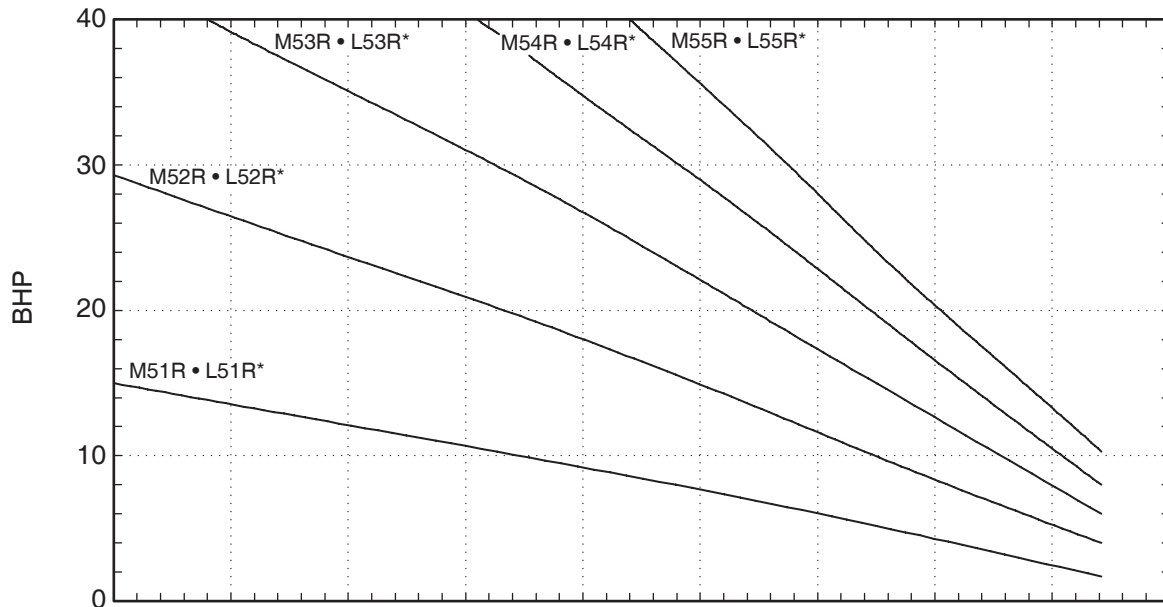
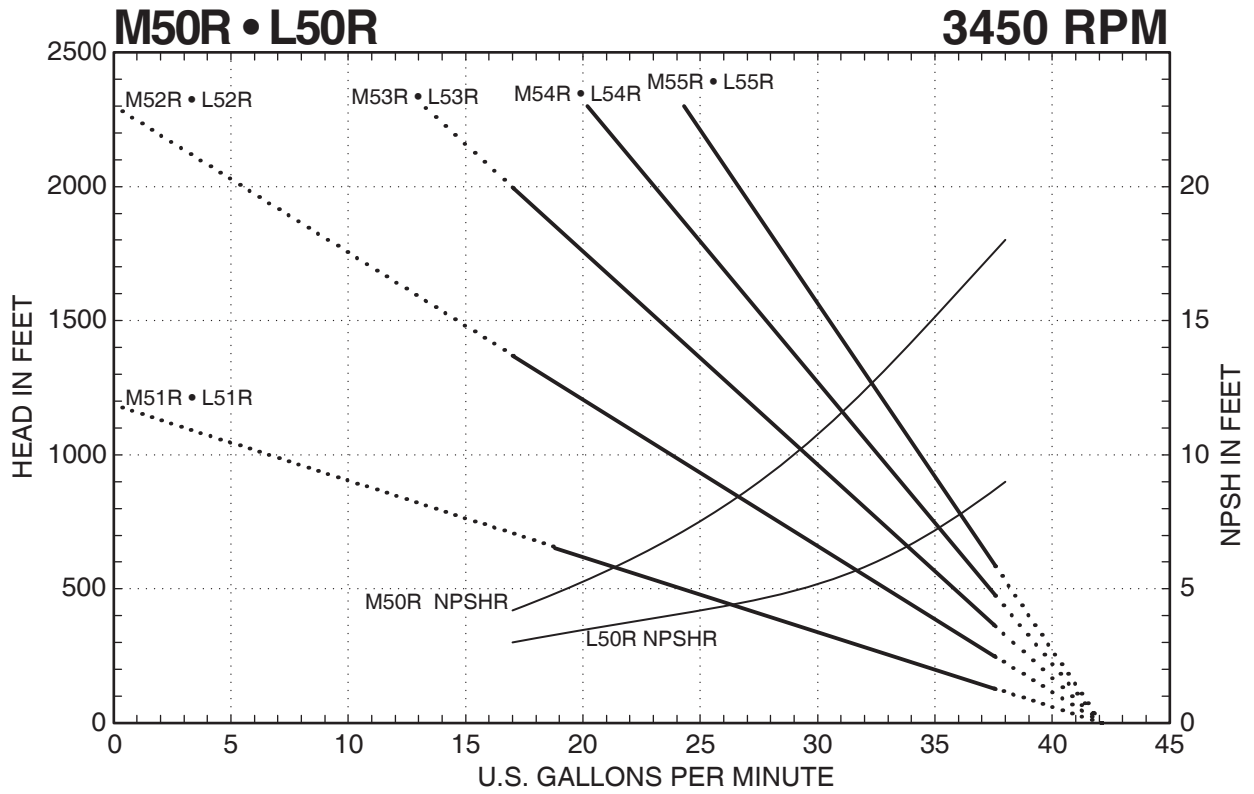

**NOTES**

- Recommended Operating Range
- ..... Refer to Factory for Operation in this Range
- \*Add 1.08 horsepower for L50R Inducer Models
- Horsepower data is valid for 1.0 specific gravity fluids only



401 West Main Street • Plano, IL 60545-1436  
 Phone: 630-552-4115 • Fax: 630-552-3688  
 Email: SALES@MTHPUMPS.COM  
 http://WWW.MTHPUMPS.COM

M50 • L50 SERIES PUMPS

# Performance Curves

M50 • L50 SERIES PUMPS

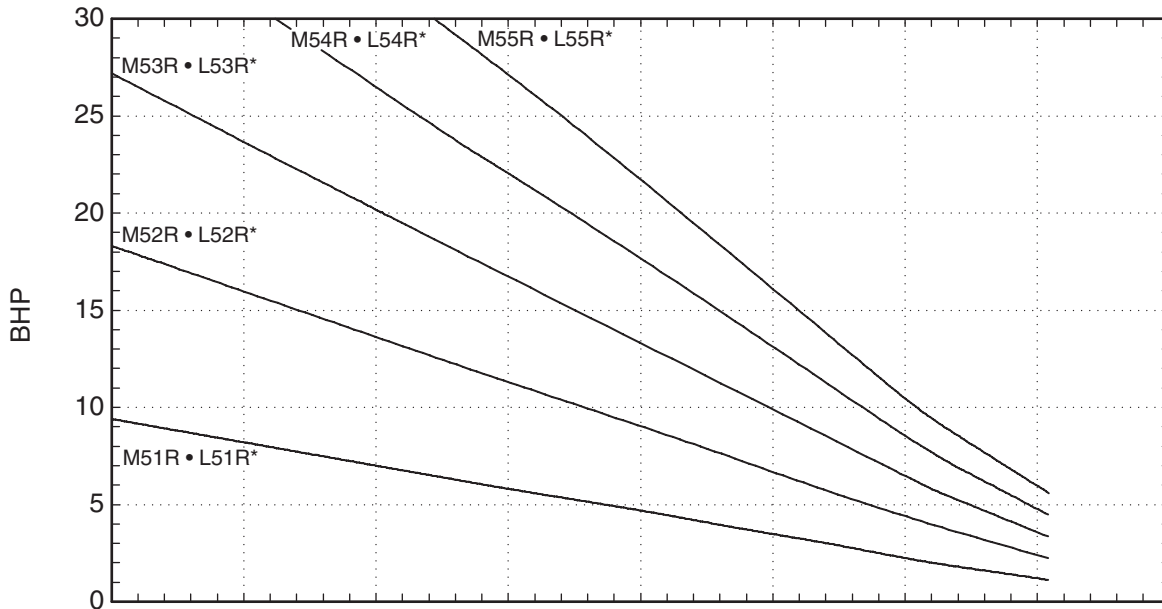
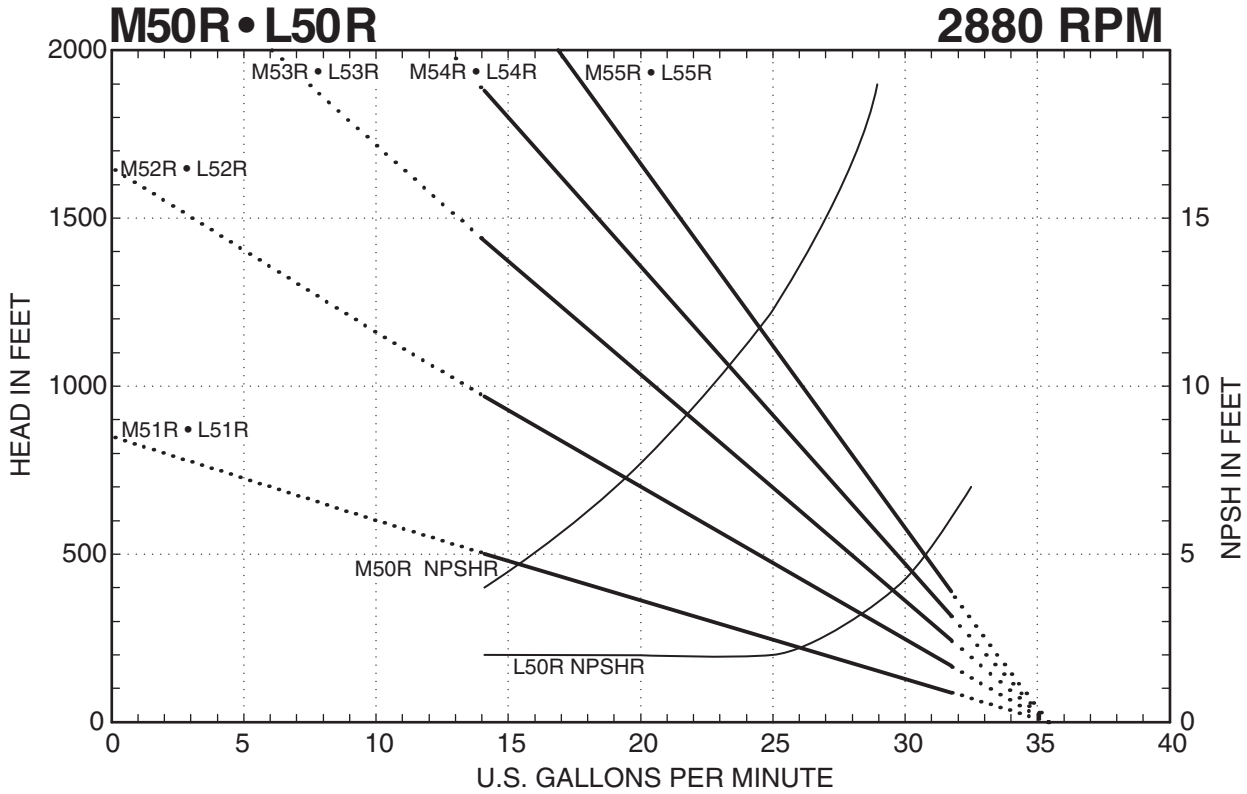

**NOTES**

- Recommended Operating Range
- ..... Refer to Factory for Operation in this Range
- \*Add .61 horsepower for L50R Inducer Models
- Horsepower data is valid for 1.0 specific gravity fluids only



**MTH PUMPS**

401 West Main Street • Plano, IL 60545-1436  
 Phone: 630-552-4115 • Fax: 630-552-3688  
 Email: SALES@MTHPUMPS.COM  
 http://WWW.MTHPUMPS.COM

# M50 • L50 SERIES Dimensions

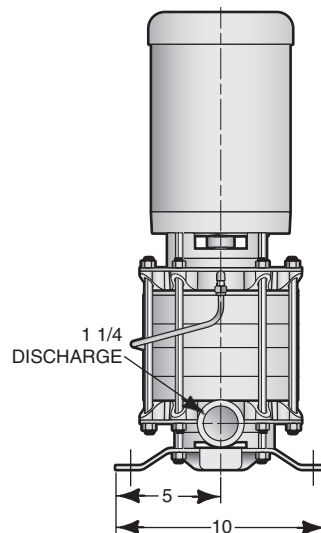
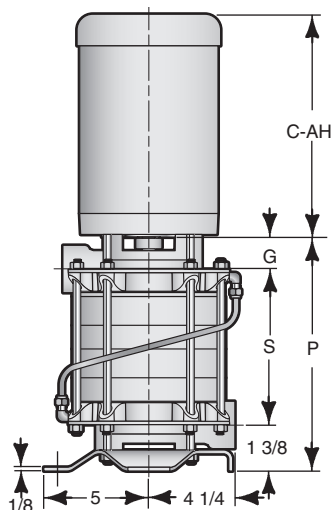
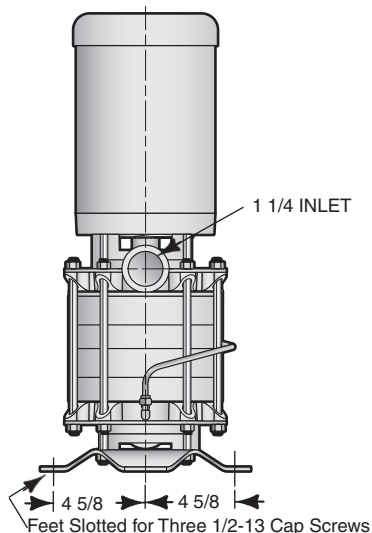

## M50 PUMPS WITHOUT INDUCER

FRAME	ALL		MODEL M51		MODEL M52		MODEL M53		MODEL M54		MODEL M55	
	C-AH	G	S	P	S	P	S	P	S	P	S	P
56C	13	13/16	SEE BELOW OR REFER TO T51 SERIES		7 1/2	10 1/16	10	12 9/16	12 1/2	15 1/16	15	17 9/16
143T-145T	13	13/16		7 1/2	10 1/16	10	12 9/16	12 1/2	15 1/16	15	17 9/16	
182T-184T	14 1/2	13/16		7 1/2	10 1/16	10	12 9/16	12 1/2	15 1/16	15	17 9/16	
213T-215T	17	13/16		7 1/2	10 1/16	10	12 9/16	12 1/2	15 1/16	15	17 9/16	
254T-256T	21 1/2	13/16		7 1/2	10 1/16	10	12 9/16	12 1/2	15 1/16	15	17 9/16	
284TS-286TS	23 1/2	13/16	7 1/2	10 1/16	10	12 9/16	12 1/2	15 1/16	15	17 9/16		

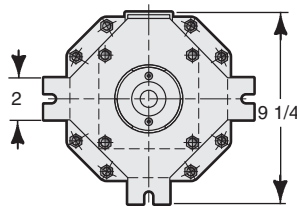

## L50 PUMPS WITH INDUCER

FRAME	ALL		MODEL L51		MODEL L52		MODEL L53		MODEL L54		MODEL L55	
	C-AH	G	S	P	S	P	S	P	S	P	S	P
56C	13	2 1/4	5 15/16	9 9/16	8 7/16	12 1/16	10 15/16	14 9/16	13 7/16	17 1/16	15 15/16	19 9/16
143T-145T	13	2 1/4	5 15/16	9 9/16	8 7/16	12 1/16	10 15/16	14 9/16	13 7/16	17 1/16	15 15/16	19 9/16
182T-184T	14 1/2	2 1/4	5 15/16	9 9/16	8 7/16	12 1/16	10 15/16	14 9/16	13 7/16	17 1/16	15 15/16	19 9/16
213T-215T	17	2 1/4	5 15/16	9 9/16	8 7/16	12 1/16	10 15/16	14 9/16	13 7/16	17 1/16	15 15/16	19 9/16
254T-256T	21 1/2	2 1/4	5 15/16	9 9/16	8 7/16	12 1/16	10 15/16	14 9/16	13 7/16	17 1/16	15 15/16	19 9/16
284TS-286TS	23 1/2	2 1/4	5 15/16	9 9/16	8 7/16	12 1/16	10 15/16	14 9/16	13 7/16	17 1/16	15 15/16	19 9/16

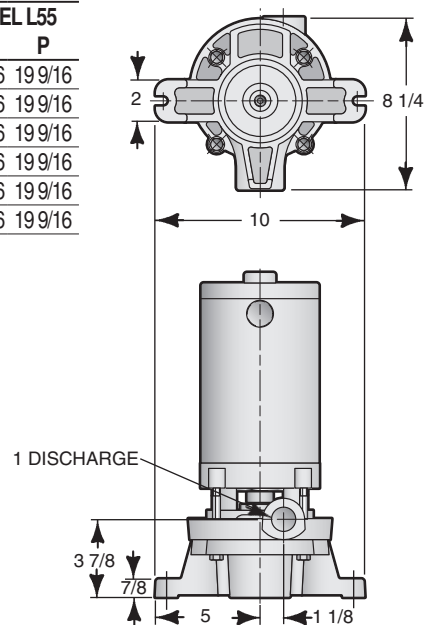
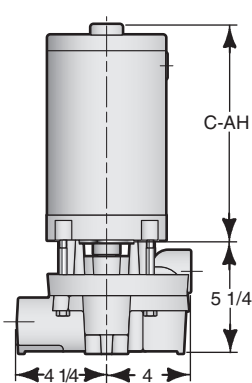
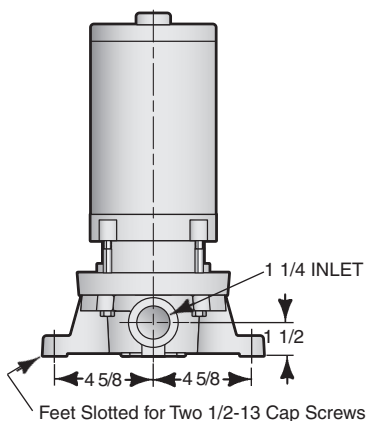

### NOTES

All dimensions in inches. May vary ± 1/4 inches.  
 Not for construction purposes unless certified.  
 \*See motor price sheet for C-AH dimension (varies depending on motor enclosure)  
 Model M52 shown in Multistage Dimensions. Model M51 shown in Single Stage Dimensions.



401 West Main Street • Plano, IL 60545-1436  
 Phone: 630-552-4115 • Fax: 630-552-3688  
 Email: SALES@MTHPUMPS.COM  
 http://WWW.MTHPUMPS.COM

M50 • L50 SERIES PUMPS

M50 • L50 SERIES  
**Dimensions**

M50 • L50 SERIES PUMPS

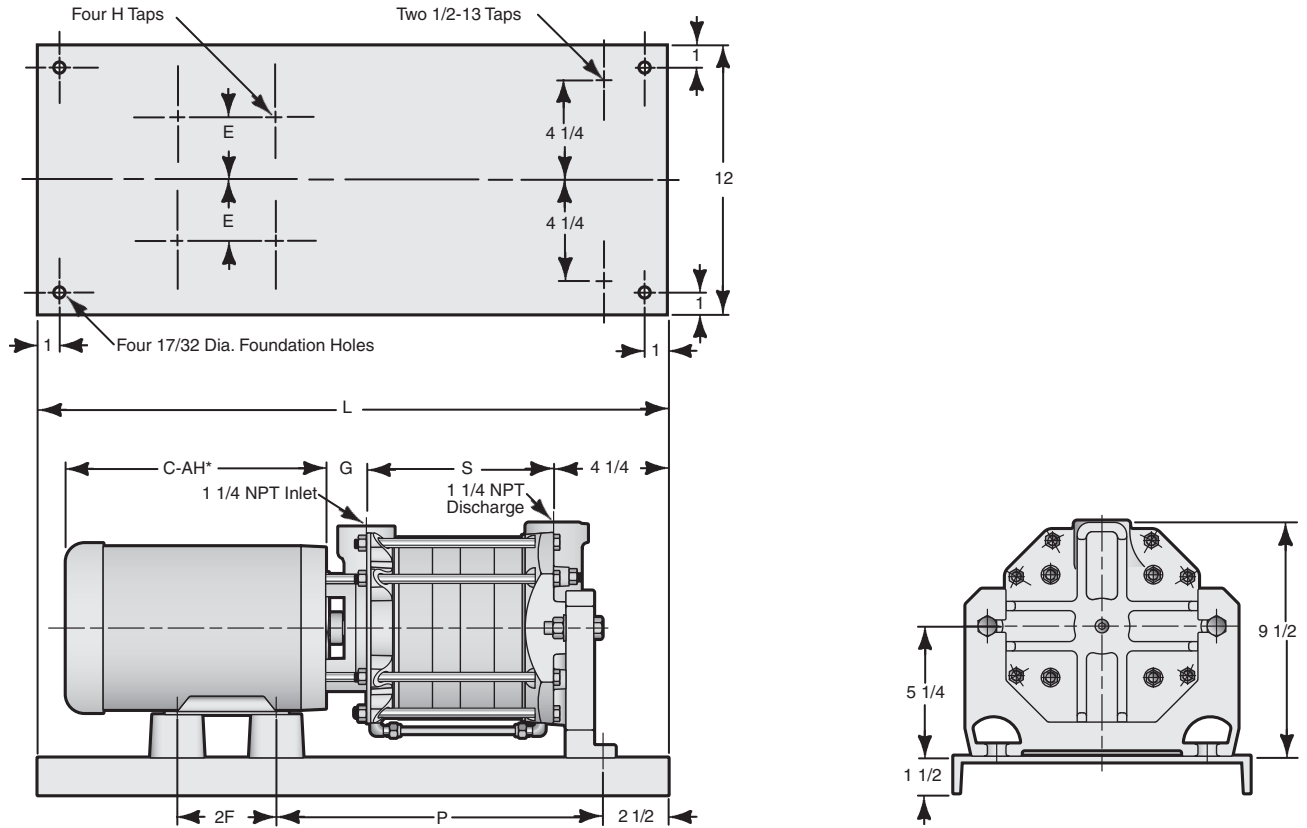

**M50 SERIES BASE MOUNTED CLOSE COUPLED WITH C3 MOTOR (WITHOUT INDUCER)**

FRAME	ALL M50 MODELS				MODEL M51			MODEL M52			MODEL M53			MODEL M54			MODEL M55				
	2F	E	H	G	S	P	L	S	P	L	S	P	L	S	P	L	S	P	L		
56C	3	2 7/16	5/16-18	1 3/16	REFER TO T51 SERIES				7 1/2	13 5/16	28	10	15 13/16	32	12 1/2	18 5/16	35	15	20 13/16	40	
143TC	4	2 3/4	5/16-18	1 3/16		7 1/2	13 1/2	28	10	16	32	12 1/2	18 1/2	35	15	21	40				
145TC	5	2 3/4	5/16-18	1 3/16		7 1/2	13 1/2	28	10	16	32	12 1/2	18 1/2	35	15	21	40				
182TC	4 1/2	3 3/4	3/8-16	1 3/16		7 1/2	14 1/4	30	10	16 3/4	32	12 1/2	19 1/4	35	15	21 3/4	40				

**L50 SERIES BASE MOUNTED CLOSE COUPLED WITH C3 MOTOR (WITH INDUCER)**

FRAME	ALL L50 MODELS				MODEL L51			MODEL L52			MODEL L53			MODEL L54			MODEL L55		
	2F	E	H	G	S	P	L	S	P	L	S	P	L	S	P	L	S	P	L
56C	3	2 7/16	5/16-18	2 1/4	5 15/16	12 3/4	28	8 7/16	15 1/4	30	10 15/16	17 3/4	32	13 7/16	20 1/4	35	15 15/16	22 3/4	40
143TC	4	2 3/4	5/16-18	2 1/4	5 15/16	12 15/16	28	8 7/16	15 7/16	30	10 15/16	17 15/16	32	13 7/16	20 7/16	35	15 15/16	22 15/16	40
145TC	5	2 3/4	5/16-18	2 1/4	5 15/16	12 15/16	28	8 7/16	15 7/16	30	10 15/16	17 15/16	32	13 7/16	20 7/16	35	15 15/16	22 15/16	40
182TC	4 1/2	3 3/4	3/8-16	2 1/4	5 15/16	13 11/16	30	8 7/16	16 3/16	32	10 15/16	18 11/16	35	13 7/16	21 3/16	40	15 15/16	23 11/16	40

**NOTES**

All dimensions in inches. May vary ± 1/4 inches.  
 Not for construction purposes unless certified.  
 \*See motor price sheet for C-AH dimension (varies depending on motor enclosure)



401 West Main Street • Plano, IL 60545-1436  
 Phone: 630-552-4115 • Fax: 630-552-3688  
 Email: SALES@MTHPUMPS.COM  
 http://WWW.MTHPUMPS.COM

## M50 • L50 SERIES

## Dimensions

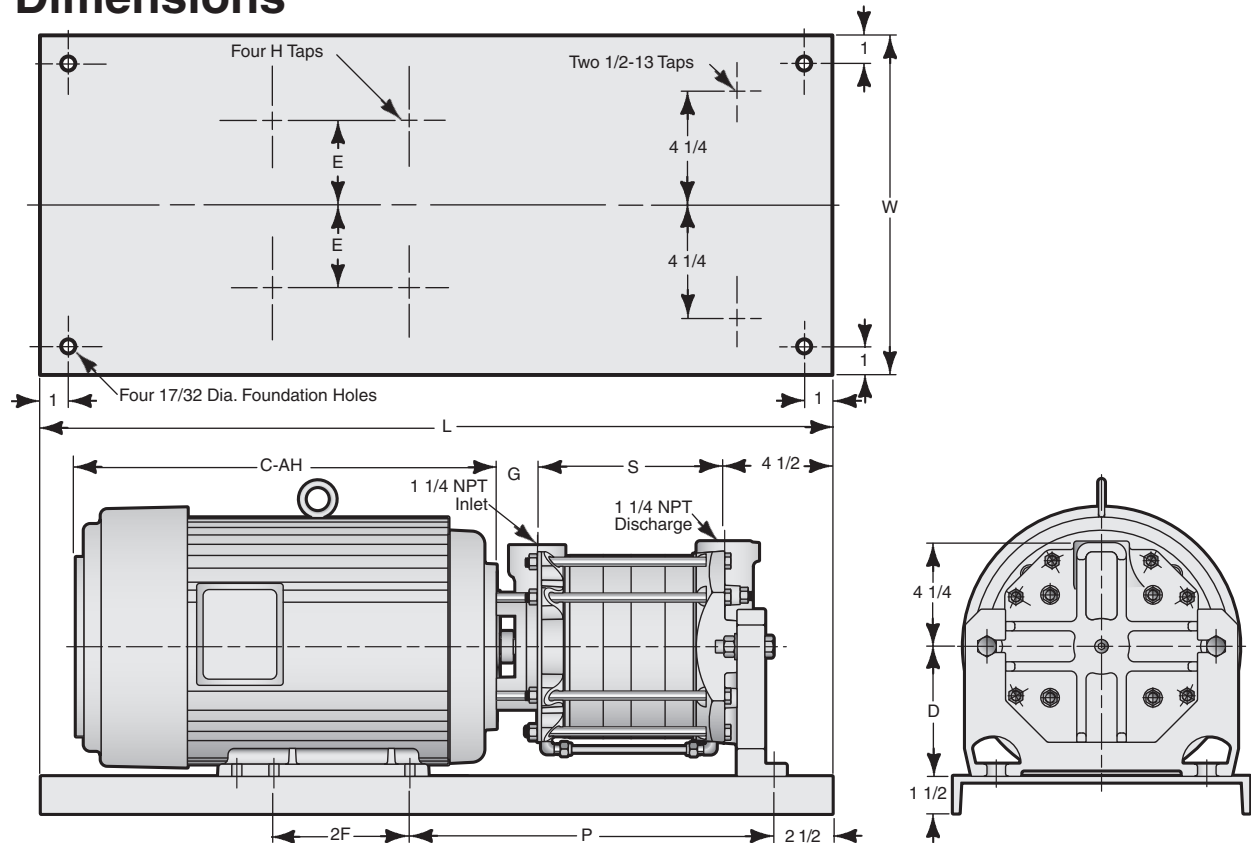

## M50 SERIES BASE MOUNTED CLOSE COUPLED WITH C30 MOTOR (WITHOUT INDUCER)

FRAME	ALL M50 MODELS							MODEL M52			MODEL M53			MODEL M54			MODEL M55		
	C-AH	2F	E	H	G	D	W	S	P	L	S	P	L	S	P	L	S	P	L
184	13 3/4	5 1/2	3 3/4	3/8-16	1 3/16	5 1/4	12	7 1/2	13 1/2	28	10	16	30	12 1/2	18 1/2	32	15	21	35
213	15 1/2	5 1/2	4 1/4	3/8-16	1 3/16	5 1/4	12	7 1/2	14 1/4	32	10	16 3/4	35	12 1/2	19 1/4	40	15	21 3/4	40
215	17	7	4 1/4	3/8-16	1 3/16	5 1/4	12	7 1/2	14 1/4	32	10	16 3/4	35	12 1/2	19 1/4	40	15	21 3/4	40
254	19 3/4	8 1/4	5	1/2-13	1 3/16	6 1/4	15	7 1/2	15	35	10	17 1/2	40	12 1/2	20	40	15	22 1/2	45
256	21 1/2	10	5	1/2-13	1 3/16	6 1/4	15	7 1/2	15	35	10	17 1/2	40	12 1/2	20	40	15	22 1/2	45
284	22	9 1/2	5 1/2	1/2-13	1 3/16	7	15	7 1/2	15 1/2	40	10	18	40	12 1/2	20 1/2	45	15	23	45
286	23 1/2	11	5 1/2	1/2-13	1 3/16	7	15	7 1/2	15 1/2	40	10	18	40	12 1/2	20 1/2	45	15	23	45

## L50 SERIES BASE MOUNTED CLOSE COUPLED WITH C30 MOTOR (WITH INDUCER)

FRAME	ALL L50 MODELS							MODEL L52			MODEL L53			MODEL L54			MODEL L55		
	C-AH	2F	E	H	G	D	W	S	P	L	S	P	L	S	P	L	S	P	L
184	13 3/4	5 1/2	3 3/4	3/8-16	2 1/4	5 1/4	12	8 7/16	15 7/16	30	10 15/16	17 15/16	32	13 7/16	20 7/16	35	15 15/16	22 15/16	40
213	15 1/2	5 1/2	4 1/4	3/8-16	2 1/4	5 1/4	12	8 7/16	16 3/16	35	10 15/16	18 11/16	35	13 7/16	21 3/16	40	15 15/16	23 11/16	40
215	17	7	4 1/4	3/8-16	2 1/4	5 1/4	12	8 7/16	16 3/16	35	10 15/16	18 11/16	35	13 7/16	21 3/16	40	15 15/16	23 11/16	40
254	19 3/4	8 1/4	5	1/2-13	2 1/4	6 1/4	15	8 7/16	16 15/16	40	10 15/16	19 7/16	40	13 7/16	21 15/16	45	15 15/16	24 7/16	45
256	21 1/2	10	5	1/2-13	2 1/4	6 1/4	15	8 7/16	16 15/16	40	10 15/16	19 7/16	40	13 7/16	21 15/16	45	15 15/16	24 7/16	45
284	22	9 1/2	5 1/2	1/2-13	2 1/4	7	15	8 7/16	17 7/16	40	10 15/16	19 15/16	45	13 7/16	22 7/16	45	15 15/16	24 15/16	50
286	23 1/2	11	5 1/2	1/2-13	2 1/4	7	15	8 7/16	17 7/16	40	10 15/16	19 15/16	45	13 7/16	22 7/16	45	15 15/16	24 15/16	50

## NOTES

All dimensions in inches. May vary  $\pm 1/4$  inches.

Not for construction purposes unless certified.

\*See motor price sheet for C-AH dimension (varies depending on motor enclosure)



**MTH PUMPS**

401 West Main Street • Plano, IL 60545-1436

Phone: 630-552-4115 • Fax: 630-552-3688

Email: SALES@MTHPUMPS.COM

http://WWW.MTHPUMPS.COM

M50 • L50 SERIES  
**Dimensions**

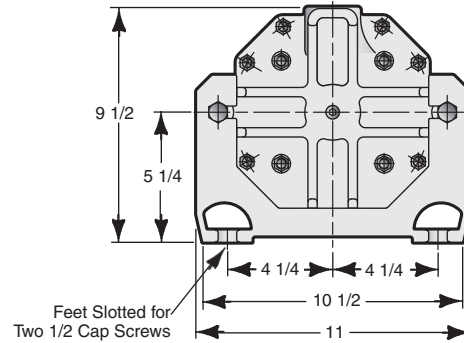
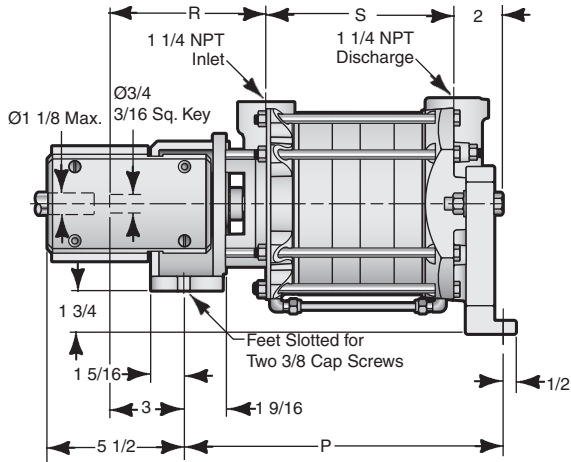

**M50 • L50 SERIES PUMP END ONLY WITH P3 BEARING PEDESTAL**

DIM.	PUMPS WITHOUT INDUCER				PUMPS WITH INDUCER				
	M52	M53	M54	M55	L51	L52	L53	L54	L55
S	7 1/2	10	12 1/2	15	5 15/16	8 7/16	10 15/16	13 7/16	15 15/16
P	12 7/16	14 15/16	17 7/16	19 15/16	11 7/8	14 3/8	16 7/8	19 3/8	21 7/8
R	5 15/16	5 15/16	5 15/16	5 15/16	6 15/16	6 15/16	6 15/16	6 15/16	6 15/16

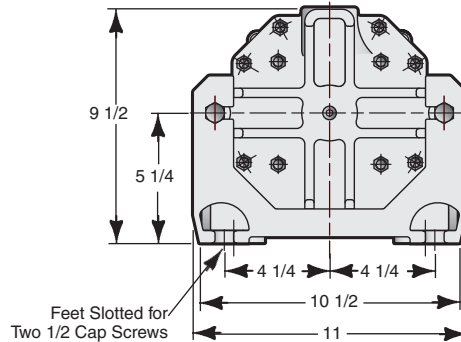
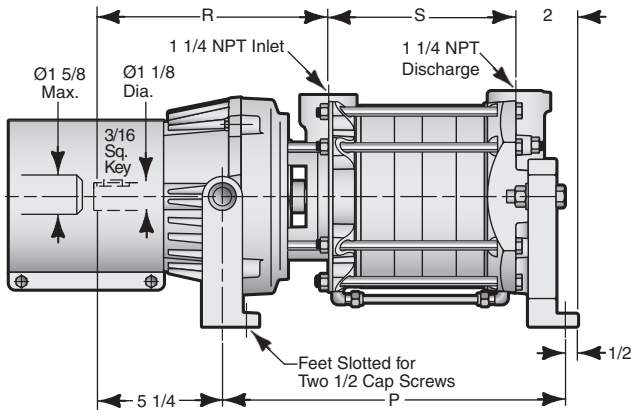

**M50 • L50 SERIES PUMP END ONLY WITH P30 BEARING PEDESTAL**

DIM.	PUMPS WITHOUT INDUCER				PUMPS WITH INDUCER			
	M52	M53	M54	M55	L52	L53	L54	L55
S	7 1/2	10	12 1/2	15	8 7/16	10 15/16	13 7/16	15 15/16
P	13 3/8	15 7/8	18 3/8	20 7/8	15 5/16	17 13/16	20 5/16	22 13/16
R	9 1/16	9 1/16	9 1/16	9 1/16	10 1/8	10 1/8	10 1/8	10 1/8

**NOTES**

All dimensions in inches. May vary ± 1/4 inches.  
 Not for construction purposes unless certified.



**MTH PUMPS**

401 West Main Street • Plano, IL 60545-1436  
 Phone: 630-552-4115 • Fax: 630-552-3688  
 Email: SALES@MTHPUMPS.COM  
 http://WWW.MTHPUMPS.COM

M50 • L50 SERIES PUMPS

# M50 • L50 SERIES

## Dimensions

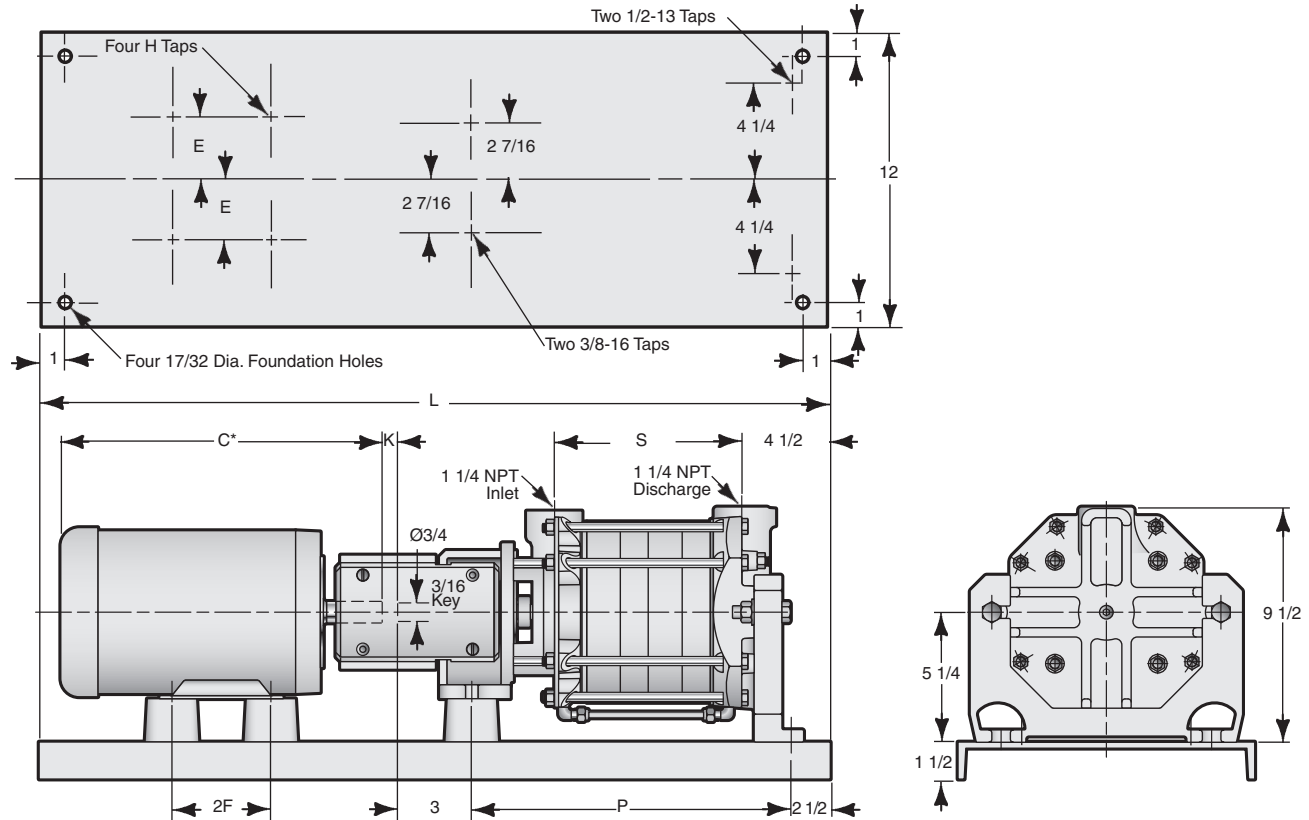

### M50 SERIES BASE MOUNTED ASSEMBLY WITH P3 BEARING FRAME (WITHOUT INDUCER)

FRAME	CPLG	ALL M50 MODELS					MODEL M51			MODEL M52			MODEL M53			MODEL M54			MODEL M55		
		2F	E	H	K		S	P	L	S	P	L	S	P	L	S	P	L	S	P	L
56	3J	3	2 7/16	5/16-18	5/8	REFER TO T51 SERIES	7 1/2	12 7/16	32	10	14 15/16	35	12 1/2	17 7/16	38	15	19 15/16	40			
143T	4J	4	2 3/4	5/16-18	5/8		7 1/2	12 7/16	35	10	14 15/16	35	12 1/2	17 7/16	38	15	19 15/16	40			
145T	4J	5	2 3/4	5/16-18	5/8		7 1/2	12 7/16	35	10	14 15/16	35	12 1/2	17 7/16	38	15	19 15/16	40			
182T	5J	4 1/2	3 3/4	3/8-16	3/4		7 1/2	12 7/16	35	10	14 15/16	38	12 1/2	17 7/16	40	15	19 15/16	45			
184T	5J	5 1/2	3 3/4	3/8-16	3/4		7 1/2	12 7/16	35	10	14 15/16	38	12 1/2	17 7/16	40	15	19 15/16	45			

### L50 SERIES BASE MOUNTED ASSEMBLY WITH P3 BEARING FRAME (WITH INDUCER)

FRAME	CPLG	ALL L50 MODELS					MODEL L51			MODEL L52			MODEL L53			MODEL L54			MODEL L55		
		2F	E	H	K		S	P	L	S	P	L	S	P	L	S	P	L	S	P	L
56	3J	3	2 7/16	5/16-18	5/8	5 15/16	11 7/8	32	8 7/16	14 3/8	35	10 15/16	16 7/8	38	13 7/16	19 3/8	40	15 15/16	21 7/8	45	
143T	4J	4	2 3/4	5/16-18	5/8	5 15/16	11 7/8	32	8 7/16	14 3/8	35	10 15/16	16 7/8	38	13 7/16	19 3/8	40	15 15/16	21 7/8	45	
145T	4J	5	2 3/4	5/16-18	5/8	5 15/16	11 7/8	32	8 7/16	14 3/8	35	10 15/16	16 7/8	38	13 7/16	19 3/8	40	15 15/16	21 7/8	45	
182T	5J	4 1/2	3 3/4	3/8-16	3/4	5 15/16	11 7/8	35	8 7/16	14 3/8	38	10 15/16	16 7/8	40	13 7/16	19 3/8	45	15 15/16	21 7/8	45	
184T	5J	5 1/2	3 3/4	3/8-16	3/4	5 15/16	11 7/8	35	8 7/16	14 3/8	38	10 15/16	16 7/8	40	13 7/16	19 3/8	45	15 15/16	21 7/8	45	

#### NOTES

All dimensions in inches. May vary  $\pm 1/4$  inches.  
Not for construction purposes unless certified.

\*See motor price sheet for C dimension (varies depending on motor enclosure)



# MTH PUMPS

401 West Main Street • Plano, IL 60545-1438  
Phone: 630-552-4115 • Fax: 630-552-3688  
Email: SALES@MTHPUMPS.COM  
http://WWW.MTHPUMPS.COM



M50 • L50 SERIES  
**Dimensions**

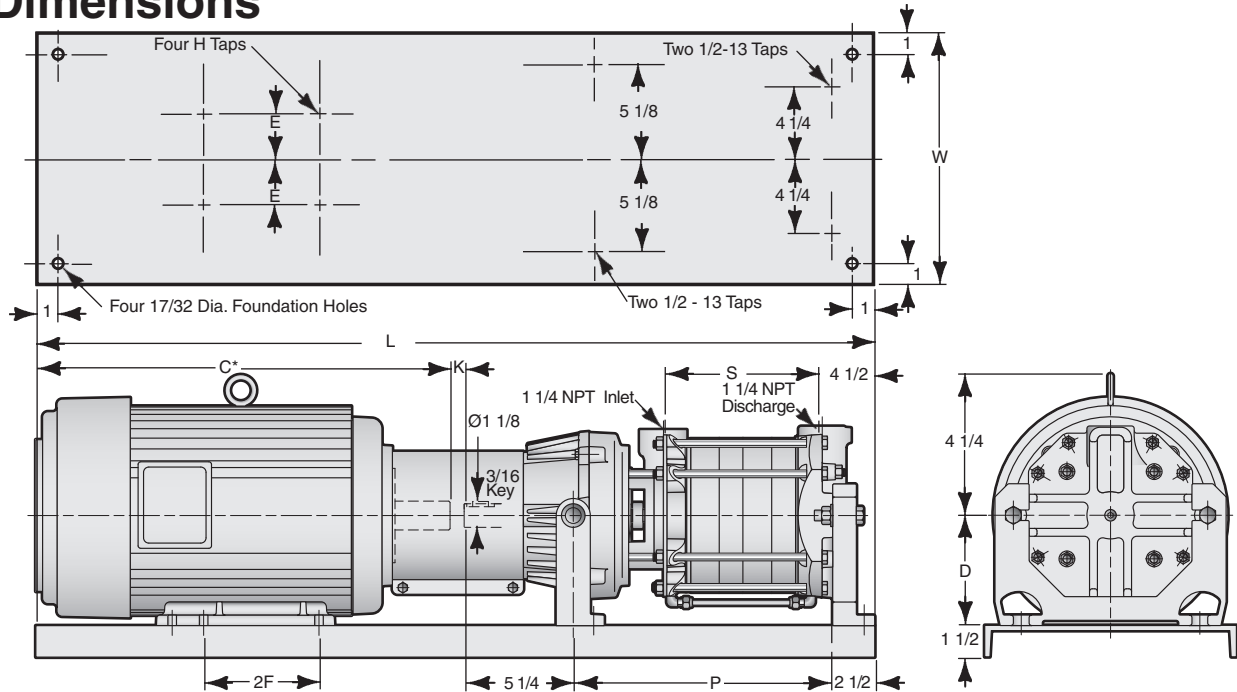

**M50 SERIES BASE MOUNTED ASSEMBLY WITH P30 BEARING FRAME (WITHOUT INDUCER)**

FRAME	ALL M50 MODELS							MODEL M52			MODEL M53			MODEL M54			MODEL M55		
	CPLG	2F	D	W	E	H	K	S	P	L	S	P	L	S	P	L	S	P	L
184T	5J	5 1/2	5 1/4	12	3 3/4	3/8-16	3/4	7 1/2	13 3/8	40	10	15 7/8	45	12 1/2	18 3/8	45	15	20 7/8	50
213T	6J	5 1/2	5 1/4	12	4 1/4	3/8-16	7/8	7 1/2	13 3/8	45	10	15 7/8	45	12 1/2	18 3/8	50	15	20 7/8	50
215T	6J	7	5 1/4	12	4 1/4	3/8-16	7/8	7 1/2	13 3/8	45	10	15 7/8	45	12 1/2	18 3/8	50	15	20 7/8	50
254T	7S	8 1/4	6 1/4	15	5	1/2-13	1	7 1/2	13 3/8	50	10	15 7/8	50	12 1/2	18 3/8	55	15	20 7/8	55
256T	7S	10	6 1/4	15	5	1/2-13	1	7 1/2	13 3/8	50	10	15 7/8	50	12 1/2	18 3/8	55	15	20 7/8	55
284TS	8S	9 1/2	7	15	5 1/2	1/2-13	1 1/8	7 1/2	13 3/8	50	10	15 7/8	55	12 1/2	18 3/8	55	15	20 7/8	60
286TS	8S	11	7	15	5 1/2	1/2-13	1 1/8	7 1/2	13 3/8	50	10	15 7/8	55	12 1/2	18 3/8	55	15	20 7/8	60
324TS	8S	10 1/2	8	18	6 1/4	21/32	1 1/8	7 1/2	13 3/8	50	10	15 7/8	55	12 1/2	18 3/8	55	15	20 7/8	60
326TS	8S	12	8	18	6 1/4	21/32	1 1/8	7 1/2	13 3/8	50	10	15 7/8	55	12 1/2	18 3/8	55	15	20 7/8	60

**L50 SERIES BASE MOUNTED ASSEMBLY WITH P30 BEARING FRAME (WITH INDUCER)**

FRAME	ALL L50 MODELS							MODEL L52			MODEL L53			MODEL L54			MODEL L55				
	CPLG	2F	D	W	E	H	K	S	P	L	S	P	L	S	P	L	S	P	L		
184T	5J	5 1/2	5 1/4	12	3 3/4	3/8-16	3/4	8 7/16	15 5/16	40	10	15 1/16	17 13/16	45	13 7/16	20 5/16	45	15	15 1/16	22 13/16	50
213T	6J	5 1/2	5 1/4	12	4 1/4	3/8-16	7/8	8 7/16	15 5/16	45	10	15 1/16	17 13/16	50	13 7/16	20 5/16	50	15	15 1/16	22 13/16	55
215T	6J	7	5 1/4	12	4 1/4	3/8-16	7/8	8 7/16	15 5/16	45	10	15 1/16	17 13/16	50	13 7/16	20 5/16	50	15	15 1/16	22 13/16	55
254T	7S	8 1/4	6 1/4	15	5	1/2-13	1	8 7/16	15 5/16	50	10	15 1/16	17 13/16	55	13 7/16	20 5/16	55	15	15 1/16	22 13/16	60
256T	7S	10	6 1/4	15	5	1/2-13	1	8 7/16	15 5/16	50	10	15 1/16	17 13/16	55	13 7/16	20 5/16	55	15	15 1/16	22 13/16	60
284TS	8S	9 1/2	7	15	5 1/2	1/2-13	1 1/8	8 7/16	15 5/16	55	10	15 1/16	17 13/16	55	13 7/16	20 5/16	60	15	15 1/16	22 13/16	60
286TS	8S	11	7	15	5 1/2	1/2-13	1 1/8	8 7/16	15 5/16	55	10	15 1/16	17 13/16	55	13 7/16	20 5/16	60	15	15 1/16	22 13/16	60
324TS	8S	10 1/2	8	18	6 1/4	21/32	1 1/8	8 7/16	15 5/16	55	10	15 1/16	17 13/16	55	13 7/16	20 5/16	60	15	15 1/16	22 13/16	60
326TS	8S	12	8	18	6 1/4	21/32	1 1/8	8 7/16	15 5/16	55	10	15 1/16	17 13/16	55	13 7/16	20 5/16	60	15	15 1/16	22 13/16	60

**NOTES**

All dimensions in inches. May vary ± 1/4 inches.  
Not for construction purposes unless certified.  
\*See motor price sheet for C dimension (varies depending on motor enclosure)



**MTH PUMPS**

401 West Main Street • Plano, IL 60545-1436  
Phone: 630-552-4115 • Fax: 630-552-3688  
Email: SALES@MTHPUMPS.COM  
http://WWW.MTHPUMPS.COM