

PERFORATED FILTER SCREEN



The FSM Filter Screen was developed to solve modern day screening problems which occur in wastewater pretreatment. Following a successful test phase, the first system was installed in 1987. Since that time more than 1,500 units have been installed worldwide with over 350 in the USA. The FSM Filter Screen is characterized by its sturdy construction and operational reliability.

FEATURES

- Rugged stainless steel construction
- Completely enclosed
- Screenings positively conveyed to discharge point
- Filter elements optimally cleaned due to precise brush contact
- Insensitive to grit and stones
- Perforated panels resist stapling effect of fibrous material
- Lifting fingers for larger particles
- Patented seal design between panels (optional)

BENEFITS

- High reliability, low maintenance cost
- No need for upstream coarse screening
- Ability to handle high grease discharges without clogging
- Easily adapted to suit modified operating conditions



Water and Wastewater Equipment by: WASTE-TECH HI-TECH



Completely enclosed for odor control and hygienic operation.

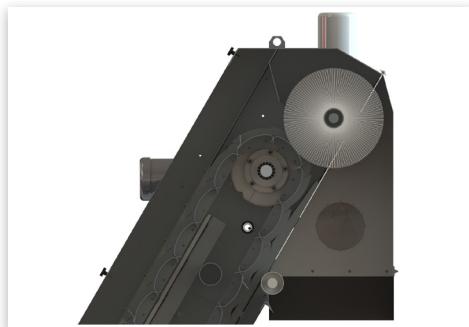

Optimized Brush Configuration for superior cleaning.

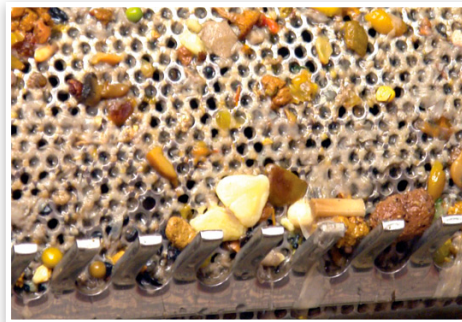

Screen removes up to 60% of fats and floating matter.

OVERVIEW

The FSM Filter Screen eliminates operational disruptions caused by fibrous and other inorganic material. Depending on the perforated panel, the screened material is 3 to 5 times greater compared to a bar screen with an opening of 20 mm. Up to 60% of the floating matter and fats are removed. The quality of the screened effluent is noticeably improved, which in turn improves sludge treatment and has favorable consequences for subsequent agricultural use.

PRINCIPLE OF OPERATION

Wastewater flows through perforated filter elements while contaminants are captured on the face of the element. Larger objects, such as sticks, rocks, bottles, etc, are picked up from the bottom of the channel by the lifting tines at the bottom of every fifth element. The filter panels form a continuous belt which transports the screenings to the discharge point where they are cleaned from the panels by a rotating brush. The screenings are then discharged into a dumpster, conveyor, or compactor.

DIMENSIONS

Channel widths from 1 to 10 feet

Standard channel depths to 36 feet

Filter element perforations of 3, 6, and 10 mm are standard (*other sizes on request*)

Angles of inclination: 50°, 60°, and 75°

MATERIAL

Frame: 304 or 316 stainless steel

Filter Element: 304 or 316 stainless steel

Chain: Wear resistant steel, wear resistant 304 or 316 stainless steel

Sprockets: Wear resistant steel, wear resistant 304 or 316 stainless steel

Side Seals: UHMW plastic

Chain Supports: UHMW plastic

Drives: Shaft mounted helical gear

For more information call **864.576.0660**
or visit **kusterswater.com**



KUSTERS WATER
a division of KUSTERS ZIMA

Water and Wastewater Equipment by: **WASTE-TECH** **HI-TECH**