



PMCB and LSCB Evaporative Condensers

Featuring:

- Exclusive Thermal-Pak® Coil.
- G-235 Galvanized Steel Construction.
- Totally Enclosed Fan and Pump Motors.



Mr. GoodTower™



MEMBER
International
Institute of
Ammonia Refrigeration

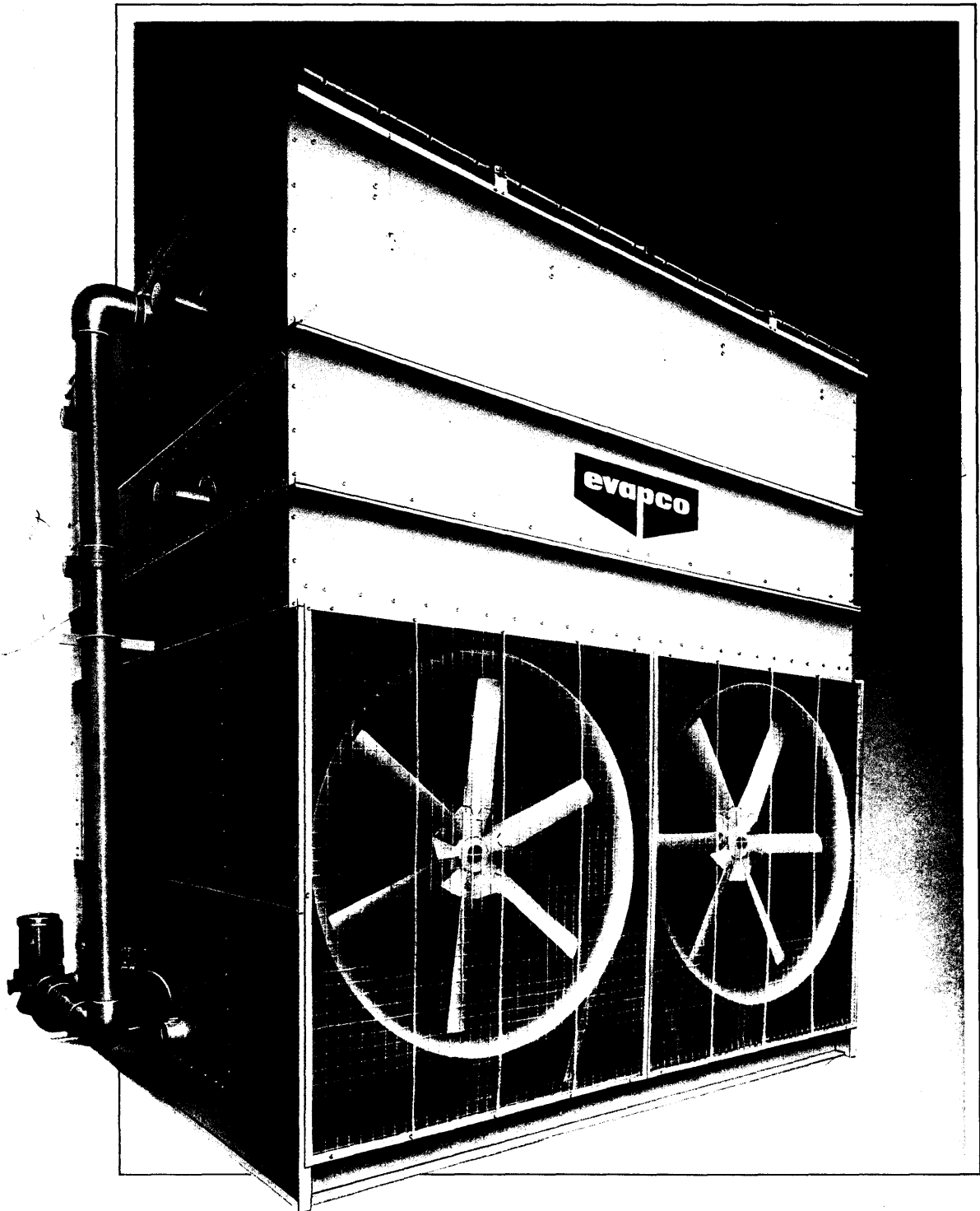

Evaporative Condensers from EVAPCO

EVAPCO manufactures both forced draft and induced draft evaporative condensers. (See Bulletin entitled "ATC Evaporative Condensers" for induced draft models.)

The forced draft, or blow-through models may be of either the vane axial or centrifugal fan designs. Each has its own advantages as described in the following pages.

Lowest in First Cost

An advantage of the Evaporative Condenser is that the initial cost is less than other methods of condensing, such as air cooled or combination cooling tower with separate shell and tube condenser. In addition, their compact design requires less operating space and less supporting steel. Condensers from EVAPCO utilize a modular design with factory assembled construction to ensure lower field installation costs. The total installed costs are, therefore, considerably less than those of other condensing methods.

Lowest in Operating Costs

Evaporative Condensers also provide significantly lower operating costs than other conventional air cooled or water cooled condensing systems. The inherent efficiency of evaporative cooling provides lower condensing temperatures and reduced system horsepower resulting in substantial energy savings. In addition, maintenance costs are minimized through the latest technological advancements in evaporative cooled equipment. These include a simplified water distribution system, PVC drift eliminators, the EVAPCOAT corrosion protection system, two stage vane axial fans and many other equipment features pioneered by EVAPCO.



Power-Mizer Models - PMCB
From 175 to 1770 Nominal Tons
Low Energy Consumption

Centrifugal Fan Models - LSCB
From 36 to 1610 Nominal Tons
Very Quiet Operation



Leader in Design Innovation

Thermal-Pak® Coil Design

Evaporative Condensers by EVAPCO feature the patented Thermal-Pak® coil design which assures greater operating efficiency. The elliptical tube design allows for closer tube spacing, resulting in greater surface area per plan area than round tube designs. In addition, the Thermal-Pak® design has lower resistance to airflow, and also permits greater water loading, making the Thermal-Pak® coil the most effective design available.

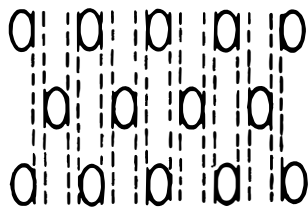

Thermal-Pak® Coil by EVAPCO

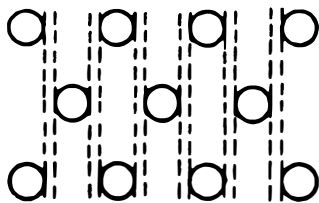

Round Tube Coils by Others

Effective Water Coverage

EVAPCO has led the industry in the design of water distribution systems for evaporative condensers. Innovations include a simplified design with large orifice nozzles and corrosion-free PVC construction as standard equipment.

Corrosion-Resistant Materials

The standard construction of evaporative cooling equipment for many years has been hot-dip galvanized steel. The purpose of galvanizing is to protect the base metal from corrosion, and the thickness of the galvanized layer directly affects the equipment life.

EVAPCO has been instrumental in the development of corrosion protection technology and is the first manufacturer to use **G-235** galvanized steel construction. The **G-235** designation means a minimum of 2.35 ounces of zinc per square foot of surface area. This is an increase of 12% over G-210 galvanized steel, and an increase of 160% over G-90 galvanized steel used by other manufacturers.

Totally Enclosed Motors

EVAPCO is also the first manufacturer to use totally enclosed, fan-cooled (TEFC) motors on all fans and pumps. These superior motors help to assure longer equipment life without motor failures, which may result in costly downtime.

Heavy Duty Construction

EVAPCO condensers are specially designed and built for the rugged conditions under which they must operate. The design incorporates large, heavy-duty panels with double-brake flanges and a minimum of seams to virtually eliminate water leaks. Single brake flanges used in other designs are not as rigid and may permit casing water leaks.

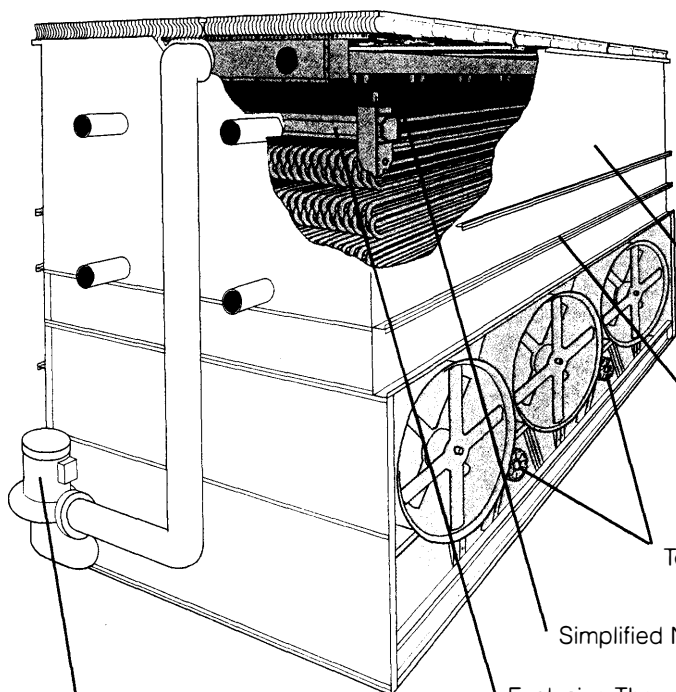

G-235 Galvanized Steel Construction for Superior Corrosion Protection.

Double-Brake Flange Joints for Superior Strength (much stronger than Single-Brake).

Totally Enclosed (TEFC) Fan Motors.

Simplified Non-Clogging Water Distribution System.

Exclusive Thermal-Pak® Coil Providing Maximum Efficiency per Plan Area.

Totally Enclosed Pump Motor.

Quality Construction

Condensing Coil

EVAPCO's patented Thermal-Pak® condensing coils feature a design which assures maximum condensing capacity. The airflow thru the coil is counterflow to the refrigerant flow, providing the most efficient heat transfer process. This special coil design is utilized to reduce the air pressure drop through the unit while maximizing tube surface area and increasing its heat transfer capabilities. The uniquely shaped tubes of the coil are staggered in the direction of air flow to obtain a high film coefficient. In addition, all tubes are pitched in the direction of refrigerant flow to give good drainage of liquid refrigerant.

The coils are manufactured from high quality steel tubing following the most stringent quality control procedures. Each circuit is inspected to assure the material quality and then tested before being assembled into a coil. Finally, the assembled coil is tested at 350 P.S.I.G. air pressure under water to make sure it is leak free.

To protect the coil against corrosion, it is placed in a heavy-duty steel frame and the entire assembly is dipped in molten zinc (hot-dip galvanized) at a temperature of approximately 800°F.

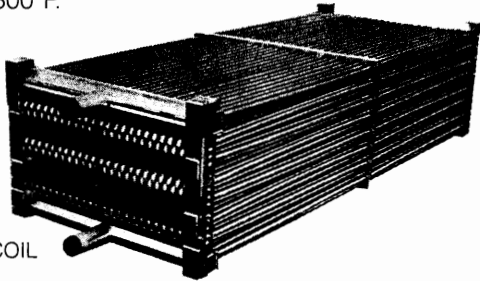

THERMAL-PAK® COIL

Water Distribution System

Another important part of an evaporative condenser is the water distribution system. In order to give the maximum heat transfer and minimize scaling, the coil must be drenched with water at all times. The EVAPCO system does this by circulating approximately 6 gallons of water per minute over every square foot of coil face area.

The water distribution system is greatly simplified in EVAPCO units, with the largest non-clog water diffusers available for evaporative condensers. The diffusers are threaded into the water distribution header to ensure correct positioning. Also, a collar on the diffuser extends into the header and acts as an anti-sludge ring to reduce the need for maintenance. Excellent flooding of the coil is maintained at all times without numerous small orifice nozzles.

For corrosion protection the diffusers are made of ABS plastic and distributor pipes are noncorrosive Polyvinyl Chloride (PVC).



WATER DIFFUSER

PVC Eliminators

The final elements in the upper part of the condenser are moisture eliminators which strip the entrained water droplets from the leaving air stream. EVAPCO's patented* eliminators are approximately 5" deep, spaced on 1" centers. They incorporate a hooked leaving edge designed to direct the discharge air stream away from the fans to help eliminate recirculation of hot, saturated air back into the fan intake.

EVAPCO eliminators are constructed entirely of inert, corrosion-free PVC. This PVC ELIMINATOR material has been specially treated to resist damaging ultraviolet light. The eliminators are assembled in easily handled sections to facilitate removal thereby exposing the upper portion of the unit and water distribution system for periodic inspection.

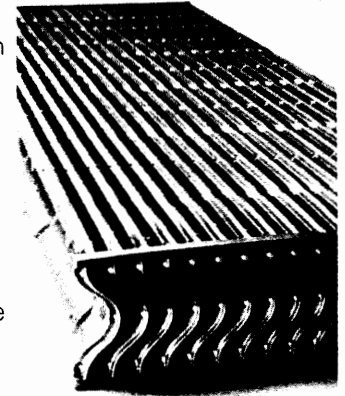

*U.S. Patent No. 4,500,330

Basin Section

EVAPCO basins are large and open, making them easy to clean and service. There is a depressed sump area to catch all foreign matter. The basins are equipped with standard accessories including a close-coupled centrifugal pump with mechanical seal, waste water bleed line, makeup valve with float, and access doors. A **Type 304 Stainless Steel strainer is provided as standard equipment** and is easily removed for periodic cleaning.

EVAPCOAT:

Galvanized Steel Construction

The steel casings and basin are constructed of heavy gauge **G-235** mill hot-dip galvanized steel. The material is coated with 2.35 ounces of zinc per square foot, the heaviest zinc coating available for extended corrosion resistance.

During fabrication, all panel edges are coated with 95% pure zinc-rich compound.

TEFC Motors

All motors on EVAPCO forced draft evaporative condensers are totally enclosed fan cooled (TEFC) to assure long service life.



Owner Advantages

Technology Leader

EVAPCO is committed to providing the highest quality products at the lowest possible cost. In order to achieve this goal, a major program of research and development is on-going. This program has resulted in a number of advancements in evaporative cooling equipment design which provide EVAPCO's many customers with the highest quality equipment, affordably priced. These include accurate thermal ratings, a new more efficient Thermal-Pak® coil design, the EVAPCOAT corrosion protection system, PVC drift eliminators, type 304 stainless steel strainers and simplified water distribution system as standard equipment. EVAPCO is committed to continual product improvements through its extensive research and development program.

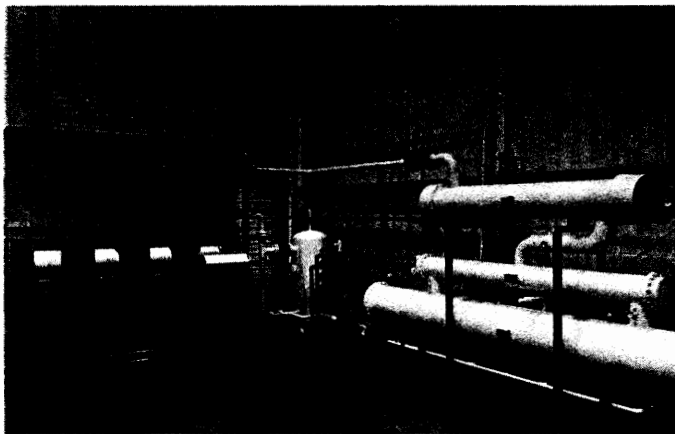

EVAPCO's 20,000 square foot state-of-the-art Research Center located at its Maryland World Headquarters has enabled EVAPCO to remain the industry leader in technology and product innovation. This facility is among the largest of its type in the evaporative cooling industry, and is the most advanced.

With this commitment to constant product improvement and quality, the customer can be assured of obtaining the best product available.

Low Installed Costs

The model LSCB and PMCB evaporative condensers are designed using a modular concept to minimize rigging, piping and support costs. All major components are factory assembled into complete sections. Fans, motors and drives are installed and aligned at the factory as an integral part of the basin section to eliminate the necessity of field rigging these key parts.

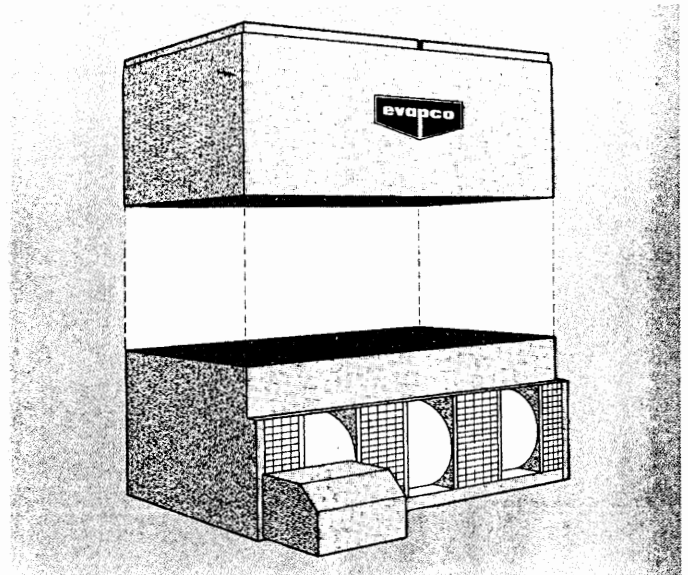

MODULAR INSTALLATION

Quality Assured

Rigid manufacturing standards are implemented throughout the fabrication process. Unit components are fabricated in-house using the latest computer controlled machinery. This ensures that all parts are built to precise standards at the lowest possible cost. The entire manufacturing and assembly process is committed to maintaining a standard of excellence in product quality.

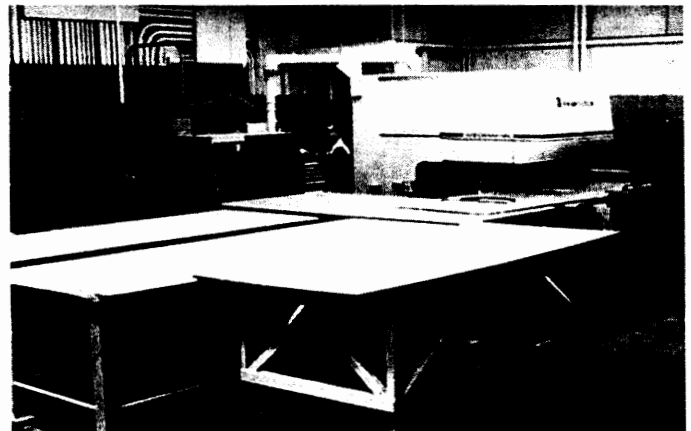

Power-Mizer Models

**Energy Efficient
For Lowest Operating Cost**

PMCB Series

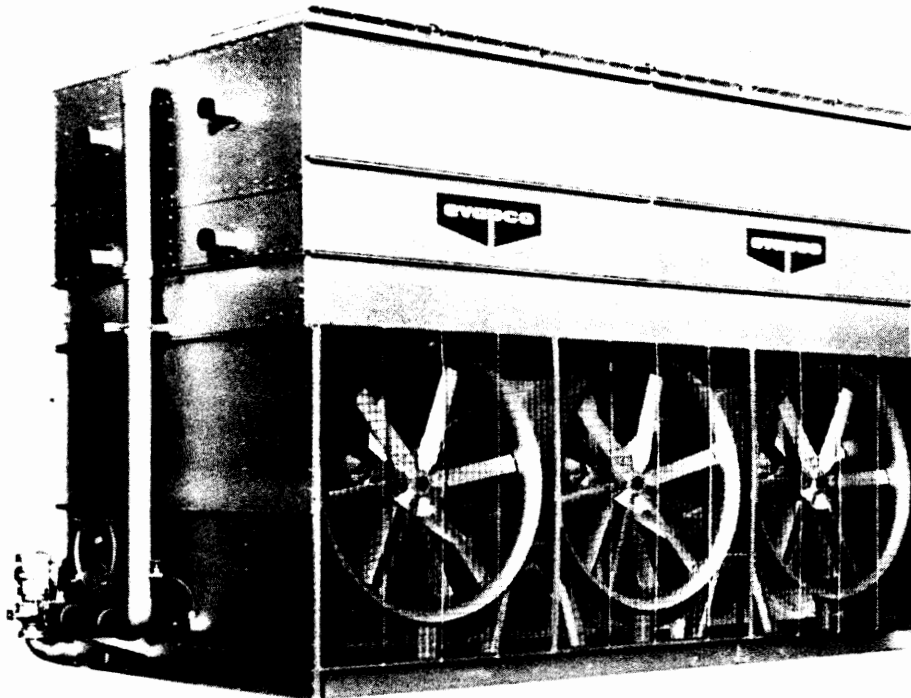

Cuts Operating Horsepower up to 50%

The Power-Mizer models use effective axial flow fans which can reduce power requirements by up to 50%. This results in significant energy savings.

Vane-Axial Fans

In order to obtain high efficiency, a two stage vane-axial fan system is employed. The fans are installed in a closely fitted cowl with a venturi inlet and intermediate guide vanes. This fan design gives the best combination of maximum unit capacity at lowest operating cost. Fans are constructed of heavy duty cast aluminum and are virtually corrosion-free.

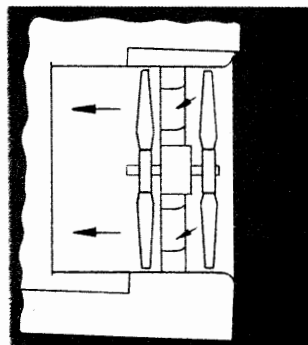

TWO STAGE VANE-AXIAL FAN

Sound Level Consideration

The Power-Mizer condenser models use an efficient airfoil fan that operates at sound levels 8 to 10 decibels above centrifugal fan units. They are normally recommended for commercial and industrial installations.

In noise sensitive situations, the Power-Mizer condenser may be offered with a special wider blade airfoil fan system. The wide blade fan design operates at slower tip speeds with significant sound level reduction. This fan design permits the user to take advantage of substantial energy savings without excessive noise. Consult the factory for wide blade condenser specifications and sound information.

Accessibility

The fan section is completely open and accessible at waist level where each part may be carefully checked by simply removing the safety screens. Bearing grease fittings are extended to the outside of the unit for ease of lubrication.

The basin is also open and easy to access for inspection or cleaning. There is a depressed sump area to catch the dirt accumulated and it may be easily flushed out with a hose through the access door on either end.

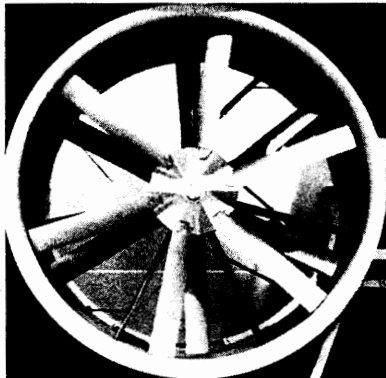

VANE-AXIAL FAN

Power-Band Drive

The Power-Band drive is a solid backed belt system that has high lateral rigidity. This eliminates the problem of mismatched belts and prevents belts from jumping sheaves, a common problem with other designs.

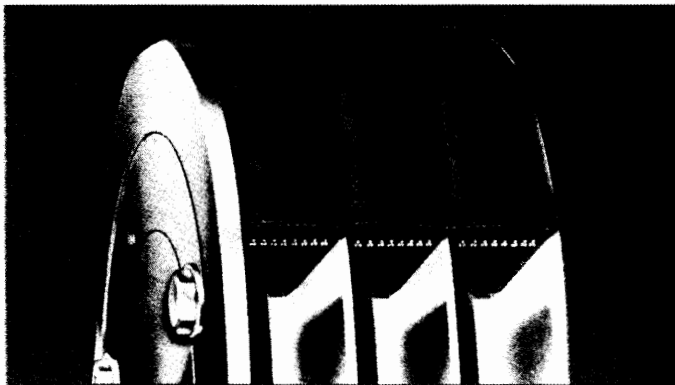

POWER-BAND

Capacity Control

FAN CYCLING VERSATILITY

Industrial refrigeration applications often utilize fan cycling to more closely match the condenser capacity to the system off-peak load. All condenser models from EVAPCO allow each fan motor to be cycled on and off independently.

Units with multiple motors feature an internal baffle system which extends from the pan bottom vertically through the coil bundle. This system prevents the harmful effects of air bypass within the unit when the motor is cycled off.

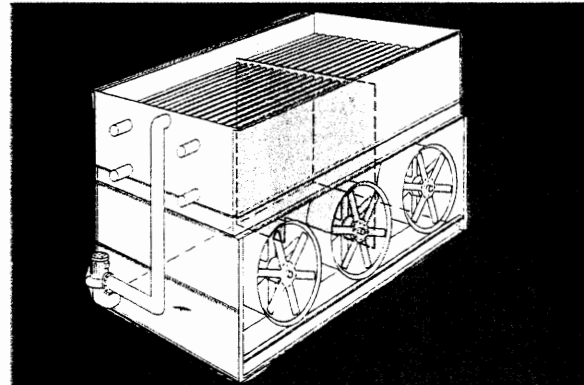

INTERNAL BAFFLE SYSTEM

TWO SPEED MOTORS

For those installations requiring close control, two speed 1800/900 RPM motors are an excellent method of capacity control. Two speed motors are available for the Power-Mizer as well as the centrifugal fan units. This arrangement gives capacity steps of 10% (fans off), 60% (fans half speed) and 100%. These control steps will in most cases allow the performance level of the condenser to closely match the system off-peak load.

A two-stage pressure controller can be supplied to set control steps with a five pound pressure differential. Head pressure cycling may then be closely maintained without excessive cycling of the fan motors.

Two-speed motors also save on operating costs. At half-speed, the motor draws less than 15% of full load power. Since maximum wet bulb and maximum load very seldom coincide, the condenser will actually operate at half-speed as much as 80% of the year. Thus, power costs will be reduced by approximately 85% during the major portion of the operating season.

A third advantage of two-speed motors is that noise levels are reduced by 6 to 8 dB when operating at half-speed. Since both the load and the wet bulb are normally lower at night, the unit will operate at half-speed and the noise level will be substantially reduced during this noise sensitive period.

On multiple cell units, the fan motors may be cycled on and off at different pressures for capacity control, or, fan cycling may be combined with two-speed motors for more steps of control and greater power savings. This arrangement is simple, trouble-free and an inexpensive method of capacity control.

Variable Frequency Drives

Further Capacity control is available through the use of variable frequency drives (VFD's). In response to changing wet bulb and load conditions, the air flow through the unit may be modulated by changing the fan speed so that the capacity of the unit may match the system load.

Centrifugal Fan Models

LSCB Series

Application Versatility

Centrifugal units are recommended for a wide range of installations. They are quiet, can be easily hidden, and the increase in fan motor H.P. over propeller fan units is generally not significant in the small size range. They are also excellent for larger installations where very quiet operation is a must, such as residential neighborhoods.

In addition, centrifugal fan units can operate against the static pressure loss of ductwork and are therefore ideal for indoor installations.

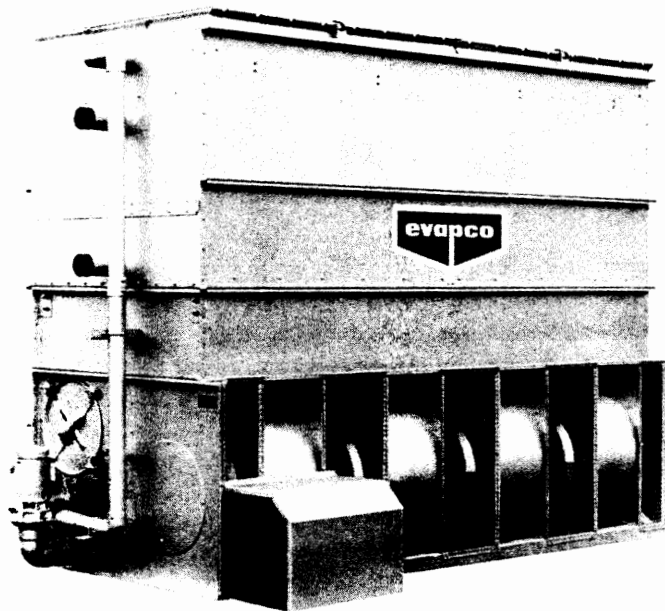

Very Quiet Operation

Centrifugal fan units operate at lower sound levels which make this design preferred for installations where noise is a concern. The sound they produce is primarily at high frequencies which is easily attenuated by building walls, windows, and natural barriers. Additionally, since the sound from the fans is directional, single sided air entry models can be turned away from critical areas avoiding a sound problem. When even quieter operation is necessary, centrifugal fan models can be equipped with optional sound attenuation packages. Consult the factory for details.

For Very Quiet Operation For Indoor Location

Indoor Installation

Centrifugal units may be installed indoors where it is desirable to hide the unit or where this is the only space available. In addition to being quiet, they can handle the external static pressure of ductwork.

The units are designed to be easily connected to ductwork. Drawings are available from the factory which show how to make these ductwork connections.

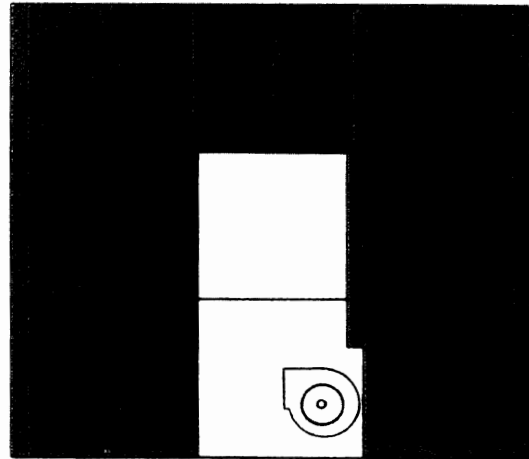

DUCTWORK

Capacity Control Fan Dampers

In addition to the capacity control methods outlined on the previous page, an additional feature of the centrifugal fan unit is the availability of capacity control dampers. These dampers are located directly in the fan housings. They control head pressure by modulating air flow through the unit to match the capacity of the evaporative condenser to the load. When the dampers approach their closed position, an end switch shuts off the fan motor. Dampers are recommended when close control of head pressure is necessary and there is a rapidly fluctuating load. The disadvantage with capacity control dampers is the linkages, motor operators and controllers that are required to operate them. As with all mechanical devices, they need regular maintenance. Damper maintenance is often overlooked, and operational problems may result. In most industrial refrigeration applications, two-speed motors are the capacity control.

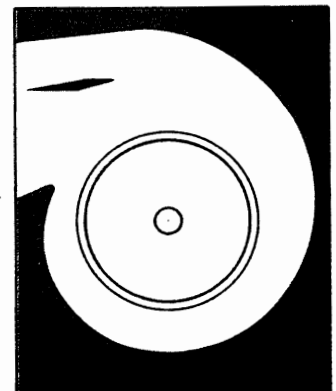

DAMPER

Accessibility

The basin/fan section of a centrifugal fan unit is designed for accessibility and ease of maintenance. Fan and drive components are positioned to allow easy adjustment and cleaning. All grease fittings are in convenient locations for periodic lubrication.

Large circular access doors are provided on each section to allow entry into the basin. All float valve and strainer assemblies are located near the door for easy adjustment and cleaning. The basin sump is designed to catch the dirt accumulated and can be flushed out simply with a hose. The stainless steel strainers may be easily removed for periodic cleaning.



BASIN SECTION ACCESSIBILITY

Centrifugal Fan Assembly

Fans on the LSCB models are of the forward curved centrifugal type with hot-dip galvanized steel construction. All fans are statically and dynamically balanced and are mounted in a hot-dip galvanized steel housing designed and manufactured by EVAPCO.

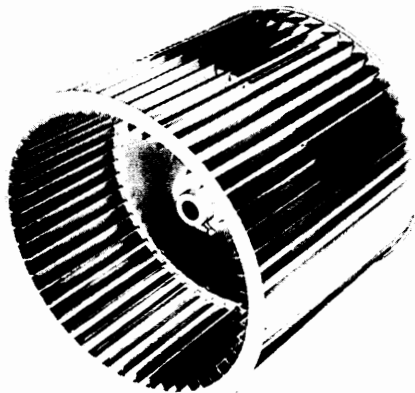

CENTRIFUGAL WHEEL

Fan Motor Mount

Fan motors are mounted in a convenient open area to make it easy to adjust belt tension, lubricate the motor, electrically connect it, or change the motor if necessary. The fan motor and drive are under a protective cover for safety and to protect them from the elements.

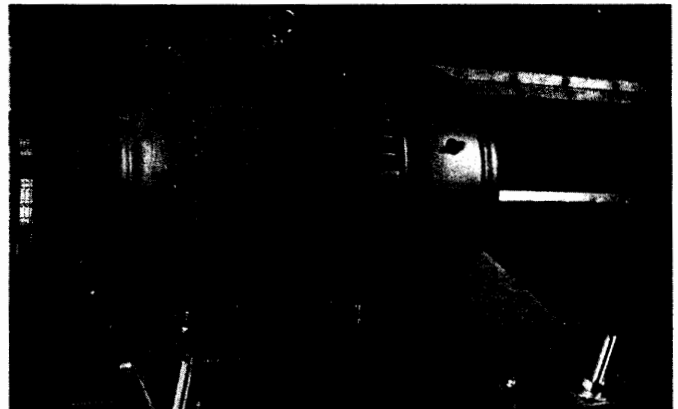

LARGE SERIES MOTOR MOUNT

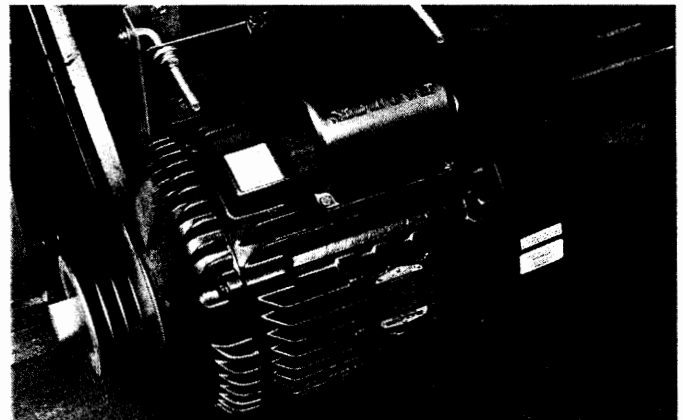

SMALL SERIES MOTOR MOUNT

Selection Procedure

Two methods of selection are presented, the first and simplest is based on evaporator tons as described immediately below. This is only applicable to systems with open type reciprocating compressors.

The second method of selection is by heat of rejection which is described on pages 12 and 13. It is applicable to all but centrifugal compressor applications and is normally used for selecting evaporative condensers for use with hermetic compressors and screw compressors. It can also be used for standard open type reciprocating compressor systems as an alternate to the evaporator ton method below.

The evaporator ton selection method is based on estimated heat of compression. **The heat of rejection method of selection is more accurate and should be used whenever possible.**

Refer to the factory for selections on systems employing centrifugal compressors.

Evaporator Ton Method

The condenser model number in Table 1 is equal to the unit capacity in evaporator tons for standard HCFC-22 or HFC-134a conditions of 105°F condensing, 40°F suction and 78°F wet bulb.

For other conditions, or for ammonia, (R-717) refrigerant, obtain the capacity factors from either Table 2 or Table 3 and multiply times the evaporator load in tons to determine the corrected tons required. Select a model number from Table 1 equal to or larger than the resultant figure.

EXAMPLE

Given: 300 ton evaporator load, R-717 condensing at 95°F with 10°F suction and 76°F wet bulb temperature.

Selection: The capacity factor from Table 3 for R-717 at 95°F and 76°F wet bulb is 1.40, and the capacity factor for 10°F suction is 1.03.

$300 \text{ tons} \times 1.40 \times 1.03 = 433 \text{ Corrected Tons}$. Therefore, select either PMCB-435, PMCB-450, or LSCB-450 depending on horsepower or layout considerations.

* Alternate Power-Mizer models represent selections for alternate plan area or low horsepower applications. Standard models should be used for lowest first-cost selection.

Evaporator Ton Method

TABLE 1 - Unit Sizes

Power-Mizer Models		
PMCB-190	PMCB-480	PMCB-1000
210	510	1015
220	535	1030
235	560	1080
240	580	1120
250	600	1175
275	630	1260
295	660	1320
325	690	1380
350	725	1410
360	755	1485
375	775	1540
390	815	1630
415	855	1710
435	885	1770
455	960	
Alternate Power-Mizer Models*		
PMCB-175	PMCB-475	PMCB-805
290	495	850
330	540	910
335	585	950
385	645	1060
425	705	1110
450	770	1510
		1550
Centrifugal Fan Models		
LSCB-36	LSCB-225	LSCB-650
41	240	690
48	250	720
54	280	755
65	300	800
70	315	805
75	335	860
80	355	900
90	370	960
100	385	1000
110	400	1030
120	430	1100
135	450	1180
150	480	1250
155	500	1308
170	515	1380
185	550	1440
200	590	1510
210	625	1610



TABLE 2 - HCFC-22 and HFC-134a Capacity Factors

Condensing Pres. psig		Cond. Temp. °F.	WET BULB TEMPERATURE, °F.																	
HCFC-22	HFC-134a		50	55	60	62	64	66	68	70	72	74	75	76	77	78	80	82	84	86
156	95	85	1.05	1.16	1.32	1.43	1.53	1.66	1.83	2.02	2.30	2.64	2.87	3.13	3.46	3.80	—	—	—	—
168	104	90	.90	.98	1.10	1.17	1.24	1.31	1.40	1.52	1.65	1.82	1.93	2.05	2.17	2.30	2.75	3.38	—	—
182	114	95	.78	.85	.93	.98	1.02	1.07	1.12	1.19	1.28	1.37	1.42	1.46	1.52	1.60	1.78	2.02	2.31	2.70
196	124	100	.70	.75	.81	.84	.87	.90	.93	.97	1.02	1.08	1.11	1.14	1.19	1.23	1.33	1.44	1.61	1.80
211	135	105	.63	.66	.70	.72	.75	.77	.80	.83	.87	.91	.93	.95	.97	1.00	1.06	1.13	1.23	1.35
226	146	110	.57	.60	.63	.65	.66	.68	.70	.72	.75	.78	.79	.81	.83	.85	.89	.94	.99	1.05

Suction Temp. °F		-20°	-10°	0°	+10°	+20°	+30°	+40°	+50°
Suction Press. (psig)	HCFC-22	10.1	16.5	24.0	32.8	43.0	54.9	68.5	84.0
	HFC-134a	-1.8	1.9	6.5	11.9	18.4	26.1	35.0	45.4
Capacity Factor		1.22	1.17	1.13	1.09	1.06	1.03	1.00	0.97

TABLE 3 - Ammonia (R-717) Capacity Factors

Condensing Pres. psig		Cond. Temp. °F.	WET BULB TEMPERATURE, °F.																
50	55		60	62	64	66	68	70	72	74	75	76	77	78	80	82	84	86	
152	85	.99	1.09	1.25	1.34	1.44	1.57	1.73	1.91	2.17	2.49	2.71	2.95	3.26	3.59	—	—	—	—
166	90	.84	.93	1.03	1.10	1.16	1.23	1.32	1.42	1.55	1.71	1.81	1.92	2.04	2.16	2.59	3.17	—	—
181	95	.74	.80	.87	.92	.97	1.01	1.06	1.12	1.21	1.29	1.33	1.38	1.44	1.51	1.68	1.91	2.18	2.55
185	96.3	.72	.78	.85	.89	.93	.97	1.01	1.07	1.14	1.22	1.26	1.30	1.35	1.41	1.56	1.76	2.01	2.33
197	100	.66	.71	.76	.79	.82	.85	.87	.91	.96	1.01	1.04	1.07	1.12	1.15	1.25	1.36	1.52	1.69
214	105	.59	.62	.66	.68	.71	.73	.75	.78	.82	.86	.88	.90	.91	.94	1.00	1.07	1.16	1.27
232	110	.53	.56	.59	.61	.62	.64	.66	.68	.71	.73	.74	.76	.78	.80	.84	.89	.93	.99

Suction Temp. °F		-30°	-20°	-10°	0°	+10°	+20°	+30°	+40°
Suction Press. (psig)		-1.6	3.6	9.0	15.7	23.8	33.5	45.0	58.6
Capacity Factor		1.18	1.14	1.10	1.07	1.03	1.00	0.97	0.95

NOTE: Table 1 presents only the current standard model line selections. Other models exist for special horsepower or layout applications. Please consult the factory or your EVAPCO representative for these special situations.

Selection Procedure

Heat of Rejection Method

The heat of rejection selection method is similar to the evaporator ton method in that once the heat of rejection is known, the factor for the specified operating conditions (condensing temperature and wet bulb temperature) is obtained from Table 5 or 6 and multiplied times the heat rejection. The resultant figure is used to select a unit from Table 4. Unit Capacities are given in Table 4 in thousands of BTU/Hr or MBH.

If the heat of rejection is not known it can be determined by one of the following formulas:

Open Compressors

$$\text{Heat of Rejection} = \text{Evaporator Load (BTU/Hr)} + \text{Compressor BHP} \times 2545$$

Hermetic Compressors

$$\text{Heat of Rejection} = \text{Evaporator Load (BTU/Hr)} + \text{K.W. Compressor Input} \times 3415$$

EXAMPLE

Given: 270 ton load, ammonia refrigerant 96.3° condensing temperature, 78° W.B. temperature and 300 compressor BHP

Selection: Heat of Rejection
 $270 \text{ tons} \times 12000 = 3,240,000 \text{ BTU/Hr}$
 $300 \text{ BHP} \times 2545 = 763,500 \text{ BTU/Hr}$

Total 4,003,500 BTU/Hr

From Table 6 the capacity factor for 96.3° condensing and 78° W.B. = 1.37 $4,003,500 \times 1.37 = 5,484,795 \text{ BTU/Hr}$ or 5485 MBH.

Therefore, select PMCB-375, PMCB-385 or LSCB-385 depending upon layout, horsepower, and any other design considerations.

Note:

For screw compressor selections employing water cooled oil cooling, select a condenser for the total BTU/Hr as in the example. The condenser can then function in one of two ways:

- (1) Recirculating water from the water sump can be used directly in the oil cooler. A separate pump should be employed and the return water should be directed into the water sump at the opposite end from the pump suction.
- (2) The condenser coil can be circuited so that water or a glycol-water mixture for the oil cooler can be cooled in a separate section of the coil. Specify load and water flow required.

For refrigerant injection cooled screw compressors select the condenser in the same manner as shown in the example.

If the oil cooler is supplied by water from a separate source, then the oil cooling load should be deducted from the heat of rejection before making the selection.

TABLE 4 - Unit Heat Rejection Capacity

Power-Mizer Models					
Model No.	MBH Base	Model No.	MBH Base	Model No.	MBH Base
PMCB-190	2,793	PMCB-455	6,689	PMCB-960	14,112
210	3,087	480	7,056	1000	14,700
220	3,234	510	7,497	1015	14,921
235	3,455	535	7,865	1030	15,141
240	3,528	560	8,232	1080	15,876
250	3,675	580	8,526	1120	16,464
275	4,043	600	8,820	1175	17,273
295	4,337	630	9,261	1260	18,522
325	4,778	660	9,702	1320	19,404
350	5,145	690	10,143	1380	20,286
360	5,292	725	10,658	1410	20,727
375	5,513	755	11,099	1485	21,830
390	5,733	775	11,393	1540	22,638
415	6,101	815	11,981	1630	23,961
435	6,395	855	12,569	1710	25,137
		885	13,010	1770	26,019
Alternate Power-Mizer Models*					
PMCB-175	2,573	PMCB-475	6,983	PMCB-805	11,834
290	4,263	495	7,277	850	12,495
330	4,851	540	7,938	910	13,377
335	4,925	585	8,600	950	13,965
385	5,660	645	9,482	1060	15,582
425	6,248	705	10,364	1110	16,317
450	6,615	770	11,319	1510	22,197
				1550	22,785

* Alternate Power-Mizer models represent selections for alternate plan area or low horsepower applications. Standard models should be used for the lowest first-cost selection.

Centrifugal Fan Models			
Model No.	MBH Base	Model No.	MBH Base
LSCB-36	529	LSCB-400	5,880
41	603	430	6,321
48	706	450	6,615
54	794	480	7,056
65	956	500	7,350
70	1,029	515	7,571
75	1,103	550	8,085
80	1,176	590	8,673
90	1,323	625	9,188
100	1,470	650	9,555
110	1,617	690	10,143
120	1,764	720	10,584
135	1,985	755	11,099
150	2,205	800	11,760
155	2,279	805	11,834
170	2,499	860	12,642
185	2,720	900	13,230
200	2,940	960	14,112
210	3,087	1000	14,700
225	3,308	1030	15,141
240	3,528	1100	16,170
250	3,675	1180	17,346
280	4,118	1250	18,375
300	4,410	1310	19,257
315	4,631	1380	20,286
335	4,925	1440	21,168
355	5,219	1510	22,197
370	5,439	1610	23,667
385	5,660		



TABLE 5 - HCFC-22 and HFC-134a Heat Rejection Factors

Condensing Pres. psig		Cond. Temp. °F.	WET BULB TEMPERATURE, °F.																	
HCFC-22	HFC-134a		50	55	60	62	64	66	68	70	72	74	75	76	77	78	80	82	84	86
156	95	85	1.10	1.22	1.39	1.50	1.61	1.75	1.93	2.13	2.42	2.78	3.02	3.29	3.64	4.00	—	—	—	—
168	104	90	.93	1.02	1.14	1.21	1.28	1.36	1.45	1.57	1.71	1.89	2.00	2.12	2.25	2.38	2.85	3.50	—	—
182	114	95	.80	.87	.95	1.00	1.05	1.10	1.15	1.22	1.31	1.40	1.45	1.50	1.56	1.64	1.82	2.07	2.37	2.77
196	124	100	.71	.76	.82	.85	.88	.91	.94	.98	1.03	1.09	1.12	1.15	1.20	1.24	1.34	1.46	1.63	1.82
211	135	105	.63	.66	.70	.72	.75	.77	.80	.83	.87	.91	.93	.95	.97	1.00	1.06	1.13	1.23	1.35
226	146	110	.56	.59	.62	.64	.65	.67	.69	.71	.74	.77	.78	.80	.82	.84	.88	.93	.98	1.04

TABLE 6 - Ammonia (R-717) Heat Rejection Factors

Condensing Pres. psig		Cond. Temp. °F.	WET BULB TEMPERATURE, °F.																	
			50	55	60	62	64	66	68	70	72	74	75	76	77	78	80	82	84	86
152		85	.98	1.09	1.24	1.34	1.44	1.56	1.72	1.90	2.16	2.48	2.70	2.94	3.25	3.57	—	—	—	—
166		90	.83	.91	1.02	1.08	1.14	1.21	1.29	1.40	1.53	1.69	1.79	1.89	2.01	2.12	2.54	3.12	—	—
181		95	.71	.78	.85	.89	.94	.98	1.03	1.09	1.17	1.25	1.29	1.34	1.39	1.47	1.63	1.85	2.12	2.47
185		96.3	.69	.75	.82	.86	.90	.94	.98	1.03	1.10	1.18	1.22	1.26	1.31	1.37	1.51	1.71	1.94	2.25
197		100	.63	.68	.73	.76	.79	.81	.84	.87	.92	.97	1.00	1.03	1.07	1.11	1.20	1.30	1.46	1.63
214		105	.56	.59	.62	.64	.67	.69	.71	.74	.78	.81	.83	.85	.87	.89	.95	1.01	1.10	1.21
232		110	.50	.53	.55	.57	.58	.60	.62	.63	.66	.69	.70	.71	.73	.75	.79	.83	.87	.93

NOTE: Table 4 presents only the current standard model line selections. Other models exist for special horsepower or layout applications. Please consult the factory or your EVAPCO representative for these special situations.

Engineering Dimensions & Data

Power Mizer Models
PMCB-175 to 375

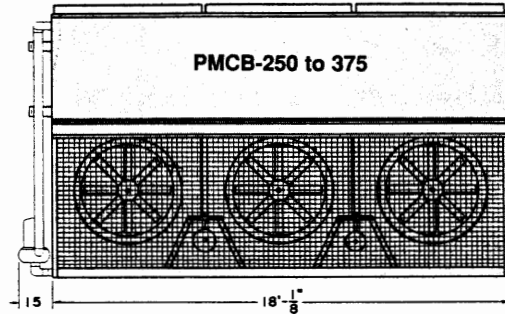
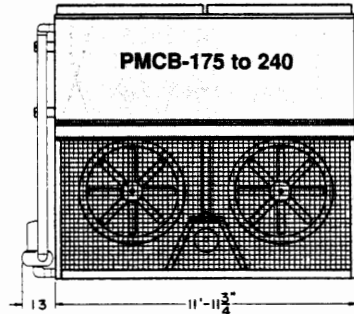
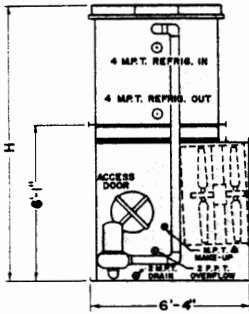

▲ NOTE: MAKE-UP 1" M.P.T. ON
PMCB-175 to PMCB-240
MAKE-UP 1 1/2" M.P.T. ON
PMCB-250 to PMCB-375

TABLE 7 - Engineering Data

UNIT NO.*	R-717 Tons*	FANS		WEIGHTS			R-717 Operating Charge	SPRAY PUMP		REMOTE SUMP		HEIGHT
		HP	CFM	Shipping	Operating	Heaviest Section		HP	GPM	Gallons Req'd**	Conn. Size	
PMCB-175	124	7 1/2	31,300	7,850	10,120	5,470	220	2	345	240	8"	10' 9 1/4"
190	135	10	34,000	7,980	10,250	5,470	220	2	345	240	8"	10' 9 1/4"
210	149	10	33,500	9,090	11,420	6,580	275	2	345	240	8"	11' 5 3/4"
220	156	10	33,000	10,110	12,490	7,700	330	2	345	240	8"	12' 2 1/4"
235	167	15	36,600	9,220	11,550	6,580	275	2	345	240	8"	11' 5 3/4"
240	170	15	35,500	10,240	12,620	7,700	330	2	345	240	8"	12' 2 1/4"
PMCB-250	177	10 & 5	54,000	10,480	13,330	6,690	245	3	515	350	10"	10' 3/4"
275	195	7 1/2 & 5	48,500	12,030	14,970	8,330	330	3	515	350	10"	10' 9 1/4"
295	209	10 & 5	51,900	12,120	15,060	8,330	330	3	515	350	10"	10' 9 1/4"
325	230	10 & 5	50,900	13,830	16,860	9,990	410	3	515	350	10"	11' 5 3/4"
335	238	10 & 5	50,300	15,390	18,520	11,660	495	3	515	350	10"	12' 2 1/4"
360	255	15 & 7 1/2	57,000	14,040	17,070	9,990	410	3	515	350	10"	11' 5 3/4"
375	266	15 & 7 1/2	56,300	15,600	18,730	11,660	495	3	515	350	10"	12' 2 1/4"

* Tons at standard conditions: HCFC-22 and HFC-134a. 105° condensing, 40° suction and 78° W.B.; ammonia 96.3° condensing, 20° suction and 78° W.B.

** Gallons shown is water in suspension in unit and piping. Allow for additional water in bottom of remote sump to cover pump suction and strainer during operation. (12" would normally be sufficient.)



Power Miser Models
PMCB-290 to 1550

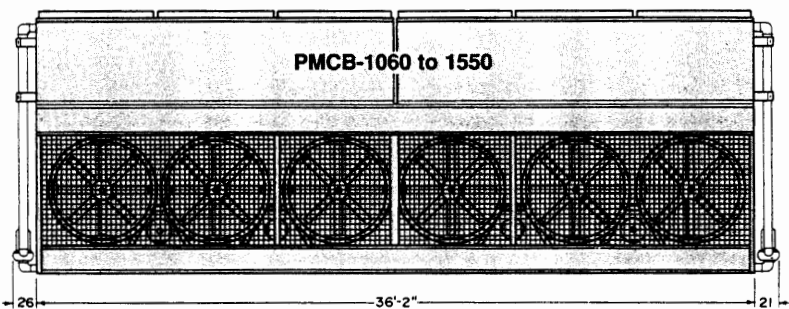
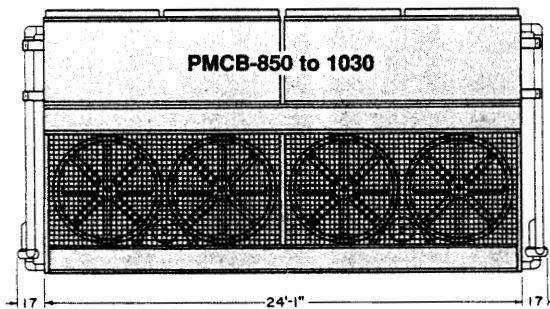
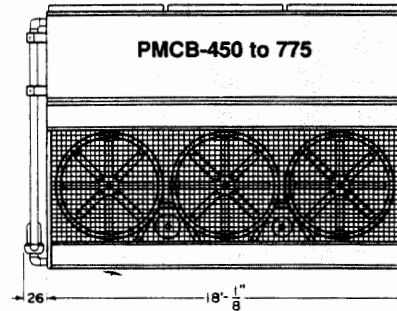
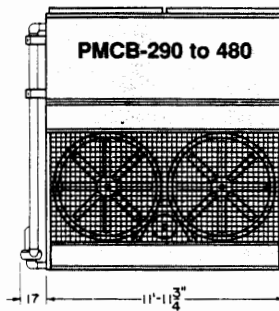
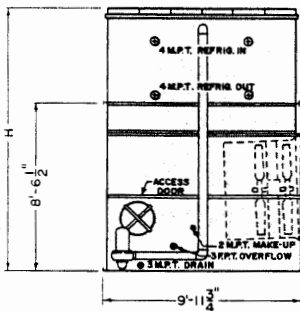

TABLE 8 - Engineering Data

UNIT NO.*	R-717 Tons*	FANS		WEIGHTS			R-717 Operating Charge	SPRAY PUMP		REMOTE SUMP		HEIGHT
		HP	CFM	Shipping	Operating	Heaviest Section		HP	GPM	Gallons Req'd**	Conn. Size	
PMCB- 290	206	10	62,300	12,870	18,530	8,530	330	5	685	420	10"	12' 6 1/4"
330	234	7 1/2	56,500	14,890	20,740	10,740	440	5	685	420	10"	13' 2 3/4"
350	248	10	61,600	14,980	20,830	10,740	440	5	685	420	10"	13' 2 3/4"
385	273	10	60,400	17,090	23,170	12,940	550	5	685	420	10"	13' 11 1/4"
390	277	15	67,800	15,130	20,980	10,740	440	5	685	420	10"	13' 2 3/4"
415	294	20	74,000	15,250	21,100	10,740	440	5	685	420	10"	13' 2 3/4"
425	301	15	66,100	17,240	23,320	12,940	550	5	685	420	10"	13' 11 1/4"
455	323	20	72,500	17,360	23,440	12,940	550	5	685	420	10"	13' 11 1/4"
480	340	25	76,500	17,500	23,580	12,940	550	5	685	420	10"	13' 11 1/4"
PMCB- 450	319	10 & 5	96,500	19,030	27,180	12,380	490	7 1/2	1,030	620	12"	12' 6 1/4"
585	415	10 & 5	92,500	25,570	34,420	18,680	820	7 1/2	1,030	620	12"	13' 11 1/4"
630	447	20 & 10	112,700	22,710	31,210	15,500	660	7 1/2	1,030	620	12"	13' 2 3/4"
645	457	15 & 7 1/2	102,000	25,760	34,610	18,680	820	7 1/2	1,030	620	12"	13' 11 1/4"
690	489	20 & 10	109,300	25,910	34,760	18,680	820	7 1/2	1,030	620	12"	13' 11 1/4"
725	514	25 & 15	114,800	26,450	35,300	18,680	820	7 1/2	1,030	620	12"	13' 11 1/4"
755	535	25 & 15	114,000	29,390	38,590	21,870	990	7 1/2	1,030	620	12"	14' 7 3/4"
775	550	30 & 15	117,000	29,930	39,130	21,870	990	7 1/2	1,030	620	12"	14' 7 3/4"
PMCB- 850	603	(2)15	132,200	34,020	46,270	12,940	1,100	(2)5	1,370	850	12"	13' 11 1/4"
910	645	(2)20	145,000	34,260	46,510	12,940	1,100	(2)5	1,370	850	12"	13' 11 1/4"
950	674	(2)20	142,400	38,480	51,100	15,150	1,320	(2)5	1,370	850	12"	14' 7 3/4"
960	681	(2)25	153,000	34,540	46,790	12,940	1,100	(2)5	1,370	850	12"	13' 11 1/4"
1000	709	(2)25	150,000	38,760	51,380	15,150	1,320	(2)5	1,370	850	12"	14' 7 3/4"
1030	730	(2)30	154,200	39,080	51,700	15,150	1,320	(2)5	1,370	850	12"	14' 7 3/4"
PMCB-1060	752	(2)10 & (2)5	185,700	44,260	61,380	15,500	1,320	(2)7 1/2	2,060	1,620	14"	13' 2 3/4"
1175	833	(2)15 & (2)7 1/2	209,000	44,640	61,760	15,500	1,320	(2)7 1/2	2,060	1,620	14"	13' 2 3/4"
1260	894	(2)20 & (2)10	225,400	44,960	62,080	15,500	1,320	(2)7 1/2	2,060	1,620	14"	13' 2 3/4"
1380	979	(2)20 & (2)10	218,600	51,360	69,180	18,680	1,640	(2)7 1/2	2,060	1,620	14"	13' 11 1/4"
1510	1,071	(2)25 & (2)15	228,000	58,320	76,820	21,870	1,980	(2)7 1/2	2,060	1,620	14"	14' 7 3/4"
1550	1,100	(2)30 & (2)15	234,000	59,400	77,900	21,870	1,980	(2)7 1/2	2,060	1,620	14"	14' 7 3/4"

* Tons at standard conditions: HCFC-22 and HFC-134a. 105° condensing, 40° suction and 78° W.B.; ammonia 96.3° condensing, 20° suction and 78° W.B.

** Gallons shown is water in suspension in unit and piping. Allow for additional water in bottom of remote sump to cover pump suction and strainer during operation. (12" would normally be sufficient.)

Engineering Dimensions & Data

Power Miser Models
PMCB-435 to 1770

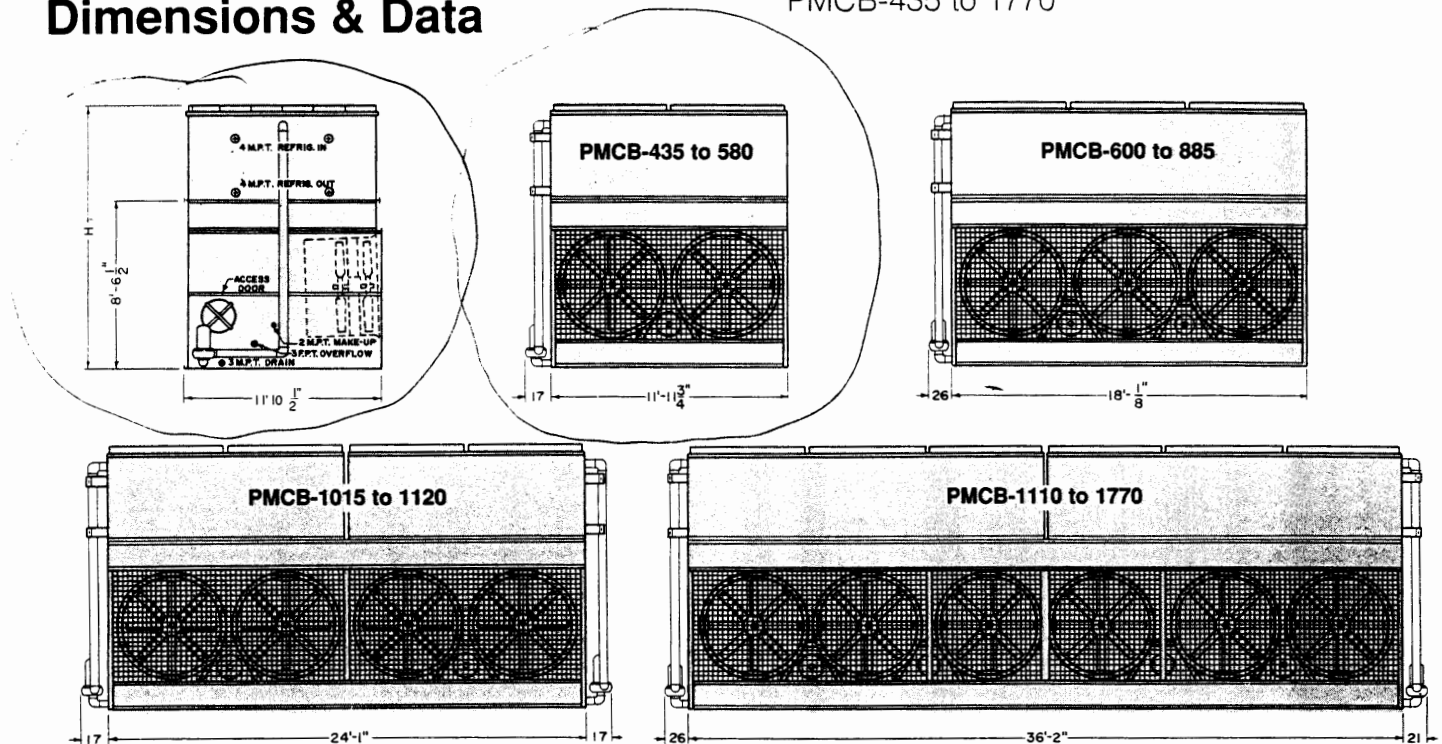

TABLE 9 - Engineering Data

UNIT NO.*	R-717 Tons*	FANS		WEIGHTS			R-717 Operating Charge	SPRAY PUMP		REMOTE SUMP		HEIGHT
		HP	CFM	Shipping	Operating	Heaviest Section		HP	GPM	Gallons Req'd**	Conn. Size	
PMCB- 435	309	15	74,100	18,000	24,410	13,150	530	5	800	500	10"	14' 23/4"
475	337	15	73,900	20,650	27,320	15,790	660	5	800	500	10"	14' 11 1/4"
495	351	25	87,200	18,260	24,670	13,150	530	5	800	500	10"	14' 23/4"
510	362	30	89,900	18,420	24,830	13,150	530	5	800	500	10"	14' 23/4"
535	379	25	85,000	20,910	27,580	15,790	660	5	800	500	10"	14' 11 1/4"
540	383	20	79,400	23,330	30,240	18,440	790	5	800	500	10"	15' 73/4"
560	397	25	84,000	23,470	30,380	18,440	790	5	800	500	10"	15' 73/4"
580	411	30	86,900	23,630	30,540	18,440	790	5	800	500	10"	15' 73/4"
PMCB- 600	426	20 & 10	129,000	22,700	31,520	15,180	600	7 1/2	1,200	730	12"	13' 6 1/4"
660	468	15 & 7 1/2	118,000	26,550	35,870	18,920	800	7 1/2	1,200	730	12"	14' 23/4"
705	500	20 & 10	125,500	26,710	36,030	18,920	800	7 1/2	1,200	730	12"	14' 23/4"
770	546	20 & 10	121,900	30,710	40,510	22,740	1,000	7 1/2	1,200	730	12"	14' 11 1/4"
805	571	20 & 10	120,800	34,350	44,650	26,560	1,200	7 1/2	1,200	730	12"	15' 73/4"
815	578	25 & 15	128,800	31,250	41,050	22,740	1,000	7 1/2	1,200	730	12"	14' 11 1/4"
855	606	30 & 15	135,000	31,410	41,210	22,740	1,000	7 1/2	1,200	730	12"	14' 11 1/4"
885	628	30 & 15	132,800	35,430	45,730	26,560	1,200	7 1/2	1,200	730	12"	15' 73/4"
PMCB-1015	720	(2)20	160,000	40,990	54,600	15,790	1,320	(2)5	1,600	1,000	14"	14' 11 1/4"
1080	766	(2)20	158,800	46,110	60,210	18,440	1,580	(2)5	1,600	1,000	14"	15' 73/4"
1120	794	(2)25	168,000	46,390	60,490	18,440	1,580	(2)5	1,600	1,000	14"	15' 73/4"
PMCB-1110	787	(2)15 & (2)7 1/2	238,000	44,550	62,460	15,180	1,200	(2)7 1/2	2,400	1,460	16"	13' 6 1/4"
1320	936	(2)15 & (2)7 1/2	236,000	52,550	71,460	18,920	1,600	(2)7 1/2	2,400	1,460	16"	14' 23/4"
1410	1,000	(2)20 & (2)10	251,000	52,870	71,780	18,920	1,600	(2)7 1/2	2,400	1,460	16"	14' 23/4"
1485	1,053	(2)25 & (2)15	264,000	53,950	72,860	18,920	1,600	(2)7 1/2	2,400	1,460	16"	14' 23/4"
1540	1,092	(2)30 & (2)15	274,000	54,270	73,180	18,920	1,600	(2)7 1/2	2,400	1,460	16"	14' 23/4"
1630	1,156	(2)25 & (2)15	257,600	61,950	81,820	22,740	2,000	(2)7 1/2	2,400	1,460	16"	14' 11 1/4"
1710	1,213	(2)30 & (2)15	270,000	62,270	82,140	22,740	2,000	(2)7 1/2	2,400	1,460	16"	14' 11 1/4"
1770	1,255	(2)30 & (2)15	265,600	70,310	91,180	26,560	2,400	(2)7 1/2	2,400	1,460	16"	15' 73/4"

*Tons at standard conditions: HCFC-22 and HFC-134a. 105° condensing, 40° suction and 78° W.B.; ammonia 96.3° condensing, 20° suction and 78° W.B.

**Gallons shown is water in suspension in unit and piping. Allow for additional water in bottom of remote sump to cover pump suction and strainer during operation. (12" would normally be sufficient.)



Centrifugal Fan Models
LSCB-36 to 170

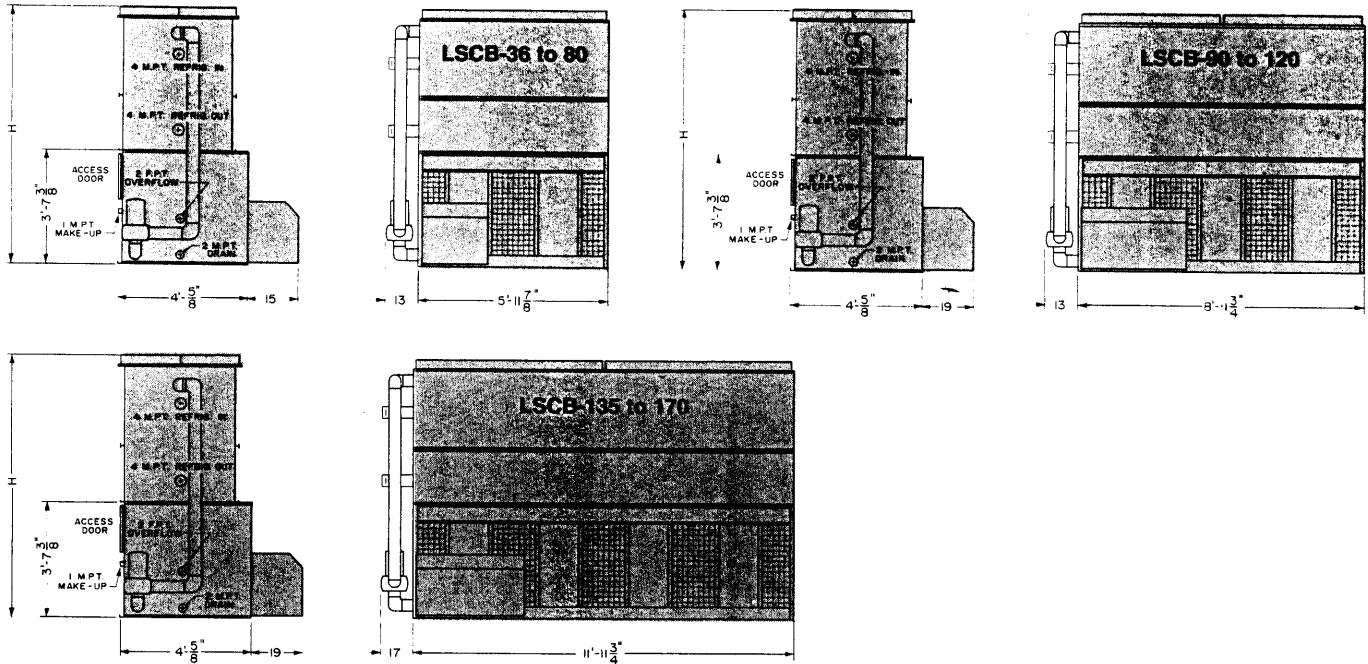

TABLE 10 - Engineering Data

UNIT NO.	R-717 Tons	FANS		WEIGHTS				R-717 SPRAY PUMP		REMOTE SUMP		HEIGHT
		HP	CFM	Shipping	Operating	Heaviest Section	Operating Charge	HP	GPM	Gallons Req'd**	Conn. Size	
LSCB-36	26	3	10,200	2,220	3,170	2,220	38	3/4	120	80	4"	6' 8 1/2"
41	29	5	12,000	2,280	3,230	2,280	38	3/4	120	80	4"	6' 8 1/2"
48	34	3	10,000	2,710	3,550	1,680	58	3/4	120	80	4"	7' 4"
54	38	5	11,800	2,790	3,630	1,680	58	3/4	120	80	4"	7' 4"
65	46	5	11,600	3,100	3,960	2,040	77	3/4	120	80	4"	7' 11 1/2"
70	50	7 1/2	13,000	3,190	4,050	2,040	77	3/4	120	80	4"	7' 11 1/2"
75	53	5	11,400	3,420	4,300	2,430	96	3/4	120	80	4"	8' 7"
80	57	7 1/2	12,800	3,570	4,450	2,430	96	3/4	120	80	4"	8' 7"
LSCB-90	64	5	15,300	4,380	5,700	3,000	115	1	180	120	6"	7' 11 1/2"
100	71	7 1/2	17,400	4,520	5,840	3,000	115	1	180	120	6"	7' 11 1/2"
110	78	10	19,200	4,650	5,970	3,000	115	1	180	120	6"	7' 11 1/2"
120	85	10	18,800	5,050	6,390	3,590	144	1	180	120	6"	8' 7"
LSCB-135	96	10	23,800	5,720	7,580	3,960	154	1 1/2	245	170	6"	7' 11 1/2"
150	106	15	26,600	5,840	7,700	3,960	154	1 1/2	245	170	6"	7' 11 1/2"
155	110	10	23,300	6,500	8,410	4,750	192	1 1/2	245	170	6"	8' 7"
170	121	15	26,100	6,650	8,560	4,750	192	1 1/2	245	170	6"	8' 7"

* Tons at standard conditions HCFC-22 and HFC-134a. 105° condensing, 40° suction and 78° W.B.; ammonia 96.3° condensing, 20° suction and 78° W.B.

** For external static pressure up to 1/2" use next larger size fan motor.

*** Gallons shown is water in suspension in unit and piping. Allow for additional water in bottom of remote sump to cover pump suction and strainer during operation. (12" would normally be sufficient.)

Engineering Dimensions & Data

Centrifugal Fan Models LSCB-185 to 385

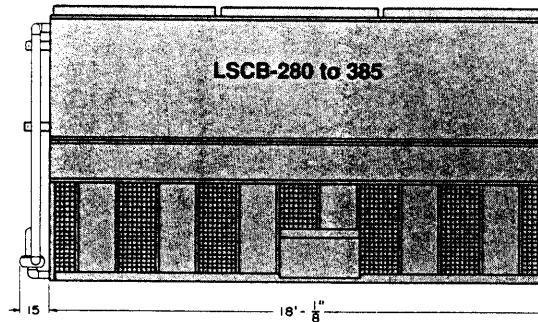
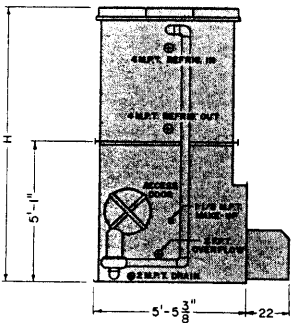
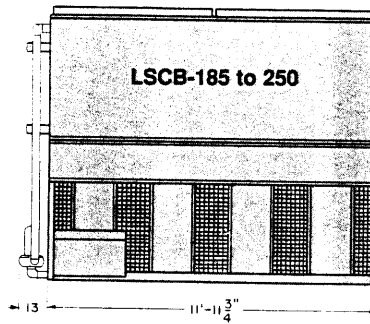
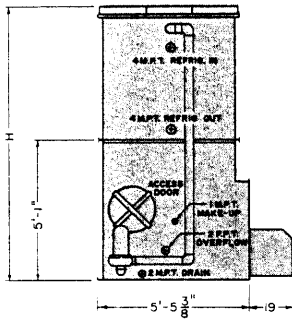

TABLE 11 - Engineering Data

UNIT NO.*	R-717 Tons*	FANS		WEIGHTS			R-717 Operating Charge	SPRAY PUMP		REMOTE SUMP		HEIGHT
		HP	CFM	Shipping	Operating	Heaviest Section		HP	GPM	Gallons Req'd**	Conn. Size	
LSCB-185	131	10	32,900	7,910	10,240	5,470	220	2	345	230	8"	9' 9 1/4"
200	142	15	35,700	8,060	10,390	5,470	220	2	345	230	8"	9' 9 1/4"
210	149	20	37,600	8,190	10,520	5,470	220	2	345	230	8"	9' 9 1/4"
225	160	15	34,700	9,070	11,470	6,580	275	2	345	230	8"	10' 5 3/4"
240	170	20	37,200	9,200	11,600	6,580	275	2	345	230	8"	10' 5 3/4"
250	177	20	36,800	10,210	12,670	7,700	330	2	345	230	8"	11' 2 1/4"
LSCB-280	199	15	47,300	12,070	15,130	8,330	330	3	515	340	8"	9' 9 1/4"
300	213	20	52,000	12,200	15,260	8,330	330	3	515	340	8"	9' 9 1/4"
315	223	25	55,500	12,400	15,460	8,330	330	3	515	340	8"	9' 9 1/4"
335	238	20	50,400	13,770	16,900	9,990	410	3	515	340	8"	10' 5 3/4"
355	252	25	54,300	13,970	17,100	9,990	410	3	515	340	8"	10' 5 3/4"
370	262	30	57,700	14,120	17,250	9,990	410	3	515	340	8"	10' 5 3/4"
385	273	30	56,500	15,590	18,810	11,660	495	3	515	340	8"	11' 2 1/4"

* Tons at standard conditions HCFC-22 and HFC-134a. 105° condensing, 40° suction and 78° W.B.; ammonia 96.3° condensing, 20° suction and 78° W.B.

** For external static pressure up to 1/2" use next larger size fan motor.

*** Gallons shown is water in suspension in unit and piping. Allow for additional water in bottom of remote sump to cover pump suction and strainer during operation. (12" would normally be sufficient.)



Centrifugal Fan Models LSCB-400 to 1610

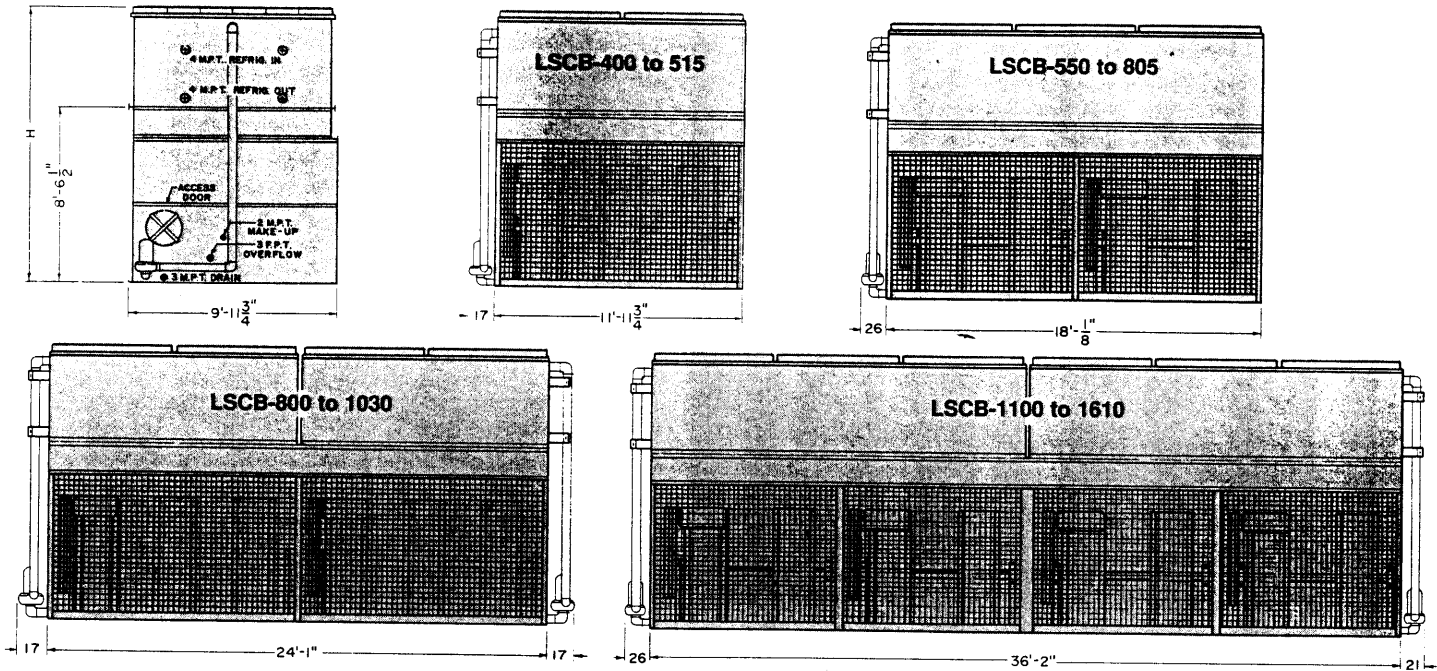

TABLE 12 - Engineering Data

UNIT NO.	R-717 Tons*	FANS		WEIGHTS			R-717 Operating Charge	SPRAY PUMP		REMOTE SUMP		HEIGHT
		HP	CFM	Shipping	Operating	Heaviest Section		HP	GPM	Gallons Req'd**	Conn. Size	
LSCB-400	284	30	70,900	15,870	21,970	10,740	440	5	685	410	10"	13' 23/4"
430	305	25	66,600	18,020	24,360	12,940	550	5	685	410	10"	13' 11 1/4"
450	319	30	69,500	18,170	24,510	12,940	550	5	685	410	10"	13' 11 1/4"
480	340	40	75,600	18,410	24,750	12,940	550	5	685	410	10"	13' 11 1/4"
500	355	40	74,200	20,420	26,990	15,150	660	5	685	410	10"	14' 7 3/4"
515	365	50	77,200	20,480	27,050	15,150	660	5	685	410	10"	14' 7 3/4"
LSCB-550	390	(2)15	97,400	22,990	31,860	15,500	660	7 1/2	1,030	600	12"	13' 23/4"
590	418	(2)20	105,000	23,370	32,240	15,500	660	7 1/2	1,030	600	12"	13' 23/4"
625	443	(2)25	111,200	23,610	32,480	15,500	660	7 1/2	1,030	600	12"	13' 23/4"
650	461	(2)20	102,900	26,670	35,900	18,680	820	7 1/2	1,030	600	12"	13' 11 1/4"
690	489	(2)25	109,000	26,910	36,140	18,680	820	7 1/2	1,030	600	12"	13' 11 1/4"
720	511	(2)30	114,000	27,140	36,370	18,680	820	7 1/2	1,030	600	12"	13' 11 1/4"
755	535	(2)30	113,000	30,350	39,930	21,870	990	7 1/2	1,030	600	12"	14' 7 3/4"
805	571	(2)40	121,500	31,180	40,760	22,490	990	7 1/2	1,030	600	12"	14' 7 3/4"
LSCB-800	567	(2)30	141,800	31,400	43,600	10,740	880	(2)5	1,370	820	12"	13' 23/4"
860	610	(2)25	133,200	35,710	48,370	12,940	1,100	(2)5	1,370	820	12"	13' 11 1/4"
900	638	(2)30	139,000	35,910	48,570	12,940	1,100	(2)5	1,370	820	12"	13' 11 1/4"
960	681	(2)40	151,200	36,390	49,070	12,940	1,100	(2)5	1,370	820	12"	13' 11 1/4"
1000	709	(2)40	148,400	39,770	52,670	15,150	1,320	(2)5	1,370	820	12"	14' 7 3/4"
1030	730	(2)50	154,400	39,980	52,890	15,150	1,320	(2)5	1,370	820	12"	14' 7 3/4"
LSCB-1100	780	(4)15	194,800	45,620	63,650	15,500	1,320	(2)7 1/2	2,060	1,500	14"	13' 23/4"
1180	837	(4)20	210,000	46,140	64,170	15,500	1,320	(2)7 1/2	2,060	1,500	14"	13' 23/4"
1250	887	(4)25	222,400	46,620	64,650	15,500	1,320	(2)7 1/2	2,060	1,500	14"	13' 23/4"
1310	929	(4)30	230,400	47,260	65,290	15,500	1,320	(2)7 1/2	2,060	1,500	14"	13' 23/4"
1380	979	(4)25	218,000	53,230	71,960	18,680	1,640	(2)7 1/2	2,060	1,500	14"	13' 11 1/4"
1440	1,021	(4)30	228,000	53,490	72,230	18,680	1,640	(2)7 1/2	2,060	1,500	14"	13' 11 1/4"
1510	1,071	(4)30	226,000	60,100	79,380	21,870	1,980	(2)7 1/2	2,060	1,500	14"	14' 7 3/4"
1610	1,142	(4)40	243,000	61,750	81,030	22,490	1,980	(2)7 1/2	2,060	1,500	14"	14' 7 3/4"

* Tons at standard conditions HCFC-22 and HFC-134a. 105° condensing, 40° suction and 78° W.B.; ammonia 96.3° condensing, 20° suction and 78° W.B.

** For external static pressure up to 1/2" use next larger size fan motor.

*** Gallons shown is water in suspension in unit and piping. Allow for additional water in bottom of remote sump to cover pump suction and strainer during operation. (12" would normally be sufficient.)

Optional Equipment

Two Speed Fan Motors

In most applications two-speed fan motors will provide adequate control of the condenser capacity while reducing energy consumption and allowing lower sound levels.

When optional multi-speed fan motors are ordered, they are normally supplied in the more economical two speed-one winding design, although two speed-two winding types are available at additional cost. Both designs are 1800/900 RPM and can be wound for any single voltage between 200 and 575 volts in either 50 or 60 hertz. (See page 7 for more details.)

Capacity Control Dampers

Capacity control dampers are available for all centrifugal fan condensers. These dampers are installed in the fan housings to modulate the quantity of air flowing through the unit. A 24 volt electric actuator is mounted on the fan section and connected to the dampers through mechanical linkage. The actuator is positioned by a signal from a proportional action pressure controller. The pressure control is provided for field installation in the discharge line from the compressor or in the receiver. A 24 volt step down transformer is also included.

Condensers supplied with multiple circuits may require head pressure control for two or more of the individual circuits. For these applications, a temperature control, mounted in the condenser pan, is substituted for the standard pressure control. The head pressure is maintained indirectly for each circuit by monitoring the spray water temperature.

When the dampers close to their minimum airflow position, an auxiliary switch built into the electric actuator opens to turn the fan motor off. (See page 8 for additional information.)

Pan Freeze Protection

REMOTE SUMP

Whenever a condenser is idled during subfreezing weather, the water in the sump must be protected from freezing and damaging the pan. The simplest and most reliable method of accomplishing this is with a remote sump tank located in a heated space in the building under the condenser. The recirculating water pump is mounted at the remote sump and whenever it is shut-off, all of the water drains into the indoor tank. When a condenser is ordered for remote sump operation, the standard float valve and strainer are omitted, and the unit is provided with an oversized bottom water outlet connection. Where a remote sump is not possible, a supplementary means of heating the pan water must be provided.

ELECTRIC HEATERS

Electric immersion heaters are available factory installed in the basin of the condenser. They are sized to maintain a +40°F pan water temperature at 0° ambient temperature with the fans and pumps off. They are furnished with a combination thermostat/low water protection device to cycle the heater on when required and to prevent the heater elements from energizing unless they are completely submerged. Components are enclosed in rugged, weatherproof enclosures for outdoor use. The heater power contactors and electric wiring are not included as standard.

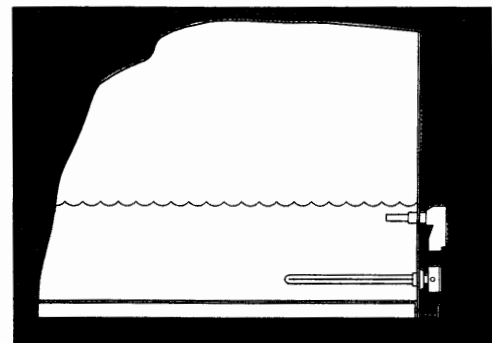

TABLE 13 - Electric Pan Heaters

Model No.	KW
5 Ft. Wide PMCB Models	
PMCB-175 to 240	5
250 to 375	(2)4
10 Ft. Wide PMCB Models	
PMCB-290 to 480	8
450 to 775	(2)6
850 to 1030	(2)8
1060 to 1550	(2)12
12 Ft. Wide PMCB Models	
PMCB-435 to 580	(2)6
600 to 885	(2)8
1015 to 1120	(2)12
1110 to 1770	(2)16
Centrifugal Fan, LSCB Models	
LSCB- 36 to 80	2
90 to 170	3
185 to 250	4
280 to 385	(2)3
400 to 515	7
550 to 805	(2)5
800 to 1030	(2)7
1100 to 1610	(2)10

Electric Water Level Control

EVAPCO evaporative condensers are available with an optional electric water level control system in place of the standard mechanical makeup valve and float assembly. This package provides very accurate control of the pan water level and does not require field adjustment, even under widely variable operating conditions.

The control was designed by EVAPCO and consists of multiple heavy duty stainless steel electrodes. These electrodes are mounted external to the unit in a vertical standpipe. For winter operation, the standpipe must be wrapped with electric heating cable and insulated to protect it from freeze up.

The weather protected slow closing solenoid valve for the makeup water connection is factory supplied and is ready for piping to a water supply with a pressure between 20 psig (minimum) and 50 psig (maximum).

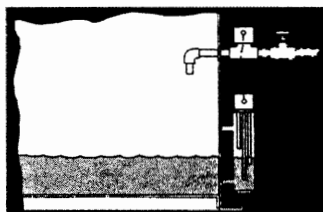

ELECTRIC WATER LEVEL CONTROL

Multiple Circuit Coils

Evaporative condensers may be ordered with multiple circuit coils to match various system requirements. On halocarbon refrigerant applications, multiple compressor systems are common, with each requiring an individual circuit on the condenser coil. In ammonia screw compressor applications, a separate section of the condenser coil may be used to cool water or a glycol-water mixture for the system oil cooler. Both the centrifugal and vane axial fan models are available with multiple circuit coil arrangements. Consult the factory for circuiting information.

Solid Bottom Panels for Ductwork

When centrifugal fan units are installed indoors and intake air is ducted to the unit, a solid bottom panel is required to completely enclose the fan section and prevent the unit from drawing room air into the fan intakes. When this is ordered, air inlet screens are omitted and the fan bearings are provided with extended lubrication fittings to facilitate maintenance from outside the duct.

Screened Bottom Panels

Protective inlet screens are provided on the front of the fan section (except as noted above) on both the Power-Mizer and the Centrifugal Fan models. Screens are not provided on the bottom of the fan section since most units are mounted on the roof or at ground level.

If units are installed in an elevated position, bottom screens are recommended for safety protection. They can be supplied by the factory at additional cost or added by the installing contractor.

Sub-Cooling Coils

EVAPCO's standard subcooling coil is designed to provide 10°F of refrigerant liquid subcooling on halocarbon refrigerants. The subcooling coil section is mounted between the condensing coil and the pan section and will add 7" to the height of most unit sizes. The coil assembly is tested at 350 psig air pressure under water and hot-dip galvanized to ensure maximum corrosion protection.

A subcooling coil in an evaporative condenser is not recommended for ammonia refrigeration systems. The physical properties of ammonia as a refrigerant provide lower static head losses and relatively small amounts of flash gas as compared to halocarbon refrigerants. Ammonia refrigeration systems are also less sensitive to small amounts of flash gas due to their expansion devices and basic system designs. The economical use of a subcooling coil is, therefore, limited for these applications.

Application

Design

EVAPCO units are heavy-duty construction and designed for long trouble-free operation. Proper equipment selection, installation and maintenance is, however, necessary to ensure good unit performance. Some of the major considerations in the application of a condenser are presented below. For additional information, contact the factory.

Structural Steel Support

The recommended method of support for EVAPCO condensers is two structural "I" beams located under the outer flanges and running the entire length of the unit. Mounting holes 3/4" in diameter, are located in the bottom channels of the pan section to provide for bolting to the structural steel; refer to certified drawings from the factory for bolt hole locations.

Beams should be level to within 1/8" in 6' before setting the unit in place. Do not level the unit by shimming between it and the "I" beams as this will not provide proper longitudinal support.

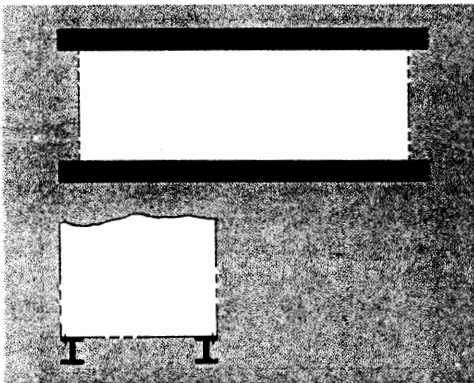

STRUCTURAL STEEL SUPPORT

Air Circulation

In reviewing the system design and unit location, it is important that proper air circulation be provided. The best location is on an unobstructed roof top or on ground level away from walls and other barriers. Care must be taken when locating condensers in wells or enclosures or next to high walls. The potential for recirculation of the hot, moist discharge air back into the fan intake exists. Recirculation raises the wet bulb temperature of the entering air causing the condensing pressure to rise above design. For these cases, a discharge hood or ductwork should be provided to raise the overall unit height even with the adjacent wall, thereby reducing the chance of recirculation. Engineering assistance is available from the factory to identify potential recirculation problems and recommend solutions.

For additional information regarding layout of evaporative condensers, see EVAPCO Bulletin entitled "Equipment Layout."

Piping

Condenser piping should be designed and installed in accordance with generally accepted engineering practice. All piping should be anchored by properly designed hangers and supports with allowance made for possible expansion and contraction. No external loads should be placed upon condenser connections, nor should any of the pipe supports be anchored to the unit framework. For additional information concerning refrigerant pipe sizing and layout, see EVAPCO Bulletin entitled "Piping Evaporative Condensers".

Indoor Installations

Centrifugal fan models can be installed indoors where it is desirable to hide the unit or where it is the only location available. Discharge ductwork is required for these installations. Normally it is best to use the room as a plenum for inlet air, but inlet ductwork can be used if required.

The design of ductwork should be symmetrical to provide even air distribution across both intake and discharge openings. The static pressure loss imposed by the ductwork must not exceed 1/2". Care must be taken to provide large access doors in the ductwork for accessibility to the unit fan section, eliminators and water distribution system for normal maintenance.

The centrifugal fan condenser can handle the external static of ductwork by using the next larger size fan motor. Units installed with inlet ductwork should also be ordered with the solid bottom panel option. Drawings are available from the factory showing how to make ductwork connections.

Recirculating Water System Freeze Protection

The simplest and most foolproof method of protecting the recirculating water system from freeze-up is through the use of a remote sump located inside the building below the unit. The recirculating water pump is mounted at the remote sump, and whenever it is shut off, all of the water in the condenser rains back to the warm inside sump. The Engineering Data Tables presented on pages 14-19 provide information to size the remote sump tank.

If a remote sump cannot be used, pan heaters are available, either steam, hot water, or electric type, to keep the pan water from freezing when the unit is shut down. Water lines to and from the unit, the pump and pump piping up to the overflow connection must also be wrapped with electric heating cable and insulated to protect them from freeze-up. The condenser cannot be operated dry (fans on, pump off) unless water is completely drained from the pan. The pan heaters are sized to prevent pan water from freezing when the unit is shut down, but they are not sufficient to prevent freeze-up in a condenser operating dry.



Evaporative Condenser Specifications

Furnish and install as shown on the plans an EVAPCO Model _____ evaporative condenser. Each unit shall have condensing capacity of _____ BTUH heat rejection, operating with _____ refrigerant at _____°F condensing temperature and _____°F design wet bulb temperature.

Pan and Casing

The pan and casing shall be constructed of G-235 hot-dip galvanized steel for long life and durability. The heat transfer section shall be removable from the pan to provide easy handling and rigging.

The pan/fan section shall include fans, motors and drives mounted and aligned at the factory. These items shall be located in the dry entering air stream to provide maximum service life and easy maintenance. Standard pan accessories shall include circular access doors, stainless steel strainers, wastewater bleed line with adjustable valve and brass makeup valve, with an unsinkable foam filled plastic float.

Model PMCB Power-Mizer Fans/Drives

Fans shall be vane-axial type constructed of cast aluminum alloy blades. They shall be arranged in a two-stage system installed in a closely fitted cowl with venturi air inlet and air stabilizing vanes. Fan shaft bearings shall be heavy-duty self aligning ball type with grease fittings extended to the outside of the unit.

The fan drive shall be solid backed Power-Band constructed of neoprene with polyester cords and designed for 150% of motor nameplate horsepower. Drives are to be mounted and aligned at the factory.

Model LSCB Centrifugal Fans/Drives

Fans shall be forwardly curved centrifugal type of hot-dip galvanized construction. The fans shall be factory installed into the pan-fan section, and statically and dynamically balanced for vibration free operation. Fans shall be mounted on either a solid steel shaft or a hollow steel shaft with forged bearing journals. The fan shaft shall be supported by heavy-duty, self-aligning bearings with cast-iron housings and lubrication fittings for maintenance.

The fan drive shall be V-belt type with taper lock sheaves designed for 150% of the motor nameplate horsepower. Drives are to be mounted and aligned at the factory.

Power-Mizer/
Centrifugal Fan Models

Fan Motor

_____ horsepower totally enclosed fan cooled motor(s) with 1.15 service factor shall be furnished suitable for outdoor service on _____ volts, _____ hertz, and _____ phase. Motor(s) shall be mounted on an adjustable base.

Heat Transfer Coil

The coil(s) shall be all prime surface steel, encased in steel framework with the entire assembly hot-dip galvanized after fabrication. Coil(s) shall be designed with sloping tubes for free drainage of liquid refrigerant and tested to 350 P.S.I.G. air pressure under water.

Water Distribution System

The system shall provide a water flow rate of not less than 6 GPM over each square foot of unit face area to ensure proper flooding of the coil. The spray header shall be constructed of schedule 40, PVC pipe for corrosion resistance. All spray branches shall be removable and include a threaded end plug for cleaning. The water shall be distributed over the entire coil surface by precision molded ABS spray nozzles (1" x 1/2" orifice) with internal anti-sludge rings to eliminate clogging. Nozzles shall be threaded into spray header to provide easy removal for maintenance.

Water Recirculation Pump

The pump(s) shall be a close-coupled, bronze fitted, centrifugal type with mechanical seal, installed vertically at the factory to allow free drainage on shut down. _____ horsepower totally enclosed, motor shall be furnished suitable for outdoor service on _____ volts, _____ hertz, and _____ phase.

Eliminators

The eliminators shall be constructed entirely of PVC that has been specially treated to resist ultra-violet light. Assembled in easily handled sections, the eliminator blades shall be spaced on 1-inch centers and shall incorporate three changes in air direction to assure removal of entrained moisture from the discharge air stream. They shall have a hooked leaving edge to direct the discharge air away from the fans to minimize recirculation.

Finish

All pan and casing materials shall be constructed of G-235 heavy gauge mill hot-dip galvanized steel for maximum protection against corrosion. During fabrication, all panel edges shall be coated with a 95% pure zinc-rich compound.



COOLING TOWERS

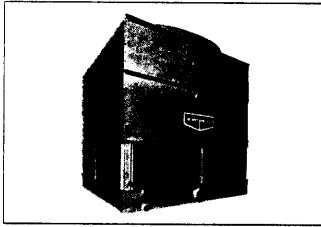

ICT/AT Series

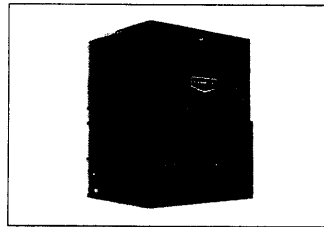

LSTA Series

CLOSED CIRCUIT COOLERS

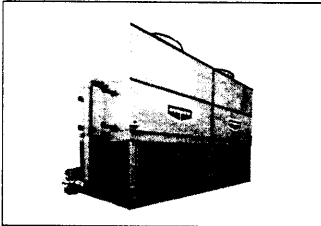

ATW Series

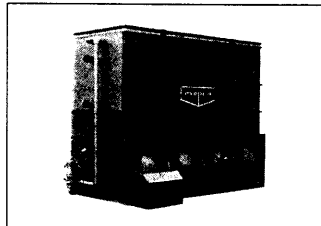

LSWA Series

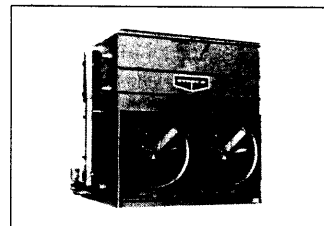

PMWA Series

EVAPORATIVE CONDENSERS

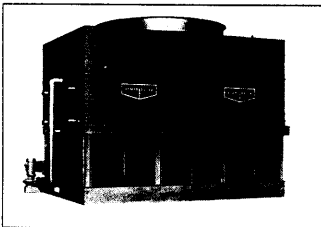

ATC Series

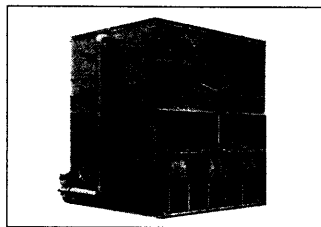

LSCB Series

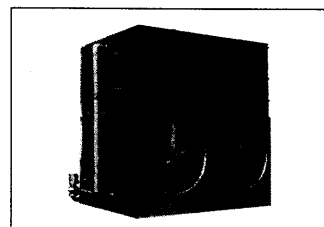

PMCB Series

EVAPORATORS

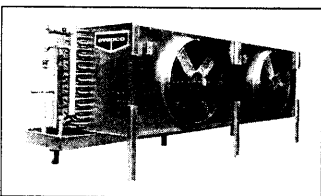

NTS/NTL Series

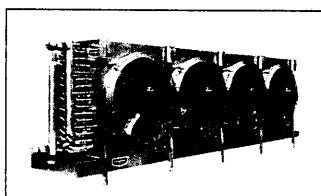

NTX Series

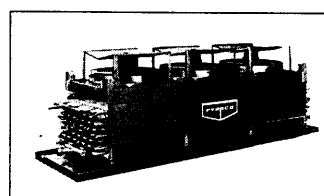

NTW Series

EVAPCO products are manufactured in twelve facilities worldwide

EVAPCO, INC. (World Headquarters) P.O. Box 1300, Westminster, Maryland 21158 USA Phone (410) 756-2600 FAX (410) 756-6450

EVAPCO INC.
5151 Allendale Lane
Taneytown, Maryland 21787

EVAPCO MIDWEST
York Road
Greenup, Illinois 62428
Phone (217) 923-3431
Fax (217) 923-3300

EVAPCO WEST, INC.
1900 Almond Avenue
Madera, California 93637
Phone (209) 673-2207
Fax (209) 673-2378

EVAPCO EUROPE, S.R.L.
Via Ciro Menotti 10, 1-20017
Passirana di Rho
Milano, Italy
Phone (39) 2 93-50-80-14
Fax (39) 2 93-50-08-40

EVAPCO EUROPE, S.R.L.
Via Dosso, 2, Pieteda
Sondrio, Italy
Phone (39) 342-370-175
Fax (39) 342-370-575

EVAPCO EUROPE
Falcon House - Unit B
Caswell Road
Brackmills Industrial Estate
Northampton NN47PL
England, United Kingdom
Phone (44) 1 604-766188
Fax (44) 1 604-766151

CIMCO
65 Villiers St., Toronto, Ontario
M5A 3S1, Canada
Phone (416) 465-7581
Fax (416) 465-8815

AQUA-COOL TOWERS, PTY, LTD.
34-42 Melbourne St.
P.O. Box 436
Riverstone, N.S.W. Australia 2765
Phone (61) 2-627-3322
Fax (61) 2-627-1715

AIR EVAPCO (Ltd.)
3 El Mamalik Street
Roxy, Heliopolis
Cairo, Egypt
Phone (20) 2-2585451
Fax (20) 2-2578882

EVAPCO S.A. (PTY.) LTD.
10 Quality and C/R Barlow Roads
ISANDO
Johannesburg, Republic of South Africa
Phone (27) 11-392-6630
Fax (27) 11-392-6615

SHANGHAI HE ZHONG EVAPCO REFRIGERATION LTD.
855 Yang Tai Road
Bao Shan Area
Shanghai, P.R. China P. Code: 201901
Phone (86) 21-6537-5646
Fax (86) 21-6537-5650

REFRIGERATION VALVES AND SYSTEMS
P.O. Box 4649, 1520 Crosswind Drive
Bryan, Texas 77805-4649
Phone (409) 778-0095
Fax (409) 778-0030

PERFORMANCE VS. SCALE

Excessive scale buildup negatively impacts the thermal performance of evaporative condensers. More significant to the end-user, is the fact that operating costs significantly increase when scale buildup inhibits heat transfer forcing the equipment to work harder to maintain the design condensing temperature. Knowing this, water treatment programs are designed to control the buildup of scale on evaporative equipment. In real world applications, we must accept that scale can only be controlled, and not completely eliminated.

With respect to *evaporative* cooling, a CXV unit will typically cool the same load as a similarly sized ATC, but with about half the coil surface. With an equivalent heat load, the CXV unit will reject the same amount of heat through half the amount of coil...i.e. a higher concentration of heat rejection. In theoretical terms, this can be expressed in terms of the Heat Transfer Co-efficient "K" (BTU/hr-sqft-F). Restated, the same load through half the surface area means the CXV will have a "K" value approximately two times higher than the Evapco unit.

Scale build up has a greater impact on heat transfer processes with high "K" values than heat transfer processes with lower "K" values.

As a result, a typical scale buildup of 1/32" will reduce the **CXV capacity by 30%**. In other words, the CXV is twice as vulnerable to scale as compared to an equivalent Evapco coil! *The following graph shows that the performance of a CXV is greatly affected by even the smallest amount of scale.*

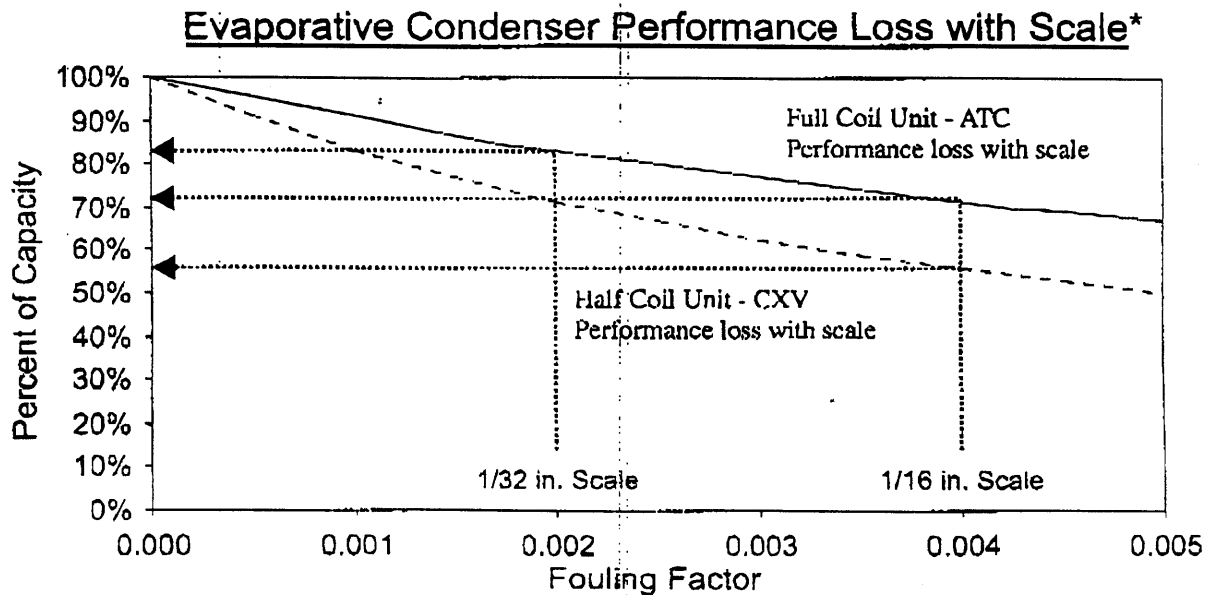

*Refer to page 8 for basis of calculations

CXV UNITS OPERATE IN THE "SCALE DANGER ZONE"

PERFORMANCE VS. SCALE (REFERENCE PAGE)

$$Q = K \times A \times \text{LMTD}$$

Where Q = Rate of heat transfer
 K = Overall heat transfer coefficient (BTU/hr.sqft.F)
 A = Coil surface area (sqft)
 LMTD = Log mean temperature difference (F)

K , the overall heat transfer coefficient can be further broken down as follows:

$$K = \frac{1}{(1/K_{cl}) + F}$$

Where K_{cl} = Heat transfer coefficient before fouling
 F = Fouling adjustment factor

COMPARISON OF THE EFFECT OF FOULING:

ATC CONDENSER	CXV CONDENSER
Assume $K = 100$	Assume $K = 200$
If there is no fouling then $F = 0$ and $K = K_{cl} = 100$	If there is no fouling then $F = 0$ and $K = K_{cl} = 200$
If there is 1/32" of scale with $F = 0.002$ Then $K = K_{(WITH FOULING)}$	If there is 1/32" of scale with $F = 0.002$ Then $K = K_{(WITH FOULING)}$
Using $K_{(WITH FOULING)} = \frac{1}{(1/K_{cl}) + F}$	Using $K_{(WITH FOULING)} = \frac{1}{(1/K_{cl}) + F}$
Using $K_{(WITH FOULING)} = \frac{1}{(1/100) + 0.002}$	Using $K_{(WITH FOULING)} = \frac{1}{(1/200) + 0.002}$
Then $K_{(WITH FOULING)} = 83.3$	Then $K_{(WITH FOULING)} = 142.86$
Capacity (with scale) = $\frac{K_{(WITH FOULING)}}{K_{(NO FOULING)}}$	Capacity (with scale) = $\frac{K_{(WITH FOULING)}}{K_{(NO FOULING)}}$
Capacity (%) (with scale) = $\frac{83.3}{100} \times 100 = 83.3\%$	Capacity (%) (with scale) = $\frac{142.86}{200} \times 100 = 71.4\%$
= 16.7 % reduction in the heat transfer coefficient due to 1/32" of scale.	= 28.6 % reduction in the heat transfer coefficient due to 1/32" of scale.