



WATER-COOLED REFRIGERANT RECOVERY AND RECYCLING UNITS

OPERATION & MAINTENANCE

Supersedes: 50.40-OM1 (904)

Form 50.40-OM1 (713)



LD17585

PORTABLE RECOVERY PAK™



LD17584

EASYTANK™



LD17583

RSR UNITS

Issue Date:
July 17, 2013



IMPORTANT!

READ BEFORE PROCEEDING!

GENERAL SAFETY GUIDELINES

This equipment is a relatively complicated apparatus. During installation, operation maintenance or service, individuals may be exposed to certain components or conditions including, but not limited to: refrigerants, materials under pressure, rotating components, and both high and low voltage. Each of these items has the potential, if misused or handled improperly, to cause bodily injury or death. It is the obligation and responsibility of operating/service personnel to identify and recognize these inherent hazards, protect themselves, and proceed safely in completing their tasks. Failure to comply with any of these requirements could result in serious damage to the equipment and the property in

which it is situated, as well as severe personal injury or death to themselves and people at the site.

This document is intended for use by owner-authorized operating/service personnel. It is expected that these individuals possess independent training that will enable them to perform their assigned tasks properly and safely. It is essential that, prior to performing any task on this equipment, this individual shall have read and understood this document and any referenced materials. This individual shall also be familiar with and comply with all applicable governmental standards and regulations pertaining to the task in question.

SAFETY SYMBOLS

The following symbols are used in this document to alert the reader to specific situations:



Indicates a possible hazardous situation which will result in death or serious injury if proper care is not taken.



Identifies a hazard which could lead to damage to the machine, damage to other equipment and/or environmental pollution if proper care is not taken or instructions are not followed.



Indicates a potentially hazardous situation which will result in possible injuries or damage to equipment if proper care is not taken.

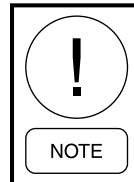

Highlights additional information useful to the technician in completing the work being performed properly.



External wiring, unless specified as an optional connection in the manufacturer's product line, is not to be connected inside the control cabinet. Devices such as relays, switches, transducers and controls and any external wiring must not be installed inside the micro panel. All wiring must be in accordance with Johnson Controls' published specifications and must be performed only by a qualified electrician. Johnson Controls will NOT be responsible for damage/problems resulting from improper connections to the controls or application of improper control signals. Failure to follow this warning will void the manufacturer's warranty and cause serious damage to property or personal injury.

CHANGEABILITY OF THIS DOCUMENT

In complying with Johnson Controls' policy for continuous product improvement, the information contained in this document is subject to change without notice. Johnson Controls makes no commitment to update or provide current information automatically to the manual owner. Updated manuals, if applicable, can be obtained by contacting the nearest Johnson Controls Service office or accessing the Johnson Controls QuickLIT website at <http://cgproducts.johnsoncontrols.com>.

Operating/service personnel maintain responsibility for the applicability of these documents to the equipment. If there is any question regarding the applicability of

these documents, the technician should verify whether the equipment has been modified and if current literature is available from the owner of the equipment prior to performing any work on the chiller.

CHANGE BARS

Revisions made to this document are indicated with a line along the left or right hand column in the area the revision was made. These revisions are to technical information and any other changes in spelling, grammar or formatting are not included.

THIS PAGE INTENTIONALLY LEFT BLANK.

TABLE OF CONTENTS

SECTION 1 - INTRODUCTION	7
Inspection – Damage – Shortage.....	7
Safety Summary.....	7
Mechanical Specifications – RSR Models.....	8
Mechanical Specifications – Portable Recovery PAK™.....	11
Mechanical Specifications – Easy Tank™.....	12
SECTION 2 - OPERATION	13
General.....	13
Prior to Starting Refrigerant Recovery	13
Operation of Refrigerant Storage/Recycle System	15
Liquid Transfer – Refrigeration Unit to RSR Storage Vehicle.....	15
Detection and Removal of Non-Condensable Gases.....	17
Charging Refrigeration Unit with Refrigerant From RSR Unit	18
SECTION 3 - DIAGRAMS	23
SECTION 4 - MAINTENANCE PROCEDURES	29
General.....	29
Compressor Model CFC 1000.....	31
SECTION 5 - REPLACEMENT PARTS AND KITS	33
Compressor Replacement.....	35
Compressor Model 16799 (RST-2240, RSR-2250 & RP-2400).....	35
Vacuum Pump – Model CRR-1	43
Repairing Oil Leaks	45
Repairing Vacuum Leaks.....	45

LIST OF FIGURES

FIGURE 1 - YORK RSR System Flow Diagram.....	15
FIGURE 2 - Wiring Diagram RSR-1100V, -1600V, -1100V114, & -1600V114	23
FIGURE 3 - Wiring Diagram RSR-2212 & -2222.....	23
FIGURE 4 - Wiring Diagram Easy PAK RP-1000V, -114V & -2200	24
FIGURE 5 - Wiring Diagram RSR-2240, -2250, -4436, -4445 & RP-2400, -3400	24
FIGURE 6 - Piping Diagram RSR-1100V, -1600V, -1100V & -1600V114	25
FIGURE 7 - Piping Diagram RSR-2212, -2222, -2240, -4436, -4445.....	26
FIGURE 8 - Piping Diagram Easy-Pak RP-1000V, -114V, -2200, -2400 & -3400	27
FIGURE 9 - Compressor Replacement Parts – Model CFC-1000	33
FIGURE 10 - Compressor Replacement Parts – Discontinued Model 16799	37
FIGURE 11 - Compressor Replacement Parts – Models RA and CK	40
FIGURE 12 - Vacuum Pump Replacement Parts – Model CRR-1	43
FIGURE 13 - Compressor Data Sheet – Model 51VSM.....	46
FIGURE 14 - Compressor Dimensions – English – 51VSM.....	47
FIGURE 15 - Compressor Dimensions – Metric – 51VSM.....	47
FIGURE 16 - Compressor Parts – 51VSM.....	48
FIGURE 17 - Compressor Maintenance Instructions – 51VSM	50
FIGURE 18 - Photo, Compressor, Belt Driven – 51VSM.....	51

LIST OF TABLES

TABLE 1 - RSR Specifications – Standard	9
TABLE 2 - RSR Specifications – Metric	10
TABLE 3 - Recovery PAK Specifications (Standard and Metric)	11
TABLE 4 - Standard Tank Options (Standard and Metric)	12
TABLE 5 - Settings for Pressure Safety Control Switches.....	13
TABLE 6 - Operation Settings.....	16
TABLE 7 - Final Vacuum/EPA Regulations	17
TABLE 8 - Pressure Difference for Determining Presence of Non-Condensable Gases.....	18
TABLE 9 - Vapor Pressure – CFC-11, CFC-12, CFC-22 and CFC-500.....	18
TABLE 10 - Vapor Pressure – HCFC-123 and HFC-134a	19
TABLE 11 - Vapor Pressure – CFC-114 and CFC-502	20
TABLE 12 - Vapor Pressure (Metric (kPa) – CFC-11, CFC-12, CFC-22 and CFC-500	21
TABLE 13 - Vapor Pressure (Metric) – HCFC-123 and HFC-134a.....	21
TABLE 14 - Vapor Pressure (Metric) – CFC-114 and CFC-502.....	22
TABLE 15 - Compressor Replacement Parts – Model CFC-1000	34
TABLE 16 - Compressor Torque Specifications – Model CFC-1000	35
TABLE 17 - Compressor Piston Selective Fits.....	35
TABLE 18 - Torque Values for Model 16799 Compressor	36
TABLE 19 - Compressor Replacement Parts – Discontinued Model 16799.....	38
TABLE 20 - Model D799 Compressor Parts (Old Style)	39
TABLE 21 - Compressor Three Cylinder Model RA & CK – BM-99301, -99302 & -99303	41
TABLE 22 - Vacuum Pump Replacement Parts – Model CRR-1	44
TABLE 23 - Compressor Parts – 51VSM.....	49
TABLE 24 - Compressor Refrigerating Capacity – 51VSM: R134a, BTU/HR.....	51
TABLE 25 - Compressor Refrigerating Capacity – 51VSM: R22, BTU/HR.....	51
TABLE 26 - Compressor Cross Reference Chart – 51VSM	52
TABLE 27 - Compressor Specifications – 51VSM.....	52
TABLE 28 - SI Metric Conversion	53

SECTION 1 - INTRODUCTION

The YORK Refrigerant Recovery and Recycling units are designed to handle all of the major refrigerants used in air conditioning and refrigeration units. These include R-11, R-114, R-123, R-12, R-134a, R-500, R-502 and R-22.

Refrigerant storage vessels are of a low pressure design for R-11, R-114 and R-123 and a high pressure design for the remaining refrigerants.

Two styles of units are available. One is a self contained "RSR"; the other is a combination of a "Portable Recovery Pak" – complete with controls – that is used in combination with an "Easy Tank" storage vessel complete with pressure safety controls and liquid float switch.

INSPECTION – DAMAGE – SHORTAGE

The unit shipment should be checked on arrival to see that all major pieces, boxes and crates are received. The unit should be checked on the trailer or rail car when received, before unloading, for visible signs of damage. Any damage or signs of possible damage should be reported to the transportation company immediately for their inspection. Also advise the Johnson Controls Regional or District Office so a Johnson Controls representative can assist in filing damage claims. **JOHNSON CONTROLS WILL NOT BE RESPONSIBLE FOR ANY DAMAGE IN SHIPMENT, OR AT JOB SITE, OR LOSS OF PARTS.**

If damage is found, Johnson Controls must be notified and action must be taken to prevent further damage or deterioration of the machinery, i.e.: a slow refrigerant leak exposure of internal parts to atmosphere, etc.

When received at the job site, all containers should be opened and contents checked against the packing list. Any material shortage should be reported to Johnson Controls immediately. (Refer to Shipping Damage Claims, Form 50.15-NM.)

SAFETY SUMMARY

Installation and servicing of air conditioning equipment and support equipment can be hazardous because of system pressures and the presence of dangerous voltages. Only trained and qualified service personnel should install, repair, or service such equipment.

- When using or servicing RSR units, observe precautions in the literature, as well as those on tags and labels attached to the equipment.
- Follow all safety codes. Wear glasses and work gloves when handling refrigerants.
- Before performing service or maintenance operations on this unit, turn off main power switch and disconnect power cord. Electrical shock could cause personal injury.
- Only the storage cylinder, interconnecting hose set, and filter-driers supplied with the RST unit may be used for hookup. Use of unspecified equipment could result in operator injury and/or release of refrigerant to the atmosphere.
- Avoid using an extension cord because the extension cord may overheat. If it is necessary to use an extension cord, the cord shall be #10 AWG minimum.
- Do not use this equipment near spilled or open containers of gasoline or other flammable products.
- This equipment should be used in a location with mechanical ventilation that provides at least four (4) air changes per hour.

To avoid damaging the unit or the environment:

- The unit must be operated with the storage cylinder connected and valves fully open.
- Use only the hoses supplied with the unit.
- Shut off the filter-drier valves before removing the filter drier.

MECHANICAL SPECIFICATIONS – RSR MODELS

The YORK Refrigerant/Recycling System is a self-contained package consisting of a refrigerant compressor or vacuum pump, with oil separator, storage receiver, heater, water-cooled condenser, filter drier and necessary valves and hoses to remove, replace and distill CFC and HCFC Refrigerants. All necessary controls and safety devices are a permanent part of the system. The complete system is portable, being mounted on swivel casters with lock brakes.

Refrigerant Compressor (High Pressure Units)

The high pressure units for refrigerants CFC-12, HCFC-22, CFC-500, CFC-502 and HFC-134a feature a reciprocating compressor that is capable of pulling a vacuum to a level which is in accordance with EPA requirements (See *Table 7 on page 17*).

Refrigerant Vacuum Pump

The low pressure units for refrigerants CFC-11, HFC-123 and CFC-114 utilize a vacuum pump to achieve the vacuum levels required by the EPA.

The term compressor will be used synonymously with vacuum pump throughout this document except where specific references are necessary.

Oil Separator And Heater

Oil separator includes drain valve and 25 watt heater.

Storage Receiver

Several storage receiver sizes are available (See *Table 1 on page 9*). The vessel is a horizontal type with two sight glasses installed to check liquid level. The receiver is designed and stamped in accordance with the ASME Boiler and Pressure Vessel Code. The vessel is pitched toward the receiver drain to allow total removal of liquid.

Valves And Hoses

The unit has permanent-mounted ball valves to allow the unit to remove, replace, or distill refrigerant without having to break hoses to the chiller. Eight feet of heavy duty refrigerant hoses with flare fittings are included to allow connection to the chiller.

Heater (CFC-11, CFC-114 And HCFC-123 Only)

The unit has a 1000-watt heater designed for 115V-1 - 50/60 power and capable of separating oil from refrigerant to less than 1000 ppm oil.

Condenser

The water-cooled condenser is a tube-in-tube design. The condenser is permanently mounted with refrigerant lines piped to the system. 3/4-inch hose bib connections are provided for field connection to the water supply.

STORAGE RECEIVER

The receivers are ASME certified. Each contains inlet and outlet valves and connections.

Safety Devices

A high-pressure switch is installed to protect the receiver and compressor against over pressurization. The relief device is per ASME specifications. Float switch cuts unit off when tank is 80% full of liquid refrigerant.

Filter Drier

The filter drier is permanently mounted on the system so that all gas entering or leaving the receiver will be filtered. The filter is a replaceable core type, capable of removing moisture to less than 50 ppm.

Controls

Mounted toggle switches are used to operate the unit and permit all safety devices to protect it.

Gauges

Unit-mounted gauges allow the technician to monitor suction and discharge pressure of the RSR system.

TABLE 1 - RSR SPECIFICATIONS – STANDARD

DESCRIPTION	MODEL							
	RSR-1100V		RSR-1600V		RSR-1100V114		RSR-1600V114	
Refrigerant	CFC-11		CFC-11		CFC-114		CFC-114	
	HCFC-123		HCFC-123					
Refrigerant Storage Capacity (Lbs.): 80% Full at 90° F	Refrigerant	Lbs	Refrigerant	Lbs	Refrigerant	Lbs	Refrigerant	Lbs
	CFC-11	1053	CFC-11	1500	CFC-114	1053	CFC-114	1500
	HCFC-123	1053	HCFC-123	1500			CFC-114	1500
Working Pressure (PSI)	50		50		50		50	
Horsepower	1		1		2		2	
Standard Voltages	115V-1-60		115V-1-60		115V-1-60		115V-1-60	
	208V-1-60		208V-1-60		208V-1-60		208V-1-60	
	230V-1-60		230V-1-60		230V-1-60		230V-1-60	
Plugs Included	Yes		Yes		Yes		Yes	
Weight (Lbs.)	700		850		700		850	
L x W x H (Inches)	61 x 24 x 53		84 x 24 x 53		61 x 24 x 53		84 x 24 x 53	
Wheels Included	Yes		Yes		Yes		Yes	
Relief Valves	(2) 1-1/4" FNPT		(2) 1-1/4" FNPT		(2) 1-1/4" FNPT		(2) 1-1/4" FNPT	
ASME Approved	Yes		Yes		Yes		Yes	

DESCRIPTION	MODEL							
	RSR-2212		RSR-2222		RSR-4436		RSR-4445	
Refrigerant	CFC-12, 500 & 502		CFC-12, 500 & 502		CFC-12, 500 & 502		CFC-12, 500 & 502	
	HCFC-22		HCFC-22		HCFC-22		HCFC-22	
	HFC-134a		HFC-134a		HFC-134a		HFC-134a	
Refrigerant Storage Capacity (Lbs.) 80% Full at 90°F	Refrigerant	Lbs	Refrigerant	Lbs	Refrigerant	Lbs	Refrigerant	Lbs
	CFC-12	1240	CFC-12	2166	CFC-12	3976	CFC-12	5684
	HCFC-22	1126	HCFC-22	1966	HCFC-22	3612	HCFC-22	4582
	CFC-500	970	CFC-500	1937	CFC-500	3503	CFC-500	4386
	CFC-502	1170	CFC-502	2044	CFC-502	3752	CFC-502	4630
	HFC-134a	1140	HFC-134a	1992	HFC-134a	3657	HFC-134a	4635
Working Pressure (PSI)	50		300		300		300	
Horsepower	1-1/2		1-1/2		10		10	
Standard Voltages	115V-1-60		115V-1-60		460V-3-60		460V-3-60	
	208V-1-60		208V-1-60					
	230V-1-60		230V-1-60					
Plugs Included	Yes		Yes		4 Prong		4 Prong	
Weight (Lbs.)	1325		1600		3200		4200	
L x W x H* (Inches)	84 x 24 x 53-1/8		93-1/4 x 30 x 60-1/8		119 x 36 x 77		112 x 42 x 90	
Wheels Included	Yes		Yes		Optional		Optional	
Relief Valves	(2) 5/8" Flare		(2) 3/4" FNPT		(2) 1" FNPT		(2) 1" FNPT	
ASME Approved	Yes		Yes		Yes		Yes	

*Wheels add 13" to overall height dimension of RSR-4436 and 4445

TABLE 2 - RSR SPECIFICATIONS – METRIC

DESCRIPTION	MODEL							
	RSR-1100V		RSR-1600V		RSR-1100V114		RSR-1600V114	
Refrigerant	CFC-11		CFC-11		CFC-114		CFC-114	
	HCFC-123		HCFC-123					
Refrigerant Storage Capacity (kg) 80% Full at 32° C	Refrigerant	kg	Refrigerant	kg	Refrigerant	kg	Refrigerant	kg
	CFC-11	478	CFC-11	680	CFC-114	478	CFC-114	680
	HCFC-123	478	HCFC-123	680				
Working Pressure (kPA)	345		345		345		345	
Kilowatts	0.75		0.75		1.5		1.5	
Standard Voltages	115V-1-60		115V-1-60		115V-1-60		115V-1-60	
	208V-1-60		208V-1-60		208V-1-60		208V-1-60	
	230V-1-60		230V-1-60		230V-1-60		230V-1-60	
Plugs Included	Yes		Yes		Yes		Yes	
Weight (kg)	318		386		318		386	
L x W x H (mm)	1549 x 609 x 1386		2134 x 609 x 1346		1549 x 609 x 1346		2134 x 609 x 1346	
Wheels Included	Yes		Yes		Yes		Yes	
Relief Valves	(2) 1-1/4" FNPT		(2) 1-1/4" FNPT		(2) 1-1/4" FNPT		(2) 1-1/4" FNPT	
ASME Approved	Yes		Yes		Yes		Yes	

DESCRIPTION	MODEL							
	RSR-2212		RSR-2222		RSR-4436		RSR-4445	
Refrigerant	CFC-12, 500 & 502		CFC-12, 500 & 502		CFC-12, 500 & 502		CFC-12, 500 & 502	
	HCFC-22		HCFC-22		HCFC-22		HCFC-22	
	HFC-134a		HFC-134a		HFC-134a		HFC-134a	
Refrigerant Storage Capacity (kg): 80% Full at 32°C	Refrigerant	kg	Refrigerant	kg	Refrigerant	kg	Refrigerant	kg
	CFC-12	562	CFC-12	992	CFC-12	1804	CFC-12	2265
	HCFC-22	511	HCFC-22	900	HCFC-22	1638	HCFC-22	2057
	CFC-500	440	CFC-500	878	CFC-500	1589	CFC-500	1995
	CFC-502	531	CFC-502	927	CFC-502	1702	CFC-502	2137
HFC-134a	517	HFC-134a	903	HFC-134a	1659	HFC-134a	2082	
Working Pressure (kPA)	345		2069		2069		2069	
Kilowatts	1.1		1.1		7.5		7.5	
Standard Voltages	115V-1-60		115V-1-60		460V-3-60		460V-3-60	
	208V-1-60		208V-1-60					
	230V-1-60		230V-1-60					
Plugs Included	Yes		Yes		4 Prong		4 Prong	
Weight (kg)	601		726		1452		1905	
L x W x H* (mm)	2134 x 609 x 1349		2368 x 762 x 1527		3022 x 914 x 1956		2845 x 1067 x 2286	
Wheels Included	Yes		Yes		Optional		Optional	
Relief Valves	(2) 5/8" Flare		(2) 3/4" FNPT		(2) 1" FNPT		(2) 1" FNPT	
ASME Approved	Yes		Yes		Yes		Yes	

*Wheels add 330 mm to overall height dimension of RSR-4436 and 4445.

MECHANICAL SPECIFICATIONS – PORTABLE RECOVERY PAK™

Valves and Hoses

The unit includes one input/one output refrigerant valves, and two refrigerant hoses, 8' long.

Filter

It includes replaceable, catch-all type filters with singlecore, 48 cubic inches (786 ccm).

Refrigerant Compressor (High Pressure Units)

The high pressure units for refrigerants CFC-12, HCFC-22, CFC-500, CFC-502 and HFC-134a feature a reciprocating compressor that is capable of pulling a vacuum to a level which is in accordance with EPA regulations. (See *Table 7 on page 17.*)

Refrigerant Vacuum Pump

The low pressure units for refrigerants CFC-11, HFC-123 and CFC-114 utilize a vacuum pump to achieve the vacuum levels required by the EPA.

The term compressor will be used synonymously with vacuum pump throughout this document except where specific references are necessary.

Condenser

The water-cooled condenser is a tube-in-tube design.

The condenser is permanently mounted with refrigerant lines piped to the system. 3/4-inch hose bib connections are provided for field connection to the water supply.

Oil Separator and Heater

Oil separator includes a drain valve and 25 watt heater.

Controls

An on/off switch; electrical cord and plug are provided.

Safeties

Unit safeties include high pressure cutoff (adjustable), and vacuum cutoff (adjustable). With a YORK refrigerant EasyTank™, integral safeties include heater cutoff (low pressure tanks only) pressure relief valve and a liquid level switch. The pressure relief valves meet ASME specifications.

Tanks

Nine standard EasyTank™ receivers are available, from 191 to 4895 pound capacities, plus custom designed receivers from 50 pound capacity and up.

Features

The unit has a solid frame construction. The unit is equipped with four heavy duty wheels for mobility.

The size and shipping weights are provided in *Table 3 on page 11.*

TABLE 3 - RECOVERY PAK SPECIFICATIONS (STANDARD AND METRIC)

DESCRIPTION		MODEL			
		RP-1000V	RP-114V	RP-2200	RP-4400
Refrigerant		CFC-11	CF-114	CFC-12, 500 & 502	CFC-12, 500 & 502
		HCFC-123		HCFC-22	HCFC-22
				HFC-134a	HFC-134a
Working Pressure	PSIG	50	50	300	300
	kPA	345	345	2069	2069
Power	HP	1	2	1-1/2	10
	KW	0.75	1.5	1.1	7.5
Standard Voltages		115V-1-60	115V-1-60	115V-1-60	460V-3-60
		208V-1-60	208V-1-60	208V-1-60	
		230V-1-60	230V-1-60	230V-1-60	
Plugs Included		Yes	Yes	Yes	4 Prong
Weight	Lbs	225	225	150	850
	Kg	102	102	68	385
L x W x H	Inches	24 x 24 x 27	24 x 24 x 27	24 x 24 x 28	57 x 29 x 66
	mm	610 x 610 x 686	610 x 610 x 686	610 x 610 x 711	1448 x 737 x 1676
Wheels Included		Yes	Yes	Yes	Yes

Gauges

Unit mounted gauges allow the monitoring of the suction and discharge pressure of the RSR system.

MECHANICAL SPECIFICATIONS – EASY TANK™**Safeties**

Low-pressure tanks use heater cutoff, pressure relief valve and refrigerant level safeties. High-pressure tanks use relief valves and liquid level safeties*. *Float switch shuts off recovery unit when tank becomes 80% full of liquid refrigerant.

Rating

The tanks are ASME certified. All tanks contain inlet and outlet valves and connections (See *Table 4 on page 12*).

Gauges

Sight glasses and pressure gauges are included.

Wheels

Standard wheels are included for tanks under 3000 pounds (1361 kg); custom wheels available for larger sizes.

Custom Tanks

Custom-made tanks are also available from 50 pounds (22.7 kg) storage capacity to as large as required for both high and low pressure refrigerants. Custom components, controls, safeties, and wheels are available.

Optional Clean Out Port

An ASME coded access port may be added as an option. The port opening is approximately 11" x 19" (279 mm x 482 mm).

TABLE 4 - STANDARD TANK OPTIONS (STANDARD AND METRIC)

MODEL	REFRIGERANT	REFRIGERANT STORAGE CAPACITY: 80% FULL AT 90°F (32°C)		DIAMETER X LENGTH		APPROXIMATE SHIPPING WEIGHT	
		LBS.	KG	INCHES	MM	LBS.	KG
RT-191 RT-300 RT-600 RT-1100 RT-1600 RT-2212	HCFC-22	191	86.7	14-3/4 x 49	375 x 1245	68	31
	CFC-11 & 114, HFC-123	600	272	20 x 52	508 x 1321	210	95
	CFC-11 & 114, HCFC-123	1053	478	24 x 61	609 x 550	410	186
	CFC-11 & 114, HCFC-123	1500	680	24 x 84	609 x 2134	460	209
	CFC-12	1240	563	24 x 84	609 x 2134	1000	454
	HCFC-22	1126	510	24 x 84	609 x 2134	1000	454
	CFC-500	970	440	24 x 84	609 x 2134	1000	454
	CFC-502	1170	530	24 x 84	609 x 2134	1000	454
	HFC-134a	1140	517	24 x 84	609 x 2134	1000	454
RT-2222	CFC-12	2166	982	30 x 93-1/4	702 x 2368	1300	590
	HCFC-22	1966	906	30 x 93-1/4	702 x 2368	1300	590
	CFC-500	1937	879	30 x 93-1/4	702 x 2368	1300	590
	CFC-502	2044	928	30 x 93-1/4	702 x 2368	1300	590
	HFC-134a	1992	904	30 x 93-1/4	702 x 2368	1300	590
RT-4436	CFC-12	3976	1804	36 x 119	914 x 3022	2700	1225
	HCFC-22	3612	1639	36 x 119	914 x 3022	2700	1225
	CFC-500	3503	1590	36 x 119	914 x 3022	2700	1225
	CFC-502	3752	1702	36 x 119	914 x 3022	2700	1225
	HFC-134a	3652	1748	36 x 119	914 x 3022	2700	1225
RT-4445	CFC-12	4993	2265	42 x 112	1067 x 2845	3620	1642
	HCFC-22	4535	2057	42 x 112	1067 x 2845	3620	1642
	CFC-500	4399	1995	42 x 112	1067 x 2845	3620	1642
	CFC-502	4712	2137	42 x 112	1067 x 2845	3620	1642
	HFC-134a	4591	2082	42 x 112	1067 x 2845	3620	1642

SECTION 2 - OPERATION

GENERAL

The function of a Refrigerant Recovery/Recycling Unit (RSR) is to remove and store refrigerant from any machine using the refrigeration cycle and CFC or HCFC refrigerants. The refrigerants must be removed from the refrigerant circuit before opening any part of the unit for maintenance or repairs. Federal law prohibits the venting of refrigerant to the atmosphere.

The RSR is connected to the refrigeration unit by means of hoses supplied with the RSR. The RSR compressor develops a pressure differential between the RSR and the refrigeration unit so that liquid refrigerant is forced into a storage vessel used in conjunction with the RSR.

The RSR is equipped with a water cooled condenser that is used to condense the refrigerant vapor remaining in the refrigeration unit after the liquid refrigerant has been removed. For this duty, the RSR compressor pumps the remaining vapor through the condenser and the resulting liquid refrigerant flows into the storage vessel.

After the refrigeration unit has been repaired, the process is reversed so that refrigerant is pumped back into the refrigeration unit.

PRIOR TO STARTING REFRIGERANT RECOVERY

Set Pressure Safety Control

A high/low pressure safety control is wired in the motor control circuit. The pressure settings are adjustable to conform to the design working pressure of the RSR storage vessel and the upper limit for satisfactory

performance of the RSR condenser and compressor for the refrigerant being recovered.

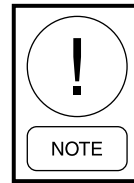

Prior to starting the RSR unit, the pressure control must be set to the high and low pressure values shown in Table 5 on page 13.

Check Oil Level

RSR Compressor (High Pressure Units)

The oil level should be checked in the sight glass located in the RSR compressor crankcase.



A shortage of oil will result in the failure of the RSR compressor.

The oil level should be 1/2 to 3/4 from the bottom of the sight glass when the RSR compressor is not running.

All units, Except where Refrigerant 134a is used, come factory charged with YORK Type "C" oil. Only this type of oil should be used when adding oil with the exception where R-134a is used in the refrigeration unit. The Ester based oil is used in conjunction with R-134a. Consult the manufacturer's recommendations for oil to be used in the RSR compressor if R-134a is used in the refrigeration system.

It is recommended that an RSR unit be dedicated for use in recovering only R-134a. Otherwise the oil in

TABLE 5 - SETTINGS FOR PRESSURE SAFETY CONTROL SWITCHES

REFRIGERANT	CUT OUT				CUT IN		
	HIGH PRESSURE		LOW PRESSURE		HIGH PRESSURE	LOW PRESSURE	
	PSIG	KPA	IN HG	KPA	PSIG	IN HG	KPA
CFC-12/HFC-134a	150	1034	20	68	Manual Reset	10	34
CFC-500	180	1241	20	68	Manual Reset	10	34
CFC-502	250	1724	20	68	Manual Reset	10	34
HCFC-22	250	1724	20	68	Manual Reset	10	34
CFC-11/HFC-123	10	69	29	98	Manual Reset	20	68
CFC-114	30	207	29	98	Manual Reset	20	68

the RSR compressor and oil separator will have to be changed when changing from other refrigerants to R-134a and when changing back from R-134a to other refrigerants.

See the *SECTION 4 - MAINTENANCE PROCEDURES* of this manual for the correct procedure for adding and removing oil from the RSR unit compressor and oil separator.

Check Oil Level in Vacuum Pump (Low Pressure Units)

The oil level in the vacuum pump should be at the midpoint of the oil level window.

Unlike the high pressure units, the oil in the vacuum pump is not the same as that used in the refrigeration unit being serviced. A special vacuum pump oil must be used.

Vacuum pumps are tested with DuoSeal® brand oil and shipped with a full charge to prevent unnecessary contamination. The oil acts both as a lubricant and the vacuum seal between the rotating components. An additional supply of oil is furnished with each pump with instructions to drain and discard the oil, when it becomes contaminated, and replace with the fresh oil. DuoSeal oil has been especially prepared and is ideally suited for use in vacuum pumps because of its desirable viscosity, low vapor pressure and chemical stability. The vacuum guarantee on all pumps applies only when DuoSeal oil is used.

Oil Contamination

The most common cause of a loss in efficiency in a vacuum pump is contamination of oil. It is caused by condensation of vapors and by foreign particles. The undesirable condensate emulsifies with the oil which is recirculated and subjected to re-evaporation during the normal cycle of pump activity thus reducing the ultimate vacuum attainable. Some foreign particles and vapors may form sludges with the oil, impair sealing and lubrication and cause eventual seizure. Periodic oil changes are necessary to maintain efficient operation of the system. The required frequency of changes will vary with the particular system. Experience with the process will help you determine the normal period of operation before an oil change is required.

See *SECTION 4 - MAINTENANCE PROCEDURES* for Low Pressure Units for the correct procedure to add or remove oil from the vacuum pump and oil separator.

Filter Dryer Replacement Element

The RSR unit contains a filter dryer that removes moisture, acids, as well as solid particles from the refrigerant that is being recovered. The filter dryer contains a removable element (Sporlan #RC 4864) that must be in place before the unit is used.

The filter/dryer element must also be changed when:

1. Changing the type of refrigerant being recovered.
2. When the liquid sight glass indicator shows that excessive moisture is in the refrigerant.
3. After recovering refrigerant from a refrigeration unit that has had a motor burnout.
4. After the RSR unit has been run for 100 hours.

If the refrigeration unit, from which the refrigerant is being recovered, has experienced a hermetic compressor motor burn out, or if the liquid sight glass/moisture indicator shows excessive moisture in the refrigerant, a filter/dryer (Sporlan C-415) should be inserted at the end of the RSR liquid refrigerant hose, where it connects to the refrigeration unit liquid connection.

Before the refrigeration unit is recharged, the valve at the end of the liquid hose and on the refrigeration unit (at the opposite end of the filter dryer) should be closed. Remove the filter dryer and replace it with a new filter dryer with the arrow pointing in the direction of the refrigeration unit.

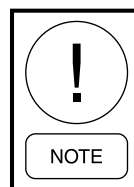

The arrow indicating direction of flow should point toward the RSR unit when liquid refrigerant moves from the refrigeration unit to the RSR storage vessel.

See *SECTION 4 - MAINTENANCE PROCEDURES* for specific instructions for changing the filter/dryer element.

Connecting Hoses

The refrigerant hoses, furnished with the RSR unit, are connected to the evaporator and condenser of the refrigeration unit as shown in the schematic diagram shown in *Figure 1 on page 15*. A third hose, used with the portable unit only, is connected between the valve on the top of the storage vessel and the refrigerant connection on the condenser of the portable RSR unit.

Only the dedicated storage vessel and interconnecting hose set supplied with the RSR unit can be used for the hookup.



Use of Unspecified Equipment Could Result in Personal Injury and Release of Refrigerant to the Atmosphere.

When using the Portable Recovery Pak, it is mandatory that the EasyTank™, manufactured by Johnson Controls, be used as the storage vessel. These contain the proper pressure relief valves, liquid level float switch and matching interconnecting wiring for the safety switches. In order for the Portable Recovery Pak to operate, the interconnecting safety wiring must be plugged into the matching socket.

Shipping Charge

When the unit is shipped from the factory, a holding charge of dry nitrogen is placed in the storage vessel under a pressure of approximately 5 psig. Prior to first using the RSR unit, the pressure should be relieved to the atmosphere and the vessel evacuated with a vacuum pump to a vacuum of 29 inches of mercury. Evacuate using gas connection (connection between valves 1 & 2), open valves 1, 2, 3, & 4 during evacuation – close valve 5. (See Figure 1 on page 15)

OPERATION OF REFRIGERANT STORAGE/ RECYCLE SYSTEM

Liquid Transfer – Refrigeration Unit to RSR Storage Vehicle

This method is recommended for the initial phase of refrigerant recovery. (See Figure 1 on page 15)

To bleed air from the connecting liquid refrigerant hose:

1. With valve 5 closed, crack valve 6 at the evaporator.
2. Slowly open refrigerant hose connection at 5 until a very small amount of refrigerant exists at the hose connection. (Make sure unit is above 0 psig – if not, do not use this step.)
3. Retighten hose fitting at valve 5.

To bleed air from the remaining refrigerant hose:

1. Close valves 1 and 2.
2. Crack valve 7.
3. Bleed refrigerant from hose connection at manifold and retighten hose fitting as above. (Make sure unit is above 0 psig – if not, do not use this step.)

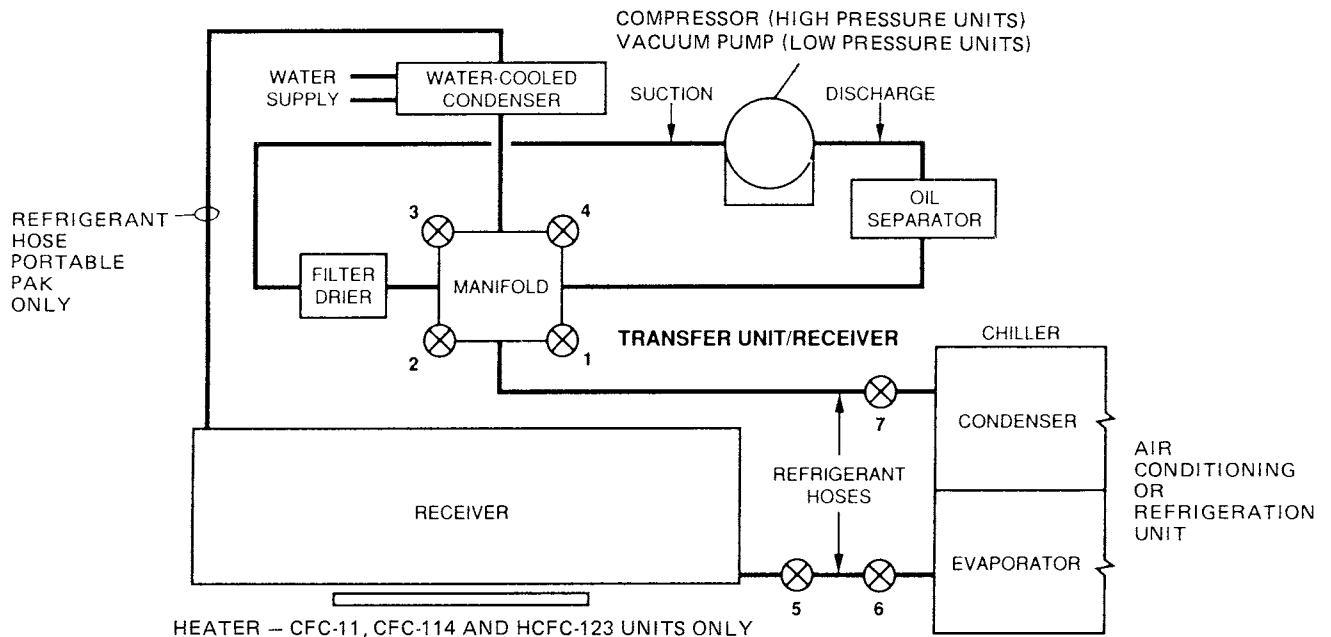

LD01105

FIGURE 1 - YORK RSR SYSTEM FLOW DIAGRAM

Set the valves and pumps as shown in the first column of *Table 6 on page 16*. Start the RSR unit by switching the toggle switch on the control box to the ON position.

When the RSR unit is started, the compressor reduces the pressure in the storage vessel. The discharge side of the compressor pressurizes the refrigeration unit through the connection to the condenser. The resulting pressure differential forces the liquid refrigerant from the refrigeration unit into the RSR storage vessel.

The transfer of liquid is complete when the level in the RSR storage vessel, as observed through the sight glasses, ceases to rise. Close valve 5 and move the RSR toggle switch to the OFF position. Proceed to the Gas Pump Out.

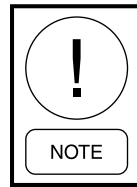

When first starting the vacuum pump on a low pressure system, the suction valve on the pump should remain closed until the pump comes up to operating temperature. If refrigerant vapor is pumped through the pump before the pump is warmed up, a large quantity of refrigerant will dissolve in the oil. The dissolved refrigerant will superheat and boil off violently as the pump approaches its operating temperature. Excessive oil loss will result. Intake valve should be opened gradually to prevent sudden refrigerant rush to the pump and loss of oil from the pump.

The vacuum pump should never be exposed to a discharge pressure higher than 30 PSIG.

TABLE 6 - OPERATION SETTINGS

CONTROL	1	2	3	4		5
	TO REMOVE LIQUID FROM CHILLER	TO REMOVE GAS FROM CHILLER	TO REMOVE OIL FROM REFRIGERANT	TO RECHARGE CHILLER		
				STEP 1 – GAS OFF		STEP 2 – LIQUID CHARGE
RSR SYSTEM						
Valve 1	Open	Closed	Open	Open	1 & 4 or 2 & 3	Closed
Valve 2	Closed	Open	Closed			Open
Valve 3	Open	Closed	Open			Closed
Valve 4	Closed	Open	Closed			Open
Valve 5	Open	Closed	Closed	Closed		Open
Compressor	On	On	On	Off		On
Water to Condenser	Off	On	Off	Off		On
Heater	Off	Off	On	Off		On
CHILLER/AIR CONDITIONER						
Valve 6	Open	Closed	Closed	Closed		Open
Valve 7	Open	Open	Open	Open		Open
Chiller Water Pump	Off	On	On	Either One	On	On
Condenser Water Pump	Off	Off	On		On	On

Gas Pump Out – Refrigeration Unit To Rsr Storage Vessel

After the liquid refrigerant has been removed from the refrigeration unit, as previously described, the following procedure is used to remove the remaining refrigerant gas.

Set the valves and pumps as shown in column 2 of *Table 6 on page 16*. Start the RSR unit by turning the toggle switch to the ON position.

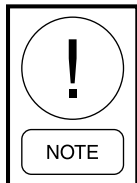

On units RSR-2212, RSR-2222 and RP-2200 close compressor suction service valve so that suction pressure does not exceed 70 psig.

The RSR unit draws refrigerant vapor from the refrigeration unit and condenses same in the RSR water cooled condenser. The liquefied refrigerant flows to RSR storage vessel.

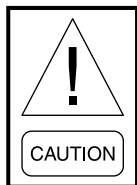

WHEN EVACUATING REFRIGERATION UNITS WITH LIQUID CHILLER AND/OR WATER COOLED CONDENSERS — During the pumpout procedure, while any remaining liquid refrigerant is in contact with unit water tubes, care must be taken to prevent the unit saturation pressure/temperature from dropping below the freezing temperature of the water or brine.

The operation should continue until a vacuum of the value shown in *Table 6 on page 16* exists for the specified type of refrigeration unit being evacuated.

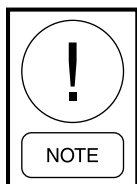

During the evacuation process, valve 6 should remain open to evacuate the refrigerant hose between valves 6 and 5. When the system being evacuated reaches the aforementioned vacuum, valve 6 should be closed to seal off the hose. Valve 7 should be closed prior to turning the RSR unit off to evacuate the remaining refrigerant hose.

After the hoses have been evacuated and valves 6 and 7 closed, the RSR unit can be shut off but the hoses must remain in place. After a waiting period of 5 minutes, the pressure in the refrigeration unit is to be checked. If the pressure has risen due to residual refrigerant remaining in the refrigeration unit, the Gas Pump Out

procedure must be repeated until a pressure rise is not detected after a five minute waiting period.

TABLE 7 - FINAL VACUUM/EPA REGULATIONS

DESCRIPTION	FINAL VACUUM IN. HG (KPA)
HCFC-22 unit containing less than 200 Lbs. /91 kg of refrigerant	0 (0)
HCFC-22 unit containing more than 200 Lbs./91 kg of refrigerant	10 (33.9)
Other high pressure units containing less that 200 Lbs. /91kg of refrigerant	10 (33.9)
Other high pressure units containing more than 200 Lbs./91 kg of refrigerant	15 (51)
Low pressure units (CFC-11, HCFC-123 & CFC-114)	25* (98)

*=mm Hg absolute

DETECTION AND REMOVAL OF NON-CONDENSIBLE GASES

After the RSR unit containing the stored refrigerant has equalized such that the machine and stored refrigerant are at the same temperature as the surrounding ambient temperature, the refrigerant can be checked for non-condensable gases. If the pressure in the storage vessel, as read on the compressor discharge gauge, exceeds the saturation pressure of the refrigerant at the ambient temperature by the amount shown in *Table 8 on page 18*, there is a need to vent the non-condensable gases from the Schraeder type valve located on the top of the storage vessel for a period of fifteen seconds. The procedure should be repeated until the saturation pressure in the storage vessel is within the pressure range shown in *Table 8 on page 18* for the given refrigerant. The storage vessel and contained refrigerant should be allowed to equalize to ambient temperature between ventings.

When the refrigerant in the storage vessel reaches a stable temperature – equal to the surrounding ambient air temperature – the pressure in the storage vessel, read on the compressor discharge gauge, should be the same as the saturation pressure for the ambient temperature. If the pressure reading is higher by the above values, or more, the storage vessel should be purged of non-condensable.

TABLE 8 - PRESSURE DIFFERENCE FOR DETERMINING PRESENCE OF NON-CONDENSIBLE GASES

REFRIGERANT	DIFFERENCE BETWEEN GAUGE READING AND SATURATED PRESSURE	
	PSIG	KPA
CFC-11	4	27.6
CFC-114	4	27.6
HFC-123	4	27.6
CFC-12	6	41.4
HFC-134a	6	41.4
CFC-500	8	55.1
HCFC-22	10	69.0
CFC-502	10	69.0

CHARGING REFRIGERATION UNIT WITH REFRIGERANT FROM RSR UNIT

Gas Charging

When it is time to transfer the refrigerant from the RSR to the refrigeration unit, the latter must first be charged with gas.

This is particularly true of refrigeration units containing liquid coolers and/or water cooled condensers. If liquid refrigerant is charged in the unit when the unit pressure is lower than the saturation pressure equivalent to 32°F (0°C), the water tubes can freeze and burst even though water is being pumped through the tubes.

Set the water flow and valves as shown in column 4 *Table 6 on page 16*. When the valves are set, refrigerant gas will flow into the refrigeration unit because of the higher pressure in the RSR. The RSR compressor does not have to run during gas charging.

When the refrigeration unit pressure is above the saturation pressure equivalent to 32°F (0°C) (*Table 8*) or when the pressure has equalized, close all of the valves.

On RSR Models 1100 and 1600 and on Easy Tank™ Models RT 1100 and 1600, an electric heater is installed on the bottom of the storage vessel to increase the pressure of the stored refrigerant when the RSR is subjected to low ambient temperatures.

Charging with Liquid Refrigerant

Set the valves and pumps as indicated in column 5 of *Table 6 on page 16*. Turn the toggle switch on the RSR to the ON position.

Refrigerant vapor will be pulled off of the top of the refrigeration unit condenser, raised to a higher pressure by the RSR compressor, condensed to liquid in the RSR condenser, and then returned to the refrigeration unit as a liquid.

The level of liquid in the storage vessel can be observed through the sight glasses in the vessel. When the liquid has been exhausted from the storage vessel, close valves 6 and 7 and simultaneously shut OFF the RSR toggle switch.

Removal of Refrigerant from Hoses and Storage Vessel

Before removing the hoses between the RSR and the refrigeration unit, open valves 1 and 3 on the manifold and close valves 2 and 4. Start the RSR compressor and open valve 7 simultaneously. Valve 5 should be open and valve 6 closed.

Run the RSR compressor until a vacuum of at least 29 in. Hg. exists in the storage vessel. At this point, close valve 7 and simultaneously move the RSR toggle switch to the OFF position. Close manifold valves 1, 2, 3, and 4, as well as valve 5. The hose valves can then be closed and the hoses removed from the refrigeration unit.

TABLE 9 - VAPOR PRESSURE – CFC-11, CFC-12, CFC-22 AND CFC-500

TEMP. (°F)	VAPOR PRESSURE*			
	CFC-11	CFC-12	CFC-22	CFC-500
-150	29.9	29.6	29.4	
-140	29.9	29.4	29.0	
-130	29.9	29.1	28.4	
-120	29.9	28.6	27.7	
-110	29.8	28.0	26.5	
-100	29.8	27.0	25.0	26.4
-90	29.7	25.7	23.0	24.9
-80	29.6	24.1	20.2	22.9
-70	29.4	21.8	16.6	20.3
-60	29.2	19.0	12.0	17.0
-50	28.9	15.4	6.2	12.8
-40	28.4	11.0	0.5	7.6
-35	28.1	8.4	2.6	4.6
-30	27.8	5.4	4.9	1.2
-25	27.4	2.3	7.4	1.2
-20	27.0	0.6	10.2	3.2
-15	26.5	2.4	13.2	5.4
-10	26.0	4.4	16.4	7.8
-5	25.4	6.7	20.1	10.4
0	24.7	9.2	24.0	13.3

TABLE 9 - VAPOR PRESSURE – CFC-11, CFC-12, CFC-22 AND CFC-500 (CONT'D)

TEMP. (°F)	VAPOR PRESSURE*			
	CFC-11	CFC-12	CFC-22	CFC-500
5	23.9	11.8	28.2	16.4
15	22.1	17.7	37.7	23.3
20	21.2	21.0	43.0	27.2
25	19.9	24.6	48.8	31.4
30	18.6	28.4	54.9	36.0
35	17.2	32.6	61.4	40.8
40	15.6	37.0	68.5	46.0
45	13.9	41.7	76.0	51.6
50	12.0	46.7	84.0	57.5
55	10.0	52.1	92.6	63.9
60	7.8	57.7	101.6	70.6
65	5.4	63.8	111.2	77.8
70	2.8	70.2	121.4	85.3
75	0.0	77.0	132.2	93.4
80	1.5	84.2	143.6	101.9
85	3.2	91.8	155.7	111.0
90	4.9	99.8	168.4	120.4
95	6.8	108.2	181.8	130.5
100	8.8	117.2	195.9	141.1
105	10.9	126.6	210.7	152.2
110	13.1	136.4	226.4	164.0
115	15.6	146.8	242.7	176.3
120	18.3	157.7	259.9	189.2
125	21.0	169.1	277.9	202.8
130	24.0	181.0	296.8	217.0
135	27.1	193.5	316.6	231.8
140	30.4	206.6	337.2	247.4
145	34.0	220.3	358.9	263.7
150	37.7	234.6	381.5	280.7

*Vapor pressures are shown as PSIG. Screened figures are shown as inches of mercury (HG) vacuum.

TABLE 10 - VAPOR PRESSURE – HCFC-123 AND HFC-134A

TEMP. (°F)	VAPOR PRESSURE (PSIG)*	
	HCFC-123	HFC-134A
-100	29.9	27.8
-90	29.8	26.9
-80	29.7	25.6
-70	29.6	23.8
-60	29.5	21.5
-50	29.2	18.5
-40	28.9	14.7
-30	28.5	9.8
-20	27.8	3.8
-10	27.0	1.8
0	26.0	6.3
10	24.7	11.6
20	23.0	18.0
30	20.8	25.6
40	18.2	34.5
50	15.0	44.9
60	11.2	56.9
70	6.6	70.7
80	1.1	86.4
90	2.6	104.2
100	6.3	124.3
110	10.5	146.8
120	15.4	171.9
130	21.0	199.8
140	27.3	230.5
150	34.5	264.4

*Vapor pressures are shown as PSIG. Screened figures are shown as inches of mercury vacuum.

TABLE 11 - VAPOR PRESSURE – CFC-114 AND CFC-502

TEMP. (°F)	VAPOR PRESSURE (PSIG)*	TEMP. (°F)	VAPOR PRESSURE (PSIG)*
	CFC-114		CFC-502
-100	29.523	-75	15.098
-80	28.994	-70	12.749
-60	27.955	-65	10.109
-40	26.073	-60	7.1539
-20	22.893	-55	3.8567
-15	21.829	-50	0.1906
-10	20.638	-49.75	0.0
-5	19.308	-48	0.6804
0	17.829	-46	1.4865
5	16.188	-44	2.3256
10	14.374	-42	3.1986
12	13.597	-40	4.1064
14	12.789	-38	5.0500
16	11.950	-36	6.0303
18	11.078	-34	7.0482
20	10.174	-32	8.1048
22	9.2348	-30	9.2010
24	8.2611	-28	10.338
26	7.2517	-26	11.516
28	6.2056	-24	12.737
30	5.1219	-22	14.001
32	3.9997	-20	15.310
34	2.8381	-18	16.665
36	1.6361	-16	18.066
38	0.3929	-14	19.515
38.62	0.0	-12	21.013
40	0.4384	-10	22.560
42	1.0909	-8	24.158
44	1.7652	-6	25.808
46	2.4615	-4	27.511
48	3.1805	-2	20.268
50	3.9226	0	31.080
52	4.6883	2	32.948
54	5.4781	4	34.873
56	6.2924	6	36.856
58	7.1318	8	38.898
60	7.9967	10	41.001
62	8.8877	15	46.530
64	9.8053	20	52.459
66	10.750	25	58.807
68	11.722	30	65.591

TABLE 11 - VAPOR PRESSURE – CFC-114 AND CFC-502 (CONT'D)

TEMP. (°F)	VAPOR PRESSURE (PSIG)*	TEMP. (°F)	VAPOR PRESSURE (PSIG)*
	CFC-114		CFC-502
70	12.722	35	72.827
72	13.751	40	80.533
74	14.809	45	88.726
76	15.897	50	97.425
78	17.014	55	106.65
85	21.172	60	116.41
90	24.384	65	126.73
95	27.808	70	137.63
100	31.452	75	149.12
105	35.325	80	161.23
110	39.436	85	173.97
120	48.407	90	187.36
130	58.438	95	201.43
140	69.603	100	216.20
150	81.982	105	231.68
		110	247.92
		115	264.92
		120	282.72
		125	301.35
		130	320.85
		135	341.25
		140	362.60
		145	384.95
		150	408.37

*Vapor pressures are shown as PSIG. Screened figures are shown as inches of mercury (HG) vacuum.

TABLE 12 - VAPOR PRESSURE (METRIC (KPA) – CFC-11, CFC-12, CFC-22 AND CFC-500

TEMP. (°C)	VAPOR PRESSURE (KPA)*			
	CFC-11	CFC-12	CFC-22	CFC-500
-101	101	100	100	
-95	101	100	98	
90	101	99	96	
-84	101	97	94	
-79	101	95	90	
-73	100	91	85	89
-67	100	87	78	84
-62	100	82	68	77
-56	99	74	56	68
-51	99	64	41	58
-46	98	52	21	43
-40	96	37	3.4	26
-37	95	28	17.9	16
-34	94	18	33.8	4
-31	93	7.8	51.0	4
-28	91	4.1	70.3	22.1
-26	90	16.5	91.0	37.2
-23	88	30.3	113.1	53.8
-21	86	46.2	138.6	71.7
-18	84	63.4	165.5	91.7
-15	81	81.4	194.4	113.1
-12	78	100.6	226.2	135.8
-9	75	122.0	259.9	160.7
-6	72	144.8	296.5	187.5
-4	67	170.0	336.5	216.5
-1.1	63	196	379	248
1.7	58	225	423	281
4.4	53	255	472	317
7.2	47	288	524	356
10.0	41	322	579	396
12.8	34	359	638	441
15.6	26	398	701	487
18.3	18	440	767	536
21.1	9	484	837	588
23.9	0	531	912	644
26.7	10	581	990	703
29.4	22	633	1074	765
32.2	34	688	1161	830
35.0	47	746	1254	900
37.8	61	808	1351	973
40.6	75	873	1453	1049
43.3	90	940	1561	1131
46.1	108	1012	1673	1216

TABLE 12 - VAPOR PRESSURE (METRIC (KPA) – CFC-11, CFC-12, CFC-22 AND CFC-500 (CONT'D)

TEMP. (°C)	VAPOR PRESSURE (KPA)*			
	CFC-11	CFC-12	CFC-22	CFC-500
51.7	145	1166	1916	1398
54.4	165	1248	2046	1496
57.2	187	1334	2183	1598
60.0	210	1425	2325	1706
62.8	234	1519	2475	1818
65.6	260	1618	2630	1935

*Vapor pressures are shown as kPa. Screened figures are shown as kPa of mercury vacuum.

TABLE 13 - VAPOR PRESSURE (METRIC) – HCFC-123 AND HFC-134A

TEMP. (°C)	VAPOR PRESSURE (KPA)*	
	HCFC-123	HFC-134A
-73.3	101	94
-67.8	101	91
-62.2	101	87
-56.7	100	81
-51.1	100	73
-45.6	99	63
-40.0	98	50
-34.4	97	33
-28.9	94	13
-23.3	91	12
-17.8	88	43
-12.2	84	80
-6.7	78	124
-1-1	70	177
4.4	62	238
10.0	51	310
15.6	38	392
21.1	22	487
26.7	4	596
32.2	18	718
37.8	43	857
43.3	72	1012
48.9	106	1185
54.4	145	1378
60.0	188	1589
65.6	300	1823

*Vapor pressures are shown as kPa. Screened figures are shown as kPa of mercury vacuum.

TABLE 14 - VAPOR PRESSURE (METRIC) – CFC-114 AND CFC-502

TEMP. (°C)	VAPOR PRESSURE (KPA)*	TEMP. (°C)	VAPOR PRESSURE (KPA)*
	CFC-114		CFC-502
-73.3	100	-59.4	51
-62.2	98	-56.7	43
-51.1	95	-53.9	34
-40.0	88	-51.1	24
-28.9	78	-48.3	13
-26.1	74	-45.6	1
-23.3	70	-45.4	0
-20.6	65	-44.4	0
-17.8	60	-43.3	10
-15.0	55	-42.2	16
-12.2	49	-41.1	22
-11.1	46	-40.0	28
-10.0	43	-38.9	35
-8.9	40	-37.8	42
-7.8	38	-36.7	49
-6.7	34	-35.6	56
-5.6	31	-34.4	63
-4.4	28	-33.3	71
-3.3	25	-32.2	79
-2.2	21	-31.1	88
-1.1	17	-30.0	97
0.0	14	-28.9	106
1.1	10	-27.8	115
2.2	6	-26.7	125
3.3	1	-25.6	135
3.7	0	-24.4	145
4.4	3.3	-23.3	156
5.6	7.5	-22.2	167
6.7	12.2	-21.1	178
7.8	17.0	-20.0	190
8.9	21.9	-18.9	202
10.0	27.0	-17.8	214
11.1	32.3	-16.7	227
12.2	37.8	-15.6	240
13.3	43.4	-14.4	254
14.4	49.2	-13.3	268
15.6	55.1	-12.2	283
16.7	47.5	-9.4	321
17.8	67.6	-6.7	362
18.9	74.1	-3.9	405

TABLE 14 - VAPOR PRESSURE (METRIC) – CFC-114 AND CFC-502 (CONT'D)

TEMP. (°C)	VAPOR PRESSURE (KPA)*	TEMP. (°C)	VAPOR PRESSURE (KPA)*
	CFC-114		CFC-502
20.0	80.8	-1.1	452
21.1	87.7	1.7	502
22.2	94.8	4.4	555
23.3	102.1	7.2	612
24.4	109.6	10	672
25.6	117.3	12.8	735
29.4	146.0	15.6	803
32.2	168.1	18.3	874
35.0	191.7	21.1	949
37.8	216.9	23.9	1028
40.6	243.6	26.7	1112
43.3	271.9	29.4	1200
48.9	333.8	32.2	1292
54.4	402.9	35.0	1389
60.0	479.9	37.8	1491
65.6	564.7	40.6	1597
		43.3	1709
		46.1	1827
		48.9	1949
		51.7	2078
		54.4	2212
		57.2	2353
		60.0	2500
		62.8	2654
		65.6	2816

*Vapor pressures are shown as kPa. Screened figures are shown as kPa of mercury (HG) vacuum.

SECTION 3 - DIAGRAMS

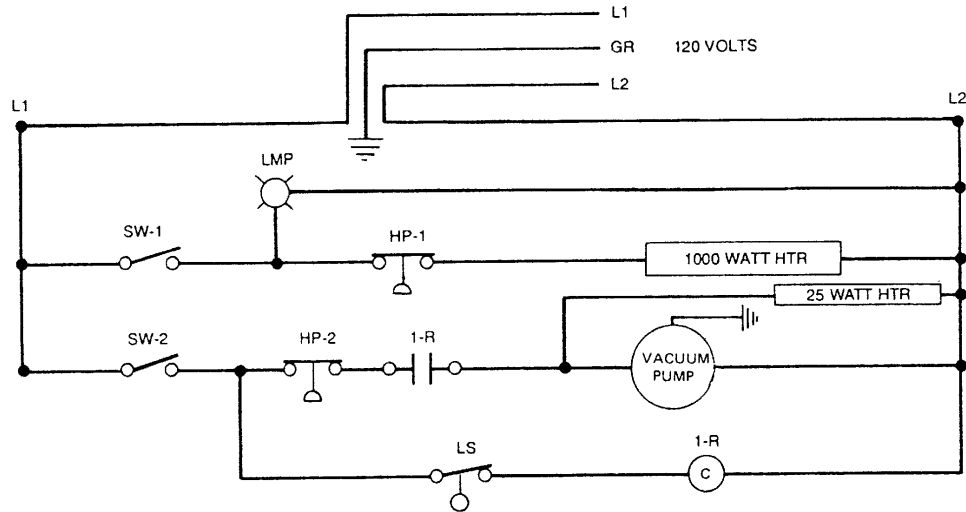

LEGEND	
SW-1	Switch, On-Off w/ Indicator Light (1000 Watt Heater)
SW-2	Switch, On-Off (Vacuum Pump)
HP	Contact, High Pressure
HTR	Heater, Refrigerant Storage Vessel (1000 Watt)
HTR	Heater, Oil Separator (25 Watt)
LS	Switch, Liquid Level
1-R	Relay, Liquid Level Switch, w/ N.O. contact

LD17563

FIGURE 2 - WIRING DIAGRAM RSR-1100V, -1600V, -1100V114, & -1600V114

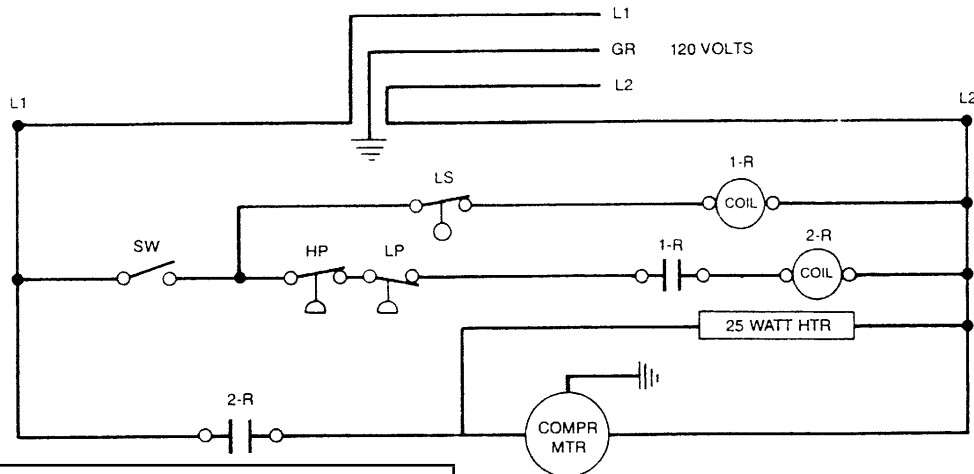

LEGEND	
SW	Switch, On-Off (Compressor Motor)
HP-LP	Switch, Pressure, Combination Hi-LO
LS	Switch, Liquid Level
1-R	Relay, Float Switch, N.O. contact
2-R	Relay, Motor Circuit, N.O. contact
HTR	Heater, Oil Separator

LD17564

FIGURE 3 - WIRING DIAGRAM RSR-2212 & -2222

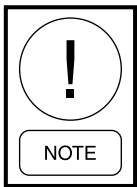
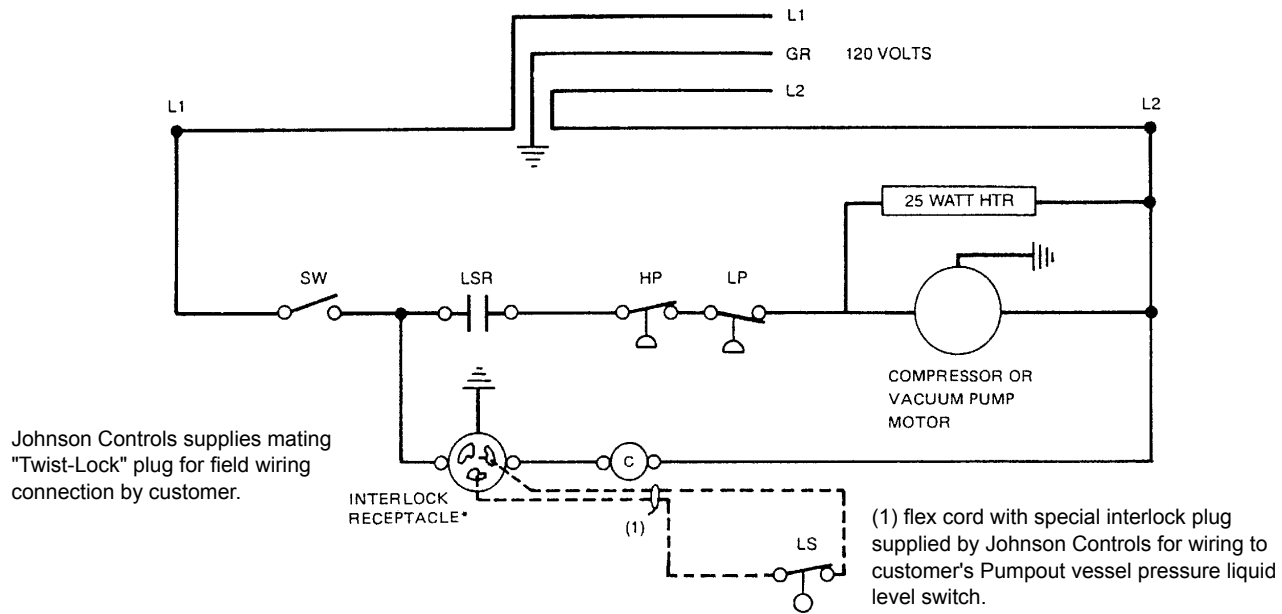

**Interlock Receptacle will not allow EASY-PAK Compressor to operate unless liquid level switch LS is in the electrical control circuit.*

Legend	
SW	Switch, On-Off, Motor
HP-LP	Switch, Pressure, Combination Hi-Lo Control
LS	Switch, Liquid Level
LSR	Relay, N.O. contact
HTR	Heater, Oil Separator (25 watt)

LD17565

FIGURE 4 - WIRING DIAGRAM EASY PAK RP-1000V, -114V & -2200

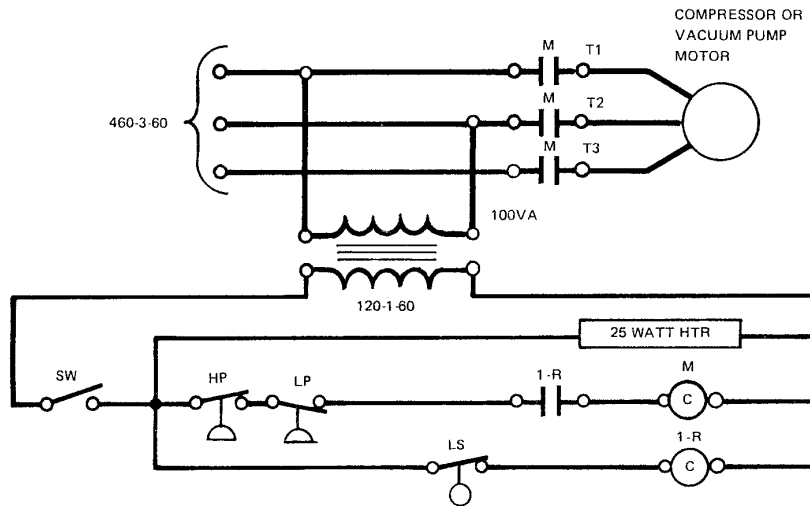

Easy-Pak Model RP-2400 is supplied with 8' flexible cord and interlocking plug for liquid level switch circuit on refrigerant storage tank.

Legend	
SW	Switch, On-Off (Compressor)
HP-LP	Switch, Pressure, Combination Hi-Lo Control
LS	Switch, Liquid Level
1-R	Relay, Liquid Level, N.O. contact
M	Contactor, Compressor Motor

LD17566

FIGURE 5 - WIRING DIAGRAM RSR-2240, -2250, -4436, -4445 & RP-2400, -3400

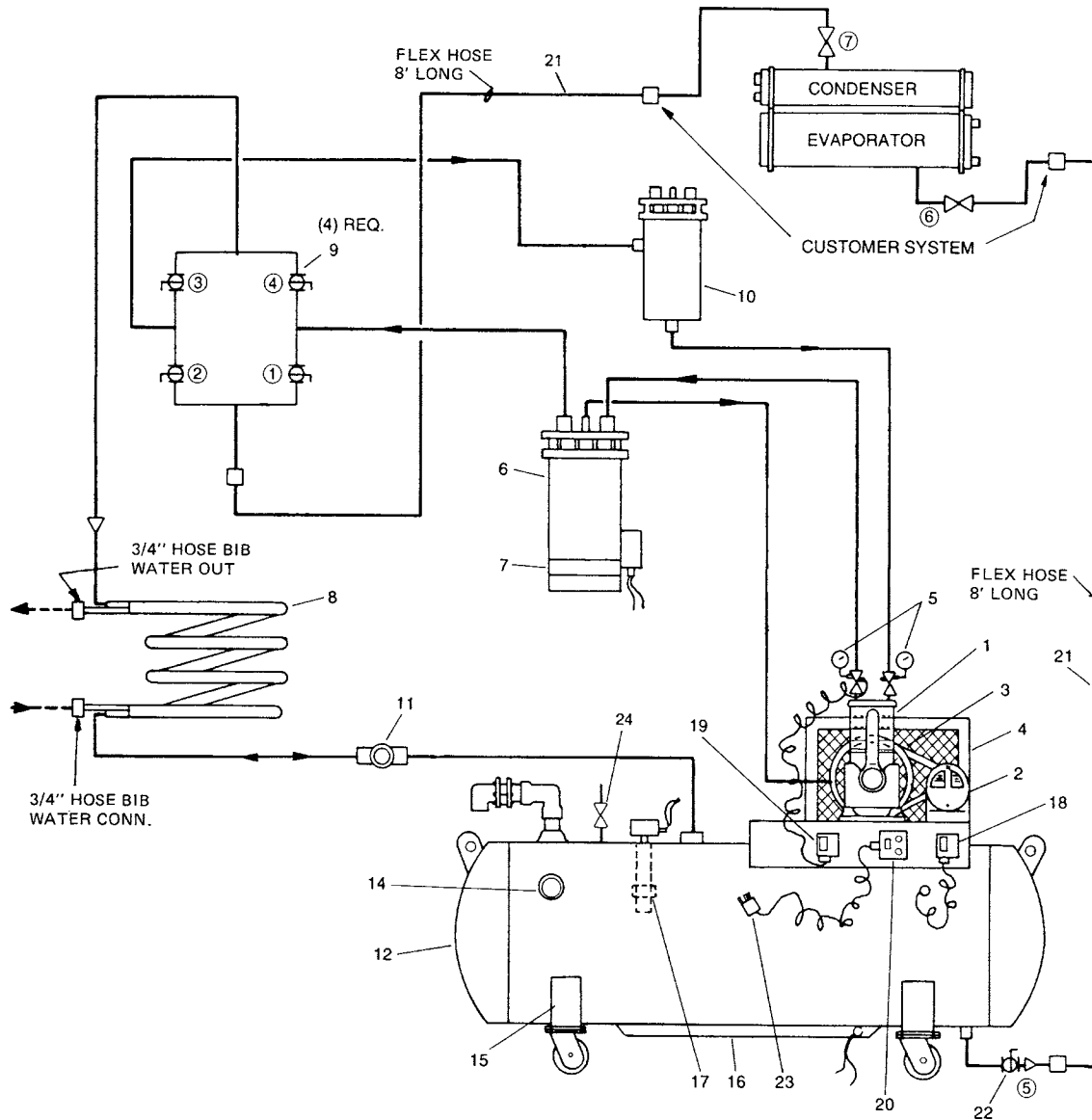

LD17567

LEGEND					
ITEM	DESCRIPTION	ITEM	DESCRIPTION	ITEM	DESCRIPTION
1	Vacuum Pump	8	Condenser	18	HP Cutout (Tank)
2	Motor	9	Ball Valves	19	HP Cutout (Compressor)
3	Drive Package:	10	Filter Dryer::	20	Junction Box:
	Motor Pulley		(1) Core		Switch-Compressor
	Compressor Pulley	11	Moisture Indicator		Switch-Heater
	Belt	12	Low Pressure Vessel	21	Refrigerant Hoses
	Base for Unit	13	Relief Assembly	22	Valve
4	Belt Guard	14	Sight Glass	23	Power Wire
5	Gauges	15	Casters	24	Purge Valve
6	Oil Separation	16	Heater		
7	Heater	17	Float Switch		

FIGURE 6 - PIPING DIAGRAM RSR-1100V, -1600V, -1100V & -1600V114

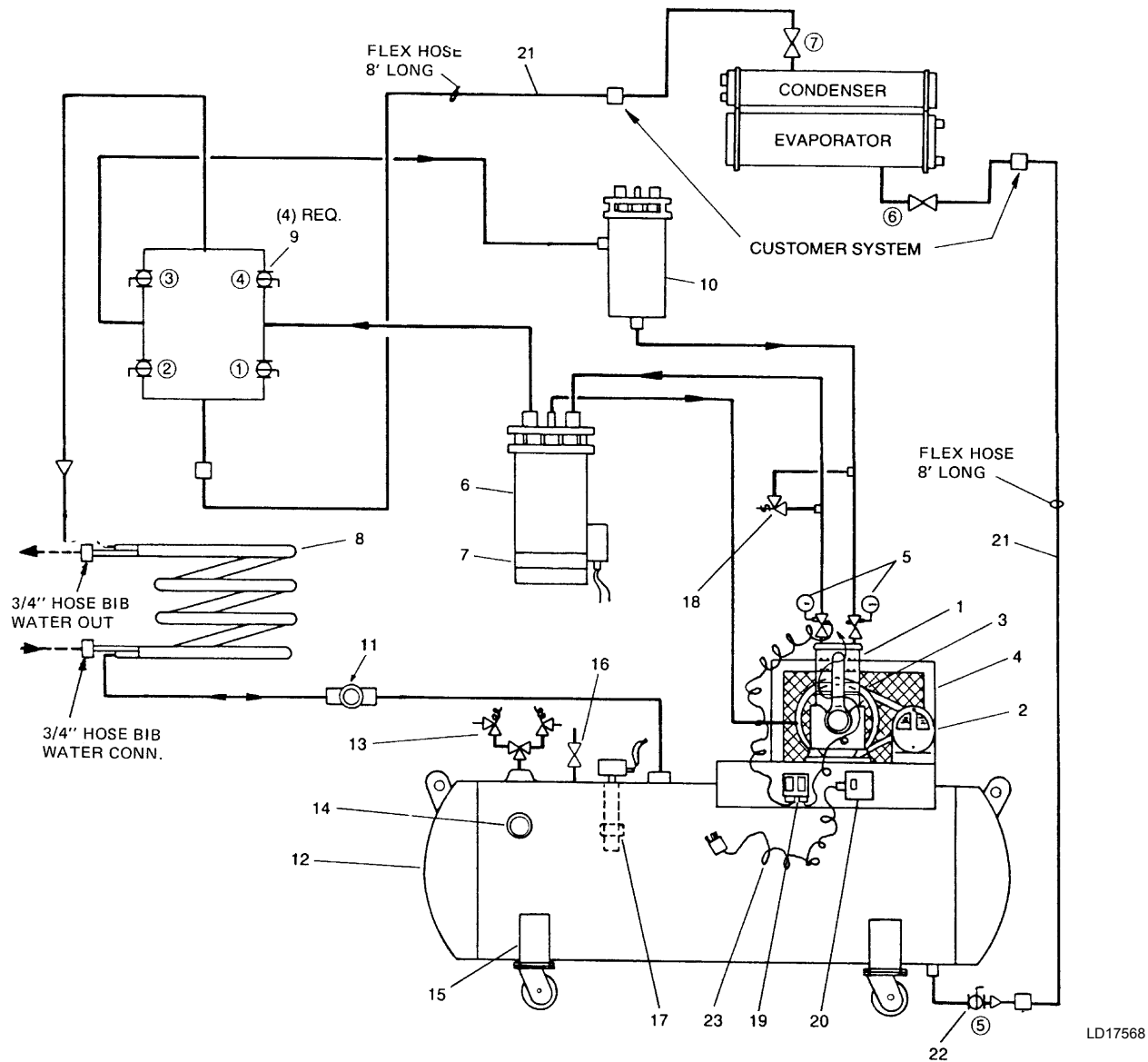

LD17568

LEGEND					
ITEM	DESCRIPTION	ITEM	DESCRIPTION	ITEM	DESCRIPTION
1	Compressor	8	Condenser	18	Relief Valve
2	Motor	9	Ball Valves	19	Pressure Switch
3	Drive Package:	10	Filter Dryer: (1) Core	20	Junction Box:
	Motor Pulley				Switch-Compressor
	Compressor Pulley	Switch-Heater			
	Belt				
	Base for Unit	11	Moisture Indicator	21	Refrigerant Hoses
4	Belt Guard	12	High Pressure Vessel	22	Valve
5	Gauges	13	Relief Assembly	23	Power Wire
6	Oil Separation	14	Sight Glass		
7	Heater	15	Casters		
		16	Purge Valve		
		17	Float Switch		

FIGURE 7 - PIPING DIAGRAM RSR-2212, -2222, -2240, -4436, -4445

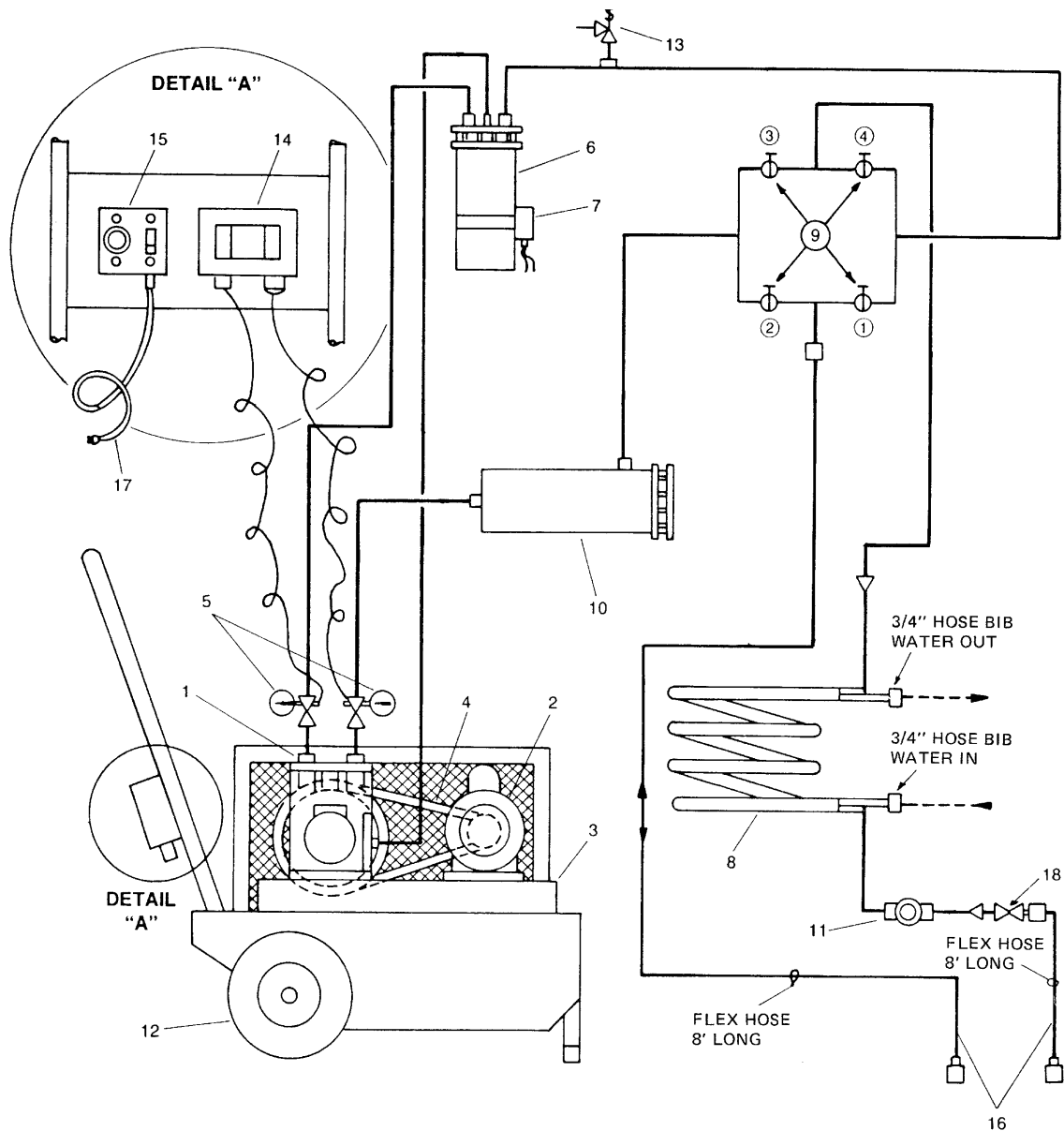

LD17569

LEGEND					
ITEM	DESCRIPTION	ITEM	DESCRIPTION	ITEM	DESCRIPTION
1	Vacuum Pump	9	Ball Valves	17	Power Wire
2	Motor	10	Filter Dryer	18	Customer Service Valve
3	Drive Package:	11	Moisture Indicator		
	Belt Guard:	12	Wheels		
4	Pulleys: Compressor	13	Relief Valve		
	Pulleys: Motor	14	Pressure Control:		
5	Gauges		Junction Box		
6	Oil Separator	15	Switches		
7	Heater Oil Separator		Remote Pressure Interlock		
8	Condenser	16	Refrigerant Hoses		

FIGURE 8 - PIPING DIAGRAM EASY-PAK RP-1000V, -114V, -2200, -2400 & -3400

THIS PAGE INTENTIONALLY LEFT BLANK.

SECTION 4 - MAINTENANCE PROCEDURES

GENERAL

Replacement of Filter Dryer Element

1. Unplug the RSR power cord.
2. Close valves 1, 2, 3 and 4 in the manifold (See *Figure 1 on page 15*) and the compressor discharge valve.
3. Remember that the system is under pressure and safety glasses and gloves should be worn during this operation.
4. Slowly turn each of the bolts, holding the end plate on the canister, open one or two turns. Allow the reduction of pressure within the canister before completely removing the end plate.
5. Remove the old filter core from the canister and remove the "O" ring gasket from the end plate. Wipe the inside of the canister and the end plate clean with a clean cloth.
6. Replace the "O" ring gasket with a new one after wiping it with a coating of the same type of oil being used in the compressor.
7. Remove the new filter/dryer element (Sporlan # RC 4864) from the hermetically sealed wrapper. The new element must be placed in the canister immediately since it would otherwise absorb moisture from the surrounding air.
8. Replace the end plate and bolt in place using an alternate pattern for tightening the bolts.
9. Prior to opening the compressor discharge valve, crack valve number 3 of the manifold and slightly break the flare connection in the tubing where it enters the compressor discharge. Allow the air to be purged from the filter dryer and then tighten the flare fitting and open the compressor discharge valve.

Belts

The Refrigerant Recovery/Recycle Unit (RSR) compressor drive belt should be checked frequently for excessive wear and tightness. If belt is in bad condition, it should be replaced immediately. Correct belt tension prevents the motor pulley from slipping, keeping the transfer unit operating at peak efficiency.

The belt tension adjustment should be made so the belt is taut, but not too taut to create excessive bearing loads. Due to the pulsating load created by the compressor, the

belt tension must be greater than for a normal steady load. Belt tension can be accurately determined with the use of a belt tension gauge which gives a direct reading of belt load as determined by the deflection. A tension of 100 lbs. is considered to be the normal belt tension.

After 36 to 48 hours of operating time, the belt should stretch to a normal operating point and a further check for proper tension should be made. Good alignment and belt tension are important to insure long belt life, quiet operation and to maintain top system performance.

Pulley Alignment

A very important factor in compressor operation is correct pulley alignment. The compressor pulley must be in perfect alignment with the motor pulley and it is important that the shaft key is in place on the shaft and the pulley bolt drawn tight, when installing a pulley. The pulley alignment may be checked by holding a 1/2" rod -2 or 3 feet long - firmly in the V groove of the compressor drive pulley wheel and making sure the rod falls squarely in the motor pulley grooves. A further check may be made by seeing that the belt, as it goes from pulley to pulley, comes off the pulley grooves perfectly straight and that there are no side-way bends in the belt, as it approaches or leaves the pulleys. Pulleys and belts must be clean and free of oil.

Adding or Changing Oil (High Pressure Units)

When the RSR is not running and the refrigerant pressures have equalized, the oil should be 1/2 to 3/4 of the height of the sight glass in the compressor oil sump.

To add oil:

1. Unplug the power cord.
2. Close the compressor discharge and suction valves and manifold valves 1 and 4 (See *Figure 1 on page 15*) and vent the pressure from the compressor. Using an oil pump, open the drain valve on the compressor sump, and pump oil into the compressor until it is at the proper level.
3. The type of oil should be the same as that used in the refrigeration unit being serviced.

To change oil:

1. Follow steps one and two above.
2. After the refrigerant pressure has been relieved to atmospheric pressure, the oil is drained from the compressor oil sump through the sump drain valve. When the oil has drained, immediately close the valve so that moisture and air do not enter the compressor.
3. To remove the oil from the oil separator, the flanged top must be unbolted and removed. First, however, the flared refrigerant tube connections must be removed from the top of the oil separator. Be sure to only slightly open the flare fittings initially to make certain the refrigerant pressure has first been relieved. Open the valve at the bottom of the separator and drain the oil.
4. Clean the interior with a clean cloth and remove and clean the screen filter.
5. After replacing the screen filter, replace the top of the oil separator.
6. Before replacing the refrigerant and oil return tubes, use a pump to pump ten fluid ounces of oil into the separator.
7. Connect the oil pump to the compressor oil drain valve – open the valve – pump ten fluid ounces of oil into the compressor sump and close the drain valve.
8. After allowing several minutes for the oil level to stabilize, check to see that the oil level is 1/2 to 3/4 above the bottom of the sight glass. If not, adjust accordingly.
9. It must be emphasized that the oil used in the high pressure RSR compressor is the same as that used in the refrigeration unit being serviced. Normally YORK Type C Refrigeration oil is used except in units charged with R-134a. An Ester base oil must be used with this refrigerant.
10. Open the compressor suction and discharge valves. And next, crack the flare fitting on the tube that connects the valve manifold to the oil separator to purge air from the compressor and oil separator.
11. Open the manifold valves as required for the next recovery operation.

Adding or Changing Oil (Low Pressure Unit)

The procedure for the vacuum pump is essentially the same as that for the compressor – the main exception being the use of DuoSeal vacuum pump oil in the pump oil sump and in the oil separator.

It is recommended that the vacuum pump be flushed with clean DuoSeal oil after draining the contaminated oil.

Flushing the Vacuum Pump

After removing all the oil, close the drain and pour about four ounces of clean DuoSeal oil into the oil fill port (see exploded view drawing for your model CAPTURE PUMP). Open the discharge port and operate the pump for about a minute with the suction port alternately opened and closed to agitate and circulate the fresh oil. Again stop the pump, drain the flushing oil and force out the residue as before. The amount of flushing oil and the number of flushes will be determined by the extent of contamination and the color of the oil. Under no circumstances should anything other than DuoSeal oil be used for flushing a CAPTURE pump. The higher vapor pressures of other types of oil will cause difficulty later in the attainment of a vacuum.

Refilling the Vacuum Pump

After you are satisfied that the pump has been thoroughly flushed, refill the pump by pouring new DuoSeal oil into the refill port. Fill to the half way point of the sight glass and start the pump with the suction closed. A gurgling noise is characteristic when high pressure air is drawn through the pump. It should disappear quickly as the pressure within the pump is reduced. If gurgling continues, and the oil level drops in the sight glass, add sufficient additional oil through the oil fill port until gurgling ceases and the oil level is at the half way point in the sight glass.

The oil level should be checked again when the pump reaches operating temperature. The oil separator should be cleaned, as previously noted and refilled with 10 ounces

Compressor

Prior to servicing the compressor:

1. Make sure the power is disconnected.
2. Close Suction and discharge service valves.
3. Bleed refrigerant from the compressor to relieve the air from the compressor and oil separator pressure within. Pressure should be 5 psig or less prior to opening the compressor.

Servicing Compressor

Care must be taken when servicing the compressor not to mar, nick or scratch any of the parts. All machined surfaces must be free of nicks or burrs to ensure a proper fit and seating of gaskets. When replacing parts and reassembly, the specified torque requirements shown in *Table 16 on page 35* should not be exceeded. Bolts should all be run in until bolt heads make contact. Final tightening should be in a sequence so that bolts diagonally opposite are tightened and all drawn evenly to the specified torque.

One of the most important factors in servicing compressors is cleanliness. Extreme care should be taken to keep foreign material from entering the compressor when it is open. All old gaskets should be replaced. Any old gasket material adhering to the parts should be carefully removed. Reusable parts should be cleaned in a solvent.

Checking Compressor for Performance

If the compressor appears not to perform properly, the following checks should be made:

1. Allow the suction pressure to build up to a minimum of 30 psig. Thoroughly check the compressor and all refrigerant holding components for leaks.
2. If no leaks are found, close the suction service valve and run compressor until compressor suction pressure is 0 psig.
3. Stop compressor. Observe discharge pressure and if it remains constant the discharge valves of the valve assembly are holding properly. If pressure drops more than 5 lbs. (34.5 kPa) in one minute, this indicates the discharge valves of the valve assembly are leaking and should be replaced. If in doubt as to whether the discharge valves leak,

turn the compressor over by hand. If pressure rises and falls with each revolution this will confirm the discharge valve leak.

4. If the discharge valves are holding then check suction valves of the valve assembly.
5. Back seat (open) the discharge service valve, with the service suction valve closed, run compressor until a vacuum of 25" (85 kPa) is reached. Failure of a compressor to reach 25" (85 kPa) vacuum indicates leaky suction valves. All compressors should pump a 25" (85 kPa) vacuum against normal head pressures.

COMPRESSOR MODEL CFC 1000

Servicing of Shaft Seal (See *Figure 9 on page 33*)

When servicing the shaft seal, extreme care must be taken when removing or installing the parts to prevent damage to the lapped surfaces and other seal parts. The portion of the shaft upon which the seal fits must be free of scratches, burrs and dirt, and the seal housing cavity must be clean.

Removal of Seal Assembly

1. Remove the sheave and key from the shaft.
2. Remove the seal retainer plate bolts and gently remove the seal plate.
3. Remove the seal assembly from the shaft.
4. Clean all parts to be reused.

Installation of Seal Assembly

1. Check all surfaces to make certain nicks and burrs do not exist.
2. Wash all parts of the seal assembly in clean oil of the same type being used in refrigeration unit being serviced.
3. Push the seal assembly onto the shaft. Move the seal assembly in and out on the shaft to ensure a good seal.
4. Place a very light film of oil on the matching metal faces where the "O" ring is to be placed. Place the "O" ring in the groove.
5. Place the seal retainer plate in position with the polished surface facing the compressor. Turn the bolts in evenly while rotating the shaft, making sure that the clearance between the shaft and the hole in the retainer plate is the same all around the circumference. If clearance is not the same all around, gently tap the seal retainer plate until it is so. Tighten bolts diagonally opposite to the required torque (See *Table 16 on page 35*).

Servicing Valve Plate and Head

In removing the head, extra care should be taken not to damage the sealing surfaces.

Removal of Head and Valve (See *Figure 9 on page 33*)

1. Remove the four bolts (15) from cylinder head.

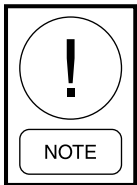

The four bolts removed are longer in length than the remaining head bolts.

2. Remove the remaining bolts in the cylinder head and remove the valve plate (3), and cylinder head from the crankcase by tapping lightly under the ears which extend from the valve plate. If the head and valve plate adhere, hold the head and tap the valve plate ears away from the head with a soft hammer. Do not hit or tap the head to separate the head and valve plate because damage to the head may result.
3. All gasket material adhering to the head, valve plate, or cylinder, should be carefully removed in such a manner that the machined sealing surfaces are not scratched or nicked.

Installation of Head and Valve Plate

1. Apply a thin film of clean YORK Refrigeration oil on the area of the crankcase to be covered by the cylinder gasket. Place the cylinder gasket in position on the cylinder so the dowel pins in the crankcase go through the dowel pin holes in the cylinder gasket.
2. Apply a thin film of clean YORK Refrigeration oil to the top and bottom valve plate area to be covered by gaskets. Place the valve plate in position on the cylinder gasket so the discharge valve assemblies (i.e. the smaller diameter assemblies with the retainer over the valve reed) are facing up and the locating dowel pins go through the dowel pin holes in the valve plate.
3. Place the head gasket (4) in position on the valve plate (3) so the dowel pins go through the dowel pin holes in the gasket.
4. Apply a light film of clean YORK Refrigeration oil on the machined surface of the cylinder head which matches the head gasket. Place the head on the cylinder head gasket so the dowel pins go into the dowel pin holes in the head.
5. Apply a thin film of clean YORK Refrigeration oil to the service valve flanges on the head and on the service valve flange. Place a service valve gasket in position on the cylinder head service valve flanges. Place the service valve in position on the proper service valve ports and insert the longer bolts through the service valve mounting pads, the head, end valve plate and in the crankcase.
6. Insert the remaining head bolts and run in all the bolts so the bolt heads make contact. Tighten the head and service valve bolts to the required torque, by tightening the service bolts first. Then tighten the remaining in a sequence so bolts diagonally opposite each other are evenly drawn to the specified torque.

SECTION 5 - REPLACEMENT PARTS AND KITS

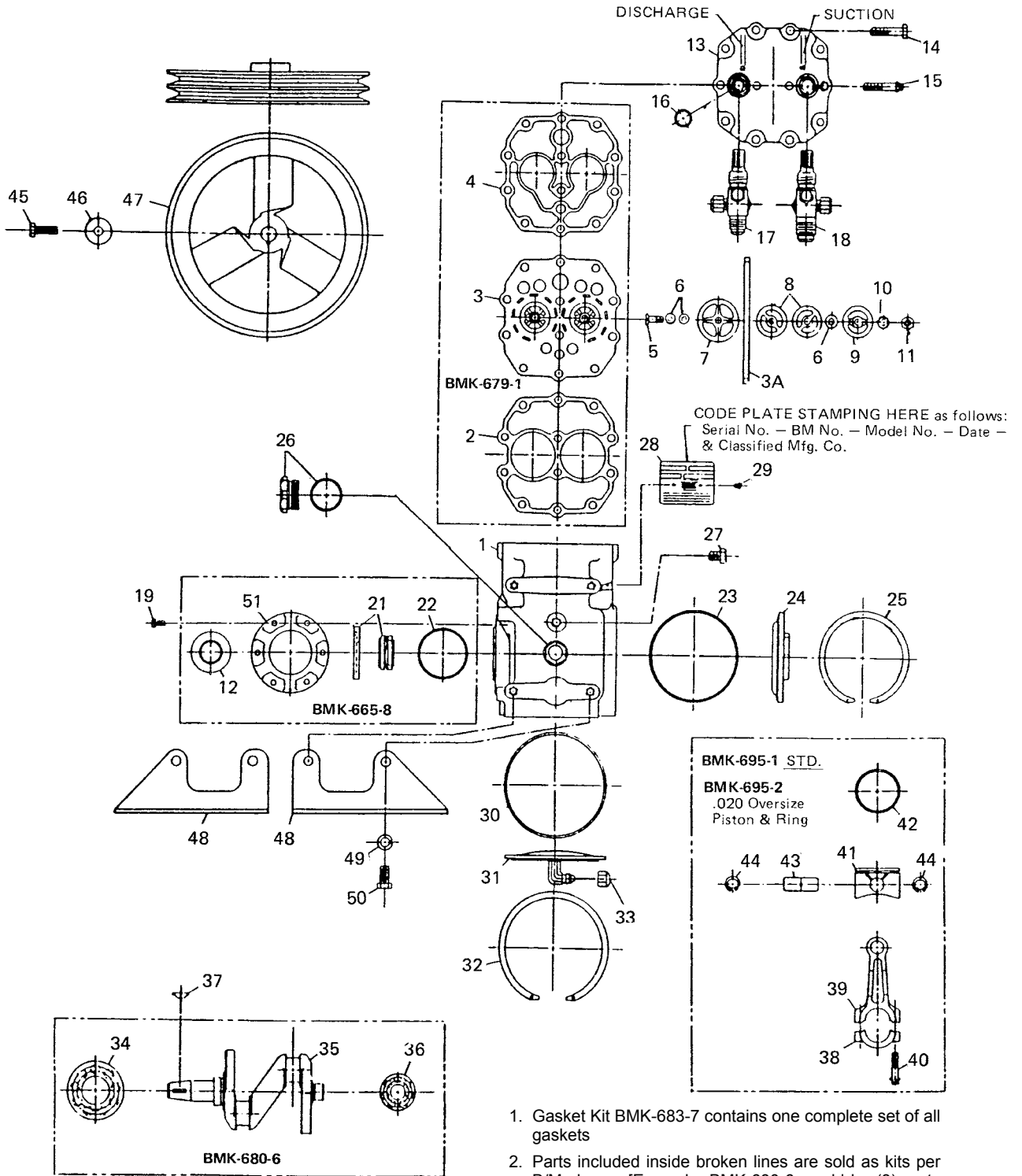

5

FIGURE 9 - COMPRESSOR REPLACEMENT PARTS - MODEL CFC-1000

LD17582

TABLE 15 - COMPRESSOR REPLACEMENT PARTS – MODEL CFC-1000

REFERENCE NUMBER	PART NAME	QTY./COMP.	PART NUMBER	REFERENCE KIT BMK
1	Crankcase	1	20031-17	679-1/683-7
2	Gasket, Valve Assembly	1	30523	679-1
3	Valve Plate Assembly	1	VP211	679 1
3a	Valve Plate	1	23019	679-1
4	Gasket, Cylinder Head	1	30563	679-1/683-7
5	Bolt	2	33188	679-1
6	Washer	6	41255	679-1
7	Suction Leaf	2	25083	679-1
8	Discharge Leaf	4	25076	679 1
9	Retainer	2	28036	679-1
10	Washer	2	12123	679-1
11	Nut	2	11040	679-1
12	Dust Shield	1	40733	665-8
13	Cylinder Head	1	24025-3	
14	Bolt, Cylinder Head	8	10004-11	
15	Bolt, Cylinder Head (Valve)	4	10049-11	
16	Gasket, Rotolock Service Valves	2	30234	683-7
18	Valve, Suction/Discharge 5/8" SAE	2	31071	
19	Screw, Seal Plate	6	10112-7	
21	Seal Assembly	1	CBS-2938	665-8
22	"O" Ring	1	5045R	665-8/683-7
23	"O" Ring	1	30525	683-7
24	Plate, Rear Bearing Housing	1	41268-1	
25	Snap Ring, Rear Bearing Housing	1	27022	
26	Oil Sight Glass With "O" Ring	1	CBL-724	
27	Plug, Oil Filter	2	5046R	
28	Serial Plate	1	52575	
29	Drive Screw, Serial Plate	2	3895	
30	"O" Ring, Bottom Plate	1	30521	683-7
31	Bottom Plate	1	245-46-3	
32	Snap Ring, Bottom Plate	1	27023	
33	Flare Cap	1	3003	
34	Ball Bearing, Front	1	26571	680-6
35	Crankshaft	1	22540-1	680-6
36	Ball Bearing, Rear	1	26553	680-6
37	Key, #6 Woodruff	1	13010	
38-40	Connecting Rod Assembly	2	AI-802	695-1
41	Piston	2	20525-1	695-1
42	Piston Ring	4	35405	695-1
43	Piston Pin	2	21520	695-1
44	Snap Ring, Piston Pin	4	27016	695-1
45	Bolt, Flywheel	1	10004-8	
46	Washer, Flywheel	1	12011	
47	Flywheel	1	25558-1	
48	Mounting Foot (Suction Side)	1	57590	
48	Mounting Foot (Discharge Side)	1	57590-1	
49	Lock Washer	4	12116-C	
50	Bolt	4	10014-C6	
51	Seal Retainer	1	41324	665-8

TABLE 16 - COMPRESSOR TORQUE SPECIFICATIONS – MODEL CFC-1000

DESCRIPTION	CAPSCREWS AND BOLTS		
	THREAD SIZE	TORQUE	
		STD. (FT. LBS)	METRIC (KM)
Rod Cap Screw	1/4-20	7-8	0.96–1.1
Valve Plate Screw	1/4-28	6	0.82
Oil Filler Plug	1/8 NPT	10–15	1.38–2.0
Bearing Retainer	1/4-28	6–7	0.82–0.96
Seal Retainer Plate	10-32	54–78	0.62–0.89
Cylinder Head	5/16-24	24–28	3.3–3.8
Flywheel Capscrew	5/16-24	24–28	3.3–3.8
Mounting Foot	3/8-16	15–20	2.0–2.7
Rotolock Valve	—	30–40	4.1–5.5
Oil Sight Glass	1 1/8-18 UNEF	75	10.4

TABLE 17 - COMPRESSOR PISTON SELECTIVE FITS

SELECTIVE FITS	CLEARANCE	
	INCHES	MM
Piston Pin to Piston	.0002/.0003	.005/.007
Piston Pin to Rod	.0002/.0003	.005/.007
Piston to Cylinder	.0032/.0042	.081/.106
Rod to Shaft Journal	.0007/.0015	.018/.038

COMPRESSOR REPLACEMENT

If the compressor fails and it is evident that the crankshaft bearings, connecting rods or pistons have been damaged, the entire compressor should be replaced.

TWIN CYLINDER MODEL CFC1000

Compressor Rotation: Either Clockwise or Counterclockwise.

Listed on *Table 15 on page 34* are the part numbers and part names for each component in our belt-driven compressor Model CFC 1000. These part numbers and part names are indexed by reference numbers as shown in *Figure 9 on page 33* which shows the layout of each part.

Please note that BMK-(number) refers to a replacement kit of parts as follows:

- BMK683-7 Gasket Kit
- BMK679-1 Valve Plate Kit
- BMK665-8 Seal Kit

- BMK680-6 Crankshaft and Bearing Kit
- BMK695-1 Piston and Rod Kit (Standard)
- BMK695-2 Piston and Rod Kit (.020 Oversize)
- BMK679-3 Valve Plate Kit (Cad & Nickel Plated)

Components in the valve plate kit, seal kit, piston and rod kit and the crankshaft kit are shown within an area enclosed by a line on the drawing on *Figure 9 on page 33*.

COMPRESSOR MODEL 16799 (RST-2240, RSR-2250 & RP-2400)

5

Shaft Seal Assembly Servicing

When servicing the shaft seal, extreme care must be taken when removing or installing the parts to prevent damage to the lapped surfaces and other seal parts. The portion of the shaft upon which the seal fits must be free of scratches, burrs and dirt, and the seal housing cavity must be clean.

Removal Of Seal Assembly (See *Figure 10 on page 37* and *Figure 11 on page 40*)

1. Remove the sheave and key from the shaft.
2. Remove the seal retainer plate bolts and gently remove the seal plate.
3. Remove the seal assembly from the shaft.
4. Clean all parts to be reused.

Installation Of Seal Assembly

1. Check all surfaces to make certain nicks and burrs do not exist.
2. Wash all parts of the seal assembly in clean YORK Refrigeration Oil.
3. Oil shaft with refrigeration oil to allow new seal to be pushed into position.
4. Put on spring holder and spring. Be sure that spring is centered in spring holder.
5. Slide the assembly along shaft just far enough to center in spring and hold spring in place. Do not compress the spring at this stage.
6. Before putting on end plate, thoroughly clean and oil with 300 viscosity refrigeration oil on both sealing faces. Install floating seats in end plate as follows:

7. Make sure that the synthetic rubber seat ring is tight against the shoulder of the floating seat, with rounded outer edge at the rear to facilitate insertion. The ring is assembled this way when shipped. See that there is a 1/32" (0.79 mm) minimum radius (do not chamfer) on the edge of the cavity which holds the floating seat and seat ring. Oil the outer surface of the seat ring with refrigeration oil, and push the assembly into the cavity seating it firmly and squarely.
8. Slide end plate on shaft and press it in as far as it will go. Do not allow it to spring out or move backward. Tighten screws or bolts uniformly to keep the face of the seat at right angles to shaft. Tightening of end plate automatically sets seal in proper position. Be sure to use the torque requirement specified for the seal assembly. (See *Table 18 on page 36*)

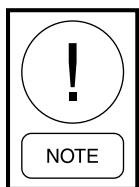

After seal installation is completed, rotate the compressor by hand several times to help seat the seal mating surface.

TABLE 18 - TORQUE VALUES FOR MODEL 16799 COMPRESSOR

DESCRIPTION	TORQUE	
	FT. LBS.	KM
Head	25 – 30	3.4 – 4.1
Clamping Stud	32 – 35	4.4 – 4.8
Cylinder to Crankcase	25 – 30	3.4 – 4.1
Shaft End Plate	9 – 15	1.2 – 2.1
Seal End Plate	9 – 15	1.2 – 2.1

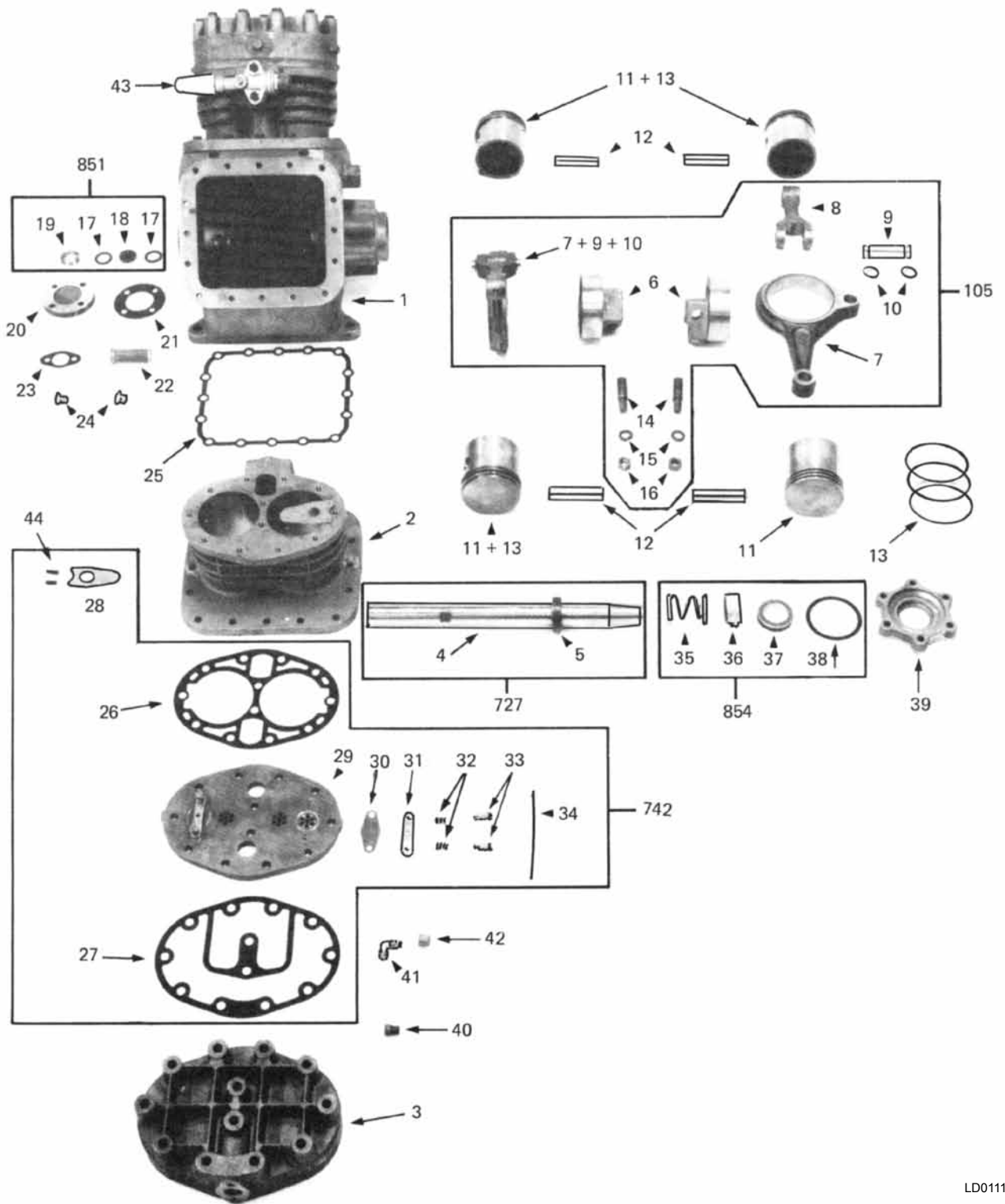

5

FIGURE 10 - COMPRESSOR REPLACEMENT PARTS – DISCONTINUED MODEL 16799

LD01115

TABLE 19 - COMPRESSOR REPLACEMENT PARTS – DISCONTINUED MODEL 16799

REFERENCE NUMBER	PART NAME	NUMBER REQUIRED	PART NUMBER
	Model 16799 compressor assy. 4 cylinder,3-1/4" bore x 2-1/4" stroke		16799
1	Crankcase (includes front & rear bushing)	1	16800
2	Cylinder	2	16801
3	Cylinder Head	2	16702
4	Crankshaft	1	16703*
5	Crankshaft Collar	1	16704*
727	Crankshaft Assembly	1	16705
6	Eccentric	2	16706*
7	Connecting Rod	2	16802*
8	Connecting Rod Link	2	16803*
9	Link Pin	2	16804*
10	Link Pin Retaining Ring	4	16805*
105	Eccentric and Connecting Rod Assy.	1	16806
11	Piston	4	16710
12	Wrist Pin Assembly	4	16709
13	Piston Ring	12	16711
14	Clamping Stud	2	16731
15	Lock Washer 1/2" heavy	2	30013
16	Hex Nut 1/220NF-2	2	30012
17	Sight Glass Gasket	2	16807
18	Sight Glass	1	16811*
19	Sight Glass Retaining Ring	1	16809*
851	Sight Glass Assembly	1	16808
20	Shaft End Plate	1	16727
21	Shaft End Plate Gasket	1	16726
22	Suction Screen	2	16725
23	Service Valve Gasket	5	16728
24	Oil Fill and Drain Plug	2	16729
25	Crankcase Gasket (Model No. 16799 and D-799)	2	16724
26	Cylinder Gasket	2	16723
27	Head Gasket	2	16722
28	Suction Reed	4	16718
29	Valve Plate	2	16712*
30	Discharge Reed	4	16713*
31	Discharge Valve Reed Retainer	4	16714*
32	Discharge Valve Spring	8	16715*
33	Discharge Valve Screw	8	16716*
34	Discharge Valve Lock Wire	4	19 Ga.*
742	Valve Plate Assembly (includes repair gaskets)	2	16717
35	Shaft Seal Spring	1	*
36	Shaft Seal Ring	1	*
37	Shaft Seal Carbon	1	*
854	Shaft Seal Assembly (includes repair gasket)	1	16999

TABLE 19 - COMPRESSOR REPLACEMENT PARTS – DISCONTINUED MODEL 16799 (CONT'D)

REFERENCE NUMBER	PART NAME	NUMBER REQUIRED	PART NUMBER
38	Seal End Plate Gasket	1	16720
39	Seal End Plate	1	16721
40	Head Pipe Plug 1/8"	3	16036
41	Half Union Elbow	1	16037
42	Flare Cap 1/4"	1	16730
43	Service Valve, Compressor Suction 7/8S.	2	16737
	Service Valve, Compressor Discharge 7/8S.	1	16737
44	Dowel Pins	8	16034
	Front Bushing - Crankcase	1	16733**
	Rear Bushing - Crankcase	1	16734**
	Complete Gasket Set	1	16816
	Discharge Manifold Crossover Tube Assembly	1	16815

* Part cannot be ordered separately. Must be ordered as complete Assembly.

** Must be line bored and reamed after pressing into crankcase.

All parts used in Model D799 same as Model 16799 except for the following:

TABLE 20 - MODEL D799 COMPRESSOR PARTS (OLD STYLE)

DETAIL NUMBER	PART NAME	NUMBER REQUIRED	PART NO.
1	Crankcase (includes front & rear bushing)	1	16900
2	Cylinder	2	16902

Changing the Valve Plate Assembly (See *Figure 10 on page 37 and Figure 11 on page 40*)

1. Remove cylinder head bolts, cylinder head and valve plate assembly from compressor.
2. Remove all traces of gasket material from both the cylinder and the cylinder head flanges.
3. Thoroughly clean the cylinder head using a good solvent as a cleaning agent.
4. Thoroughly clean the top of the pistons and the cylinder flange: The most efficient manner in which to accomplish this is to bring one piston flush with the top of the cylinder and clean the top of the piston and approximately one-half of the cylinder flange in one operation. This process should be repeated for each cylinder using a good solvent as a cleaning agent.

5. Place the valve plate gasket on the cylinder head following the outline of the cylinder head itself to insure correct gasket position. Use a thin film of refrigerant oil to make gasket adhere to cylinder head.
6. Place the cylinder gasket on the cylinder flange using a thin film of refrigerant oil to make gasket adhere to the cylinder flange.
7. Thoroughly clean the valve plate assembly with a good solvent.
8. Place suction reeds on the cylinder dowel pins.
9. Place the valve plate assembly on the cylinder using the cylinder dowel pins as a guide.
10. Replace the cylinder head (on which the valve plate gasket has already been placed—See No. 4 above) and make certain the discharge outlet is opposite the suction port on the cylinder.
11. Replace cylinder head and tighten belts, using the torque requirement specified for the valve plate (See *Table 18 on page 36*).

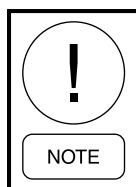

Do not allow any solvent to seep into crankcase oil.

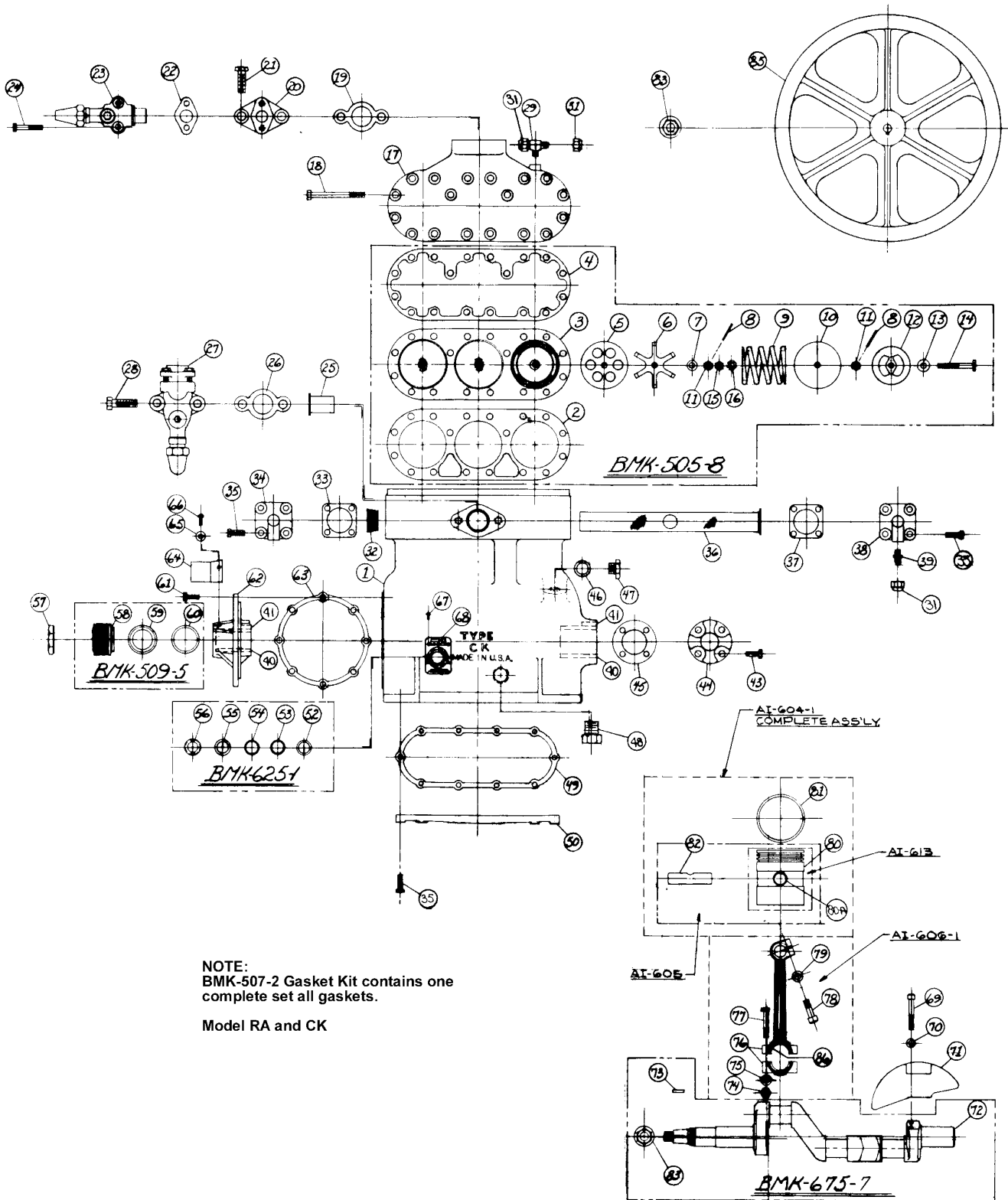

LD03861

FIGURE 11 - COMPRESSOR REPLACEMENT PARTS – MODELS RA AND CK

TABLE 21 - COMPRESSOR THREE CYLINDER MODEL RA & CK – BM-99301, -99302 & -99303

REFERENCE NUMBER	PART NUMBER	QUANTITY/ COMPRESSOR	PART NUMBER	REFERENCE KIT BMK-
1	Crankcase & Bearing Assembly	1	20012-1	
2	Gasket (Valve Plate)	1	30078	505-8, 507-2
3	Valve Plate Assembly	1	VP184	505-8
4	Gasket (Cylinder Head)	1	30079	505-8, 507-2
5	Discharge Leaf	3	25046	505-8
6	Discharge Leaf Retainer	3	28025	505-8
7	Spacer Washer	3	12032	505-8
8	Lock Wire	6	41097	505-8
9	Discharge Valve Spring	3	26205	505-8
10	Retainer	3	28026	505-8
11	Discharge Valve Nut	6	11213	505-8
12	Suction Leaf	3	25045	505-8
13	Suction Valve Washer	3	12031	505-8
14	Valve Screw	3	33160	505-8
15	Discharge Valve Nut	3	11212	505-8
16	Lockwasher	3	12307	505-8
17	Cylinder Head	1	24016	
18	Capscrew (Cylinder Head)	18	33162	
19	Gasket (Adapter Plate)	1	30047	507-2
20	Adapter Plate	1	41176	
21	Capscrew	2	10020-12	
22	Gasket (Discharge S.O.V.)	1	30048	507-2
23	Discharge S.O.V.	1	31012-1	
24	Screw	2	10012-6	
25	Connector Tube	1	34150	
26	Gasket (Suction S.O.V.)	1	30047	507-2
27	Suction S.O.V.	1	31030	
28	Capscrew	2	10020-14	
29	Tee	1	60007	
31	Flare Cap	3	3003	
32	Suction Strainer Spring	1	26206	
33	Gasket (Suction Cover Plate)	1	30016	507-2
34	Suction Cover Plate	1	41110-2	
35	Capscrew	18	10010-8	
36	Suction Strainer Assembly	1	27508	
37	Gasket (Suction Cover Plate)	1	30016	507-2
38	Suction Cover Plate	1	41110-1	
39	Union	1	60213	
40	Main Bearing	2	41099-P1	
41	Dowel Pin	2	41074	
43	Capscrew	4	10010-7	
44	End Plate	1	41152	
45	Gasket (End Plate)	1	30063	507-2

5

TABLE 21 - COMPRESSOR THREE CYLINDER MODEL RA & CK – BM-99301, -99302 & -99303 (CONT'D)

REFERENCE NUMBER	PART NUMBER	QUANTITY/ COMPRESSOR	PART NUMBER	REFERENCE KIT: BMK-
46	Gasket (Oil Filler Plug)	1	30011	507-2
47	Oil Filler Plug	1	40176	
48	Crankcase Plug (Heater)	1	CBW2682	
49	Gasket (Bottom Plate)	1	30065	507-2
50	Bottom Plate	1	24531	
52	Gasket (Sight Glass)	1	30012	625-1, 507-2
53	Sight Glass	1	40180	625-1
54	Gasket (Sight Glass)	1	30013	625-1, 507-2
55	Thrust Washer (Sight Glass)	1	40181	625-1
56	Retainer Nut (Sight Glass)	1	40182	625-1
57	Seal Nut	1	11031	
58	Seal Bellows Assembly	1	41151	509-4, 509-5
59	Seal Seat	1	41018	509-4, 509-5
60	Seal Ring	1	41014	509-4, 509-5
61	Capscrew	8	10010-7	
62	Housing Cover & Bearing Assembly	1	41099-1	509-4
63	Gasket (Housing Cover)	1	30060	507-2, 509-4
64	Seal Guard	1	41145	
65	Lock Washer	2	12109	
66	Machine Screw	2	10106-C6	
67	Drive Screw	2	10403C	
68	Serial Plate	1	CBW2641	
69	Screw	4	33251	
70	Lockwasher	4	2177	
71	Counterweight	2	23520-1	
72	Crankshaft	1	22518-5	675-7
73	Key	1	CBW2625	675-7
74	Nut	6	11030	AI606-1
75	Lock Washer	6	2174	AI606-1
76	Connecting Rod	3	AI606-1	
77	Rod Bolt	6	33161	AI606-1
78	Lockscrew	3	10030-10	AI606-1
79	Lock Washer	3	2174	AI606-1
80	Piston & Bushing Assembly	3	AI613	AI605
80A*	Piston Bushing	6	41149	AI605
81	Piston Ring	9	41150-1	
82	Piston Pin	3	21509	AI605
83	Flywheel Locknut	1	CBW2708	675-7
85	Flywheel	1	25531-2	
86	Rod Bearing Inserts	6	CBW2508	A1606-1 AI604-1

Note: Only parts that can be ordered over-sized are 41150-2 .030, AI605 .030, AI613 .030 and CBW2508 .010.

VACUUM PUMP – MODEL CRR-1

Gurgling Noise

The vacuum pump will gurgle to varying degrees under three different conditions of performance:

1. When operating at high pressure as in the beginning of the evacuation cycle.
2. When the oil level in the pump is low.
3. When a large leak is present in the system being evacuated.

Suction and Discharge Pressure Problems

Leakage, oil contamination, V-belt slippage and low oil level are four major causes of insufficient suction or discharge pressure. If the recovery and/or recycle system is free from leaks, and unwarranted suction problems still exist, the pump should be checked. A simple criterion for the condition of the vacuum pump is a determination of its ultimate pressure capability. If the suction obtainable is very poor, the pump may be badly contaminated, low on oil or malfunctioning. On the other hand, if the pressure is only slightly higher than the guaranteed ultimate pressure of the pump, an oil change may be all that is required.

If the recovery and/or recycle system is free from leaks and sufficient suction exists, but the discharge pressure is insufficient, there are several sources to the problem. A simple explanation, there is an insufficient flow of refrigerant vapor into the vacuum pump. Check to see that the tubing connecting the suction port to the chiller is not obstructed. A low oil level or V-belt slippage can cause the same symptoms. If there is a leak in the oil case of the vacuum pump, this can also cause insufficient discharge pressure. If none of these explanations fit the observations, the pump may be malfunctioning and should be sent back to a repair facility.

SHAFT SEAL REPLACEMENT

To replace the shaft seal of a pump, drain the oil and remove the pump pulley and key. Remove the screws securing the old seal and pry it loose with a screwdriver or similar wedge, being careful not to mar the surface of the pump body against which the seal fits. Discard the seal and its gasket, inspect all surfaces and repair any damages with a fine abrasive stone. Wipe all sealing areas clean and place a film of DuoSeal oil on both the shaft and the inside bore of the new shaft seal. Using a new gasket, carefully slide the new seal into position and center it on the shaft. It is not necessary to apply any sealant to the gasket. Tighten the mounting screws uniformly and refill the pump with DuoSeal oil. Follow instructions included in repair kit.

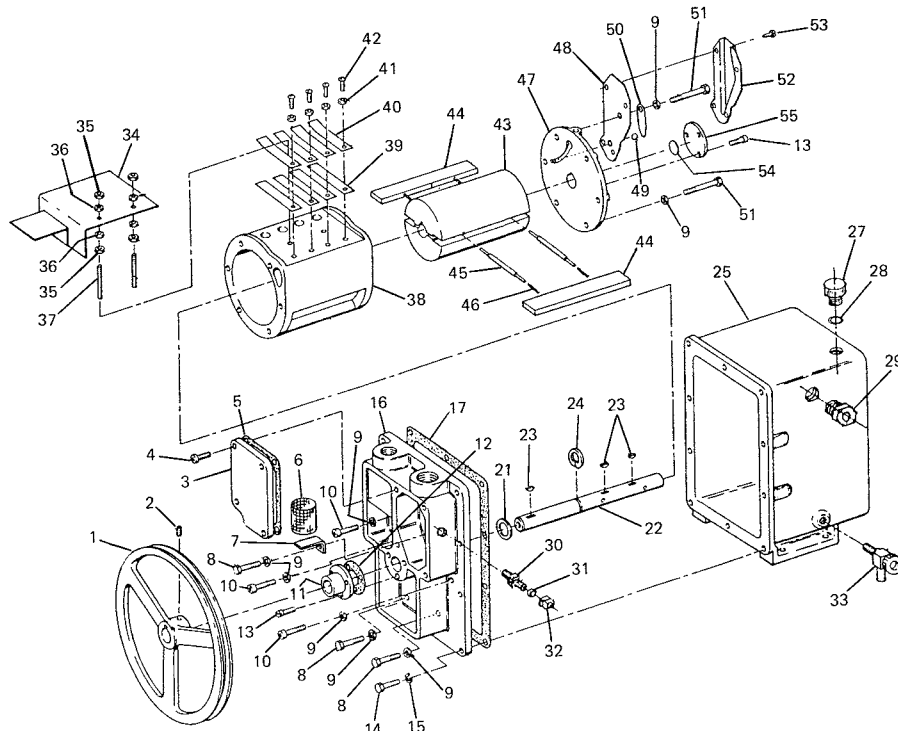

FIGURE 12 - VACUUM PUMP REPLACEMENT PARTS – MODEL CRR-1

LD01114

TABLE 22 - VACUUM PUMP REPLACEMENT PARTS – MODEL CRR-1

REFERENCE NUMBER	PART NAME	QUANTITY	PART NUMBER
1	Pulley, Includes Setscrew, Item 2	1	41-2074
2	Socket Head Steel Setscrew 5/16 – 18 x 3/8	1	2-01-9306
3	Large End Plate Cover	1	41-0775
4	Socket Hd. Cap Screw, 1/4 – 20 x 3/4	4	2-01-6112
5	Intake Chamber Cover Gasket	1	41-0234
6	Air Filter	1	41-1692
7	Air Filter Bracket	1	41-0663
8	Hex. Hd. Cap Screw 5/16 – 18 x 1	3	2-01-0316
9	Washer, Copper 5/16 ID	6	61-8456A
10	Soc. Hd. Cap Screw 5/16 – 18 x 1	3	2-01-6316
11	Shaft Seal, Includes Items 3, 12 & 13	1	1401D
12	Seal Gasket	1	41-0643
13	Fill Hd. Screw 10 – 32 x 3/8	6	2-00-2706
14	Hex Hd. Cap Screw, 1/4 – 20 x 3/4	10	2-01-0112
15	Split Lockwasher, 3/4	10	2-63-0193
16	Large End Plate	1	61-8416D
17	Oil Case Gasket	1	41-0403
19	Washer	6	41-2363
21	Washer	1	41-0508
22	Shaft	1	41-1762
23	Woodruff Key	3	41-0624
24	Retaining Ring	1	4-06-0754
25	Oil Case Assy. (See Note 1)	1	61-8417D
27	Plug, Oil Fill	1	41-2933
28	O-Ring	1	61-8420
29	Oil Level Window (See Note 4)	2	61-8418
30	Male Connector	1	61-8421
31	Copper Seal Cap	1	61-8423
32	Short Nut	1	61-8422
33	Drain Valve	1	41-1734
34	Baffle Plate	1	41-1769
35	Hex. Nut 1/4 - 20	4	2-31-0112
36	Steel Washer, 1/4	4	2-61-3100
37	Headless Setscrew	2	41-2175
38	Ring	1	41-1760
39	Lower Exhaust Valve	4	41-1768
40	Upper Exhaust Valve	4	41-1779
41	Steel Washer	4	2-61-0000
42	Rd. Hd. Screw, 1/4 – 20 x 3/8	4	2-01-5106
43	Rotor	1	41-1761
44	Vane	2	41-1684
45	Spring Holder	2	41-1685
46	Vane Spring	4	41-1304
47	End Plate	1	41-2045

TABLE 22 - VACUUM PUMP REPLACEMENT PARTS – MODEL CRR-1 (CONT'D)

REFERENCE NUMBER	PART NAME	QUANTITY	PART NUMBER
48	Pressure Rls. Tube Number 2	1	41-1005
49	Steel Ball 3/8 Dia.	1	4-40-1200
50	Pressure Release Valve	1	41-0992
51	Hex Hd. Cap Screw, 5/16 – 18 x 1/4	6	2-01-0320
52	Pressure Rls. Tube Number 1	1	41-0986
53	Sheet Metal Screw Number 6 x 1/4	3	2-03-3104
54	Thrust Disk	1	41-1766
55	End Cap	1	41-0672

*Oil Case Assembly (61-417D) includes oil case, drain valve and level window.

REPAIRING OIL LEAKS

Location, Cause and Effect

Oil leaks may develop wherever two mating faces are sealed with a gasket. Such seams may fail as the result of deterioration of the gasket material, loosening of the screws caused by temperature variations, or improper care as the result of previous reassembly. Typical gasketed seams in a vacuum pump are located at the shaft seal and the mating faces of such mechanical surfaces as the suction chamber cover, the oil case, and the discharge chamber cover. The importance of a gasketed seam is determined principally by its function. If it is a vacuum seal, the ultimate performance of the pump is dependent upon it. If it is an oil seal, the pump may be operated satisfactorily for some time without loss of function. Eventually, of course, a great loss of oil may cause harmful damage.

Repairing Technique

Thin composition gaskets are generally used for large irregularly shaped areas. A replacement joint of this type should be thoroughly cleaned of all previous gasket material and the mating surfaces cleaned of any nicks.

REPAIRING VACUUM LEAKS

Good vacuum seals are an essential and important attribute of a vacuum pump. A good seal is dependent upon the quality of the mating surfaces as well as the sealant and its preparation. The mating faces should be carefully inspected for any projections or foreign particles which might interfere with proper mating. Slight projections such as nicks and burrs are most easily removed by rubbing with a fine abrasive stone. The surface of the mating parts may be washed with a solvent or alcohol after which they must be thoroughly dried.

DORIN		M/COMPRESSORE M/COMPRESSORS M/COMPRESSEURS MOTORKOMPRESS	51VSM
Model 51VSM		Displacement 949 cm ³ N° cylinders 2	Rotation looking from driving end Orario
Swept volume 1450 RPM 82,56 mc/h 1750 RPM 99,64 mc/h		Bore 88 Stroke 78 Oil charge 4 Kg.	Suction connection 42s Discharge connection 35s Net weight with flywheel 118 Kg
Max operating pressure BP 20 bar AP 25 bar		Sound power dBA ISO9614-1gr.2 Condit. 0 Refrig. 0	Operating speed range 600 RPM min. 1300 RPM max.
Driving motor power range 7,5-25 HP		Flywheel diameter External 335 mm Primit. 328 mm	Driving belts Nr 4 Type B
Type of lubrication A sbattimento		Type of oil with refrig. HCFC (CFC) Standard Suniso 3GS	Type of oil with refrig. HFC Opzionale POE 32
Std painting RAL5008	Gros weight 131 Kg.	Packing dimensions LxPxH 720x540x600 mm	Packing volume 0,233 m ³
A Spia Olio	Oil Sight	Voyant d'huile	Oelschauglas
B Tappo carica Olio	Oil charge plug	Bouchon huile	Oelfuellschraube
C Presa Bassa Pres.	Low pressure tap	Prise basse pression	Anschluss Niederdruck
D Presa Alta Press.	High pressure tap	Prise haute pression	Anschluss Hochdruck
DL Rubinetto Compressione	Discharge service valve	Vanne de refoulement	Druckabsperventil
SL Rubinetto Aspirazione	Suction service valve	Vanne aspiration	Saugabsperventil
E Tappo scarico olio	Oil drain plug	Bouchon de vid,d'huile	Oelablass Schraube
F Resistenza carter	Crankcase heater	Resistance carter	Oelsumpfheizung
Available accessories			
Description		Supply	
CH=Crankcase Heater		Option	
BF=Body cooling fan		Option	
WH=Water cooled head		Option	
US=By-pass system		Option	
OL=Oil level float valve		Option	
PDD=Double pressure switch		Option	
OS=Oil separator		Option	
LS=Liquid separator		Option	

LD17570

FIGURE 13 - COMPRESSOR DATA SHEET – MODEL 51VSM

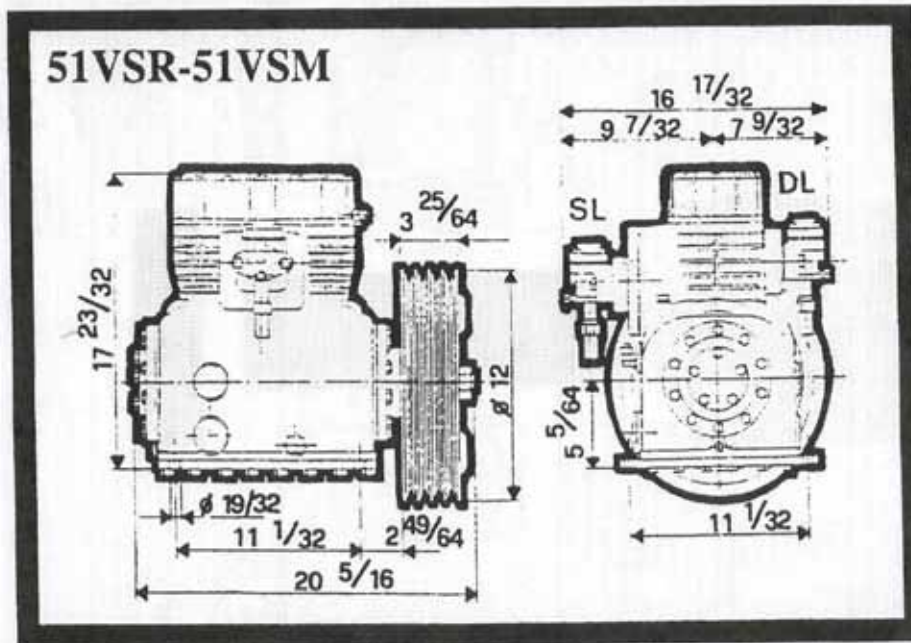

LD17571

FIGURE 14 - COMPRESSOR DIMENSIONS – ENGLISH – 51VSM

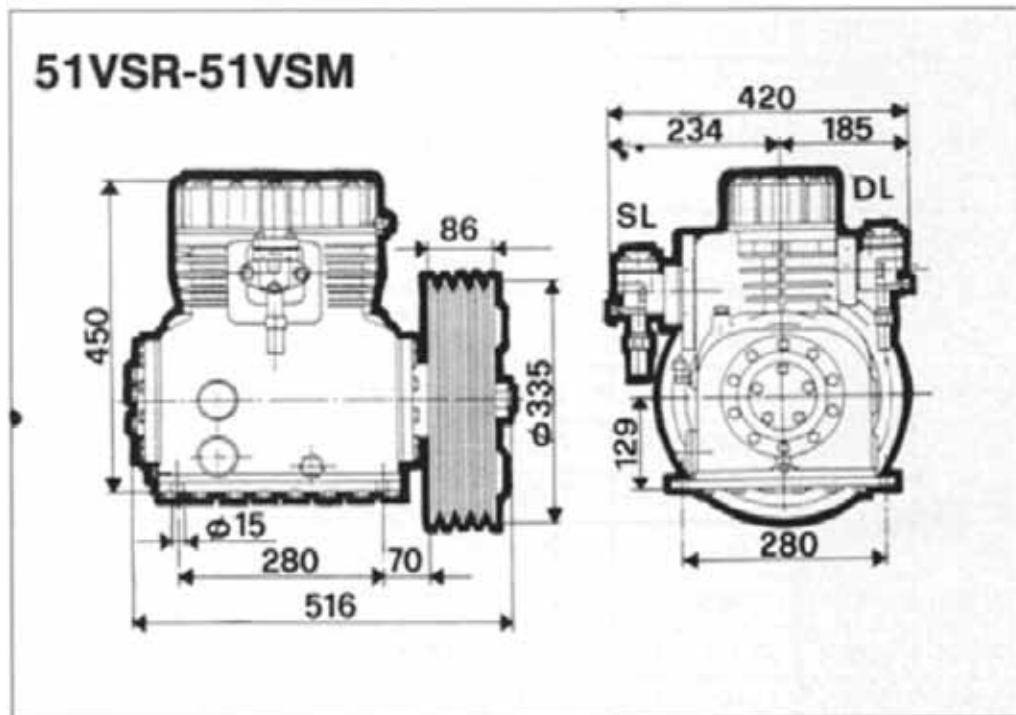

LD17576

FIGURE 15 - COMPRESSOR DIMENSIONS – METRIC – 51VSM

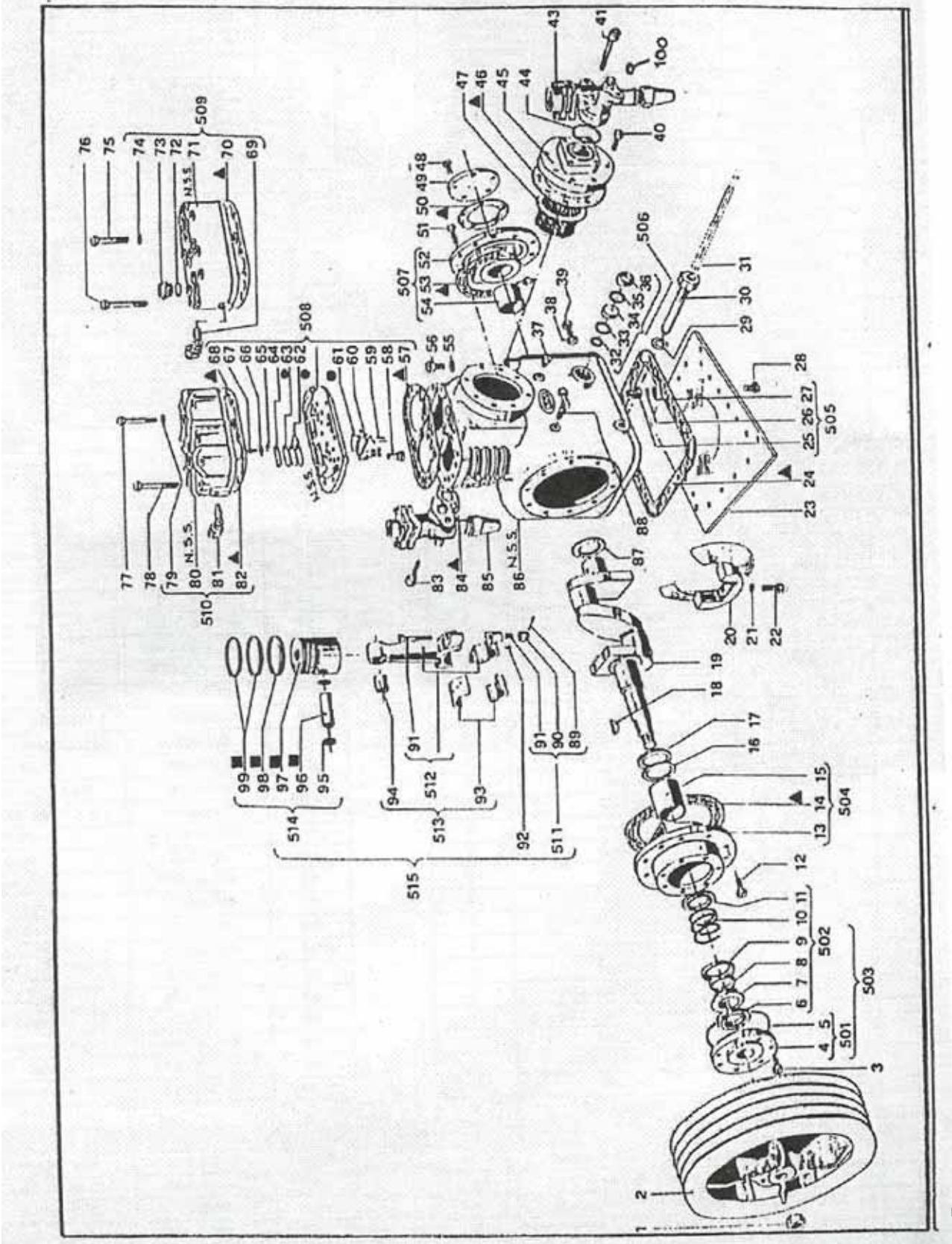

LD17572

FIGURE 16 - COMPRESSOR PARTS - 51VSM

TABLE 23 - COMPRESSOR PARTS – 51VSM

51VSM

Print #	Part Number	Description	Qty
1	1MVB051	Flywheel Nut	1
2	1MFE102	Flywheel 4B	1
3	3VEBD08025	Screw	1
4	1TFA041	Seal Assy. Fl.	1
5	1TDH101	O-Ring	1
6	2PQ2050	Ring	1
7	2PR2050	Rubber Collar	1
8	2PV2050	Cellar Ring	1
9	2PS2050	Housing	1
10	2PT2050	Spring	1
11	2PU2050	Spring Seat Di.	1
12	3VEBD10030	Screw	10
13	1CFC121	Main Hub	1
14	◆ 1CGE051	Gasket	1
15	1CBD051	Bearing	1
16	1MDN041	Washer 0.3	1
16	1MDN051	Washer 0.4	1
16	1MDN061	Washer 0.5	1
17	1MDG131	Thrust Washer	1
18	1MDC031	Key	1
19	1MFB091	Shaft	1
20	1MFF031	Crank. Count. Wel.	2
21	2DC1020	Washer	4
22	3VCBD10030	Screw	4
23	1CDP051	Crankcase Bottom	1
24	◆ 1CGF051	Gasket	1
25	1CDG021	Turnout	1
26	1CDH021	Disk Valve	1
27	3AE020	Circlip	1
28	3VEBF10030	Screw	24
29	1CGK051	Gasket	1
30	1CDJ011	Sheath	1
31	2EG1020	Resistance	1
32	1CDE021	Ring	1
33	1CDR021	Ring	1
34	1CDC021	Sight Glass	1
35	◆ 1CGC021	Gasket	1
36	1CDD021	Warning Nut Ring	1
37	2TE1010	Plug 1/4 Gas	1
38	2DC1030	Gasket	1
39	3VEBD08016	Screw	1
40	3VEBD10030	Screw	8
41	3VBM12045	Screw	2
41	3VCBL12090	Screw	4
43	2RLD763	Suc. Ser. V. 51VSM	1
43	2RSQ961	Suc. Ser. V. 51VSR	1
44	1CGH101	Gasket	1
44	1CGH131	Gasket	1
45	1CFF072	Suction Port 42s	1
45	1CFF082	Suction Port 35s	1
46	◆ 1CGD061	Gasket	1
47	1CDA081	Suction Filter	1
48	3VEBD10025	Screw	5
49	1CDF051	Thrust Plug	1

Print #	Part Number	Description	Qty
50	◆ 1CGG051	Gasket	1
51	3VEBD10030	Screw	10
52	1CFG131	Rear Hub	1
53	◆ 1CGE051	Gasket	1
54	1CBD061	Bearing	1
55	2DC1070	Gasket	1
56	3VECD12020	Screw	1
57	◆ 1PGA131	Gasket	1
58	1PDS011	Limiting Device	2
59	3R25078	Peg	12
60	1PDP071	Plate	6
61	● 1PDA122	Suction Valve	12
62	● 1PDB051	Discharge Valve	12
63	● 1PDB061	Discharge Valve	6
64	1PDH061	Compress. Bridge	6
65	3R25078	Peg	12
66	3VRBT06	Washer	6
67	1PDE041	Screw	6
68	◆ 1PGB101	Gasket	1
69	1CCE011	Turnout	1
70	◆ 1PGB101	Gasket	1
71	1CFD071	Water Head	1
72	2DD1020	Gasket	2
73	1CDQ021	Water Turnout	2
74	2DC1030	Gasket	2
75	3VEAF10110	Screw	13
76	3VEAF08090	Screw	2
77	3VEAF08080	Screw	2
78	3VEAF10100	Screw	13
79	2DC1030	Gasket	2
80	1CFC121	Air Head	1
81	1CCE011	Turnout	1
82	◆ 1PGB101	Gasket	1
83	3VCBM12045	Screw	2
84	◆ 1CGH131	Gasket	1
85	2RSQ969	Disch. Ser. V. 51VSR	1
85	2RSQ961	Disch. Ser. V. 51VSM	1
86	1CCA024	Crankcase W/ Bearing	1
86	1CFA091	Crankcase	1
87	1MDG141	Rear Thrust Was.	1
88	1CCE011	Turnout	1
89	3VFAA18015	Split Pin	4
90	1MVD031	Nut	4
91	1MVC051	Screw	4
92	1MDU021	Screw	2
93	1MBA021	Bearing	2
94	1MBA021	Bearing	2
95	3AB022	Circlip	4
96	1MDF131	Piston Pin	2
97	1MDE461	Piston Pin	2
98	1MDP051	Oil Scraper Ring	2
99	1MDQ161	Piston Ring	4
100	3VRCV12	Washer	4

Kits

501	1TCD006	Flange with Gasket	1	510	1CCS009	Air Cooled Head	1
502	1TCA016	Seal Assembly	1	511	1MVC066	Screw, Nut & Pin	4
503	1TCC015	Seal Assy w/flange & G	1	512	1MFD191	Conn. Rod w/ Bolt	2
504	1CCC008	Front Hub w/ Bearing	1	513	1MCB021	Conn. Rod w/ Bearing	2
505	1CCD002	Oil Check Valve	1	514	1MCE461	Piston, Pin & Rings	2
506	1CCQ002	Oil Sight Glass Kit	1	515	1MCD018	Piston & Rod Kit	2
507	1CCC007	Rear Hub w/Bearing	1				
508	1PCB014	Valve Plate Kit	1	◆	1CCM026	Gasket Kit	1
509	1CCT007	Water Cooled Head	1	●	1PCC008	Valve Leaf Set	1

5

BLISSFIELD/DORIN MODEL 51VSM BELT DRIVEN COMPRESSOR

BLISSFIELD MANUFACTURING COMPANY

626 DEPOT STREET, BLISSFIELD, MI 49228
PHONE (517)486-2121 FAX 800-336-2547

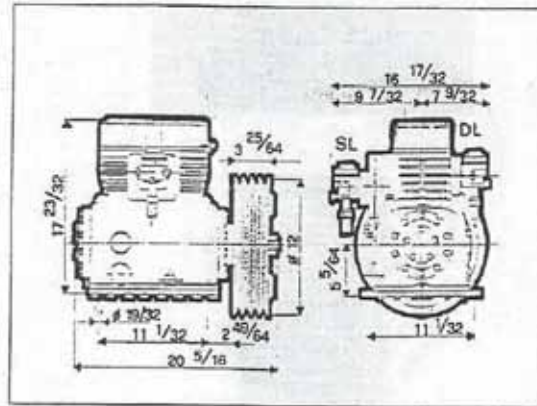

ROTATION: CW OR CCW. CW ROTATION, LOOKING AT SHAFT END
PREFERRED.

FACTORY OIL CHARGE:

51VSM 130 OZ SUNISO 4GS (MINERAL OIL)
E51VSM 130 OZ MOBIL EAL ARCTIC-32 (POE)

FLYWHEEL INSTALLATION: TO INSTALL THE FLYWHEEL, WASH THE FLYWHEEL HUB AND MATING PORTION OF COMPRESSOR SHAFT WITH ALCOHOL AND DRY WELL. INSTALL FLYWHEEL AND TORQUE RETAINING NUT TO 202/210 FT LBS.

CHECK OIL LEVEL: ON NEW INSTALLATIONS OR COMPRESSOR REPLACEMENT INSTALLATIONS, RUN THE SYSTEM FOR APPROXIMATELY ONE HOUR, STOP THE COMPRESSOR AND CHECK THAT THE OIL LEVEL IS AT THE MIDDLE OF THE OIL SIGHT GLASS. REPEAT THIS OIL LEVEL CHECK TWO OR THREE MORE TIMES AT 1/2 HOUR INTERVALS. IF A LOWERING OF THE OIL LEVEL IS OBSERVED, IT WILL BE NECESSARY TO ADD OIL TO BRING THE OIL LEVEL TO THE MIDDLE OF THE SIGHT GLASS. AN OIL LEVEL CHECK SHOULD BE A PART OF A MONTHLY MAINTENANCE PROGRAM. IF EXCESS OIL IS OBSERVED, IT CAN BE REMOVED THRU THE OIL DRAIN HOLE LOCATED AT THE BOTTOM OF THE CRANKCASE BELOW THE REAR MAIN BEARING.

LD17574

FIGURE 17 - COMPRESSOR MAINTENANCE INSTRUCTIONS – 51VSM



LD17577

FIGURE 18 - PHOTO, COMPRESSOR, BELT DRIVEN – 51VSM

TABLE 24 - COMPRESSOR REFRIGERATING CAPACITY – 51VSM: R134A, BTU/HR

MODEL	RPM	C.INCH	HP REQUIRED			CONDENSING TEMPERATURE 104°F						
						EVAPORATING TEMPERATURE °F						
			H	M	L	H			M			L
						50	41	32	23	14	5	-4
51VSM	800	57.91	15	10	7.5	124540	101470	81620	64050	49780	37750	27820
	1000		20	15	10	155690	126850	102030	80050	62220	47190	34780
	1200		20	15	10	186810	152200	122440	96080	74680	56620	41730

TABLE 25 - COMPRESSOR REFRIGERATING CAPACITY – 51VSM: R22, BTU/HR

MODEL	RPM	HP REQUIRED			TC °F	EVAPORATING TEMPERATURE °F									
						H		M			L				
		H	M	L		41	32	23	14	5	-4	-13	-22	-31	-40
		51VSM	800	15		15	15	86	157200	130820	106690	85120	68910	53660	40650
20	15			15	104	142870	113660	91440	73040	59220	43830	33010	23280	16420	11570
20	20			15	122	119390	99730	79080	63520	50650	37610	26520	18710	13180	9290
1000	15		15	15	86	196490	163520	133380	106390	86150	67070	50820	37920	27200	18060
	20		15	15	104	178600	142090	114300	91300	74030	54780	41270	29080	20480	14410
	20		20	20	122	149250	124650	98840	79390	63310	47000	33140	23380	16490	11610
1200	20		20	20	86	235770	196220	160070	127650	103380	80480	60990	45500	32630	21680
	25		20	20	104	214340	170520	137170	109560	88840	65740	49530	34880	24580	17310
	25		25	20	122	179120	149560	118600	95260	75980	56390	39770	28020	19730	13890

TABLE 26 - COMPRESSOR CROSS REFERENCE CHART – 51VSM**CROSS REFERENCE CHART**

(For More Accurate Comparison See Capacity Charts)

HORSE POWER	FRICK BLUE COLD	TECUMSEH	OLD BLISSFIELD	NEW BLISSFIELD	BITZER
1/6 HP				2Q2	0
1/6 HP		1300	CB	2Q3	I
1/4 HP	16436	500	CA	2Q4	II
1/3 HP	16436	1000	CC, CD	2Q5	II
1/2 HP	16436	2300	CE	1HVS	II
3/4 - 1 1/2 HP	16055	HGC850	CG		
1 1/2 - 2 HP	16791			2GVS	III, IV
3 HP	16791	VFT	CH	3LVS	IV, 2T.2-K
3 HEAVY DUTY	16799	VFTL	CJ	3LVS	V
5 - 10 HP	16799	VFTL	CJ	41VSM	V, VI, 2N.2-K
7 1/2 - 15 HP	16799	RA	CK	51VSM	VI, VII, 4T.2K, 4P.2-K, 4N.2-K
10 - 30 HP		SA	CM	62VSC	VII, 4H.2-K, 4G.2-K, 4N.2-K
15 - 40 HP				67VS	6H.2-K, 6G.2-K
20 - 60 HP				80VS	6G.2-K

LD17578

TABLE 27 - COMPRESSOR SPECIFICATIONS – 51VSM**SPECIFICATIONS**

MODEL	HP	BORE	STROKE	MIN RPM	MAX RPM	CYL.	DISP.	SUCTION VALVE	DISCHARGE VALVE	OIL OZ.	WEIGHT LBS.	FLYWHEEL DIA. "IN"	BELT & GROOVES
2Q2	1/6 HP	1 1/2	15/32	500	1500	2	1.66	3/8" FLARE	3/8" FLARE	14	25	5.2	1A
2Q3	1/6 - 1/4 HP	1 1/2	19/32	500	1500	2	2.08	3/8" FLARE	3/8" FLARE	14	25	5.2	1A
2Q4	1/4 - 1/3 HP	1 1/2	3/4	500	1500	2	2.63	1/2" FLARE	1/2" FLARE	14	25	5.2	1A
2Q5	1/3 - 1/2 HP	1 1/2	15/16	500	1500	2	3.32	1/2" FLARE	1/2" FLARE	14	25	5.2	1A
1HVS	1/2 - 1 HP	1 49/64	15/16	500	1450	2	4.64	5/8" FLARE	1/2" FLARE	17	38	6.3	2A
2GVS	1 - 3 HP	2 23/64	1 3/16	500	1450	2	10.34	3/4" FLARE	5/8" FLARE	34	49	6.3	2A
3LVS	3 - 5 HP	2 13/32	2 23/64	500	1300	2	21.4	1 1/8" SF	3/4" FLARE	51	84	10.6	3A
41VSM/ 3B	5 - 10 HP	2 59/64	2 9/16	600	1300	2	34.17	1 3/8" SF	1 1/8" SF	91	209	12	3B
41VSM/ 4B	5 - 10 HP	2 59/64	2 9/16	600	1300	2	34.17	1 3/8" SF	1 1/8" SF	91	209	12	4B
51VSM	7 1/2 - 15 HP	3 15/32	3 5/64	600	1300	2	57.19	1 5/8" SF	1 3/8" SF	130	293	13.2	4B
62VSC/ 6B	10 - 30 HP	3 5/64	2 9/16	750	1750	4	75.97	1 5/8" SF	1 1/8" SF	169	386	12.2	6B
67VS	15 - 40 HP	3 5/16	2 9/16	750	1750	4	87.87	2 1/8" SF	1 3/8" SF	169	435	12.2	6B
80VS	20 - 60 HP	3 5/64	2 9/16	750	1750	4	113.8	2 1/8" SF	1 5/8" SF	203	516	12.2	6B

LD17579

The following factors can be used to convert from English to the most common SI Metric values.

TABLE 28 - SI METRIC CONVERSION

MEASUREMENT	MULTIPLY ENGLISH UNIT	BY FACTOR	TO OBTAIN METRIC UNIT
Capacity	Tons Refrigerant Effect (ton)	3.516	Kilowatts (kW)
Power	Horsepower	0.7457	Kilowatts (kW)
Flow Rate	Gallons / Minute (gpm)	0.0631	Liters / Second (l/s)
Length	Feet (ft)	0.3048	Meters (m)
	Inches (in)	25.4	Millimeters (mm)
Weight	Pounds (lbs)	0.4538	Kilograms (kg)
Velocity	Feet / Second (fps)	0.3048	Meters / Second (m/s)
Pressure Drop	Feet of Water (ft)	2.989	Kilopascals (kPa)
	Pounds / Square Inch (psi)	6.895	Kilopascals (kPa)

Temperature

To convert degrees Fahrenheit (°F) to degrees Celsius (°C), subtract 32° and multiply by 5/9 or 0.5556.

Example: $(45.0^{\circ}\text{F} - 32^{\circ}) \times 0.5556 = 27.2^{\circ}\text{C}$

To convert a temperature range (i.e., a range of 10°F) from Fahrenheit to Celsius, multiply by 5/9 or 0.5556.

Example: $10.0^{\circ}\text{F range} \times 0.5556 = 5.6^{\circ}\text{C range}$



P.O. Box 1592, York, Pennsylvania USA 17405-1592

Copyright © by Johnson Controls 2013

Form 50.40-OM1 (713)

Issue Date: July 17, 2013

:Supersedes: Form 40.40-OM1 (904)

800-861-1001

www.johnsoncontrols.com

Subject to change without notice. Printed in USA

ALL RIGHTS RESERVED