



CORNELL PUMP COMPANY

Refrigerant Pump 2CB

PUMP SPECIFICATION

- 2CB Close coupled refrigerant pump
- 4" x 2" Class 150 Flanged suction & discharge
- Constructed of ASTM A536 60-40-18 Ductile Iron
- Industry leading two year warranty
- Four pole (1800/1500RPM) operating speed
- Optional mounting configurations available
- Polar white
- **Mechanical Seal:**
John Crane, 1.25", T-1, double mechanical shaft seal with pressurized barrier fluid lubrication system, low oil limit switch, and seal chamber heater to maintain proper barrier oil viscosity
- **Motor Specification:**
Close coupled to a totally enclosed fan cooled, refrigerant atmosphere, hostile environment, premium efficiency motor, with class "F" installation; suitable for VFD applications



FEATURES & BENEFITS

- **Refrigerant Emission Free™ Sealing Technology**
 - an ultra-reliable system consisting of two mechanical seals mounted back to back
 - inboard seal prevents escape of refrigerant from the pump casing
 - outboard seal acts as a fail-safe or backup, and provides containment of a system compatible barrier fluid.
- **NPSHR**
 - exceptional NPSHR characteristics
 - characteristics are enhanced throughout entire operating range due to the single stage impeller and four pole operating speed
- **Vapor Entrapment**
 - seals are oil lubricated, and do not rely on the presence of pumpage for lubrication or cooling
 - the double mechanical sealing system allows the pump to continue to run until the system stabilizes and the pump reprimed itself - nuisance-tripping is avoided

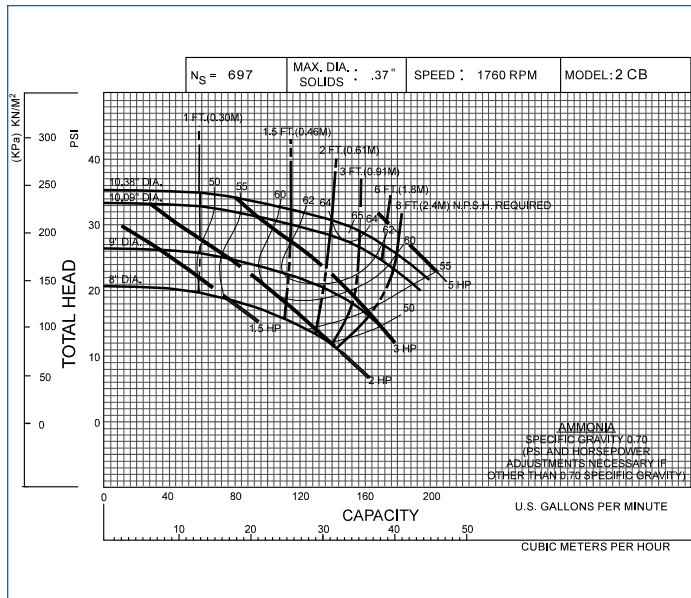

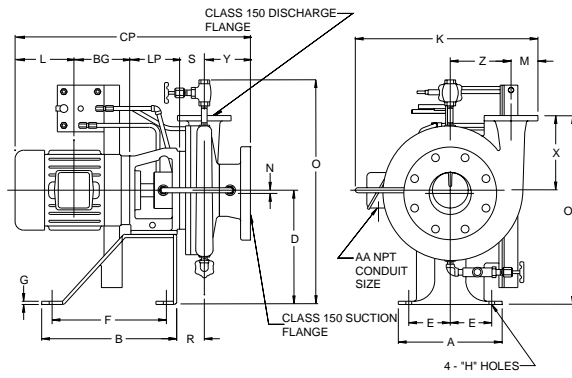

PUMP DIMENSIONS

Model	NEMA Frame	Disch.	Suct.	Type	A	B	D	E	F	G	H	K	M	N	O	R	S	X	Y	Z	LP	OP
2CB	143-184	2.00	4.0	FLG.	10.0	13.0	11.00	4.0	11.0	0.31	0.56	16.50	3.00	0.50	23.50	2.66	2.62	7.50	4.50	5.50	4.56	18.50

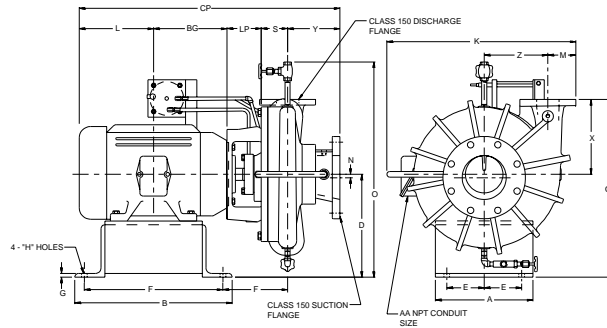

PUMP DIMENSIONS

Model	NEMA Frame	CONNECTION			A	B	D	E	F	G	H	J	K	M	N	O	R	S	X	Y	Z	LP	OP
		Disch.	Suct.	Type																			
2CB	213-215	2.00	4.0	FLG.	13.0	21.0	12.75	5.0	18.50	0.50	0.75	1.25	16.50	3.00	0.50	25.25	5.94	2.62	7.50	4.50	5.50	4.56	20.25

MOTOR DIMENSIONS

HORSEPOWER 1800 RPM	NEMA Frame	L	BG	AA	See Note No. 3
1.0	143	5.75	4.88	0.75	CP=
1.5 - 2.0	145	5.75	4.88	0.75	CP=
3.0 - 5.0	182	7.69	6.25	0.75	CP=
3.0 - 5.0	184	7.69	6.25	0.75	CP=
7.50	213	8.81	8.00	1.00	CP=
10.00	215	8.81	8.00	1.00	CP=

Notes:

1. Motor dimensions are TEFC NEMA Standard
2. Motor dimensions are based on Baldor electric motors; motor dimensions L, BG, & AA may vary for other manufacturers.
3. Dimension "CP" to be filled in after selection of pump and motor.
4. Dimension "O" is 12.12 - inch for 1.5CB and 1.5CLB with 213 frame.

Cornell Pump Company
 P.O. Box 6334
 Portland, Oregon 97228-6334
 Web: www.cornellpump.com
 Phone (503) 653-0330 • Fax (503) 653-0338

ISO9001 CERTIFIED