

MYCOM PRODUCTS HANDBOOK

MAYEKAWA NORTH AMERICA

MAYEKAWA USA OFFICES

Nashville

130 Smart Park Drive
Lebanon, TN 37090
615-773-2859

Seattle

2615 W. Casino Rd., Unit 6F
Everett, WA 98204
425-645-9400

York

3395 Farmtrail Rd.
York, PA 17406
717-779-0138

West Nyack

250 West Nyack Rd., Suite 250
West Nyack, NY 10994
914-301-9770

Torrance

19475 Gramercy Place
Torrance, CA 90501
310-328-1362



MAYEKAWA CANADA OFFICES

Vancouver

4-1595 Cliveden Ave
Delta, BC V3M 6M2
604-270-1544

Calgary

4525 6A Street NA
Calgary, AB T2E 4B2
403-250-1554

Toronto

Unit #1, 1745 Bonhill Road
Mississauga, ON L5T 1C1
905-564-0664

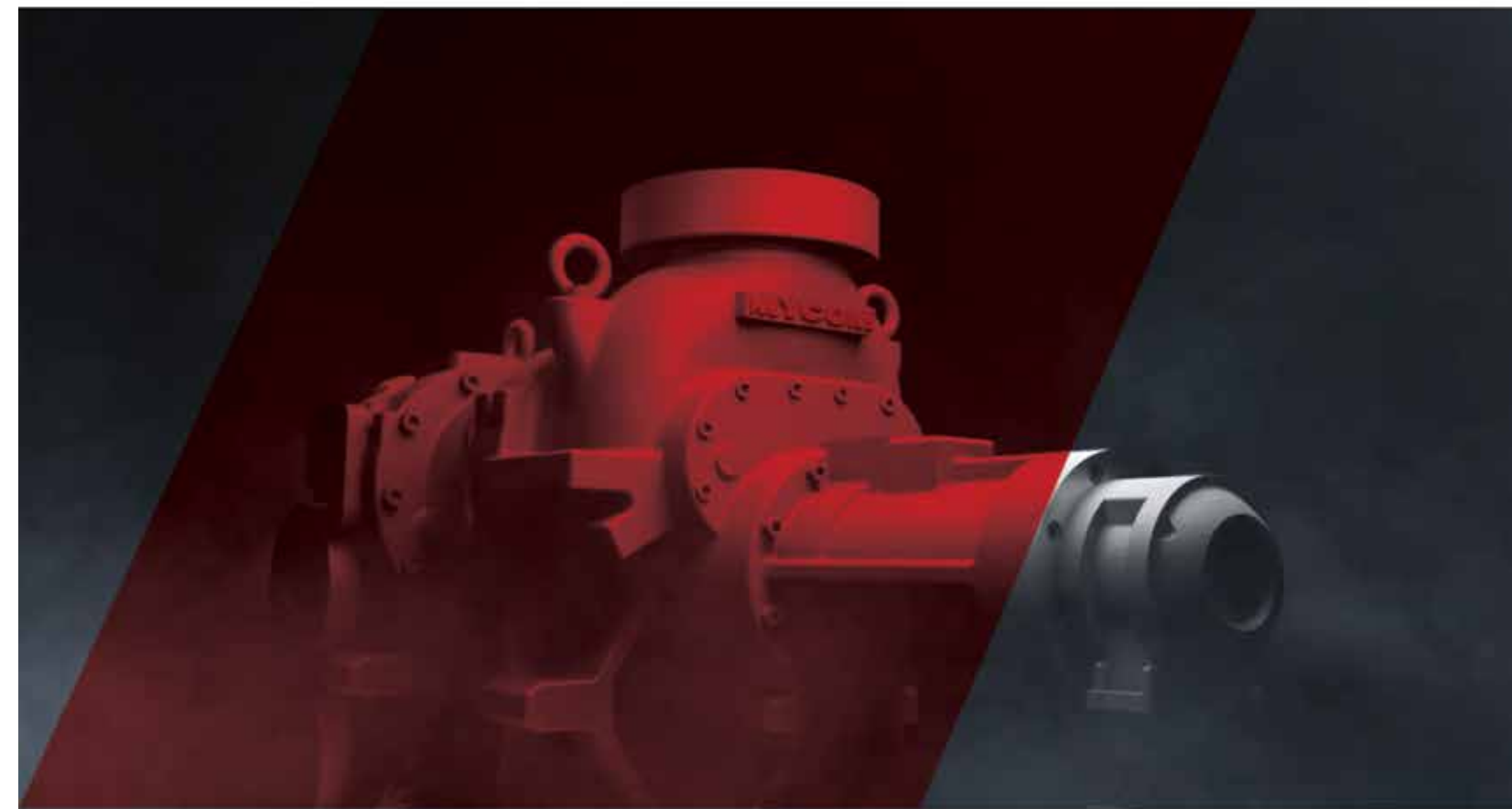

www.mayekawausa.com

Email: info@mayekawausa.com

Service: 855-663-6926

www.mayekawa.ca

Email: customerservice@mayekawa.ca

MAYEKAWA
MYCOM

MYCOM

TABLE OF CONTENTS

| | |
|---------------------------|-------|
| About Mayekawa | 1 |
| Vision | 2 |
| Sales Reps | 3-4 |
| Screw Compressors | 5-6 |
| J-series | 7-8 |
| V-series | 9-10 |
| C-series | 11-12 |
| i-series | 13-14 |
| UD-series | 15-16 |
| MHS-series | 17-18 |
| MYPRO TOUCH+ | 19-20 |
| Reciprocating Compressors | 21-22 |
| M-series | 23-24 |
| K-series | 25-26 |
| HK-series | 27-28 |
| HS-series | 29-30 |
| WBHE-series | 31-32 |
| WA-series | 33-34 |
| L-series | 35-36 |
| MYCORE-RC 100 | 37-38 |
| Oil Pumps | 39-40 |
| MP & FP Oil Pumps | 41-42 |
| OEM Parts | 43-44 |

ABOUT MAYEKAWA

Mayekawa Manufacturing Company has expanded its business by focusing on freezing and compression technologies ever since its establishment in 1924. As a thermal engineering company we have long contributed to providing business solutions to our customers based on these technologies and in turn continuously evolve our products and services. Mayekawa is an industry leader in the manufacturing of MYCOM industrial refrigeration compressors and specialty equipment offering unprecedented levels of energy efficient savings solutions. Mayekawa's name has been synonymous for reliability, quality and innovation globally. Today, we have locations in more than 32 countries.

Mayekawa has been manufacturing compressors since 1924 in Japan and 1967 in the United States. Mayekawa USA has been involved in the design and manufacturing of state-of-the-art screw and reciprocating compressor packages for commercial and industrial applications throughout the world.

“ MYCOM compressors deliver energy efficient, low maintenance and cost effective solutions. ”



VISION

Mayekawa strives to focus on growing its business to become the #1 compressor maker in the Americas by delivering innovative solutions and a strong relationship with its customers and suppliers. Through this method, Mayekawa strives to become the “Only ONE” choice in the industry.

SALES REPS

USA SALES REP OFFICES

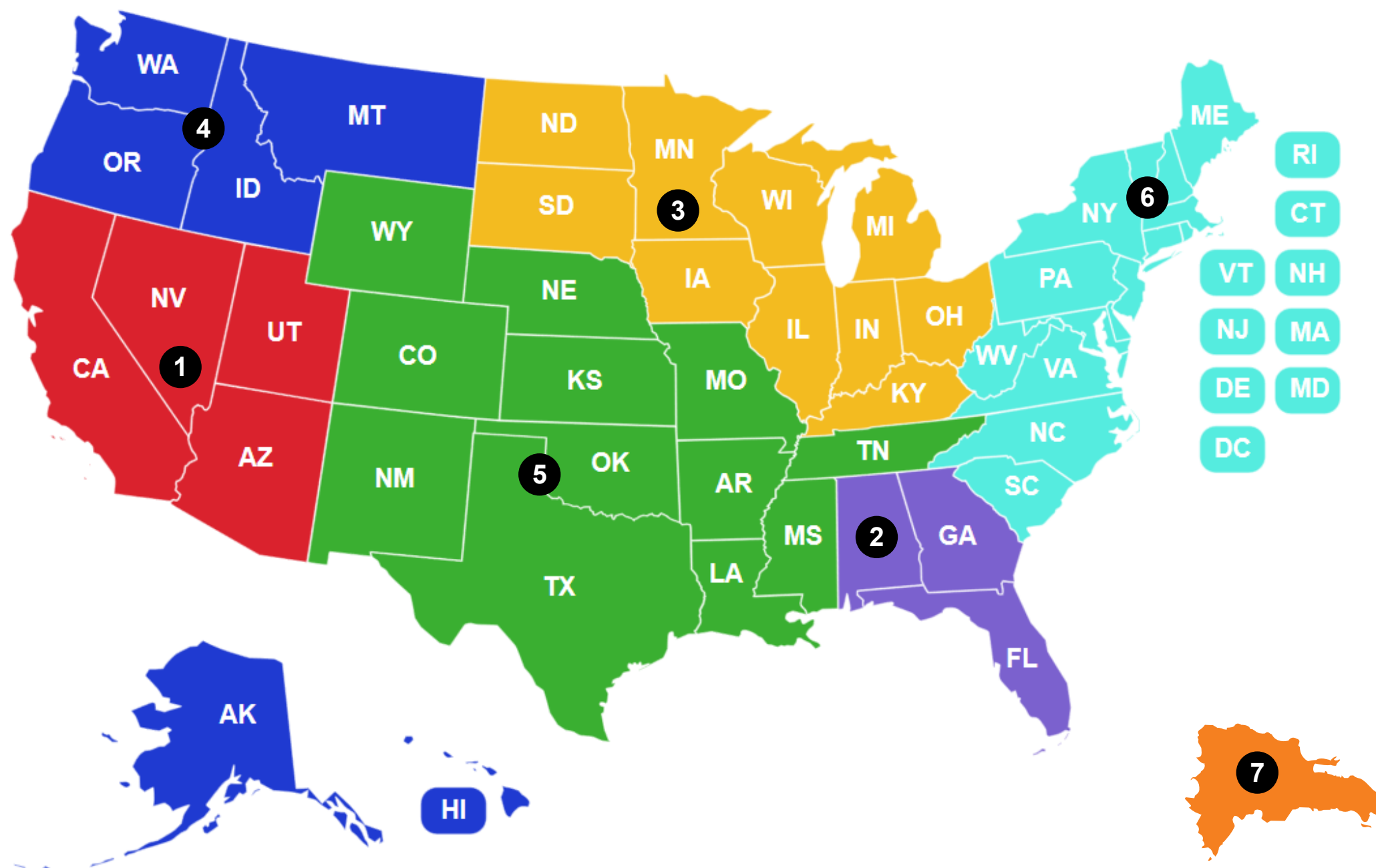

- 1** **Clark Johnson Company, Inc.**
 14747 Artesia Blvd, 2-E
 La mirada, CA 90638
 714-521-6161
- 2** **Freeze-Pro, Inc.**
 3516 Enterprise Way, Suite 3
 Green Cover Springs, FL 32043
 904-531-5065
- 3** **Stanton & Associates, Inc.**
 6910 N. Main Street, Unit 15
 Granger, IN 46530
 574-247-5522
- 4** **IREP**
 1540 NE 95th Street
 Seattle, WA 98115
 206-941-8095 or 604-219-6049
- 5** **South West Refrigeration Sales, SWR Sales, LLC.**
 19141 Stone Oak Pkwy #104
 San Antonio, TX 78258
 210-492-8024
- 6** **James Buffington**
 130 Smart Park Drive
 Lebanon, TN 37090
 615-773-2859
- 7** **Luis Popa**
 C/ Rubén Dario No. 25, Ens. Enriquillo
 Herrera, Santo Domingo Oeste, R.D.
 809-271-5507

SCREW COMPRESSORS

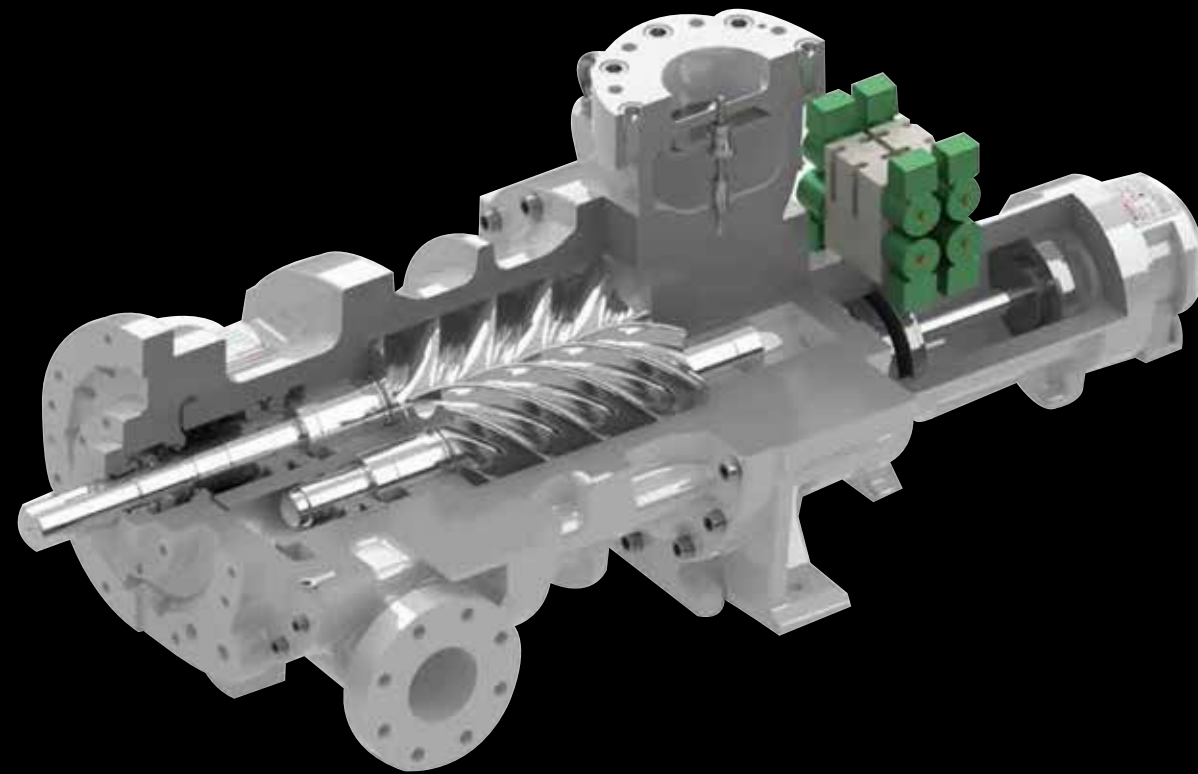

- J-series
- V-series
- C-series
- i-series
- UD-series
- MHS-series

Mayekawa started manufacturing MYCOM Screw Compressors in 1964. Since then, Mayekawa has achieved to produce high-performance and high-efficiency compressors by developing its own manufacturing skills and rotor lobe designs. Mayekawa's screw compressors are designed for durability, low-noise and low-vibration to offer packaged solutions.

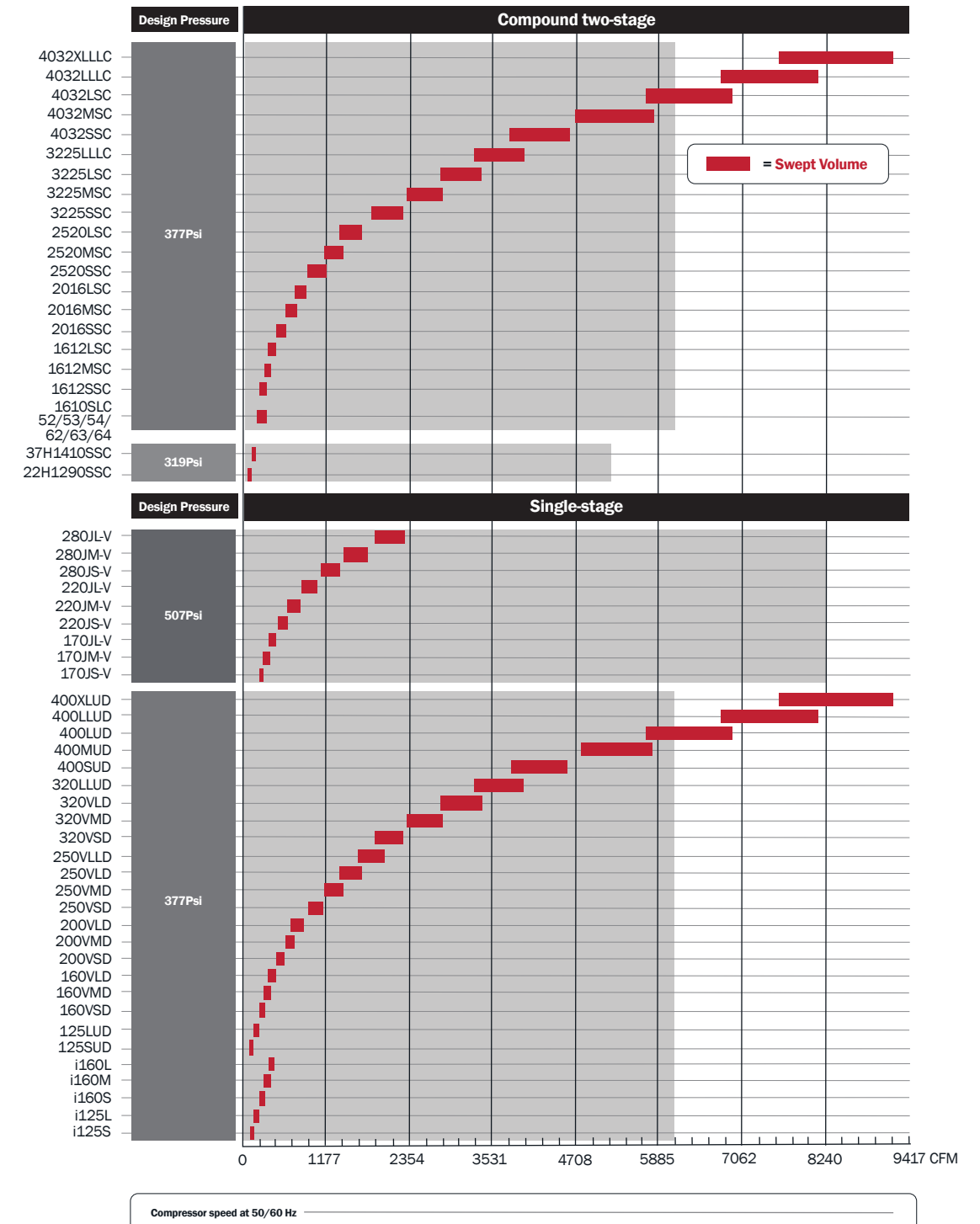

J-SERIES

Screw Compressor [Single Stage] Open Type



High Performance Derived from New Design

The series is intended to be the standard for next-generation compressors in industrial fields.

Adoption of New-Type Rotor

The newly developed J-profile rotor design, consisting of a 5:6 lobe configuration, enables to achieving high-performance.

Rich in Variation

Natural refrigerants (e.g. ammonia, CO₂, propane) and fluorocarbon refrigerants can be used. Flexible setup of applications is possible.

Low Vibration and Low Noise

* Noise level reduced by 5 dB compared to a conventional machine type.

Stepless Capacity Control from 100% to 25% Range

Due to the stepless control feature, the series optimally operates in accordance with the required load and delivers high energy-saving performance.

Automatically Variable Vi Mechanism (2.5-5.0 range) to Efficiently Cover Wide Temperature Range

Supports Flange Motors to Facilitate Design of Packaged Systems

The built-in check valve as well as the compatibility with flange motors help reduce cost for designing packaged systems while contributing to space saving.

* The 280J has no built-in check valve and thus does not support flange motors.

Performance charts

| Refrigerant | | Ammonia | | | | CO ₂ | | Propane | | R404A | | | R134a | | |
|-----------------------|------------------|--|---------|---|----------|---|----------|---|----------|--|---------|---|----------|---|----------|
| Temperature condition | Model | -40/+35°C • -40/+95°F | | -10/+35°C • +14/+95°F | | -50/+10°C • -58/+14°F | | -10/+35°C • +14/+95°F | | -40/+35°C • -40/+95°F | | 0/+40°C • +32/+104°F | | +2/+42°C • +36/+108°F | |
| | | Liquid Subcooling: 5°C/9°F Suction Superheat: 0°C/0°F Rotation speed: 2950rpm Economizer-type | | Liquid Subcooling: 5°C/9°F Suction Superheat: 0°C/0°F Rotation speed: 2950rpm | | Liquid Subcooling: 0°C/0°F Suction Superheat: 0°C/0°F Rotation speed: 2950rpm | | Liquid Subcooling: 5°C/9°F Suction Superheat: 10°C/18°F Rotation speed: 2950rpm | | Liquid Subcooling: 5°C/9°F Suction Superheat: 25°C/45°F Rotation speed: 2950rpm Economizer-type | | Liquid Subcooling: 5°C/9°F Suction Superheat: 25°C/45°F Rotation speed: 2950rpm | | Liquid Subcooling: 5°C/9°F Suction Superheat: 25°C/45°F Rotation speed: 2950rpm | |
| 170JS-V | Cooling Capacity | 21.2RT | 74.5kW | 73.5RT | 258.7kW | 118.5RT | 416.7kW | 58.6RT | 206.2kW | 24.6RT | 86.7kW | 85.5RT | 300.9kW | 58.5RT | 206.7kW |
| | Absorbed Power | 67.5HP | 50.3kW | 88.1HP | 65.7kW | 187.2HP | 139.6kW | 78.4HP | 58.5kW | 86.4HP | 64.4kW | 119.1HP | 88.8kW | 66.2HP | 49.4kW |
| 170JM-V | Cooling Capacity | 27.4RT | 96.4kW | 95.5RT | 335.8kW | 153.7RT | 540.7kW | 76.1RT | 267.6kW | 31.1RT | 109.3kW | 111.0RT | 390.5kW | 76.2RT | 268.2kW |
| | Absorbed Power | 85.0HP | 63.4kW | 113.9HP | 84.9kW | 245.3HP | 182.9kW | 101.5HP | 75.7kW | 107.7HP | 80.3kW | 152.1HP | 113.4kW | 84.5HP | 63.0kW |
| 170JL-V | Cooling Capacity | 35.8RT | 125.9kW | 124.4RT | 437.5kW | 200.2RT | 704.3kW | 99.1RT | 348.5kW | 39.3RT | 138.1kW | 144.6RT | 508.7kW | 99.3RT | 349.4kW |
| | Absorbed Power | 108.8HP | 81.1kW | 146.3HP | 109.1kW | 317.4HP | 236.7kW | 130.6HP | 97.4kW | 135.3HP | 100.9kW | 195.5HP | 145.8kW | 108.4HP | 80.8kW |
| 220JS-V | Cooling Capacity | 50.4RT | 177.3kW | 169.2RT | 595.3kW | 280.8RT | 987.7kW | 137.2RT | 482.7kW | 55.8RT | 196.4kW | 186.7RT | 656.7kW | 128.6RT | 452.5kW |
| | Absorbed Power | 156.0HP | 116.3kW | 204.0HP | 152.1kW | 447.4HP | 333.6kW | 180.2HP | 134.4kW | 207.7HP | 154.9kW | 285.5HP | 212.9kW | 155.8HP | 116.2kW |
| 220JM-V | Cooling Capacity | 65.5RT | 230.3kW | 219.6RT | 772.3kW | 364.1RT | 1280.8kW | 177.9RT | 625.9kW | 72.6RT | 255.2kW | 242.2RT | 851.8kW | 166.8RT | 586.8kW |
| | Absorbed Power | 197.4HP | 147.2kW | 258.3HP | 192.6kW | 569.8HP | 424.9kW | 227.8HP | 169.9kW | 266.3HP | 198.6kW | 367.4HP | 274.0kW | 199.3HP | 148.6kW |
| 220JL-V | Cooling Capacity | 85.7RT | 301.4kW | 286.9RT | 1009.3kW | 475.7RT | 1673.1kW | 232.4RT | 817.6kW | 95.0RT | 334.2kW | 316.5RT | 1113.2kW | 218.0RT | 766.7kW |
| | Absorbed Power | 254.1HP | 189.5kW | 330.6HP | 246.5kW | 729.9HP | 544.3kW | 290.2HP | 216.4kW | 349.9HP | 260.9kW | 483.4HP | 360.5kW | 258.9HP | 193.1kW |
| 280JS-V | Cooling Capacity | 119.3RT | 419.5kW | 386.4RT | 1359.0kW | 636.1RT | 2237.4kW | 303.0RT | 1065.7kW | 132.1RT | 464.8kW | 431.4RT | 1517.3kW | 290.0RT | 1020.0kW |
| | Absorbed Power | 340.9HP | 254.2kW | 442.7HP | 330.1kW | 972.8HP | 725.4kW | 392.5HP | 292.7kW | 457.5HP | 341.2kW | 625.3HP | 466.3kW | 343.2HP | 255.9kW |
| 280JM-V | Cooling Capacity | 154.7RT | 544.1kW | 500.8RT | 1761.6kW | 824.6RT | 2900.3kW | 392.8RT | 1381.5kW | 171.4RT | 602.9kW | 559.2RT | 1967.0kW | 376.0RT | 1322.4kW |
| | Absorbed Power | 425.2HP | 317.1kW | 554.6HP | 413.6kW | 1232.0HP | 918.7kW | 493.6HP | 368.1kW | 576.4HP | 429.8kW | 792.1HP | 590.7kW | 435.3HP | 324.6kW |
| 280JL-V | Cooling Capacity | 201.6RT | 709.0kW | 652.1RT | 2293.7kW | 1073.6RT | 3776.2kW | 511.4RT | 1798.7kW | 223.3RT | 785.4kW | 728.2RT | 2561.3kW | 489.5RT | 1721.8kW |
| | Absorbed Power | 532.8HP | 397.3kW | 696.5HP | 519.4kW | 1559.4HP | 1162.9kW | 622.1HP | 463.9kW | 732.9HP | 546.5kW | 1011.8HP | 754.5kW | 556.8HP | 415.2kW |

* Please consult us for further details.

Specifications

| Item | | Model (N/C/P/F) ^{*1} | | 170J | | | 220J | | | 280J | | |
|--------------------------|---------|---|-----|------|--------------|------|------|----------------|------|------|------|--|
| | | S-V | M-V | L-V | S-V | M-V | L-V | S-V | M-V | L-V | | |
| Refrigerant | | Ammonia / CO ₂ / Propane, Propylene / HFCs | | | | | | | | | | |
| Theoretical displacement | 2950rpm | CFM | 230 | 298 | 388 | 504 | 656 | 852 | 1110 | 1443 | 1878 | |
| | 3550rpm | CFM | 276 | 359 | 467 | 606 | 789 | 1025 | 1335 | 1736 | 2260 | |
| Theoretical displacement | 2950rpm | m ³ /h | 390 | 507 | 659 | 856 | 1114 | 1447 | 1886 | 2451 | 3190 | |
| | 3550rpm | m ³ /h | 469 | 610 | 793 | 1030 | 1340 | 1741 | 2269 | 2949 | 3839 | |
| Minimum rotation speed | rpm | 1450 ^{*2} | | | | | | | | | | |
| Maximum rotation speed | rpm | 4500 ^{*2} | | | | | | | | | | |
| Rotation direction | | CCW as viewed from motor | | | | | | | | | | |
| Capacity control | % | 25-100 | | | | | | 30-100 | | | | |
| Gas inlet port | | ANSI #300 5" | | | ANSI #300 8" | | | ANSI #300 12" | | | | |
| Gas outlet port | | ANSI #300 3" | | | ANSI #300 5" | | | ANSI #300 8" | | | | |
| Flange motor connection | NEMA | 44*D / 50*D | | | 44*D / 50*D | | | Not compatible | | | | |
| | IEC | FF500 / 600 | | | FF500 / 600 | | | | | | | |

* 1. Specify the refrigerant by adding a prefix to the model code (N = ammonia / C = CO₂ / P = propane, propylene / F = fluorocarbons).

* 2. The range of rotation speed varies by operating conditions. Please refer to the ranges of use stated in the operating instructions.

Outer dimensions

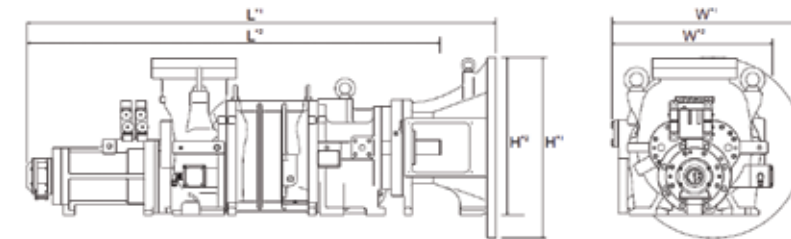

| Model | Weight | W | L | H |
|-----------------------|---------------|-----------|------------|-----------|
| 170JS-V ^{*1} | 1929lb/875kg | 26"/669mm | 63"/1599mm | 26"/660mm |
| 170JM-V ^{*1} | 1995lb/905kg | 26"/669mm | 65"/1654mm | 26"/660mm |
| 170JL-V ^{*1} | 2094lb/950kg | 26"/669mm | 68"/1726mm | 26"/660mm |
| 220JS-V ^{*1} | 3307lb/1500kg | 34"/859mm | 76"/1935mm | 32"/810mm |
| 220JM-V ^{*1} | 3439lb/1560kg | 34"/859mm | 79"/2007mm | 32"/810mm |
| 220JL-V ^{*1} | 3594lb/1630kg | 34"/859mm | 83"/2100mm | 32"/810mm |
| 280JS-V ^{*2} | 5071lb/2300kg | 35"/896mm | 83"/2112mm | 32"/812mm |
| 280JM-V ^{*2} | 5401lb/2450kg | 35"/896mm | 87"/2205mm | 32"/812mm |
| 280JL-V ^{*2} | 5732lb/2600kg | 35"/896mm | 92"/2328mm | 32"/812mm |

* The outer dimension drawings illustrate the model 220JL with an IEC FF600 motor spacer.

* 1. Models 170-220JS/JM/JL include an IEC FF600 flange motor connection. * 2. Models 280JS/JM/JL do not support flange motor spacers.

* Please consult us for further details.

V-SERIES

Screw Compressor [Single Stage] Open Type



Variable Vi Mechanism (2.63-5.80 range) to Efficiently Cover a Wide Temperature Range

Offers a Wide Range of Capacities

Available in 13 models, the V-series covers a wide displacement range from 244CFM to 2790CFM (415 m³/h to 4740 m³/h).

* At 2950 rpm

Applications

Operates over a wide range of temperature and serves in industrial refrigeration, freezing and air conditioning applications. Also workable as a booster compressor.

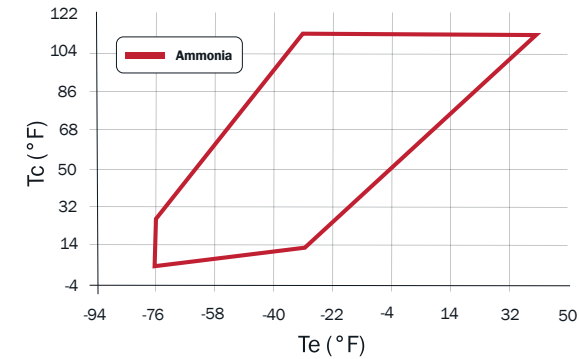

* The temperature range varies by model.

Longtime Seller

With a proven 4:6 rotor configuration, the V-series offers optimal performance to customers.

Specifications

| Item | Model (N/P/F) ^{*1*2} | | 160V | | | 200V | | | 250V | | | | 320V | | |
|--------------------------|-------------------------------------|--------------------|------|---------------------------|-----|------|---------------------------|------|------|------|---------------------------|------|------|------|------|
| | SD | MD | LD | SD | MD | LD | SD | MD | LD | LLD | SD | MD | LD | | |
| Refrigerant | Ammonia / Propane, Propylene / HFCs | | | | | | | | | | | | | | |
| Theoretical displacement | 2950rpm | CFM | 244 | 305 | 366 | 477 | 600 | 712 | 930 | 1165 | 1389 | 1648 | 1866 | 2331 | 2790 |
| | 3550rpm | CFM | 294 | 367 | 441 | 574 | 718 | 859 | 1118 | 1401 | 1672 | 1984 | 2248 | 2802 | 3355 |
| Theoretical displacement | 2950rpm | m ³ /h | 415 | 519 | 622 | 810 | 1020 | 1210 | 1580 | 1980 | 2360 | 2800 | 3170 | 3960 | 4740 |
| | 3550rpm | m ³ /h | 499 | 624 | 749 | 975 | 1220 | 1460 | 1900 | 2380 | 2840 | 3370 | 3820 | 4760 | 5700 |
| Minimum rotation speed | rpm | 1450 ^{*3} | | | | | | | | | | | | | |
| Maximum rotation speed | rpm | 4500 ^{*3} | | | | | | | | | | | | | |
| Rotation direction | CCW as viewed from motor | | | | | | | | | | | | | | |
| Capacity control | % | 30-100 | | | | | | | | | | | | | |
| Gas inlet port | MYCOM 125A ^{*4} | | | MYCOM 150A ^{*4} | | | MYCOM 250A ^{*4} | | | | MYCOM 350A ^{*4} | | | | |
| Gas outlet port | MYCOM 100CD ^{*4} | | | MYCOM 125CD ^{*4} | | | MYCOM 150CD ^{*4} | | | | MYCOM 200CD ^{*4} | | | | |

- * 1. Specify the refrigerant by adding a prefix to the model code (N = ammonia / P = propane, propylene / F = fluorocarbons).
- * 2. Please contact us separately for models with a designation ending with G (downward discharge).
- * 3. The range of rotation speed varies by operating conditions. Please refer to the ranges of use stated in the operating instructions.
- * 4. Flanges with a designation starting with MYCOM are in-house products of MYCOM.

Performance charts

| Refrigerant | Temperature condition | Ammonia | | | | Propane | | R404A | | | | R134a | | | |
|-------------|-----------------------|--|---|---|---|--|--|---|---|---|---|---|---|--------------------|---------------------|
| | | -40/+35°C • -40/+95°F | -40/+10°C • -40/+14°F | -10/+35°C • +14/+95°F | -10/+35°C • +14/+95°F | -10/+35°C • +14/+95°F | -40/+35°C • -40/+95°F | 0/+40°C • +32/+104°F | +2/+42°C • +36/+108°F | | | | | | |
| Model | | Liquid Subcooling: 5°C/9°F Suction Superheat: 0°C/0°F Rotation speed: 2950rpm Economizer-type | Liquid Subcooling: 5°C/9°F Suction Superheat: 0°C/0°F Rotation speed: 2950rpm | Liquid Subcooling: 5°C/9°F Suction Superheat: 0°C/0°F Rotation speed: 2950rpm | Liquid Subcooling: 5°C/9°F Suction Superheat: 0°C/0°F Rotation speed: 2950rpm | Liquid Subcooling: 5°C/9°F Suction Superheat: 25°C/45°F Rotation speed: 2950rpm Economizer-type | Liquid Subcooling: 5°C/9°F Suction Superheat: 25°C/45°F Rotation speed: 2950rpm Economizer-type | Liquid Subcooling: 5°C/9°F Suction Superheat: 25°C/45°F Rotation speed: 2950rpm | Liquid Subcooling: 5°C/9°F Suction Superheat: 25°C/45°F Rotation speed: 2950rpm | Liquid Subcooling: 5°C/9°F Suction Superheat: 25°C/45°F Rotation speed: 2950rpm | Liquid Subcooling: 5°C/9°F Suction Superheat: 25°C/45°F Rotation speed: 2950rpm | Liquid Subcooling: 5°C/9°F Suction Superheat: 25°C/45°F Rotation speed: 2950rpm | Liquid Subcooling: 5°C/9°F Suction Superheat: 25°C/45°F Rotation speed: 2950rpm | | |
| | | Cooling Capacity | Absorbed Power | Cooling Capacity | Absorbed Power | Cooling Capacity | Absorbed Power | Cooling Capacity | Absorbed Power | Cooling Capacity | Absorbed Power | Cooling Capacity | Absorbed Power | | |
| 160VSD/G | | 21.4RT 71.6HP | 75.2kW 53.4kW | 23.7RT 27.0HP | 83.4kW 20.1kW | 77.6RT 99.6HP | 272.9kW 74.3kW | 62.5RT 91.6HP | 219.9kW 68.3kW | 25.3RT 97.2HP | 89.0kW 72.5kW | 94.9RT 132.5HP | 333.9kW 98.8kW | 62.1RT 75.0HP | 218.6kW 55.9kW |
| 160VMD/G | | 26.7RT 86.5HP | 94.0kW 64.5kW | 30.0RT 33.0HP | 105.4kW 24.6kW | 97.1RT 120.0HP | 341.6kW 89.5kW | 78.4RT 110.4HP | 275.8kW 82.3kW | 31.5RT 117.1HP | 110.9kW 87.3kW | 119.0RT 159.6HP | 418.5kW 119.0kW | 78.4RT 92.0HP | 275.6kW 68.6kW |
| 160VLD/G | | 32.0RT 102.7HP | 112.6kW 76.6kW | 36.2RT 39.6HP | 127.5kW 29.5kW | 116.4RT 142.5HP | 409.4kW 106.3kW | 94.1RT 131.0HP | 331.1kW 97.7kW | 37.9RT 138.8HP | 133.2kW 103.5kW | 142.8RT 189.6HP | 502.4kW 141.4kW | 94.6RT 110.4HP | 332.8kW 82.3kW |
| 200VSD/G | | 42.5RT 138.9HP | 149.6kW 103.6kW | 48.8RT 52.6HP | 171.6kW 39.2kW | 153.3RT 192.8HP | 539.8kW 143.8kW | 122.9RT 177.3HP | 432.2kW 132.2kW | 50.7RT 188.8HP | 178.4kW 140.8kW | 186.4RT 256.4HP | 655.6kW 191.2kW | 125.1RT 146.4HP | 439.9kW 109.2kW |
| 200VMD/G | | 53.9RT 169.5HP | 189.5kW 126.4kW | 61.5RT 65.3HP | 216.2kW 48.7kW | 194.2RT 234.8HP | 683.1kW 175.1kW | 155.2RT 216.0HP | 546.0kW 161.1kW | 63.4RT 229.6HP | 223.0kW 171.2kW | 235.4RT 312.5HP | 828.1kW 233.0kW | 158.7RT 181.8HP | 558.2kW 135.6kW |
| 200VLD/G | | 65.2RT 201.2HP | 229.4kW 150.0kW | 73.9RT 77.5HP | 260.0kW 57.8kW | 234.6RT 278.5HP | 825.3kW 207.7kW | 187.2RT 256.1HP | 658.5kW 191.0kW | 76.1RT 272.0HP | 267.8kW 202.8kW | 283.9RT 370.5HP | 998.6kW 276.3kW | 189.6RT 215.8HP | 667.0kW 160.9kW |
| 250VSD/G | | 86.1RT 264.3HP | 302.7kW 197.1kW | 96.7RT 102.5HP | 340.0kW 76.4kW | 305.3RT 365.0HP | 1073.7kW 272.2kW | 244.8RT 335.7HP | 860.9kW 250.3kW | 102.1RT 359.5HP | 359.0kW 268.1kW | 371.1RT 485.6HP | 1305.3kW 362.1kW | 248.3RT 285.5HP | 873.2kW 212.9kW |
| 250VMD/G | | 108.3RT 325.3HP | 380.8kW 242.6kW | 121.8RT 126.1HP | 428.4kW 94.0kW | 383.5RT 449.1HP | 1349.1kW 334.9kW | 308.3RT 412.9HP | 1084.4kW 307.9kW | 127.2RT 440.8HP | 447.4kW 328.7kW | 467.3RT 597.3HP | 1643.8kW 445.4kW | 311.1RT 351.2HP | 1094.3kW 261.9kW |
| 250VLD/G | | 129.7RT 387.8HP | 456.1kW 289.2kW | 145.8RT 150.5HP | 513.0kW 112.2kW | 458.1RT 535.6HP | 1611.5kW 399.4kW | 369.2RT 492.5HP | 1298.5kW 367.3kW | 151.6RT 524.5HP | 533.4kW 391.1kW | 559.5RT 712.6HP | 1968.1kW 531.4kW | 370.8RT 418.9HP | 1304.3kW 312.4kW |
| 250VLLD | | 152.5RT 457.3HP | 536.4kW 341.0kW | 172.5RT 178.0HP | 606.9kW 132.7kW | 542.0RT 633.6HP | 1906.4kW 472.5kW | 436.7RT 582.8HP | 1536.0kW 434.6kW | 186.4RT 567.5HP | 655.7kW 423.2kW | 768.3RT 687.0HP | 2702.3kW 512.3kW | 440.0RT 495.6HP | 1547.5kW 369.6kW |
| 320VSD | | 174.7RT 530.9HP | 614.4kW 395.9kW | 195.5RT 205.7HP | 687.7kW 153.4kW | 614.1RT 732.3HP | 2160.1kW 546.1kW | 494.8RT 673.5HP | 1740.5kW 502.2kW | 207.3RT 721.9HP | 729.1kW 538.3kW | 750.0RT 974.2HP | 2638.1kW 726.5kW | 498.1RT 572.9HP | 1752.0kW 427.2kW |
| 320VMD | | 217.3RT 655.2HP | 764.3kW 488.6kW | 243.9RT 254.1HP | 857.9kW 189.5kW | 766.2RT 904.8HP | 2695.0kW 674.7kW | 617.4RT 832.1HP | 2171.5kW 620.5kW | 255.4RT 887.6HP | 898.4kW 661.9kW | 935.7RT 1203.5HP | 3291.3kW 897.5kW | 622.2RT 707.6HP | 2188.6kW 527.7kW |
| 320VLD | | 254.9RT 769.2HP | 896.5kW 573.6kW | 286.6RT 298.5HP | 1008.1kW 222.6kW | 900.2RT 1062.9HP | 3166.5kW 792.6kW | 725.4RT 977.5HP | 2551.4kW 728.9kW | 298.5RT 1040.3HP | 1050.0kW 775.8kW | 1099.4RT 1413.8HP | 3867.2kW 1054.3kW | 739.1RT 831.3HP | 2599.6kW 619.9kW |

* The machine cannot be used under certain conditions. Please consult us for further details.

Outer dimensions

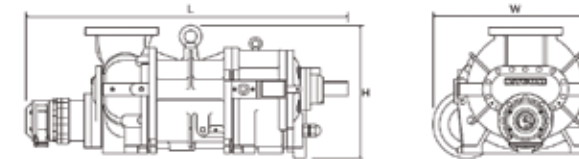

| Model | Weight | W | L | H | |
|-------|--------|---------------|-----------|------------|-----------|
| 160V | SD | 816lb/370kg | 19"/470mm | 41"/1029mm | 17"/431mm |
| | MD | 838lb/380kg | 19"/470mm | 42"/1074mm | 17"/431mm |
| | LD | 860lb/390kg | 19"/470mm | 44"/1119mm | 17"/431mm |
| 200V | SD | 1389lb/630kg | 26"/657mm | 47"/1201mm | 21"/540mm |
| | MD | 1477lb/670kg | 26"/657mm | 50"/1258mm | 21"/540mm |
| | LD | 1543lb/700kg | 26"/657mm | 52"/1313mm | 21"/540mm |
| 250V | SD | 2601lb/1180kg | 31"/789mm | 55"/1397mm | 26"/655mm |
| | MD | 2690lb/1220kg | 31"/789mm | 58"/1469mm | 26"/655mm |
| | LD | 2866lb/1300kg | 31"/789mm | 61"/1537mm | 26"/655mm |
| | LLD | 3064lb/1390kg | 31"/789mm | 64"/1615mm | 26"/655mm |
| 320V | SD | 4938lb/2240kg | 39"/996mm | 71"/1798mm | 34"/861mm |
| | MD | 5467lb/2480kg | 39"/996mm | 74"/1886mm | 34"/861mm |
| | LD | 5820lb/2640kg | 39"/996mm | 78"/1973mm | 34"/861mm |

* The outer dimension drawings illustrate the model 200VLD. * Please contact us separately for models with a designation ending with G (downward discharge).
* Please consult us for further details.

C-SERIES

Screw Compressor [Two Stage] Open Type



Single Machine / Two-stage Compression to Efficiently Cover Low Temperature Ranges

Wide-ranging Lineup

Available in 6 models with different rotor diameter configurations to cover a wide displacement* range from 216 CFM to 1866CFM (367 m³/h to 9,700 m³/h).

* This catalog lists representative models combined with standard rotor length. Please contact us separately for available variants.

MYCOM's Unique Industrial Compound Compressor

Needs only one motor and oil separator and thus contributes to space saving.

Longtime Seller

A lineup of medium - to large - sized two-stage compressors with a proven 4:6 rotor configuration.

Performance charts

| Refrigerant | | Ammonia | | R404A | |
|--------------------------|------------------|--|----------|--|----------|
| | | -40/+35°C • -40/+95°F | | -40/+35°C • -40/+95°F | |
| Temperature condition | | Liquid Subcooling: 5°C/ 9°F Suction Superheat: 0°C/0°F Rotation speed: 2950rpm | | Liquid Subcooling: 5°C/ 9°F Suction Superheat: 20°C/36°F Rotation speed: 2950rpm | |
| Model | | | | | |
| 1610SLC-52 ^{*1} | Cooling Capacity | 18.5RT | 65.2kW | 22.3RT | 78.5kW |
| | Absorbed Power | 57.4HP | 42.8kW | 78.9HP | 58.8kW |
| 1612LSC | Cooling Capacity | 32.4RT | 114.1kW | 38.6RT | 135.7kW |
| | Absorbed Power | 90.5HP | 67.5kW | 127.3HP | 94.9kW |
| 2016LSC | Cooling Capacity | 66.6RT | 234.4kW | 80.0RT | 281.4kW |
| | Absorbed Power | 181.0HP | 135.0kW | 253.2HP | 188.8kW |
| 2520LSC | Cooling Capacity | 131.6RT | 462.8kW | 157.8RT | 555.2kW |
| | Absorbed Power | 351.2HP | 261.9kW | 490.9HP | 366.1kW |
| 3225LSC | Cooling Capacity | 258.7RT | 909.8kW | 311.2RT | 1094.7kW |
| | Absorbed Power | 678.7HP | 506.1kW | 949.7HP | 708.2kW |
| 4032LSC | Cooling Capacity | 529.2RT | 1861.4kW | 632.5RT | 2224.9kW |
| | Absorbed Power | 1415.8HP | 1055.8kW | 2003.9HP | 1494.3kW |

*1. Values at 1450 rpm are listed for the 1610SLC-52.

* The machine cannot be used under certain conditions. Please consult us for further details.

Specifications

| Item | Model (N/F) ^{*1} | | 1610SLC-52 ^{*2} | | 1612LSC | | 2016LSC | | 2520LSC | | 3225LSC | | 4032LSC | |
|--------------------------|---------------------------|-------------------|--------------------------|-------------------|-------------|------------|-------------|------------|-------------|------------|--------------|------------|-----------|------------|
| | Low Stage | High Stage | Low Stage | High Stage | Low Stage | High Stage | Low Stage | High Stage | Low Stage | High Stage | Low Stage | High Stage | Low Stage | High Stage |
| Refrigerant | Ammonia / HFC | | | | | | | | | | | | | |
| Theoretical displacement | 2950rpm | CFM | 216 | 79 | 366 | 116 | 712 | 305 | 1389 | 477 | 2790 | 930 | 5709 | 1866 |
| | 3550rpm | CFM | 216 | 79 | 441 | 139 | 859 | 294 | 1672 | 574 | 3355 | 1118 | 6886 | 2248 |
| Theoretical displacement | 2950rpm | m ³ /h | 367 ^{*3} | 135 ^{*3} | 622 | 197 | 1210 | 519 | 2360 | 810 | 4740 | 1580 | 9700 | 3170 |
| | 3550rpm | m ³ /h | 367 ^{*4} | 135 ^{*4} | 749 | 237 | 1460 | 499 | 2840 | 975 | 5700 | 1900 | 11700 | 3820 |
| Minimum rotation speed | rpm | 1450 | | | | | | | | | | | | |
| Maximum rotation speed | rpm | 1450 | | 4500 | | | | 3600 | | | | | | |
| Rotation direction | CW as viewed from motor | | CCW as viewed from motor | | | | | | | | | | | |
| Capacity control | % | 30 - 100 | | | | | | | | | | | | |
| Gas inlet port | MYCOM 125A ^{*5} | | MYCOM 125A ^{*5} | | JIS20K 150A | | JIS20K 250A | | JIS20K 350A | | ANSI#300 16" | | | |
| Gas outlet port | JIS20K 50A | | MYCOM 65A ^{*5} | | JIS20K 80A | | JIS20K 100A | | JIS20K 150A | | ANSI#300 8" | | | |

*1. Specify the refrigerant by adding a prefix to the model code (N = ammonia / F = fluorocarbons). *2. The model 1610SLC-52 includes an internal step-up gear.

*3. Value at 1450 rpm. *4. Value at 1750 rpm of the model 1610SLC-62. *5. Flanges with a designation starting with MYCOM are in-house products of MYCOM.

* The range of rotation speed varies by operating conditions. Please refer to the ranges of use stated in the operating instructions.

Outer dimensions

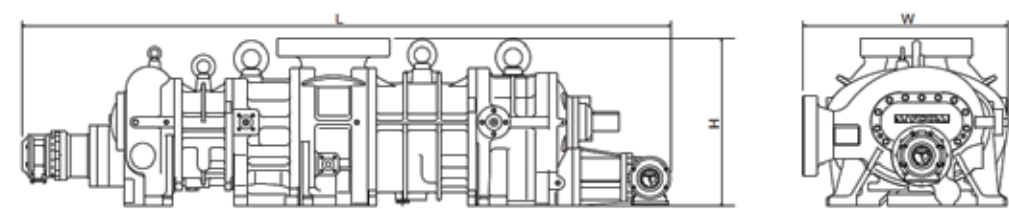

| Model | Weight | W | L | H |
|--------------------------|----------------|------------|-------------|------------|
| 1610SLC-52 ^{*1} | 1345lb/610kg | 25"/629mm | 55"/1400mm | 20"/511mm |
| 1612LSC | 1102lb/500kg | 20"/511mm | 52"/1321mm | 19"/493mm |
| 2016LSC | 2425lb/1100kg | 26"/657mm | 67"/1691mm | 20"/513mm |
| 2520LSC | 4519lb/2050kg | 31"/785mm | 98"/2487mm | 25"/640mm |
| 3225LSC | 7297lb/3310kg | 37"/945mm | 107"/2715mm | 33"/832mm |
| 4032LSC | 20613lb/9350kg | 46"/1181mm | 107"/2730mm | 51"/1305mm |

*1. Dimensions of the model 1610SLC-52 include an internal step-up gear.

* The outer dimension drawings illustrate the model 2520LSC. * Please consult us for further details.

i-SERIES

Screw Compressor [Single Stage] Open Type



Facilitates Design of Packaged Systems

Featuring a built-in suction strainer and check valve, the i-series screw compressor supports flange motors and facilitates the design of packaged systems.

New Design Eliminates the Need for an Oil Pump

The newly adopted ball bearings enable the i-series screw compressor to deliver high performance without a need of an oil pump.

Space Saving Design

Using a flange motor, the small-footprint compressor can be installed in a confined space.



Easily Maintainable

Designed to facilitate the replacement of consumables.

Specifications

| Item | | Model | i125 | | i160 | | |
|--------------------------|---------|--------------------------|-----------|-------|-------------|-----------|-----|
| | | | S | L | S | M | L |
| Refrigerant | | Ammonia / HFC | | | | | |
| Theoretical displacement | 2950rpm | CFM | 116 | 174 | 244 | 305 | 366 |
| | 3550rpm | CFM | 139 | 210 | 294 | 367 | 441 |
| Theoretical displacement | 2950rpm | m ³ /h | 197 | 296 | 415 | 519 | 622 |
| | 3550rpm | m ³ /h | 237 | 356 | 499 | 624 | 749 |
| Minimum rotation speed | rpm | 1450 ^{*1} | | | | | |
| Maximum rotation speed | rpm | 4500 | 3550 | 4500 | 3550 | 3550 | |
| Rotation direction | | CW as viewed from motor | | | | | |
| Capacity control | % | 50/75/ 100 | | | | | |
| Gas inlet port | | MYCOM 100A ^{*2} | | | ANSI#300 5" | | |
| Gas outlet port | | MYCOM 65CD ^{*2} | | | ANSI#300 3" | | |
| Flange motor connection | | NEMA | 3**C/40*C | | | 3**D/4**D | |
| | | IEC | FF400 | FF500 | FF500/FF600 | | |

* 1. The range of rotation speed varies by operating conditions. Please refer to the ranges of use stated in the operating instructions.

* 2. Flanges with a designation starting with MYCOM are in-house products of MYCOM.

Performance charts

| Refrigerant | | Ammonia | | | | R404A | | | | R134a | |
|----------------|-----------------------|---|---------|--|---------|---|---------|--|---------|--|---------|
| | | -40/+35°C • -40/+95°F | | -10/+35°C • +14/+95°F | | -40/+35°C • -40/+95°F | | 0/+40°C • +32/+104°F | | +2/+42°C • +36/+108°F | |
| Model | Temperature condition | Liquid Subcooling: 5°C/ 9°F Suction Superheat: 0°C/0°F Rotation speed: 2950rpm Economizer-type | | Liquid Subcooling: 5°C/ 9°F Suction Superheat: 0°C/0°F Rotation speed: 2950rpm | | Liquid Subcooling: 5°C/ 9°F Suction Superheat: 25°C/45°F Rotation speed: 2950rpm Economizer-type | | Liquid Subcooling: 5°C/ 9°F Suction Superheat: 25°C/45°F Rotation speed: 2950rpm | | Liquid Subcooling: 5°C/ 9°F Suction Superheat: 25°C/45°F Rotation speed: 2950rpm | |
| | i125S | Cooling Capacity | 9.6RT | 33.9kW | 35.8RT | 125.9kW | 11.5RT | 40.6kW | 43.9RT | 154.5kW | 28.7RT |
| Absorbed Power | | 35.0HP | 26.1kW | 47.3HP | 35.3kW | 46.1HP | 34.4kW | 63.0HP | 47.0kW | 35.7HP | 26.6kW |
| i125L | Cooling Capacity | 14.5RT | 51.0kW | 53.5RT | 188.1kW | 17.0RT | 59.9kW | 65.5RT | 230.4kW | 43.6RT | 153.3kW |
| | Absorbed Power | 51.1HP | 38.1kW | 69.1HP | 51.5kW | 66.9HP | 49.9kW | 91.9HP | 68.5kW | 53.5HP | 39.9kW |
| i160S | Cooling Capacity | 21.4RT | 75.2kW | 77.6RT | 272.9kW | 25.3RT | 89.0kW | 94.9RT | 333.9kW | 62.1RT | 218.6kW |
| | Absorbed Power | 73.9HP | 55.1kW | 99.6HP | 74.3kW | 97.2HP | 72.5kW | 132.5HP | 98.8kW | 75.0HP | 55.9kW |
| i160M | Cooling Capacity | 26.7RT | 94.0kW | 97.1RT | 341.6kW | 31.5RT | 110.9kW | 119.0RT | 418.5kW | 78.4RT | 275.6kW |
| | Absorbed Power | 89.2HP | 66.5kW | 120.0HP | 89.5kW | 117.1HP | 87.3kW | 159.6HP | 119.0kW | 92.0HP | 68.6kW |
| i160L | Cooling Capacity | 32.0RT | 112.6kW | 116.4RT | 409.4kW | 37.9RT | 133.5kW | 142.8RT | 502.4kW | 94.6RT | 332.8kW |
| | Absorbed Power | 105.8HP | 78.9kW | 142.5HP | 106.3kW | 138.8HP | 103.5kW | 189.6HP | 141.4kW | 110.4HP | 82.3kW |

* Please consult us for further details.

Outer dimensions

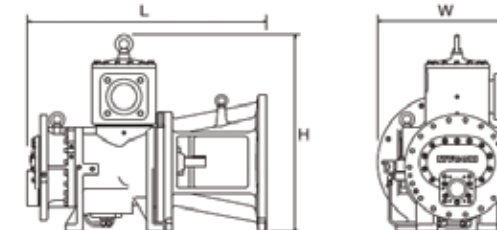

| Model | | Weight | W | L | H |
|-------|------------------|--------------|-----------|------------|-----------|
| i125S | w/o motor spacer | 728lb/330kg | 22"/555mm | 26"/656mm | 31"/799mm |
| | NEMA | 1080lb/490kg | 22"/550mm | 33"/831mm | 31"/799mm |
| | IEC FF400 | 970lb/440kg | 22"/555mm | 36"/906mm | 31"/799mm |
| i125L | w/o motor spacer | 772lb/350kg | 21"/535mm | 29"/726mm | 31"/799mm |
| | NEMA | 1124lb/510kg | 21"/530mm | 35"/901mm | 31"/799mm |
| | IEC FF500 | 1058lb/480kg | 22"/560mm | 38"/976mm | 31"/799mm |
| i160S | w/o motor spacer | 1146lb/520kg | 24"/619mm | 30"/773mm | 29"/745mm |
| | NEMA | 1477lb/670kg | 27"/694mm | 38"/974mm | 29"/745mm |
| | IEC FF500 | 1389lb/630kg | 25"/629mm | 40"/1023mm | 29"/745mm |
| | FF600 | 1455lb/660kg | 27"/682mm | 40"/1023mm | 29"/745mm |
| i160M | w/o motor spacer | 1235lb/560kg | 24"/619mm | 32"/818mm | 29"/745mm |
| | NEMA | 1565lb/710kg | 27"/694mm | 40"/1019mm | 29"/745mm |
| | IEC FF500 | 1477lb/670kg | 25"/629mm | 42"/1068mm | 29"/745mm |
| | FF600 | 1543lb/700kg | 27"/682mm | 42"/1068mm | 29"/745mm |
| i160L | w/o motor spacer | 1323lb/600kg | 24"/619mm | 34"/863mm | 29"/745mm |
| | NEMA | 1653lb/750kg | 27"/694mm | 42"/1064mm | 29"/745mm |
| | IEC FF500 | 1565lb/710kg | 25"/629mm | 44"/1113mm | 29"/745mm |
| | IEC FF600 | 1631lb/740kg | 27"/682mm | 44"/1113mm | 29"/745mm |

* The outer dimension drawings illustrate the model i125JL with an IEC FF500 motor spacer.

* Please consult us for further details.

UD-SERIES

Screw Compressor [Single Stage] Open Type



Supports Large-Capacity Range

A lineup of high-capacity compressors with a displacement of up to 9,182 CFM (15,600 m³/h), which is not available in the V-series.

Applications

Operates over a wide range of temperature and serves in industrial refrigerating and freezing applications. Also, workable as a booster compressor.

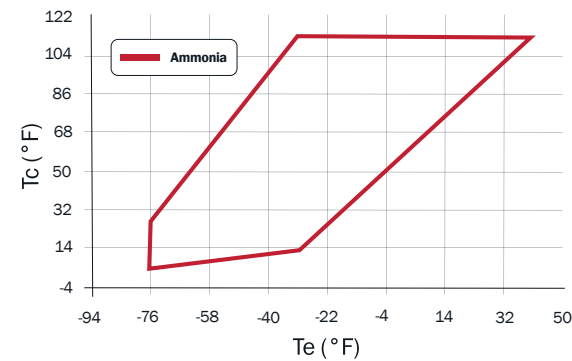

* The temperature range varies by model.

Longtime Seller

With a proven 4:6 rotor configuration, the UD-series offers optimal performance to customers.

Performance charts

| Refrigerant | Ammonia | | | | Propane | | R404A | | | | R134a | | | | |
|----------------|---|------------------|--|---------|--|----------|---|----------|--|----------|---|----------|---|----------|-----------------------|
| | Temperature condition | | -40/+35°C • -40/+95°F | | -40/-10°C • -40/+14°F | | -10/+35°C • +14/+95°F | | -10/+35°C • +14/+95°F | | -40/+35°C • -40/+95°F 400LL @ -40/+30°C 400LL @ -40/+86°F | | 0/+40°C • +32/+104°F 400LL @ 0/+30°C 400LL @ +32/+86°F | | +2/+42°C • +36/+108°F |
| Model | Liquid Subcooling: 5°C/ 9°F Suction Superheat: 0°C/0°F Rotation speed: 2950rpm Econimizer-type | | Liquid Subcooling: 5°C/ 9°F Suction Superheat: 0°C/0°F Rotation speed: 2950rpm | | Liquid Subcooling: 5°C/ 9°F Suction Superheat: 0°C/0°F Rotation speed: 2950rpm | | Liquid Subcooling: 5°C/ 9°F Suction Superheat: 10°C/0°F Rotation speed: 2950rpm | | Liquid Subcooling: 5°C/ 9°F Suction Superheat: 25°C/0°F Rotation speed: 2950rpm Econimizer-type | | Liquid Subcooling: 5°C/ 9°F Suction Superheat: 25°C/0°F Rotation speed: 2950rpm | | Liquid Subcooling: 5°C/ 9°F Suction Superheat: 25°C/0°F Rotation speed: 2950rpm | | |
| | 125SUD/G | Cooling Capacity | 9.6RT | 33.9kW | — | — | 35.8RT | 125.9kW | 28.9RT | 101.7kW | 11.5RT | 40.6kW | 43.9RT | 154.5kW | 28.7RT |
| Absorbed Power | | 33.9HP | 25.3kW | — | — | 47.3HP | 35.3kW | 43.6HP | 32.5kW | 46.1HP | 34.4kW | 63.0HP | 47.0kW | 35.7HP | 26.6kW |
| 125LUD/G | Cooling Capacity | 14.5RT | 51.0kW | — | — | 53.5RT | 188.1kW | 43.1RT | 151.7kW | 17.0RT | 59.9kW | 65.5RT | 230.4kW | 43.6RT | 153.3kW |
| | Absorbed Power | 49.5HP | 36.9kW | — | — | 69.1HP | 51.5kW | 63.4HP | 47.3kW | 66.9HP | 49.9kW | 91.9HP | 68.5kW | 53.5HP | 39.9kW |
| 400SUD | Cooling Capacity | 345.2RT | 1214.2kW | 391.9RT | 1378.3kW | 1230.9RT | 4329.6kW | 991.8RT | 3488.5kW | 396.0RT | 1392.9kW | 1503.3RT | 5287.6kW | 1010.4RT | 3553.9kW |
| | Absorbed Power | 1104.7HP | 823.8kW | 432.9HP | 322.8kW | 1541.3HP | 1149.4kW | 1417.4HP | 1057.0kW | 1481.3HP | 1104.6kW | 2050.4HP | 1529.0kW | 1205.6HP | 899.0kW |
| 400MUD | Cooling Capacity | 431.4RT | 1517.3kW | 492.3RT | 1731.5kW | 1546.3RT | 5438.9kW | 1245.9RT | 4382.3kW | 490.3RT | 1724.7kW | 1888.4RT | 6642.4kW | 1269.2RT | 4464.3kW |
| | Absorbed Power | 1383.9HP | 1032.0kW | 543.8HP | 405.5kW | 1936.3HP | 1443.9kW | 1780.6HP | 1327.8kW | 1850.7HP | 1380.1kW | 2575.7HP | 1920.7kW | 1514.4HP | 1129.3kW |
| 400LUD | Cooling Capacity | 512.6RT | 1803.0kW | 586.6RT | 2063.2kW | 1842.5RT | 6480.9kW | 1484.6RT | 5222.0kW | 580.2RT | 2040.7kW | 2250.2RT | 7915.0kW | 1512.4RT | 5319.9kW |
| | Absorbed Power | 1646.6HP | 1227.9kW | 648.0HP | 483.2kW | 2307.2HP | 1720.5kW | 2121.7HP | 1582.2kW | 2199.6HP | 1640.3kW | 3069.1HP | 2288.7kW | 1804.6HP | 1345.7kW |
| 400LLUD | Cooling Capacity | 601.1RT | 2114.3kW | 693.7RT | 2439.9kW | 2178.9RT | 7664.2kW | 1755.7RT | 6175.4kW | 716.3RT | 2519.6kW | 3088.6RT | 10864.0kW | 1793.1RT | 6307.1kW |
| | Absorbed Power | 1939.2HP | 1446.1kW | 766.2HP | 571.4kW | 2728.4HP | 2034.6kW | 2509.1HP | 1871.1kW | 2385.8HP | 1779.1kW | 2958.2HP | 2206.0kW | 2134.1HP | 1591.4kW |
| 400XLUD | Cooling Capacity | — | — | 778.8RT | 2739.5kW | — | — | — | — | — | — | — | — | — | — |
| | Absorbed Power | — | — | 860.4HP | 641.6kW | — | — | — | — | — | — | — | — | — | — |

* The machine cannot be used under certain conditions. Please consult us for further details.

Specifications

| Item | Model (N/P/F) ^{*1 *2} | | 125 | | 400 | | | | |
|--------------------------|-------------------------------------|--------------------|-----|--------------------|------|------|-------|-------|-------|
| | SUD | LUD | SUD | LUD | MUD | LUD | LLUD | XLUD | |
| Refrigerant | Ammonia / Propane, propylene / HFCs | | | | | | | | |
| Theoretical displacement | 2950rpm | CFM | 116 | 174 | 3814 | 4791 | 5709 | 6769 | 7593 |
| | 3550rpm | CFM | 139 | 210 | 4591 | 5768 | 6886 | 8122 | 9182 |
| Theoretical displacement | 2950rpm | m ³ /h | 197 | 295 | 6480 | 8140 | 9700 | 11500 | 12900 |
| | 3550rpm | m ³ /h | 237 | 356 | 7800 | 9800 | 11700 | 13800 | 15600 |
| Minimum rotation speed | rpm | 1450 ^{*3} | | 1450 ^{*3} | | | | | |
| Maximum rotation speed | rpm | 4500 ^{*3} | | 3600 ^{*3} | | | | | |
| Rotation direction | CCW as viewed from motor | | | | | | | | |
| Capacity control | % | 30-100 | | | | | | | |
| Gas inlet port | MYCOM 100A ^{*4} | | | ANSI#300 16" | | | | | |
| Gas outlet port | MYCOM 65CD ^{*4} | | | ANSI#300 12" | | | | | |

* 1. Specify the refrigerant by adding a prefix to the model code (N = ammonia / P = propane, propylene / F = fluorocarbons).

* 2. Please contact us separately for models with a designation ending with G (downward discharge).

* 3. The range of rotation speed varies by operating conditions. Please refer to the ranges of use stated in the operating instructions.

* 4. Flanges with a designation starting with MYCOM are in-house products of MYCOM.

Outer dimensions

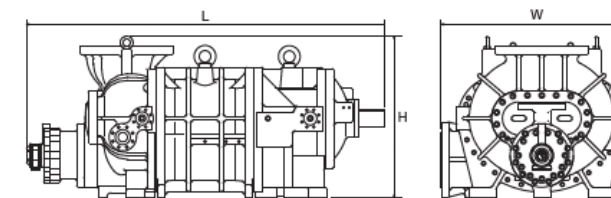

| Model | Weight | W | L | H |
|--------|-------------|-----------|-----------|-----------|
| 125SUD | 441lb/200kg | 16"/404mm | 33"/846mm | 15"/386mm |
| 125LUD | 485lb/220kg | 16"/404mm | 36"/916mm | 15"/386mm |

| Model | Weight | W | L | H |
|---------|----------------|------------|-------------|------------|
| 400SUD | 11707lb/5310kg | 51"/1290mm | 83"/2109mm | 44"/1120mm |
| 400MUD | 13580lb/6160kg | 51"/1290mm | 90"/2275mm | 44"/1120mm |
| 400LUD | 15454lb/7010kg | 51"/1290mm | 98"/2491mm | 44"/1120mm |
| 400LLUD | 17218lb/7810kg | 51"/1290mm | 103"/2613mm | 44"/1120mm |
| 400XLUD | 19577lb/8880kg | 51"/1290mm | 107"/2716mm | 44"/1120mm |

* The outer dimension drawings illustrate the model 400LUD. * Please contact us separately for models with a designation ending with G (downward discharge).

* Please consult us for further details.

MHS-SERIES

Screw Compressor [Two Stage] Open Type



High Efficiency

The water-cooled semi-hermetic motor, as well as Mayekawa's unique rotor design featuring different diameters, enables high efficiency.

Allows Compact Packaging

The semi-hermetic motor, as well as the integral oil separator, enables compact packaging of the MHS series.

Reduced Noise and Vibration

New Design Eliminates the Need for an Oil Pump

The newly adopted ball bearings eliminate the need for an oil pump and enable the delivery of high performance.

Performance charts

| Refrigerant | | R404A | |
|-----------------------|------------------|--|--------|
| Temperature condition | | -40/+35°C • -40/+95°F | |
| Model | | Liquid Subcooling: 5°C/ 9°F Suction Superheat: 20°C/36°F Rotation speed: 2950rpm | |
| 22H1290SSC | Cooling Capacity | 9.3RT | 32.6kW |
| | Absorbed Power | 30.8HP | 23.0kW |
| 37H1410SSC | Cooling Capacity | 15.2RT | 53.5kW |
| | Absorbed Power | 47.5HP | 35.4kW |

* The machine cannot be used under certain conditions. Please consult us for further details.

Specifications

| Item | Model | 22H1290SSC | | 27H1290SSC | | 37H140SSC | | |
|--------------------------|---------|-------------------|------------|------------|------------|-------------------|------------|------|
| | | Low Stage | High Stage | Low Stage | High Stage | Low Stage | High Stage | |
| Refrigerant | | R404A/R507A | | | | | | |
| Theoretical displacement | 2950rpm | CFM | 85 | 32 | 85 | 32 | 131 | 49 |
| | 3550rpm | CFM | 103 | 39 | 103 | 39 | 158 | 59 |
| Theoretical displacement | 2950rpm | m³/h | 145 | 54.4 | 145 | 54.4 | 222 | 83.9 |
| | 3550rpm | m³/h | 175 | 65.6 | 175 | 65.6 | 268 | 101 |
| Minimum rotation speed | rpm | 1500 | | | | | | |
| Maximum rotation speed | rpm | 4200 | | | | | | |
| Capacity control | % | 50/100 | | | | | | |
| Gas inlet port | | 50A ^{*1} | | | | 65A ^{*1} | | |
| Gas outlet port | | 25A ^{*1} | | | | 32A ^{*1} | | |
| Semi-hermetic moto | kW | 22 | | 27 | | 37 | | |

* 1. Mayekawa's uniquely designed flange is used.

* 2. The range of rotation speed varies by operating conditions. Please refer to the ranges of use stated in the operating instructions.

Outer dimensions

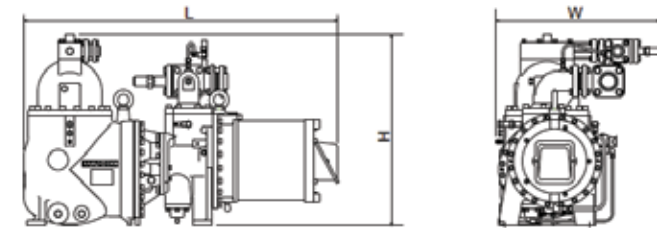

| Model | Weight | W | L | H |
|------------|--------------|-----------|------------|-----------|
| 22H1290SSC | 1146lb/520kg | 27"/693mm | 52"/1312mm | 31"/797mm |
| 27H1290SSC | 1235lb/560kg | 27"/693mm | 53"/1352mm | 31"/797mm |
| 37H1410SSC | 1786lb/810kg | 30"/765mm | 58"/1472mm | 35"/887mm |

* The outer dimension drawings illustrate the model 37H1410SSC. * Please consult us for further details.

MYPRO TOUCH+ CONTROL PANEL



Screw Package Panel

MYPRO TOUCH+

Control panel for MYCOM Screw Compressor Packages

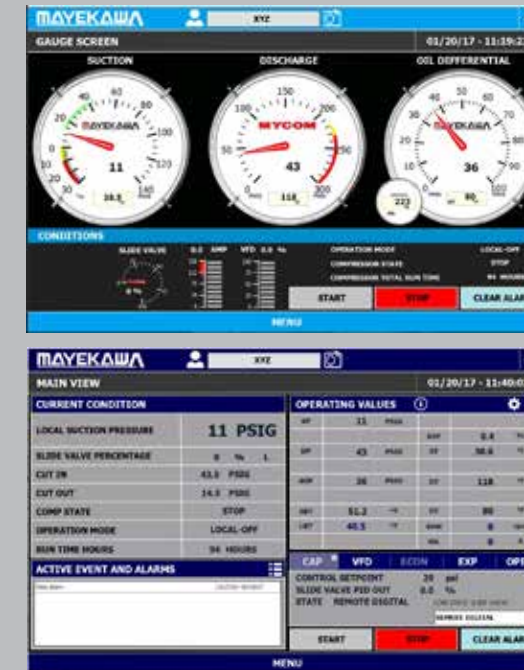

The MYPRO TOUCH+ has control capabilities for screw compressor packages, chillers and basic system equipment such as compressor vibration sensors, motor temperatures and vessel levels.

Standard Features

- » 13.3" widescreen touch
- » APP style menu interface
- » Ethernet connectivity
- » SD card storage
- » Onboard
 - Operating instruction manual
 - Data sheets
 - Drawings
 - Instructional videos
- » Communications
 - Legacy Modbus RTU
 - Modbus TCP/IP
 - Allen Bradley Logix drivers
 - VNC technology for remote desktop
- » Password protection
- » Real time and historical trending
- » Email alarm notification

Specifications

| | | | |
|----------------|--|--|---|
| Screen Size | 13.3" Diagonal | Display Resolution | 1280 x 800 |
| Communication | RS-485 Ethernet (2) USB (2) | Control Voltage | 100V~120V / 220V~240V |
| | | Electrical Frequency | 50 / 60Hz |
| | | Ambient Temperature | 32°F~122°F (0°C~50°C) 85% R.H. |
| Memory Storage | SD Card (32GB max.) | Dimensions | H30" x W24" x D10" H762mm x W610mm x D254mm |
| Analog Input | | Digital I/O | |
| Current | 4-20 mA DC | Digital Input | Do NOT apply voltage to connection. Board supplies internal 12 VDC Max. 25 mA |
| Voltage | 1-5 VDC | | |
| Potentiometer | 1-1000 ohm; Qty. 2 | | |
| Analog Output | | Digital Output- Solid State Relay Ratings | 100-240 VAC, 2A Leakage Current <1.5 mA |
| QTY | 4 | | |
| Current Signal | 4-20 mA DC Load resistance <500 ohm | | |

RECIPROCATING COMPRESSORS



M-series
K-series
HS-series
HK-series
WBHE-series
WA-series
L-series

For 95 years since Mayekawa started manufacturing piston compressors, Mayekawa has listened to the customers' demand to advance its technology to develop MYCOM Reciprocating Compressors. Mayekawa has a full-lineup of compressors that cover a wide range of applications with various pressures and volumes.

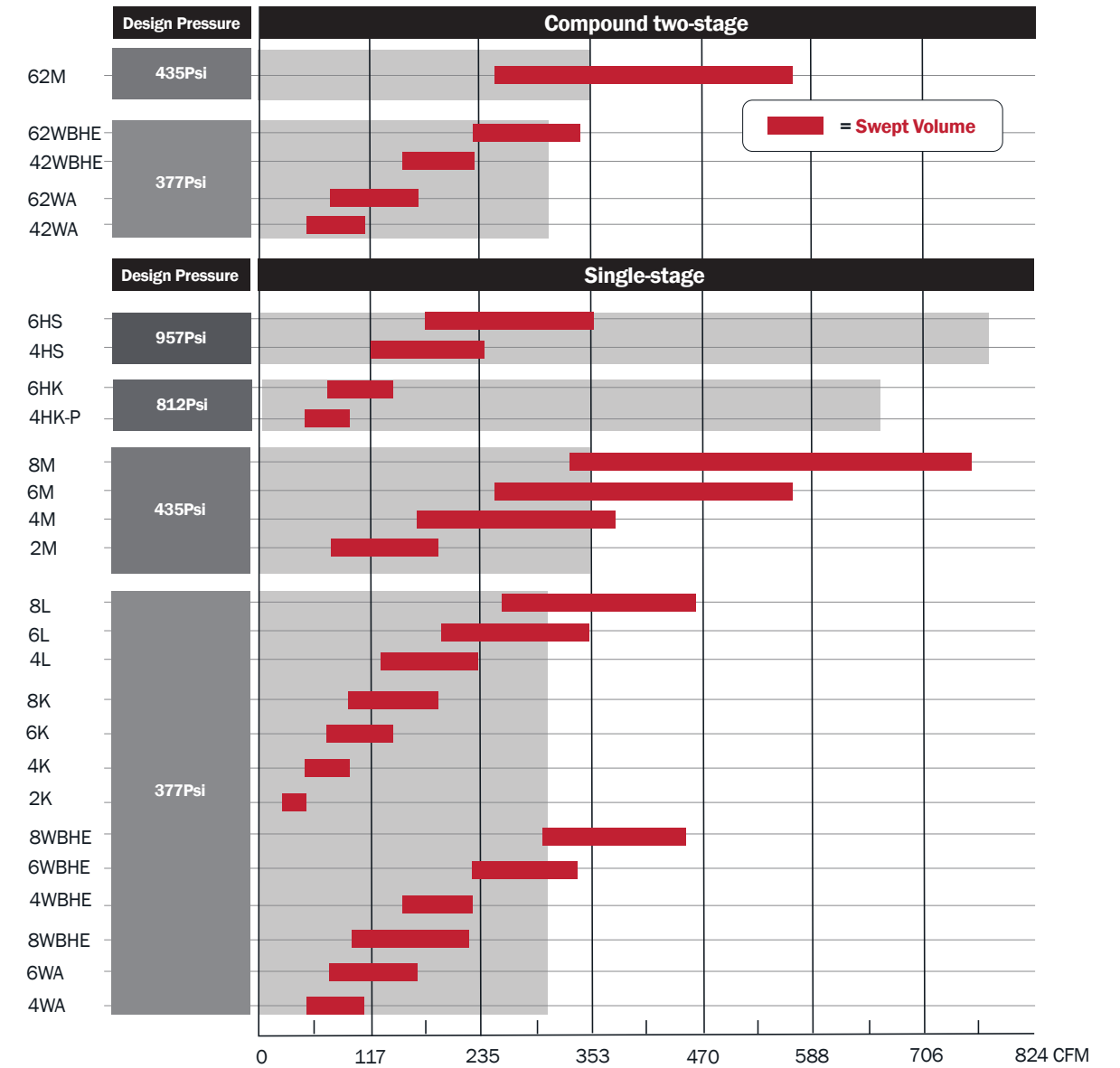

Compound two-stage
62M-series: 660-1500rpm / 42/62WBHE-series: 800-1200rpm / 42/62WA-series: 650-1450rpm
Single-stage
4/6HS-series: 750-1500rpm / 4/6HK-series: 900-1800rpm / 2-8M-series: 660-1500rpm / 4-8L-series: 970-1750rpm / 2-8K-series: 900-1800rpm / 4-8WBHE-series: 800-1200rpm / 4-8WA-series: 650-1450rpm

M-SERIES

Reciprocating Compressor [Single Stage] Open Type & [Two Stage] Open Type



High Performance Derived from New Design

This newly designed compressor minimizes internal heating of the intake gas resulting in the highest level of performance in our product portfolio.

Much Improved Overhaul Intervals

The M-series incorporates a new valve structure with improved durability and dramatically extended overhaul intervals of 16,000 hours.

Supports a Wide Range of Pressure Conditions

The components are designed for high pressure applications and a wide range of operating conditions. The M-series can be used in demanding applications such as high pressure systems and heat pumps.

Easy Maintenance

Hydraulic lines for capacity control are incorporated into the casing design, allowing simplified package designs as well as easy replacement of consumable components.

Multiple Applications

Multiple configurations are available in drive type (direct drive/belt drive) and refrigerant compatibility (Ammonia, Propane and Fluorocarbon refrigerants).

Performance charts

Ammonia

Condensing temp: 104°F Rotation speed: 970rpm
Suction superheat: 0°F Liquid Subcooling: 9°F

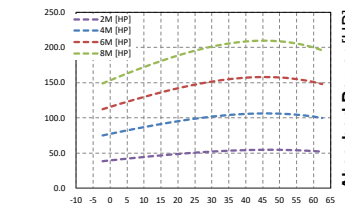
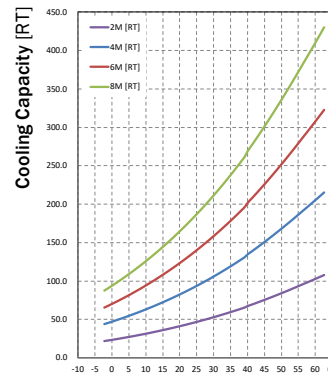

Evaporating Temp. [°F]

Propane

Condensing temp: 104°F Rotation speed: 970rpm
Suction superheat: 18°F Liquid Subcooling: 9°F

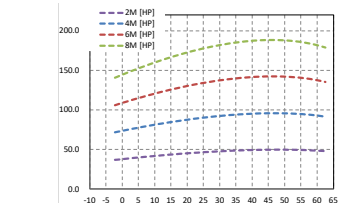
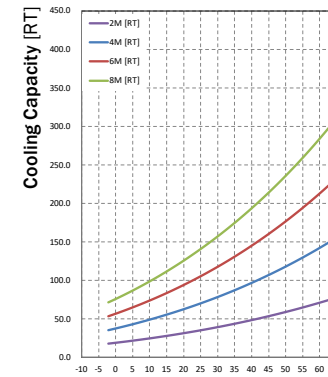

Evaporating Temp. [°F]

R404A

Condensing temp: 104°F Rotation speed: 970rpm
Suction superheat: 36°F Liquid Subcooling: 9°F

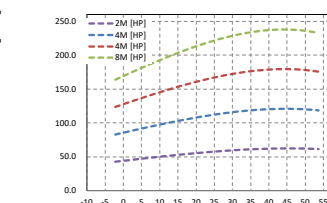
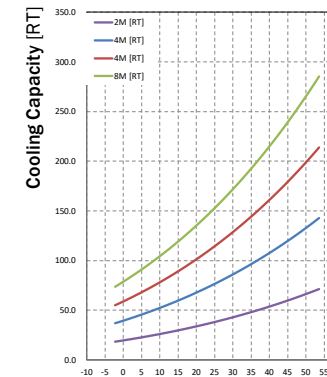

Evaporating Temp. [°F]

R134a

Condensing temp: 104°F Rotation speed: 970rpm
Suction superheat: 36°F Liquid Subcooling: 9°F

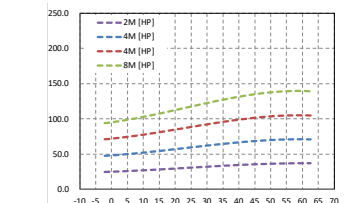
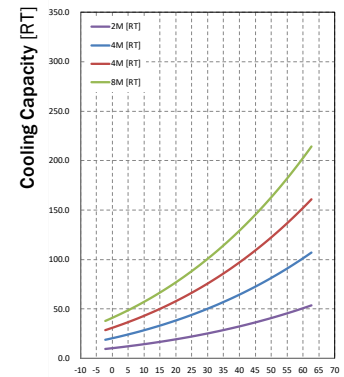

Evaporating Temp. [°F]

Specifications

*Some optional items are included in this photo.

| Model ^{*1} (N/P/F) | | 2M | 4M | 6M | 8M | 62M |
|-----------------------------|-------------------|---|--------|------------------------|--------------|---|
| Item | | | | | | |
| Refrigerant | | Ammonia / Propane, Propylene / HFCs (R134a, R404A, R507A) | | | | Ammonia / HFCs (R404A, R507A) |
| Compressor Type | | Reciprocating, Open Type | | | | |
| Number of Cylinders | | 2 | 4 | 6 | 8 | Low Stage: 6 High Stage: 2 |
| Bore | | 5.8" / 146mm | | | | |
| Stroke | | 4.2" / 106mm | | | | |
| Displacement ^{*2} | CFM | 122 | 243 | 365 | 486 | Low Stage: 365 High Stage: 122 |
| Displacement ^{*2} | m ³ /h | 207 | 413 | 620 | 826 | Low Stage: 620 High Stage: 207 |
| Rotation Speed | rpm | 600-1500 ^{*3} | | 660-1500 ^{*3} | | |
| Drive Method | | Direct Drive / V-belt | | | | Direct Drive / Overhang moto / V-belt |
| Capacity Control | % | 100/50 | 100/50 | 100/66/33 | 100/75/50/25 | 100/66/33 |

*1. Specify the refrigerant by adding a prefix to the type code (N = Ammonia / P = Propane / F = Fluorocarbons).

*2. Displacement at 970 rpm

*3. The range of rotation speed varies by operating conditions. Please refer to the ranges of use stated in the operating instructions.

Outer dimensions

*Please consult us for compound performance charts or further details.

[Air cooled type (Propane, HFCs)]

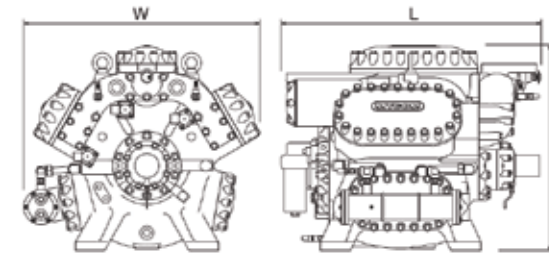

| Model (P/F) | Weight | W | L | H |
|-------------|---------------|------------|------------|-----------|
| 2M | 1489lb/675kg | 28"/715mm | 42"/1070mm | 35"/890mm |
| 4M | 2381lb/1080kg | 39"/995mm | 45"/1150mm | 35"/890mm |
| 6M | 2888lb/1310kg | 42"/1065mm | 46"/1165mm | 36"/920mm |
| 8M | 3384lb/1535kg | 43"/1085mm | 47"/1205mm | 36"/910mm |
| 62M | 3726lb/1690kg | 43"/1085mm | 47"/1205mm | 37"/930mm |

* The outer dimension drawings illustrate the 6-cylinder model.

* The stop valve, companion flange, flywheel, V-pulley, and safety valve are not included. * The oil cooler is included.

[Water cooled type (Ammonia)]

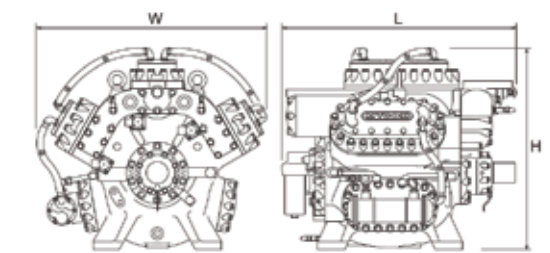

| Model (N) | Weight | W | L | H |
|-----------|---------------|------------|------------|------------|
| 2M | 1510lb/685kg | 28"/715mm | 42"/1070mm | 38"/960mm |
| 4M | 2425lb/1100kg | 40"/1020mm | 45"/1150mm | 40"/1025mm |
| 6M | 2954lb/1340kg | 45"/1150mm | 46"/1165mm | 39"/1000mm |
| 8M | 3472lb/1575kg | 45"/1150mm | 47"/1205mm | 40"/1020mm |
| 62M | 3814lb/1730kg | 47"/1195mm | 47"/1205mm | 40"/1020mm |

K-SERIES

Reciprocating Compressor [Single Stage] Open Type



Multiple Applications

Multiple configurations are available in drive type (direct/belt) and refrigerant compatibility (Ammonia, propane and fluorocarbon refrigerants). A compressor suited for many different refrigeration applications:

[Usable Refrigerants]

Natural Refrigerants

Ammonia
Propane
Propylene

Fluorocarbon Refrigerants

R134a
R407C
R407F
R404A
R507A

Supports a Wide Range of Pressure Conditions

The components are designed for high pressure applications and a wide range of operating conditions. The K-series can be used in demanding applications such as high pressure systems and heat pumps.

Variable Load Capability

A wide rotational speed range from 800 to 1800rpm provides a powerful output capacity.

Simplified Package Design

Hydraulic lines for capacity control are incorporated into the casing design, allowing for simplified package designs and easy maintenance.

Performance charts

Ammonia

Condensing temp: 104°F Rotation speed: 970rpm
Suction superheat: 0°F Liquid Subcooling: 9°F

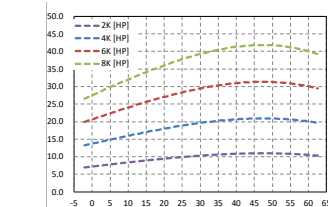
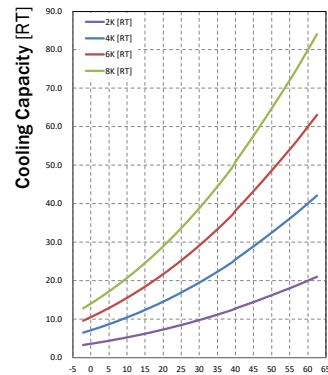

Propane

Condensing temp: 104°F Rotation speed: 970rpm
Suction superheat: 18°F Liquid Subcooling: 9°F

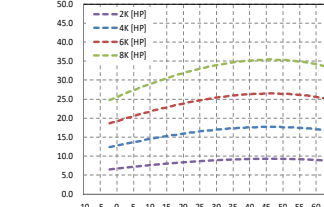
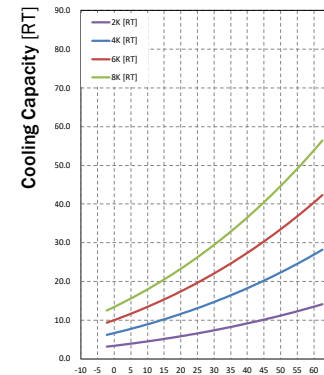

R404A

Condensing temp: 104°F Rotation speed: 970rpm
Suction superheat: 36°F Liquid Subcooling: 9°F

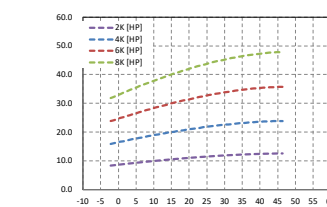
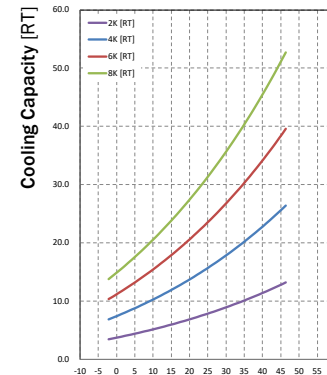

R134a

Condensing temp: 104°F Rotation speed: 970rpm
Suction superheat: 36°F Liquid Subcooling: 9°F

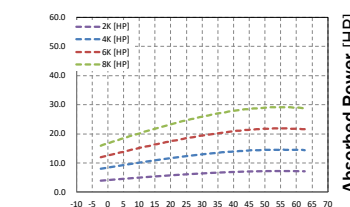
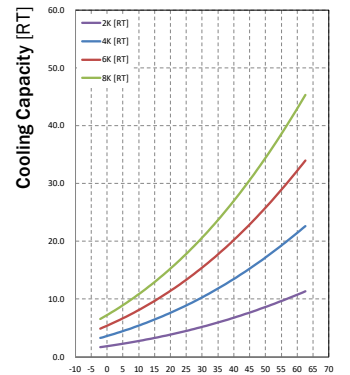

Specifications

*Some optional items are included in this photo.

| Model*1 (N/P/F) | | 2K | 4K | 6K | 8K |
|---------------------|---------------------------|---|--------------|-----------------|--------------|
| Item | | | | | |
| Refrigerant | | Ammonia / Propane, Propylene / HFCs (R134a, R407C, R407F, R404A, R507A) | | | |
| Compressor Type | | Reciprocating, Open Type | | | |
| Number of Cylinders | | 2 | 4 | 6 | 8 |
| Bore | | 3.4" / 85mm | | | |
| Stroke | | 2.56" / 65mm | | | |
| Displacement*2 | CFM | 25.2 | 50.6 | 75.9 | 101.2 |
| Displacement*2 | m ³ /h | 42.9 | 85.9 | 129 | 172 |
| Rotation Speed | rpm | 800-1800*3 | | | |
| Drive Method | | Direct Drive / V-belt | | | |
| Capacity Control | Ammonia | 100/50 | 100/50 | 100/66/33 | 100/75/50/25 |
| | Propane, Propylene / HFCs | 100/50 | 100/75/50/25 | 100/83/66/50/33 | 100/75/50/25 |

*1. Specify the refrigerant by adding a prefix to the type code (N = Ammonia / P = Propane / F = Fluorocarbons).

*2. Displacement at 970 rpm

*3. The range of rotation speed varies by operating conditions. Please refer to the ranges of use stated in the operating instructions.

Outer dimensions

*Please consult us for compound performance charts or further details.

[Air cooled type (Propane, HFCs)]

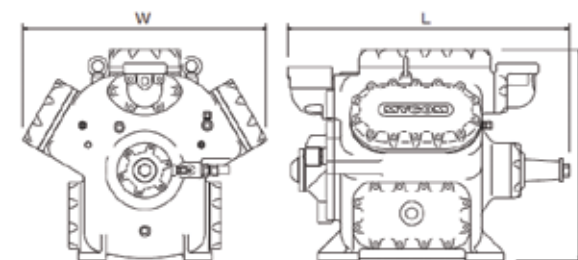

| Model (P/F) | Weight | W | L | H |
|-------------|-------------|-----------|-----------|-----------|
| 2K | 397lb/180kg | 18"/445mm | 26"/665mm | 21"/540mm |
| 4K | 606lb/275kg | 22"/565mm | 28"/715mm | 21"/530mm |
| 6K | 705lb/320kg | 25"/640mm | 29"/725mm | 22"/560mm |
| 8K | 838lb/380kg | 25"/640mm | 29"/740mm | 22"/570mm |

[Water cooled type (Ammonia)]

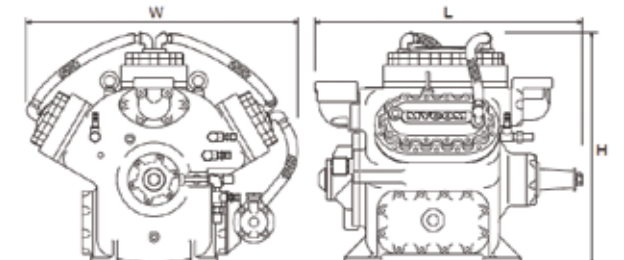

| Model (N) | Weight | W | L | H |
|-----------|-------------|-----------|-----------|-----------|
| 2K | 408lb/185kg | 20"/510mm | 26"/665mm | 25"/625mm |
| 4K | 628lb/285kg | 25"/645mm | 28"/715mm | 22"/570mm |
| 6K | 750lb/340kg | 29"/740mm | 29"/725mm | 25"/625mm |
| 8K | 893lb/405kg | 30"/765mm | 29"/740mm | 26"/660mm |

* The outer dimension drawings illustrate the 6-cylinder model.

* The stop valve, companion flange, flywheel, V-pulley, and safety valve are not included. * The oil cooler is included only for the water cooled type.

HK-SERIES

Reciprocating Compressor [Single Stage] Open Type



A Compressor Compatible with Ammonia Heat Pump Systems

Achieved condensing temperature at 85°C to operate with ammonia heat pump systems. This series can also be used for systems utilizing exhaust and waste heat.

50bar High Pressure Design

From CO₂ cascades to ammonia heat pumps, these compressors are designed for a wide temperature range. This series can also be used for CO₂ hot gas defrost systems.

High Reliability

Since its production launch in 2004, the HK series has become the trusted model for many applications.

Performance charts

Ammonia

Condensing temp: 185°F Rotation speed: 970rpm
Suction superheat: 0°F Liquid subcooling: 7°F

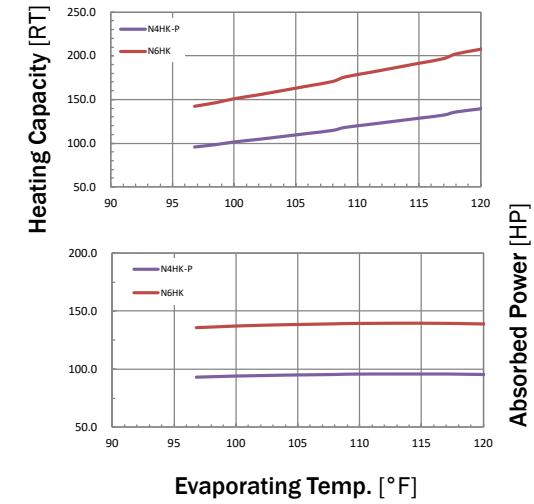

CO₂

Condensing temp: 14°F Rotation speed: 970rpm
Suction superheat: 0°F Liquid subcooling: 0°F

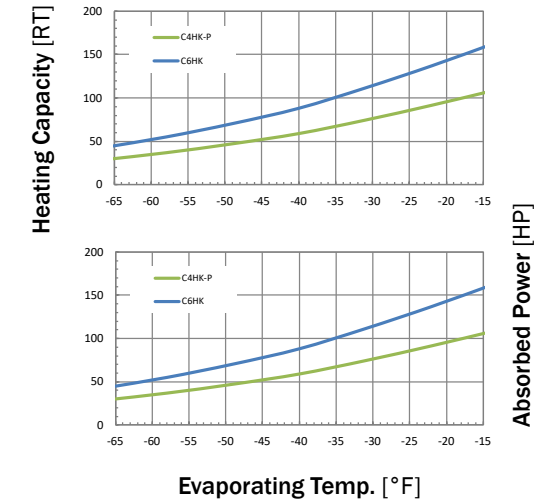

Specifications

*Some optional items are included in this photo.

| Model ^{*1} (N/C) | | 4HK-P | 6HK |
|----------------------------|-------------------|---------------------------|-----------|
| Item | | | |
| Refrigerant | | Ammonia / CO ₂ | |
| Compressor Type | | Reciprocating, Open Type | |
| Number of Cylinders | | 4 | 6 |
| Bore | | 3.4" / 85mm | |
| Stroke | | 2.6" / 65mm | |
| Displacement ^{*2} | CFM | 75.3 | 113.6 |
| Displacement ^{*2} | m ³ /h | 128 | 193 |
| Rotation Speed | rpm | 900-1800 ^{*3} | |
| Drive Method | | Direct Drive | |
| Capacity Control | % | 100/50 | 100/66/33 |

*1. Specify the refrigerant by adding a prefix to the type code (N = Ammonia / C = CO₂).

*2. Displacement at 1450 rpm

*3. The range of rotation speed varies by operating conditions. Please refer to the ranges of use stated in the operating instructions.

Outer dimensions

*Please consult us for further details.

[Air cooled type (CO₂)]

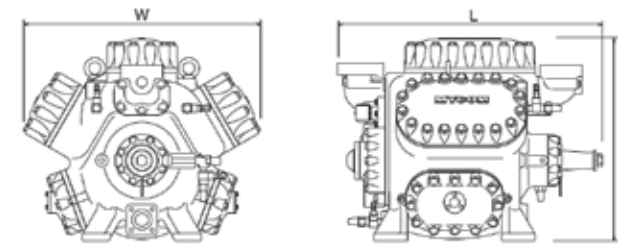

| Model (C) | Weight | W | L | H |
|-----------|-------------|-----------|-----------|-----------|
| 4HK-P | 772lb/350kg | 27"/680mm | 31"/785mm | 23"/585mm |
| 6HK | 772lb/350kg | 27"/680mm | 31"/785mm | 23"/585mm |

* The outer dimension drawings illustrate the 6-cylinder model.

* The stop valve, companion flange, flywheel, safety valve, and oil cooler are not included.

[Water cooled type (Ammonia)]

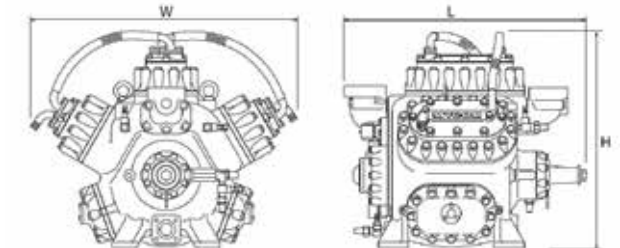

| Model (N) | Weight | W | L | H |
|-----------|-------------|-----------|-----------|-----------|
| 4HK-P | 794lb/360kg | 33"/840mm | 31"/785mm | 27"/685mm |
| 6HK | 794lb/360kg | 33"/840mm | 31"/785mm | 27"/685mm |

HS-SERIES

Reciprocating Compressor [Single Stage] Open Type



A Newly Designed Compressor Series Which Can Generate up to 194°F (90°C) Hot Water with Ammonia Heat Pump Systems

Oil consumption has been reduced through design review and achieved stable operation of ammonia heat pump systems. This series can also be used for systems utilizing exhaust and waste heat.

60bar High Pressure Design

Achieved higher pressure design compared with conventional high pressure compressors. From CO₂ cascades to ammonia heat pumps, these compressors can be utilized for a wide temperature range. This series can also be used for CO₂ hot gas defrost systems.

Achieved High Capacity

The HS series has a capacity at about 3 times as high compared with conventional high pressure compressors. This flexibly contributes to the application with large scale systems.

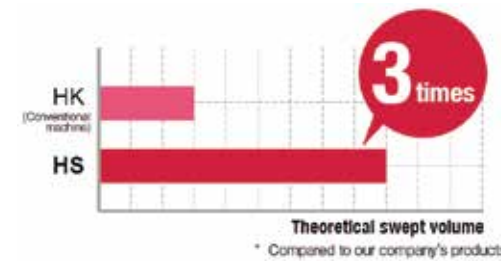

Performance charts

Ammonia

Condensing temp: 185°F Rotation speed: 970rpm
Suction superheat: 0°F Liquid subcooling: 7°F

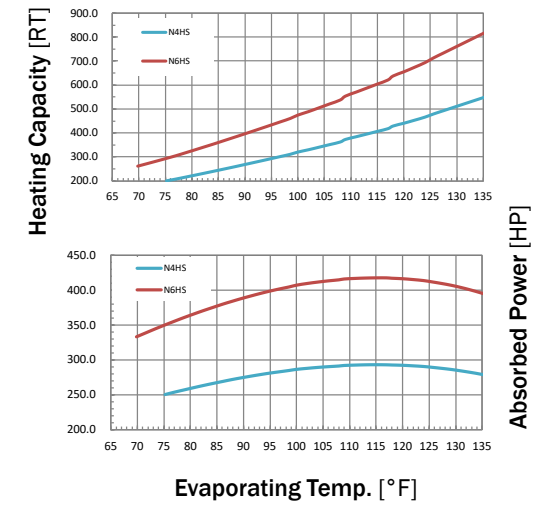

CO₂

Condensing temp: 14°F Rotation speed: 970rpm
Suction superheat: 0°F Liquid subcooling: 0°F

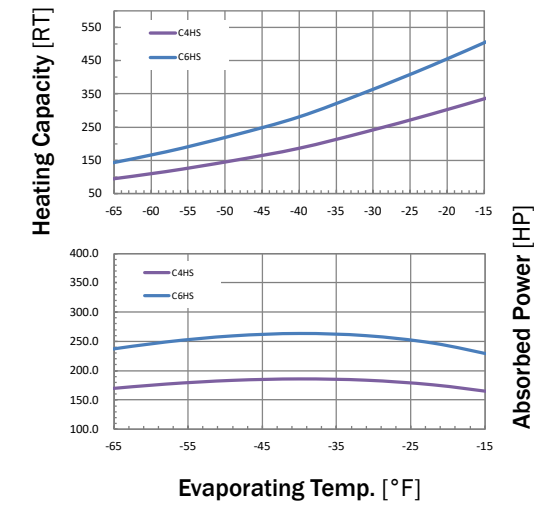

Specifications

*Some optional items are included in this photo.

| Item | Model ^{*1} (N/C) | 4HS | 6HS |
|----------------------------|---------------------------|---------------------------|-----------------|
| Refrigerant | | Ammonia / CO ₂ | |
| Compressor Type | | Reciprocating, Open Type | |
| Number of Cylinders | | 4 | 6 |
| Bore | | 5.1"/130mm | |
| Stroke | | 3.3"/84mm | |
| Displacement ^{*2} | CFM | 228.4 | 342.6 |
| Displacement ^{*2} | m ³ /h | 388 | 582 |
| Rotation Speed | rpm | 750-1500 ^{*3} | |
| Drive Method | | Direct Drive | |
| Capacity Control | % | 100/75/50/25 | 100/83/66/50/33 |

*1. Specify the refrigerant by adding a prefix to the type code (N = Ammonia / C = CO₂).

*2. Displacement at 1450 rpm

*3. The range of rotation speed varies by operating conditions. Please refer to the ranges of use stated in the operating instructions.

Outer dimensions

*Please consult us for further details.

[Air cooled type (CO₂)]

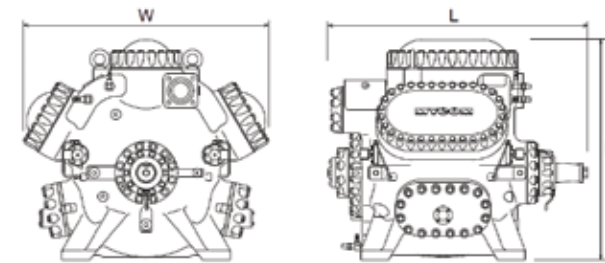

| Model (C) | Weight | W | L | H |
|-----------|---------------|------------|------------|------------|
| 4HS | 3527lb/1600kg | 40"/1020mm | 44"/1115mm | 39"/1000mm |
| 6HS | 3968lb/1800kg | 45"/1135mm | 46"/1165mm | 40"/1020mm |

* The outer dimension drawings illustrate the 6-cylinder model.

* The stop valve, companion flange, flywheel, safety valve, and oil cooler are not included.

[Water cooled type (Ammonia)]

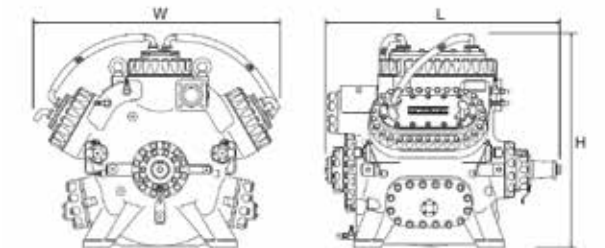

| Model (N) | Weight | W | L | H |
|-----------|---------------|------------|------------|------------|
| 4HS | 3638lb/1650kg | 43"/1100mm | 44"/1115mm | 43"/1100mm |
| 6HS | 4079lb/1850kg | 50"/1260mm | 46"/1165mm | 43"/1095mm |

WBHE-SERIES

Reciprocating Compressor [Single Stage] Open Type & [Two Stage] Open Type



*Some optional items are included in this photo.

New Design with Enhanced Performance

Redesigned valve structure and reduced mechanical losses have achieved further improvements in performance compared to conventional models.

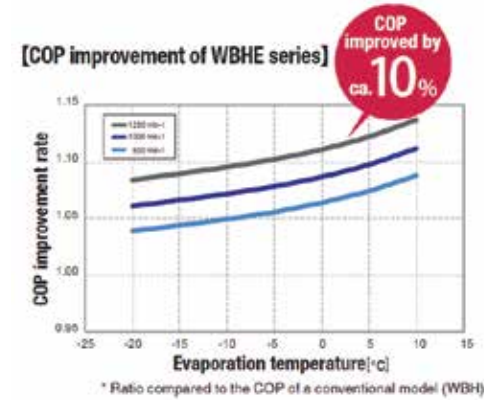

Applications

With a high-pressure design suitable for use in air-cooled condensing units for fluorocarbon refrigerants, the model operates over a wide range of temperature and serves in large-scale refrigerating and freezing applications.

[Usable Refrigerants]

Natural Refrigerants
Ammonia
Propane

Fluorocarbon Refrigerants
R134a
R404A
R507A
R23

Applications

A long-selling model with industry-leading reliability and track record, designed for tough applications subject to load fluctuation.

Specifications

| Model*1 (N/P/F) | | 4WBHE | 6WBHE | 8WBHE | 42WBHE | 62WBHE |
|---------------------|-------------------|---|---------------|------------------|--------------------------------------|--------------------------------------|
| Item | | | | | | |
| Refrigerant | | Ammonia / Propane / HFCs (R134a, R404A, R507A, R23*2) | | | Ammonia / HFCs (R404A, R507A) | |
| Compressor Type | | Reciprocating, Open Type | | | | |
| Number of Cylinders | | 4 | 6 | 8 | Low Stage: 4 High Stage: 2 | Low Stage: 6 High Stage: 2 |
| Bore | | 5.1"/130mm | | | | |
| Stroke | | 3.9"/100mm | | | | |
| Displacement*2 | CFM | 181.9 | 273.1 | 363.7 | Low Stage: 181.9 High Stage: 91.2 | Low Stage: 273.1 High Stage: 91.2 |
| Displacement*2 | m ³ /h | 309 | 464 | 618 | Low Stage: 309 High Stage: 155 | Low Stage: 464 High Stage: 155 |
| Rotation Speed | rpm | 800-1200*4 | | | | |
| Drive Method | | Direct Drive / V-belt | | | | |
| Capacity Control | % | 100/50 | 100/66/33/0*5 | 100/75/50/25/0*5 | 100/50 | 100/66/33 |

*1. Specify the refrigerant by adding a prefix to the type code (N = Ammonia / P = Propane / F = Fluorocarbons).

*2. If R23 is to be used as the refrigerant, the machine will come with special specifications. Please contact us for detailed information.

*3. Displacement at 970 rpm

*4. The range of rotation speed varies by operating conditions. Please refer to the ranges of use stated in the operating instructions.

*5. The capacity control value of 0% can be realized by an optional feature. Please contact us for detailed information.

Performance charts

Ammonia

Condensing temp: 104°F Rotation speed: 970rpm
Suction superheat: 0°F Liquid Subcooling: 9°F

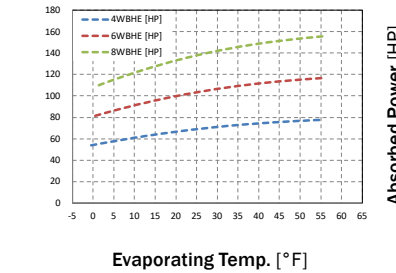
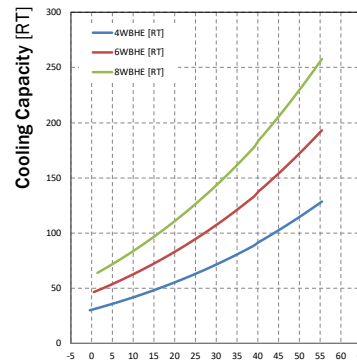

R404A

Condensing temp: 104°F Rotation speed: 970rpm
Suction superheat: 36°F Liquid Subcooling: 9°F

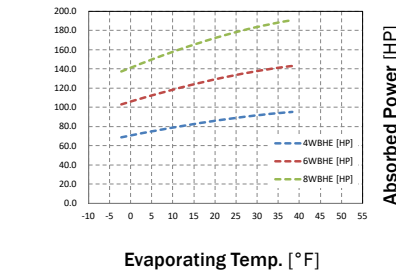
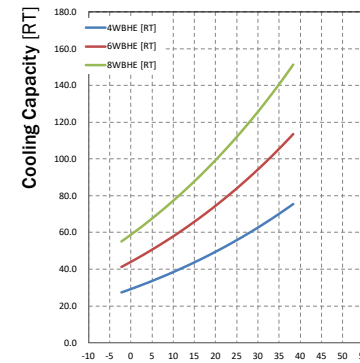

R134a

Condensing temp: 104°F Rotation speed: 970rpm
Suction superheat: 36°F Liquid Subcooling: 9°F

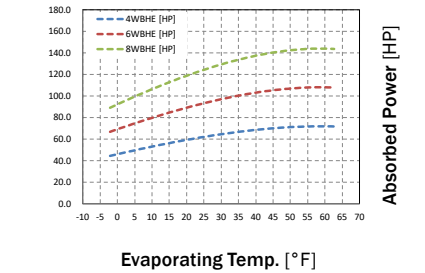
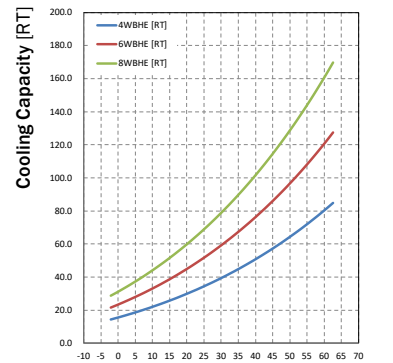

Outer dimensions

*Please consult us for compound performance charts or further details.

[Air cooled type (HFCs)]

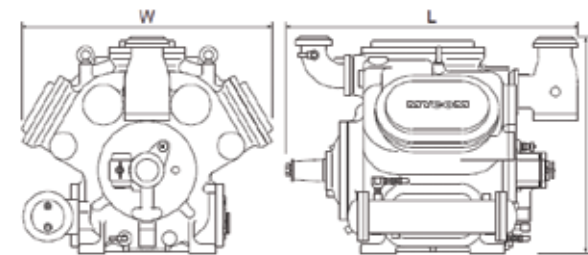

| Model (P/F) | Weight | W | L | H |
|-------------|---------------|------------|------------|-----------|
| 4WBHE | 1929lb/875kg | 39"/990mm | 42"/1075mm | 36"/920mm |
| 6WBHE | 2546lb/1155kg | 42"/1060mm | 49"/1240mm | 36"/915mm |
| 8WBHE | 2745lb/1245kg | 43"/1095mm | 49"/1240mm | 36"/905mm |
| 42WBHE | 2557lb/1160kg | 42"/1065mm | 48"/1225mm | 35"/900mm |
| 62WBHE | 2844lb/1290kg | 43"/1100mm | 49"/1240mm | 37"/950mm |

* The outer dimension drawings illustrate the 6-cylinder model.

* The stop valve, companion flange, flywheel, V-pulley, and safety valve are not included. * The oil cooler is included.

[Water cooled type (Ammonia)]

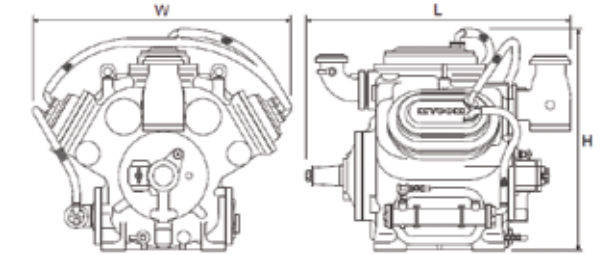

| Model (N) | Weight | W | L | H |
|-----------|---------------|------------|------------|------------|
| 4WBHE | 1962lb/890kg | 41"/1050mm | 42"/1075mm | 36"/920mm |
| 6WBHE | 2601lb/1180kg | 48"/1210mm | 49"/1240mm | 41"/1035mm |
| 8WBHE | 2822lb/1280kg | 50"/1280mm | 49"/1240mm | 42"/1065mm |
| 42WBHE | 2624lb/1190kg | 48"/1210mm | 48"/1225mm | 41"/1035mm |
| 62WBHE | 2932lb/1330kg | 51"/1285mm | 49"/1240mm | 42"/1065mm |

WA-SERIES

Reciprocating Compressor [Single Stage] Open Type & [Two Stage] Open Type



Applications

With a high-pressure design suitable for use in air-cooled condensing units for fluorocarbon refrigerants, the model operates over a wide range of temperature and serves in small to medium scale refrigerating and freezing applications.

[Usable Refrigerants]

Natural Refrigerants

Ammonia
Propane

Fluorocarbon Refrigerants

R134a
R404A
R507A
R23

High Reliability

A long-selling model with high reliability and track record, designed for tough applications subject to load fluctuation.

Performance charts

Ammonia

Condensing temp: 104°F Rotation speed: 970rpm
Suction superheat: 0°F Liquid Subcooling: 9°F

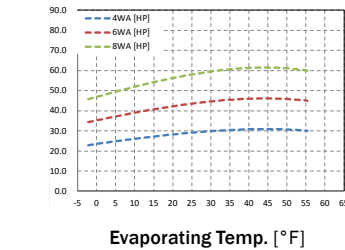
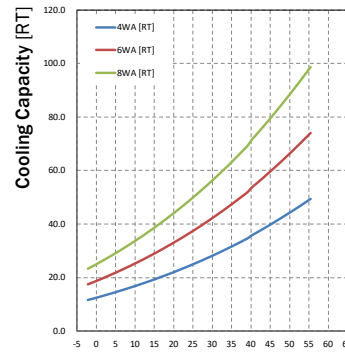

Propane

Condensing temp: 104°F Rotation speed: 970rpm
Suction superheat: 18°F Liquid Subcooling: 9°F

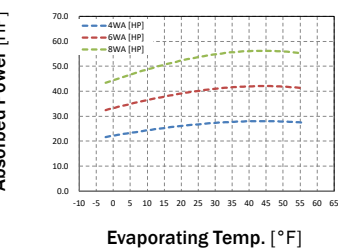
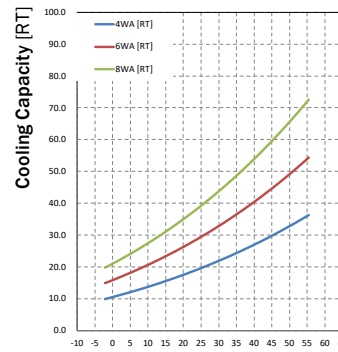

R404A

Condensing temp: 104°F Rotation speed: 970rpm
Suction superheat: 36°F Liquid Subcooling: 9°F

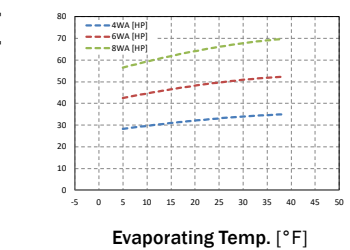
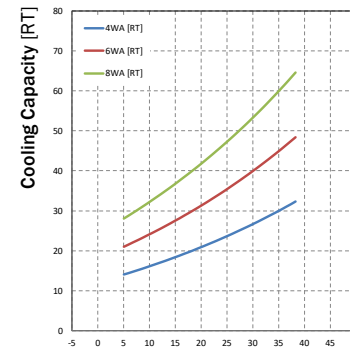

R134a

Condensing temp: 104°F Rotation speed: 970rpm
Suction superheat: 36°F Liquid Subcooling: 9°F

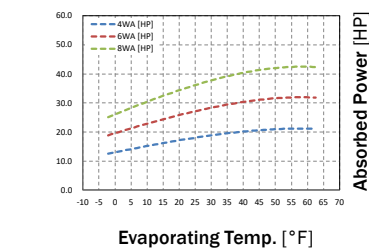
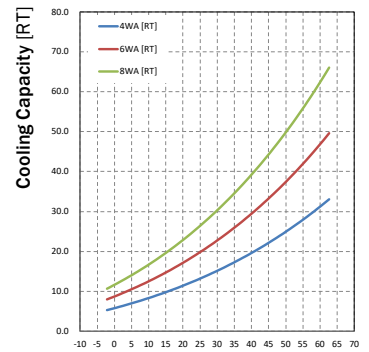

Specifications

*Some optional items are included in this photo.

| Model*1 (N/P/F) | | 4WA | 6WA | 8WA | 42WA | 62WA |
|---------------------|-------------------|---|-----------|--------------|-------------------------------------|--------------------------------------|
| Item | | | | | | |
| Refrigerant | | Ammonia / Propane / HFCs (R134a, R404A, R507A, R23*2) | | | Ammonia / HFCs (R404A, R507A) | |
| Compressor Type | | Reciprocating, Open Type | | | | |
| Number of Cylinders | | 4 | 6 | 8 | Low Stage: 4 High Stage: 2 | Low Stage: 6 High Stage: 2 |
| Bore | | 3.7"/95mm | | | | |
| Stroke | | 2.9"/76mm | | | | |
| Displacement*2 | CFM | 73.6 | 110.7 | 147.7 | Low Stage: 73.6 High Stage: 36.9 | Low Stage: 110.7 High Stage: 36.9 |
| Displacement*2 | m ³ /h | 125 | 188 | 251 | Low Stage: 125 High Stage: 67.2 | Low Stage: 188 High Stage: 62.7 |
| Rotation Speed | rpm | 800-1500*4 | | | | |
| Drive Method | | Direct Drive / V-belt | | | | |
| Capacity Control | % | 100/50 | 100/66/33 | 100/75/50/25 | 100/50 | 100/66/33 |

*1. Specify the refrigerant by adding a prefix to the type code (N = Ammonia / P = Propane / F = Fluorocarbons).

*2. If R23 is to be used as the refrigerant, the machine will come with special specifications. Please contact us for detailed information.

*3. Displacement at 970 rpm

*4. The range of rotation speed varies by operating conditions. Please refer to the ranges of use stated in the operating instructions.

Outer dimensions

*Please consult us for compound performance charts or further details.

[Air cooled type (Propane, HFCs)]

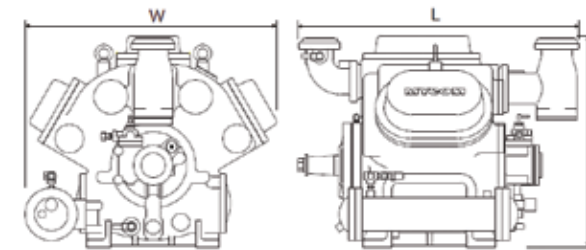

| Model (P/F) | Weight | W | L | H |
|-------------|--------------|-----------|-----------|-----------|
| 4WA | 1014lb/460kg | 30"/760mm | 33"/835mm | 28"/715mm |
| 6WA | 1224lb/555kg | 34"/865mm | 38"/960mm | 26"/725mm |
| 8WA | 1422lb/645kg | 36"/910mm | 39"/980mm | 30"/755mm |
| 42WA | 1279lb/580kg | 33"/850mm | 37"/935mm | 29"/735mm |
| 62WA | 1477lb/670kg | 35"/880mm | 38"/970mm | 30"/750mm |

* The outer dimension drawings illustrate the 6-cylinder model.

* The stop valve, companion flange, flywheel, V-pulley, and safety valve are not included. * The oil cooler is included.

[Water cooled type (Ammonia)]

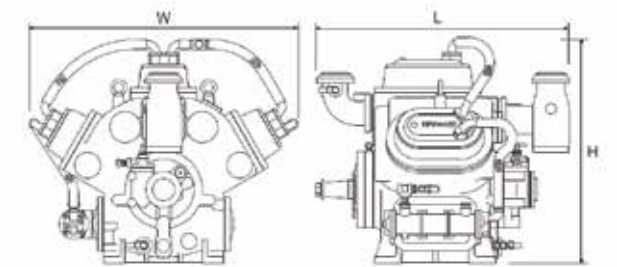

| Model (N) | Weight | W | L | H |
|-----------|--------------|------------|-----------|-----------|
| 4WA | 1047lb/475kg | 34"/875mm | 33"/835mm | 29"/735mm |
| 6WA | 1257lb/570kg | 41"/1050mm | 38"/960mm | 34"/855mm |
| 8WA | 1477lb/670kg | 40"/1020mm | 39"/980mm | 34"/860mm |
| 42WA | 1323lb/600kg | 39"/990mm | 37"/935mm | 33"/840mm |
| 62WA | 1543lb/700kg | 41"/1045mm | 38"/970mm | 36"/910mm |

L-SERIES

Reciprocating Compressor [Single Stage] Open Type



Applications

Developed for exclusive use with ammonia refrigerant, this series of compressors is suitable for refrigeration and freezing applications on land with a smaller load requirement.

Space and Weight Saving Design

A 4-pole motor can be directly connected to the compressor. Hydraulic lines for capacity control are incorporated into the casing design, allowing simplified package designs and easy maintenance.

Covers a Wide Range of Loads

Delivers powerful performance with adaptability to wide operation ranges from 1000 to 1800 rpm.

Performance charts

Ammonia

Condensing temp: 104°F Rotation speed: 970rpm
Suction superheat: 0°F Liquid Subcooling: 9°F

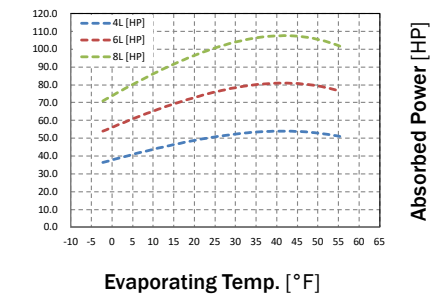
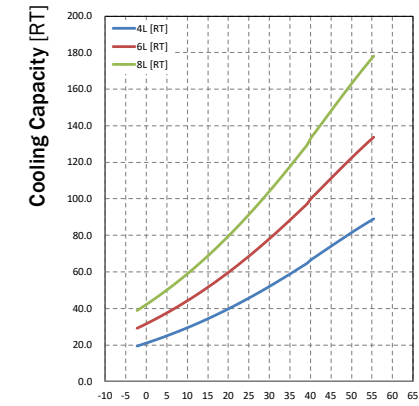

Specifications

*Some optional items are included in this photo.

| Model ^{*1} | | 4L | 6L | 8L |
|----------------------------|-------------------|--------------------------|-----------|--------------|
| Item | | | | |
| Refrigerant | | Ammonia | | |
| Compressor Type | | Reciprocating, Open Type | | |
| Number of Cylinders | | 4 | 6 | 8 |
| Bore | | 4.5"/115mm | | |
| Stroke | | 3.5"/90mm | | |
| Displacement ^{*2} | CFM | 128.3 | 191.9 | 256.0 |
| Displacement ^{*2} | m ³ /h | 218 | 326 | 435 |
| Rotation Speed | rpm | 1000-1800 | | |
| Drive Method | | Direct Drive / V-belt | | |
| Capacity Control | % | 100/50 | 100/66/33 | 100/75/50/25 |

* 1. Specify the refrigerant by adding a prefix "N" for Ammonia to the type code. * 2. Displacement at 970 rpm.

Outer dimensions

*Please consult us for further details.

[Water cooled type (Ammonia)]

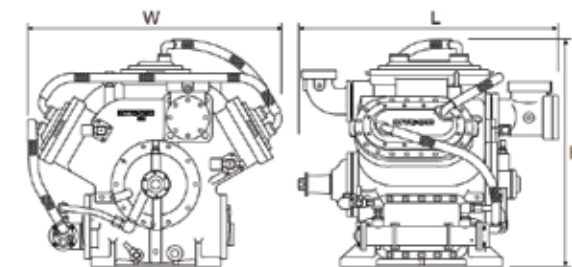

| Model | Weight | W | L | H |
|-------|--------|--------|--------|-------|
| 4L | 630kg | 890mm | 905mm | 840mm |
| 6L | 750kg | 1000mm | 1010mm | 885mm |
| 8L | 875kg | 1060mm | 1040mm | 870mm |

* The outer dimension drawings illustrate the 6-cylinder model.

* The stop valve, companion flange, flywheel, V-pulley, and safety valve are not included.

* The oil cooler is included.

MYCORE-RC100 CONTROL PANEL



Recip Package Panel

MyCore-RC100

Control Panel for MYCOM reciprocating & mini-screw compressors

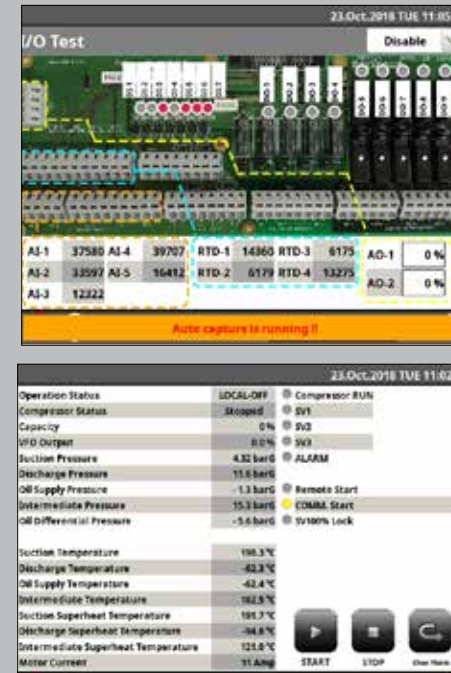

The MyCore-RC100 is the next generation controller replacing MYPRO CP1A and MYPRO iP. This panel has controlling capabilities for MYCOM M, WA/WB, WBHE, HK, L, MHS (1290, 1410), i and other reciprocating compressors.

Standard Features

- » 5.7" resistance film type touch screen
- » Multiple languages
- » USB connection for import & export settings, data logging & screen captures
- » RS-485 communication port provides read & write data using Modbus protocol
- » Ethernet communication provides Modbus TCP/IP protocol
- » Automatic capacity control by suction pressure sensor
- » Manual operation of capacity control, and any PID controllers
- » Self-diagnosis of sensor malfunctions
- » User event function to manage changes of setting valves, and operation logs

Specifications

General Specifications

| | |
|-----------------------|---------------------------------|
| Supply Voltage | 100-240 VAC 50/60 Hz |
| Operating Temperature | 32°F ~ 140°F (0°C ~ 80°C) |
| Ambient Humidity | 85% RH or less (non-condensing) |

IO Specifications

| | | | |
|----------------|-------------------|--|--------|
| Analog Input | Current | 4~20 mA (Input Impedance 250 Ω) | Max. 5 |
| | Voltage | 1-5 VDC (Input Impedance 100k Ω) | |
| | Temperature | 100 Ω Platinum | Max. 4 |
| | Power | 12/24 VDC | |
| Analog Output | Current | 4~20 mA (Resistive Load 500 Ω) | Max. 2 |
| Digital Input | Contact | PNP (24 VDC from base board) | Max. 7 |
| Digital Input | Dry Contact | Dry N.O. contact | Max. 5 |
| | PNP Contact | 24 VDC supplied from controller | Max. 2 |
| Digital Output | Mechanical Relay | 5A at 250 VAC | Max. 4 |
| | Solid State Relay | 0.1A to 2A at 100 to 240 VAC Leakage: 1.5 mA max at 200 VAC | Max. 5 |

Oil Pumps MP & FP Series

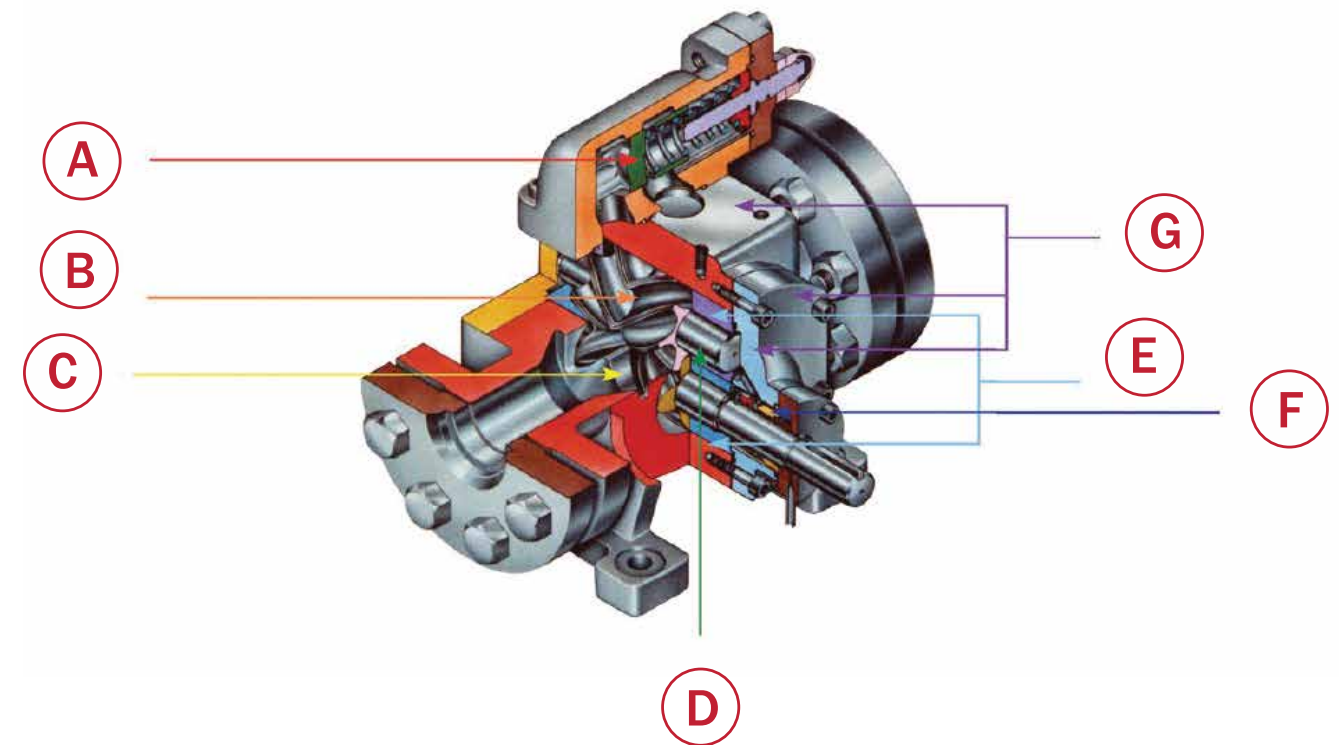

A

Integral Pressure Relief Valve

- Smooth response to the change in pressure
- High durability
- Sludge free structure
- Less noise

B

Special Rotors

- Smooth rotation due to thrust offset rotor design
- Asymmetric rotor design assures smooth contact
- High durability

C

Optimum Suction and Discharge Ports

- Optimum port design to assure smooth fluid transfer

D

Special Rotor Shaft

- Special material as well as treatment for longer life expectancy

E

Special Thrust Bearing

- Higher reliability and quality

F

High Resistance Mechanical Seal

- Balanced type structure eliminates the leakage
- Special material assures the longer resistance against the leakage
- No suction pressure to be on the seal suction

G

Casing and Cover

- Durable design and material to prevent against high pressure

OIL PUMPS

MP & FP Series
M50P/M60P/M80P/
M100P/M125P/FP50/FP60



MYCOM oil pumps are gear mesh type which employ a screw rotor design. They are suitable for screw compressor lubrication systems.

Longer life

Industry-proven durability with no thrust load screw gear structure

Low noise, low vibration

With integral pressure-regulating valve which creates an uncomplicated lube system (the relief valve can cover up to 50% of the total flow).

Open type (MP series) and C-flange type (FP series) are available.

Specifications

***Special Line-up**

| Model | M50PH | M60PH | M80PH | M100PH | M125PH |
|--------------------------------|-------|-------|-------|--------|--------|
| Design Pressure [psig] | 435 | N/A | 435 | 435 | 435 |
| Max. Outlet Pressure [psig] *3 | 435 | N/A | 435 | 435 | 435 |
| Max. Outlet Pressure [psig] *4 | 435 | N/A | 435 | 435 | N/A |
| Max. Inlet Temperature [F] | 266 | | | | |

* 3. Cast iron casing with tandem shaft.
 * 4. Cast steel casing with tandem shaft. This pump has ANSI#300 flanges available.
 ** All other items are the same as the standard.

Outer dimensions

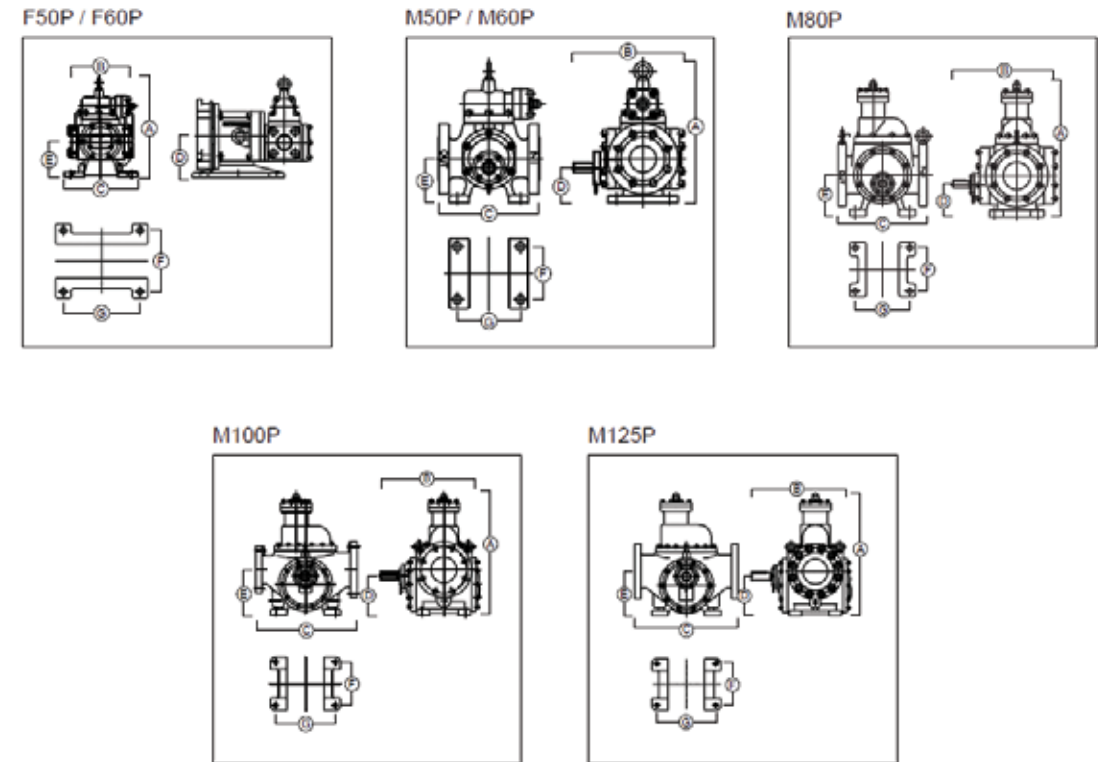

Specifications

***Standard Line-up**

| Model | M50P | M60P | M80P | M100P | M125P | FP50 | FP60 |
|-------------------------------|-------------------|-------|--------------|---------|---------|-------|-------|
| Maximum Speed [rpm] | 1750 | 1750 | 1750 | 1450 | 1150 | 1750 | 1750 |
| Minimum Speed [rpm] | 950 | 950 | 720 | 720 | 720 | 950 | 950 |
| Rotation *1 | CW | CW | CW | CCW | CCW | CCW | CCW |
| Std Flow Direction *1 | R → L | R → L | R → L | R → L | R → L | R → L | R → L |
| Capacity @50CST [GPM] | 17-33 | 35-68 | 76-138 | 112-224 | 225-357 | 17-33 | 35-68 |
| Design Pressure [psig] | 377 | 377 | 377 | 377 | 377 | 377 | 377 |
| Max. Outlet Pressure [psig] | 362 | 319 | 362 | 362 | 362 | 319 | 319 |
| Min. Inlet Pressure [psig] | -4.3 | | | | | | |
| Differential Pressure | with Relief Valve | | Max. 58 psi | | | | |
| | w/o Relief Valve | | Max. 290 psi | | | | |
| Max. Inlet Temperature [F] *2 | 176 | | | | | | |
| Viscosity of Fluid [cst] | 3 - 500 | | | | | | |
| Oil Strainer Before Pump | ≥ 150 μm | | | | | | |

* 1. Reverse rotation and reverse flow direction is available upon request.
 * 2. Higher temperature is available up to 266 deg. F.

| Model | A | B | C | D | E | F | G |
|-----------|-----------|-----------|-----------|----------|-----------|-----------|-----------|
| F50P/F60P | 13"/335mm | 24"/601mm | 6"/150mm | 6"/145mm | 5"/125mm | 7"/170mm | 9"/220mm |
| M50P | 13"/320mm | 10"/251mm | 9"/230mm | 3"/80mm | 4"/100mm | 5"/120mm | 6"/144mm |
| M60P | 13"/330mm | 12"/295mm | 9"/230mm | 3"/80mm | 4"/100mm | 5"/120mm | 6"/144mm |
| M80P | 20"/495mm | 15"/382mm | 13"/330mm | 5"/118mm | 6"/150mm | 7"/160mm | 8"/200mm |
| M100P | 23"/588mm | 19"/476mm | 20"/490mm | 8"/190mm | 9"/220mm | 9"/210mm | 12"/290mm |
| M125P | 28"/709mm | 23"/578mm | 24"/600mm | 9"/225mm | 10"/255mm | 10"/240mm | 14"/340mm |

* Information shown here is for reference only. Subject to change without notice. Please contact Mayekawa for details.

Measurements are in mm [inches].

Genuine OEM

MANUFACTURED PARTS

MYCOM's genuine OEM parts are designed to ensure the longevity of your MYCOM Compressor. A long lasting product paired with a great warranty equals more money in your pocket. To buy MYCOM OEM parts, contact a Mayekawa office or contact the sales representative in your area. You can find a list of sales representatives by location at:

www.mayekawausa.com/industrial-refrigeration/contact-us/



To purchase MYCOM Genuine OEM parts, call a sales rep in your area, contact one of the Mayekawa offices listed below or send an email to info@mayekawausa.com.

SALES REPRESENTATIVES

| Sales Rep | Phone Number | Address | Territory |
|---|------------------------------|---|--|
| Clark Johnson Company, Inc. | 714-521-6161 | 14747 Artesia Blvd, 2-E La mirada, CA 90638 | Arizona, California, Nevada, Utah |
| Freeze-Pro, Inc. | 904-531-5065 | 3516 Enterprise Way, Suite 3, Green Cover Springs, FL 32043 | Alabama, Florida, Georgia |
| Stanton & Associates, Inc. | 574-247-5522 | 6910 N. Main Street, Unit 15 Granger, IN 46530 | Iowa, Illinois, Indiana, Kentucky, Michigan, Minnesota, North Dakota, Ohio, South Dakota, Wisconsin |
| IREP | 206-941-8095 604-219-6049 | 1540 NE 95th Street Seattle, WA 98115 | Idaho, Montana, Oregon, Washington |
| South West Refrigeration Sales, SWR Sales, LLC. | 210-492-8024 | 19141 Stone Oak Pkwy #104 San Antonio, TX 78258 | Arkansas, Colorado, Kansas, Louisiana, Missouri, Mississippi, Nebraska, New Mexico, Oklahoma, Tennessee, Texas, Wyoming |
| James Buffington | 615-773-2859 | 130 Smart Park Drive Lebanon, TN 37090 | Connecticut, Delaware, District of Columbia (Washington DC), Massachusetts, Maryland, Maine, North Carolina, New Hampshire, New Jersey, New York, Pennsylvania, Rhode Island, South Carolina, Virginia, Vermont, West Virginia |
| Luis Popa | 809-271-5507 | C/ Rubén Dario No. 25, Ens. Enriquillo, Herrera, Santo Domingo Oeste, R.D. | Dominican Republic |

MAYEKAWA USA OFFICES FOR PARTS SALES

York

3395 Farmtrail Rd.
York, PA 17406
717-779-0138

Torrance

19475 Gramercy Place
Torrance, CA 90501
310-328-1362