

Vogt.

TubeIce | Turbo



ICE SIZER MANUAL

Vogt.
TubeIce | Turbo

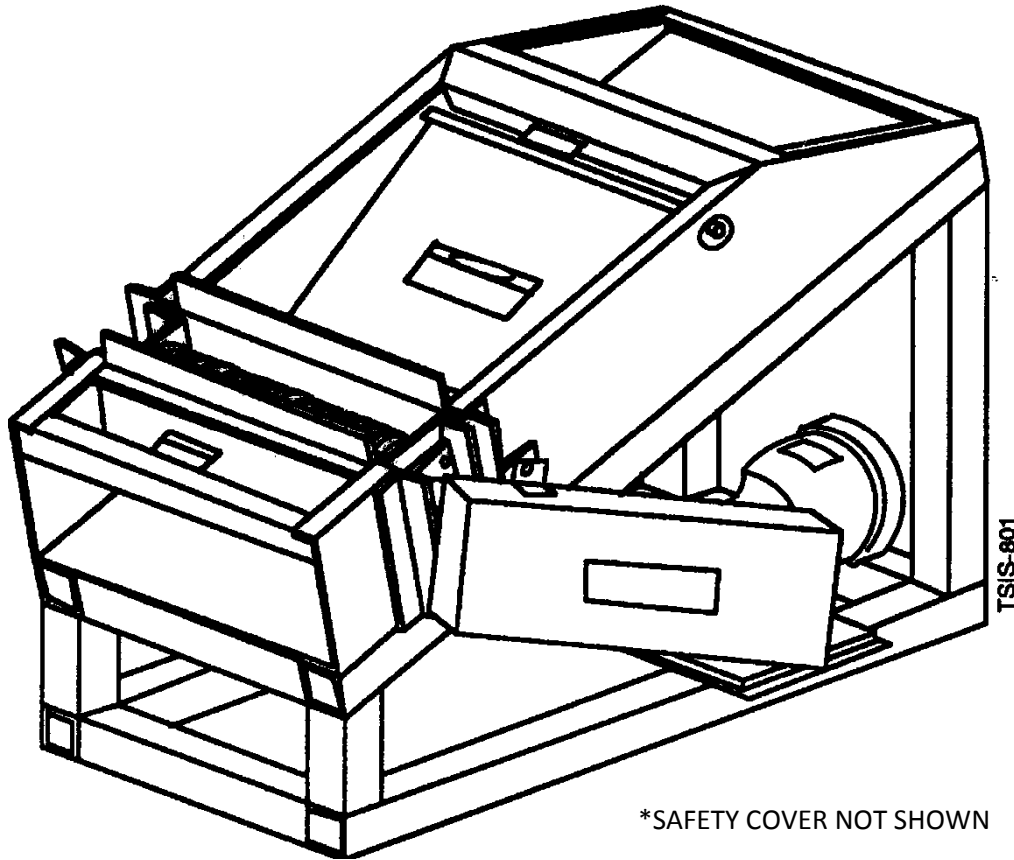

Ice Sizer

Installation and Operation Instructions

Vogt Ice, LLC
1000 West Ormsby Avenue, Suite 19
Louisville, KY 40210
Phone: (502) 635-3000
Email: info@vogtice.com
www.vogtice.com



**ICE SIZER
INSTALLATION & OPERATION
INSTRUCTIONS**

**INTRODUCTION
TERMS & CONDITIONS** **1**

SAFETY **2**

**INSTALLATION
REQUIREMENTS** **3**

**OPERATING
INSTRUCTIONS** **4**

**SERVICE AND
TROUBLE-SHOOTING** **5**



CONTENTS



SECTION 1

Figures & Tables

iii

Introduction

1

History 1

Icemakers Versus Ice Generators 1

Turbo Icemakers 1

Turbo Ice Generators 1

Models 2

TIG Series Models 2

SC (Self-Contained) 2

SCA (Self-Contained Air-Cooled) 2

SCE (Self-Contained Evaporative-Cooled
Condenser) 2

SCAR (Self-Contained Air-Cooled Remote) 2

SCER (Self-Contained Evaporative Remote) 2

TIGAR Series Models 2

R (Remote Evaporator) 2

AR (Ammonia Remote) 2

Capacities 3

USDA Approved 3

Sanitary Ice 3

Controls 3

Ice Delivery 3

Associated Turbo Equipment 4

Turbo Block Press 4

Turbo Ice Rake 4

Typical Applications 4

Customer Service 4

High Values 4

Terms & Conditions

5

Terms and Prices 5

Shipment 5

Delivery 5

Limited Warranty: Warranty Adjustment: Exclusions:

Limitation of Liability 5

Patents 7

Prior Use 7

Equipment Changes 7

Security Interest: Insurance 7

Cancellation 8

Loss, Damage or Delay 8

Work By Others: Accessory and Safety Devices 8

Complete Agreement 8

SECTION 2	Safety 9 Safety Definitions 9 Warning 9 Caution 9 Important 9 Note 9 Machinery is Dangerous 9 Involve Your People 10 WARNINGS 10 Conveyor Manufacturer's Instructions and Warnings 13 Safety Lockout Procedure 15 I. Purpose 15 II. Scope 15 III. Supervisory Responsibility 15 IV. Safety Locks 15 V. Safety Department Responsibility 15 VI. Rules and Regulations 15 VII. Outside Contractors 16 VIII. Failure To Follow Procedures 16
SECTION 3	Installation Requirements 17 Installation 17 Electrical Components 18 Drive Motor 18 Controls 20
SECTION 4	Operating Instructions 21 Introduction 21 Typical Ice Sizer Sequence 21 Metering Arm 21
SECTION 5	Service and Trouble-Shooting 23 Clearing Ice Obstructions 23 Ice Sizer Mechanism Service 23



FIGURES & TABLES



SECTION 2

Safety

9

Figure 2-1	Warning Label on the Ice Sizer	9
Figure 2-2	Warning Label on the Ice Sizer Protective Covers	10
Figure 2-3	Location of Safety Labels	11
Figure 2-4	Warning Labels on the Screw Conveyor	11

SECTION 3

Installation Requirements

17

Figure 3-1	Ice Feed	17
Figure 3-2	Framing Dimensions for Inlet and Outlet Transitions	18
Figure 3-3	Ice Sizer Configuration	19
Figure 3-4	Ice Sizer Base Frame Dimensions	19
Figure 3-5	Limit Switch Specifications	20
Figure 3-6	Limit Switch Wiring	20



INTRODUCTION



Turbo Refrigerating Company is a supplier of ice making and ice storage equipment. Turbo does not engineer or design ice systems or ice plants.

Information on safety, installation, operation, maintenance, and trouble shooting is contained in this manual. If you have questions concerning any of these phases, contact Turbo Refrigerating Company or one of its distributors to ensure you fully understand the instructions and guidelines.

You must read all of the information carefully and make sure that all personnel involved in the installation and operation have also read and understood the information and safety instructions. This will help avoid injury to personnel and/or damage to the equipment. Both are valuable assets to your operation. Take the time to protect them.

Read the manual contents before you start your installation or operation. This will save time by ensuring all the necessary materials and tools are available when the equipment arrives.

History

Turbo Refrigerating Company has been producing equipment for the ice industry since

1960. The ice sizer described in this manual is part of a family of products designed specifically to meet the needs of the ice users. The ice sizers were introduced in 1988. Although they are the youngest member of the Turbo family, they are built with the same high quality standards of engineering used to develop the icemakers of the 60's.

The ice sizer reduces the amount of snow produced in the system which means more product sales and higher profits. The entire breaker bar drive and breaker bar mechanism can be eliminated from the icemaker. This reduces the number of moving components in most systems and thus minimizes maintenance. The sizing of the ice is much more uniform, resulting in a higher quality product.

The Turbo ice sizer can be used with a variety of icemakers and ice generators. Described below are the basic differences between the Turbo icemaker and the Turbo ice generator.

Icemakers Versus Ice Generators

There are several basic differences between Turbo icemakers (C-series) and Turbo ice generators (TIG/TIGAR series).

Turbo Icemakers

The traditional Turbo icemaker was designed to meet the needs of the packaged ice industry where dry, sub-cooled, uniform pieces of ice are essential. To meet these requirements, Turbo icemakers make ice on only one side of the plate and warm water is used to harvest (some models are available with hot gas assist). The water to each section is cut-off and a drying cycle is used. Both of the above ensure a dry, sub-cooled ice. As the ice separates from the plates, it is metered into a breaker assembly to ensure uniform ice size. The sizing system consists of:

- a rotating breaker bar
- an adjustable sizer bar
- a fixed sizer grate.

The unique sizing adjustment along with ice thickness controls allow the Turbo icemaker to produce a wide variety of ice nugget sizes.

Turbo Ice Generators

The Turbo ice generators were designed to meet the needs of the industrial user requiring ice for its cooling effect rather than for consumption. TIG/TIGAR series units maintain the same operating technology, and sanitation requirements as the icemakers maintain, while eliminating the icemaker features not essential to their applications. In the TIG/TIGAR, the drying cycle and warm water harvest are

Read Safety Section before installing or using equipment.

replaced by a hot gas harvest, and the ice breaker/sizer mechanism is replaced by a auger to break the ice into irregular sizes. As a result, a random shaped piece of fragmented ice is produced at a lower cost per ton.

When used with the ice sizer:

- the rotating breaker bar
- the adjustable sizer bar
- and the fixed sizer grate

are not required on the Turbo icemakers. These features (described previously) have already been eliminated on the Turbo ice generators. With both the Turbo icemaker and ice generator, the final product sizing is done by the ice sizer.

Models

All TIG/TIGAR units are provided with:

- stainless steel exterior panels (optional aluminum panels available)
- control panel with programmable controller
- stainless steel ice slide
- stainless steel evaporator plates
- 230/3/60 or 460/3/60 motor with 115/1/60 controls
- multiple evaporator sections
- open compressors direct-coupled to an open-drip-proof motor
- stainless steel water distribution pan.

All surfaces in contact with the water or ice are either stainless steel, PVC, or hot-dipped galvanized for maximum sanitation and corrosion resistance.

TIG Series Models

SC (Self-Contained)

- Completely self-contained, including refrigerant charge.
- Uses a water-cooled condenser with water regulating valves.
- Optional cooling tower and pump are available.

SCA (Self-Contained Air-Cooled)

- Completely self-contained, including refrigerant charge.
- Uses an air-cooled condenser.
- Head pressure controls provided with the air-cooled condenser.
- Complete unit and condenser is mounted on a common base frame.

SCE (Self-Contained Evaporative-Cooled Condenser)

- Completely self-contained, including refrigerant charge.
- Uses an evaporative-cooled condenser.
- Head pressure controls provided with the evaporative-cooled condenser.
- Complete unit and condenser is mounted on a common base frame.

SCAR (Self-Contained Air-Cooled Remote)

- Self-contained unit set up for remote air-cooled condenser.
- Air-cooled condenser and head pressure controls can be furnished as options.
- No refrigerant charge.
- Receiver and isolating valves are optional.

SCER (Self-Contained Evaporative Remote)

- Self-contained unit set up for remote evaporative-cooled condenser.
- Evaporative-cooled condenser and head pressure controls can be furnished as options.
- No refrigerant charge.
- Receiver and isolating valves are optional.

R (Remote Evaporator)

- Low side evaporator including Turbo suction accumulator/heat exchanger for connection to remote high side equipment.
- No refrigerant charge provided.

TIGAR Series Models

AR (Ammonia Remote)

- Ammonia evaporator set up for connection to a remote ammonia recirculation and high side equipment.
- Contains all controls for icemaking and electrical interface with remote refrigeration equipment.
- Ammonia high side and recirculation packages can be furnished as options.
- No charge provided.

Capacities

The TIG series is available in 18, 21, 33, 42, 64, and 85 tons of ice per day models. The TIGAR series is available in 25, 50, 75, and 100 tons of ice per day models. All capacities are based on 60° F make-up water, 0° F evaporator and 95° F condensing temperatures.

USDA Approved

All Turbo TIG/TIGAR series ice generators have preliminary USDA approval and are built to meet rugged industrial standards which make them the most reliable in the industry. Each system is designed to provide the safest and simplest operation as well as to minimize maintenance.

Turbo icemakers are USDA approved.

Sanitary Ice

Turbo makes every effort possible to minimize the potential for contamination of the ice produced on the ice generators and icemakers (as well as all other products). All water and ice contact areas are either stainless steel, PVC, or hot-dipped galvanized. In addition, the stainless steel water distribution pan is open and easily accessible for cleaning on TIG models. PVC water distribution tubes are used on icemakers.

The hole pattern in the water distribution pan on ice generators acts as a secondary screening media for the water on the plates. A strainer is provided in the make-up water line. Turbo strongly urges each user to consult a local water treatment specialist to determine any water treatments that might be beneficial in obtaining the best ice possible.

Controls

Turbo ice generators use the latest controls available for simple, reliable operation. All models are supplied with:

- a programmable controller
- magnetic starters with overload protection (for all motors furnished with the ice generator - extra starters for remote equipment are optional)
- all selector switches required for automatic operation of the system.

All components are mounted in a stainless steel electrical enclosure (UL 3R). Control panels are UL approved.

Turbo icemakers use electro-mechanical controls. Optional programmable controllers are available.

Ice Delivery

Ice produced by the ice generator is delivered to a common ice discharge opening outside the cabinet of all models. The discharge opening is a standard screw conveyor down spout. Turbo recommends that an inclined transfer screw conveyor or belt conveyor be used to transfer the ice from the ice discharge to its final delivery point. Such arrangements prevent any condensation or water from:

- accidentally dumping into the system
- draining or flowing into the final icing points.

IMPORTANT

All conveyors, transitions, or belts connecting to the ice discharge should ensure that access into the screw conveyor (auger) is eliminated. See Safety Section on page 9.

If you have an application or a need that is not discussed here, contact the sales department of Turbo Refrigerating Company or a Turbo distributor to discuss your needs:

TURBO REFRIGERATING CO
1000 WEST ORMSBY AVENUE
SUITE 19
LOUISVILLE, KY 40210
PHONE: 940-387-4301
TOLL FREE 800-775-8648

Associated Turbo Equipment

Turbo Block Press

Turbo offers another feature to make it possible to get your money's worth out of your ice production. Instead of throwing away the snow produced by the breaker bar, screw conveyors or other handling devices, install a Turbo block press. The Turbo block press converts the snow into a ten or fifty-five pound block of ice.

Introduced in 1977, the Turbo block press is a completely automatic hydraulic powered unit capable of producing from 120 to an excess of 400 ten pound blocks per hour.

The Turbo block press is available with a block bagger attachment which again means:

- less handling
- a better product
- higher profits for the ice person.

Rugged industrial construction and stainless steel in all areas of ice contact make the Turbo block press the most reliable on the market.

Turbo Ice Rake

Turbo offers the only proven automatic ice storage and delivery system (from 20 to 300 ton capacities).

There are two basic sizes in the hydraulic version as well as two larger versions known as "automatic ice rakes". The smaller hydraulic models range in capacity from 20 to 75 tons while the larger automatic ice rakes range from 100 to 300 tons of ice storage.

All Turbo ice storage systems are USDA approved or tentatively approved. Each system is designed to make the loading and unloading of the ice storage system as safe and simple as possible. Turbo ice rakes are self-leveling and self-unloading.

Typical Applications

- produce (broccoli, carrots, etc.)
 - top icing in the field or in the processing area
 - units can be trailer mounted
- concrete icing
- ingredient icing (as in bakeries)
- fish icing
- poultry icing
- chemical and dye processes
- emergency cooling loads
- ice slurries
- catering trucks
- salad bars or display ice
- food processing.

Customer Service

The Turbo service department provides assistance for all customer needs. Turbo conducts training schools at the factory and various locations throughout the world. For information, contact the service department at Turbo Refrigerating Company.

The model and serial number of your Turbo equipment is located on the nameplate attached to the electrical control panel. Please refer to the model and serial number when making inquiries about the equipment. This will enable our personnel to handle your questions quickly and accurately.

High Values

Turbo highly values its friends and customers in the industry. Please remember to:

- T**hink safely - act safely.
- U**nderstand operating procedures and dangers of the equipment.
- R**emember to think before you act.
- B**efore you act, understand the consequences of your actions.
- O**bserve equipment warnings and labels.



TERMS & CONDITIONS



Turbo Refrigerating Co. (the "Company") agrees to sell the Equipment described herein upon the following terms and conditions of sale which, accordingly, supersede any of Buyer's additional or inconsistent terms and conditions of purchase.

1. TERMS AND PRICES

(a) All orders are to be accompanied by a twenty percent (20%) down payment or an acceptable irrevocable letter of credit confirmed on a U.S. Bank acceptable to Turbo. No orders are to be entered without payment or L/C in hand.

(b) All orders are subject to the approval of the Company's home office. Unless otherwise stated, standard terms of payment are thirty (30) days net from the earlier of date of shipment or readiness of the Equipment for shipment. If partial shipments are made, payment shall become due and payable to the partial shipment.

(c) In addition to the purchase price, Buyer shall pay any excise, sales, privilege, use or any other taxes, Local, State or Federal, which the Company may be required to pay arising from the sale or delivery of the Equipment or the use thereof. Prepaid freight, if applicable, will be added to the purchase price and invoiced separately. Where price includes transportation

or other shipping charges, any increases in transportation rates or other shipping charges from date of quotation or purchase order shall be for the account of and paid by Buyer.

(d) Contract prices are subject to adjustment to the Company's prices in effect at time of shipment unless otherwise specified in a separate Price Adjustment Policy attached to the proposal or other contract document of the Company.

(e) If Buyer requests changes in the Equipment or delays progress of the manufacture or shipment of the Equipment, the contract price shall be adjusted to reflect increases in selling price caused thereby.

2. SHIPMENT

Shipment is F.O.B. Company's plant or place of manufacture, unless otherwise specified. Risk of loss shall pass to Buyer upon delivery to transporting carrier.

3. DELIVERY

(a) The Company will endeavor to make shipment of orders as scheduled. However, all shipment dates are approximate only, and the Company reserves the right to readjust shipment schedules.

(b) Under no circumstances will the Company be responsible or incur any liability for costs or damages of any nature (whether general, conse-

quential, as a penalty or liquidated damages or otherwise) arising out of or owing to (i) any delays in delivery or (ii) failure to make delivery at agreed or specified times due to circumstances beyond its reasonable control.

(c) If shipment is delayed or suspended by Buyer, Buyer shall pay (i) Company's invoice for the Equipment as per payment terms, (ii) Company's handling and storage charges then in effect, and (iii) demurrage charges if loaded on rail cars.

4. LIMITED WARRANTY: WARRANTY ADJUSTMENT: EXCLUSIONS: LIMITATION OF LIABILITY

(a) LIMITED WARRANTY
The Company warrants that at the time of shipment the Equipment manufactured by it shall be merchantable, free from defects in material and workmanship and shall possess the characteristics represented in writing by the Company. The Company's warranty is conditioned upon the Equipment being properly installed and maintained and operated within the Equipment's capacity under normal load conditions with competent supervised operators and, if the Equipment uses water, with proper water conditioning. Equipment, accessories and other parts and components not manufactured by the

Read Safety Section before installing or using equipment.

Company are warranted only to the extent of and by the original manufacturer's warranty to the Company, in no event shall such other manufacturer's warranty create any more extensive warranty obligations of the Company to the Buyer than the Company's warranty covering Equipment manufactured by the Company.

(b) EXCLUSIONS FROM WARRANTY

(i) THE FOREGOING IS IN LIEU OF ALL OTHER WARRANTIES, ORAL OR EXPRESS OR IMPLIED, INCLUDING ANY WARRANTIES THAT EXTEND BEYOND THE DESCRIPTION OF THE EQUIPMENT. THERE ARE NO EXPRESS WARRANTIES OTHER THAN THOSE CONTAINED IN THIS PARAGRAPH 4 AND TO THE EXTENT PERMITTED BY LAW THERE ARE NO IMPLIED WARRANTIES OF FITNESS FOR A PARTICULAR PURPOSE. THE PROVISIONS OF THIS PARAGRAPH 4 AS TO DURATION, WARRANTY ADJUSTMENT AND LIMITATION OF LIABILITY SHALL BE THE SAME FOR BOTH IMPLIED WARRANTIES (IF ANY) AND EXPRESS WARRANTIES.

(ii) The Company's warranty is solely as stated in (a) above and does not apply or extend, for example, to expendable items, ordinary wear and tear, altered units; units repaired by persons not expressly approved by the Company, materials not of the Company's manufacture, or damage caused by accident, the ele-

ments, abuse, misuse, temporary heat, over-loading, or by erosive or corrosive substances or by the alien presence of oil, grease, scale, deposits or other contaminants in the Equipment.

(c) WARRANTY ADJUSTMENT

Buyer must make claim of any breach of any warranty by written notice to the Company's home office within thirty (30) days of the discovery of any defect. The Company agrees at its option to repair or replace, **BUT NOT INSTALL, F.O.B.** Company's plant, any part or parts of the Equipment which within twelve (12) months from the date of initial operation but no more than eighteen (18) months from date of shipment shall prove to the Company's satisfaction (including return to the Company's plant, transportation prepaid, for inspection, if required by the Company) to be defective within the above Warranty. Any warranty adjustments made by the Company shall not extend the initial warranty period set forth above. The warranty period for replacements made by the Company shall terminate upon the termination of the initial warranty period set forth above. Expenses incurred by Buyer in replacing or repairing or returning the Equipment or any part or parts will not be reimbursed by the Company.

(d) SPARE AND REPLACEMENT PARTS WARRANTY ADJUSTMENT

The Company sells spare and replacement parts. This sub-

paragraph (d) is the Warranty Adjustment for such parts. Buyer must make claim of any breach of any spare or replacement parts warranty by written notice to the Company's home office within thirty (30) days of the discovery of any alleged defect for all such parts manufactured by the Company. The Company agrees at its option to repair or replace, **BUT NOT INSTALL, F.O.B.** Company's plant, any part or parts of material it manufactures which, within one (1) year from the date of shipment shall prove to the Company's satisfactory (including return to the Company's plant, transportation prepaid, for inspection, if required by the Company) to be defective within this Parts Warranty. The Warranty and warranty period for spare and replacement parts not manufactured by the Company (purchased by the Company, from third party suppliers) shall be limited to the Warranty and Warranty Adjustment extended to the Company by the original manufacturer of such parts, in no event shall such other manufacturer's warranty create any more extensive warranty obligation of the Company to the Buyer for such parts than the Company's Warranty Adjustment covering parts manufactured by the Company as set forth in this subparagraph (d). Expenses incurred by the Buyer in replacing, repairing, or returning the spare or replacement parts will not be reimbursed by the Company.

(e) LIMITATION OF LIABILITY

The above Warranty Adjust-

ment sets forth Buyer's exclusive remedy and the extent of the Company's liability for breach of implied (if any) and express warranties, representations, instructions or defects from any cause in connection with the sale or use of the Equipment. THE COMPANY SHALL NOT BE LIABLE FOR ANY SPECIAL, INDIRECT OR CONSEQUENTIAL DAMAGES OR FOR LOSS, DAMAGE OR EXPENSE, DIRECTLY OR INDIRECTLY ARISING FROM THE USE OF THE EQUIPMENT OR FROM ANY OTHER CAUSE WHETHER BASED ON WARRANTY (EXPRESS OR IMPLIED) OR TORT OR CONTRACT, and regardless of any advices or recommendations that may have been rendered concerning the purchase, installation or use of the Equipment.

5. PATENTS

(a) PATENT INDEMNITY AND CONDITIONS

The Company agrees at its own expense to defend and hold Buyer harmless in the event of any suits instituted against Buyer for an alleged infringement of any claim of any United States Patent covering solely to the structure of the Equipment as originally manufactured by the Company per the Company's specifications, and without modification by the Buyer, provided buyer shall (i) have given the Company immediate notice in writing of any such claim or institution or threat of such suit, and (ii) have permitted the Company to defend or

settle the same, and have given all needed information assistance and authority to enable the Company to do so. Buyer shall defend and indemnify the Company against all expenses, costs and loss by reason of any real or alleged infringement by the Company's incorporating a design or modification requested by Buyer.

(b) LIMITATION OF LIABILITY

The Company's total liability hereunder is expressly limited to an amount no greater than the sales price of the Equipment and may be satisfied by the Company's refunding to Buyer, at the Company's option, the sales price of the Equipment in the event the Company elects to defend any such suit and the structure of the said Equipment is held to infringe any such United States Patent and if the Buyer's use thereof is enjoined, the Company shall, at its expense and at its option (i) obtain for the Buyer the right to continue using the Equipment, or (ii) supply non-infringing Equipment for installation by Buyer, or (iii) modify the Equipment so that it becomes non-infringing, or (iv) refund the then market value of the Equipment.

6. PRIOR USE

If damage to the Equipment or other property or injury to persons is caused by use or operation of the Equipment prior to being placed in initial operation ("Start up") by the Company where start up is included in the purchase price,

then Buyer shall indemnify and hold the Company harmless from all liability, costs and expenses for all such damage or injury.

7. EQUIPMENT CHANGES

The Company may, but shall not be obligated to, incorporate in the Equipment any changes in specifications, design, material, construction, arrangement, or components.

8. SECURITY INTEREST: INSURANCE

(a) To secure payment of the purchase price, Buyer agrees that the Company shall retain a security interest in the Equipment until Buyer shall have paid in cash the full purchase price when due, interest at the highest lawful contract rate until so paid and the costs of collection, including reasonable attorney's fees. The Equipment shall at times be considered and remain personal property and Buyer shall perform all acts necessary to assure and perfect retention of the Company's security interest against the rights or interests of third persons. In the event Buyer defaults in payment of any part of the purchase price when due, or fails to comply with any and all provisions of this contract, the Company shall have the remedies available under the Uniform Commercial Code.

(b) So long as the purchase price is unpaid, Buyer at its

cost shall obtain insurance against loss or damage from all external causes, naming the Company as an insured, in an amount and form sufficient to protect the Company's interest in the Equipment.

9. CANCELLATION

Buyer cannot cancel orders placed with the Company, except with the Company's express written consent and upon terms and payment to the Company indemnifying the Company against loss, including but not limited to expenses incurred and commitments made by the Company.

10. LOSS, DAMAGE OR DELAY

The Company shall not be liable for loss, damage or delay resulting from causes beyond its reasonable control or caused by strikes or labor difficulties, lockouts, acts or omissions of any governmental authority or the Buyer, insurrection or riot, war, fires, floods, Acts of God, breakdown of essential machinery, accidents, priorities or embargoes, car and material shortages, delays in transportations or inability to obtain labor, materials or parts from usual sources. In the event of any delay from such sources, per-

formance will be postponed by such length of time as may be reasonably necessary to compensate for the delay. In the event performance by the Company of this agreement cannot be accomplished by the Company due to any action of governmental agencies, or any laws, rules or regulations of the United States Government, the Company (at its option) may cancel this agreement without liability. In no event shall the Company be liable for any loss or damage of any kind, including consequential or special damages of any nature.

11. WORK BY OTHERS: ACCESSORY AND SAFETY DEVICES

The Company, being only a supplier of the Equipment, shall have no responsibility for labor or work of any nature relating to the installation or operation or use of the Equipment, all of which shall be performed by Buyer or others. It is the responsibility of Buyer to furnish such accessory and safety devices as may be desired by it and/or required by law or OSHA standards respecting Buyer's use of the Equipment. Buyer shall be responsible for ascertaining that the Equipment is installed and operated in ac-

cordance with all code requirements and other applicable laws, rules, regulations and ordinances.

12. COMPLETE AGREEMENT

THE COMPLETE AGREEMENT BETWEEN THE COMPANY AND BUYER IS CONTAINED HEREIN AND NO ADDITIONAL OR DIFFERENT TERM OR CONDITION STATED BY BUYER SHALL BE BINDING UNLESS AGREED TO BY THE COMPANY IN WRITING.

No course of prior dealings and no usage of the trade shall be relevant to supplement or explain any terms used in this Agreement. This Agreement may be modified only by a writing signed by both the Company and Buyer and shall be governed by the Uniform Commercial Code as enacted the State of Texas. The failure of the Company to insist upon strict performance of any of the terms and conditions stated herein shall not be considered a continuing waiver of any such term or condition or any of the Company's rights.

WARNING! Read this section first. Failure to carefully follow these instructions could result in permanent injury or loss of life.



SAFETY



Here are some safety points to keep in mind when creating an efficient yet safe working environment.

Safety Definitions

Statements or labels in this manual or on the product preceded by the following words are of special significance:

Warning

Indicates severe personal injury or death will result if instructions are not followed.

Caution

Indicates a strong possibility of severe personal injury or death if instructions are not followed.

Important

Means hazards or unsafe practices which could cause minor personal injury or product or property damage.

Note

Gives helpful information.

Machinery is Dangerous

Machinery can hurt you if you are not careful. Use caution during assembly and operation of equipment.

ALWAYS:

- Read the entire manual first.

- Use common sense and be careful.
- Have enough manpower.
- Have the proper tools.
- Follow directions and illustrations.
- Check to see that all equipment meets applicable installation codes for your area.
- Have sufficient safety warnings on all equipment.

Note:

Warning labels attached to the ice sizer and drive guard should be followed. They are



TSIS-9006

Figure 2-1 Warning Label on the Ice Sizer (Safety Label 1 in Figure 2-3)

WARNING! Read this section first. Failure to carefully follow these instructions could result in permanent injury or loss of life.

shown in Figure 2-1 and Figure 2-2.

If all labels are not attached and visible or labels start to become illegible, contact Turbo Refrigerating Company immediately.

TURBO REFRIGERATING CO
1000 WEST ORMSBY AVENUE
SUITE 19
LOUISVILLE, KY 40210
PHONE: 940-387-4301
TOLL FREE 800-775-8648



ONE ON ALL ACCESS PANELS (ONE PER SIDE)

Involve Your People

Before operating equipment, have the people involved in the operating or maintenance of the equipment meet to discuss the dangers and safety aspects of the ice sizer.

- Warn them of the danger of miscommunication.
- Turn electricity off and **lock it out** when working on the ice sizer.
- Have a person trained and qualified in the operation of the equipment on duty to ensure that the electricity stays **locked out** to protect the personnel working on the equipment.

WARNINGS

- The ice sizer is an automatic machine. When in operation, the motor may

Figure 2-2 Warning Label on the Ice Sizer Protective Covers
(Safety Label 2 in Figure 2-3)

- start without warning. The motor may start even if the master control switch is in the "OFF" position. Never attempt to service the ice sizer unless all electrical power is disconnected and **locked out**.
- The ice discharge inlet and outlet has a warning label (refer to Figure 2-1). Field installation must ensure that a cover or guard (not supplied by Turbo) is in place on the ice discharge inlet and outlet before operating to prevent entry into the screw conveyor.
- Pull disconnect and **lock out** all electrical service before removing any guards, access panels, and/or covers.
- Never operate the unit without all guards, access panels, and covers in place and securely fastened.
- Figure 2-3 shows the location of the safety labels furnished with the ice sizer. If they are not located on the ice sizer as shown, you must contact Turbo immediately (address and phone number located on the first page of this section).

WARNING! Read this section first. Failure to carefully follow these instructions could result in permanent injury or loss of life.

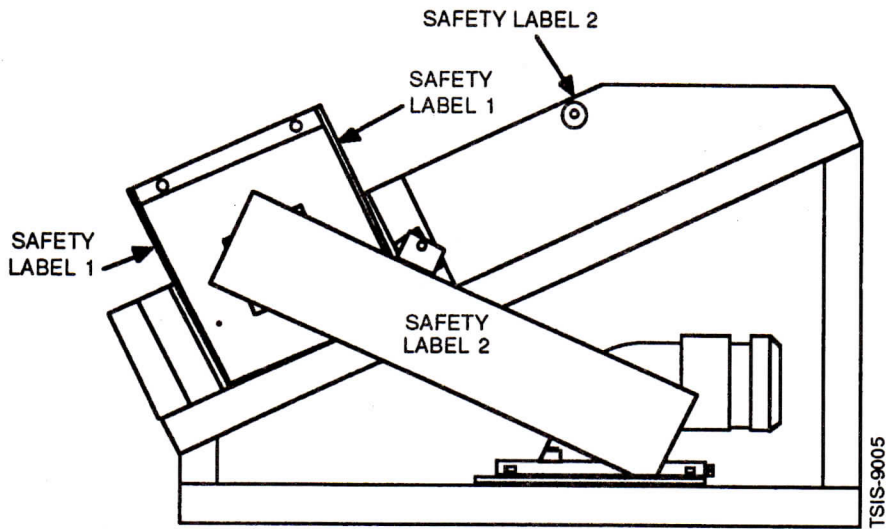

SAFETY LABEL 1: DANGER (DETAILED IN FIGURE 2-1)
 SAFETY LABEL 2: CAUTION (DETAILED IN FIGURE 2-2)

Figure 2-3 Location of Safety Labels



TWO ON END OF BELT PULLEY GUARD

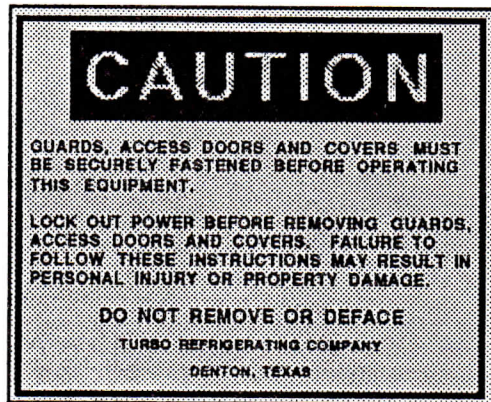

ONE ON END OF BELT PULLEY GUARD

Figure 2-4 Warning Labels on the Screw Conveyor

WARNING! Read this section first. Failure to carefully follow these instructions could result in permanent injury or loss of life.

- Always wear eye protection when cleaning the system.
 - Use only recommended ice machine cleaners. Follow instructions and warnings supplied by the manufacturer of the cleaning agents.
 - Never open the control panel (supplied by others) without disconnecting and **locking out** electrical service. All electrical work should be performed by a qualified electrician.
 - When servicing the ice sizer, Turbo recommends that at least two (2) people be present at all times.
 - Although Turbo Refrigerating Company does not supply conveying equipment beyond the ice discharge opening, any conveyors used in association with the operation of Turbo equipment must be sufficiently guarded to prevent injury. Figure 2-4 shows typical warning labels supplied with screw conveyors. As indicated above, Turbo does not supply screw conveyors but recommends that you confirm the presence of these or similar labels on the screw conveyors (supplied by others). Also attached for your use are screw conveyor manufacturer's and OSHA guidelines and standards for these devices.
- Note:**
Conveyor manufacturer's instructions and warnings are on page 13.
- If an outside contractor is required to install or service your ice sizer, require him to furnish you with a certificate of insurance before performing any work on your equipment. Turbo also recommends that the person hiring a contractor to perform work be satisfied with their experience and competence.

If you have questions, call Turbo Refrigerating Company at:

**PHONE: 940-387-4301
TOLL FREE: 800-775-8648**

WARNING! Read this section first. Failure to carefully follow these instructions could result in permanent injury or loss of life.

Conveyor Manufacturer's Instructions and Warnings

Turbo Refrigerating Company does not install conveyors, consequently it is the responsibility of the contractor, installer, owner, and user to install, maintain, and operate the conveyor, components, and assemblies in such a manner as to comply with the Williams-Steiger Occupational Safety and Health Act and with all state and local laws and ordinances and the American National Standard Institute (ANSI) safety code.

In order to avoid an unsafe or hazardous condition, the assemblies or parts must be installed and operated in accordance with the following minimum provisions.

1. Conveyors shall not be operated unless all covers and/or guards for the conveyor and drive unit are in place. If the conveyor is to be opened for inspection, cleaning, maintenance, or observation, the electric power to the motor driving the conveyor must be **locked out** in such a manner that the conveyor cannot be restarted by anyone (however remote from the area) until conveyor cover or guards and drive guards have been properly replaced.
2. If the conveyor must have an open housing as a condition of its use and application, the entire conveyor is then to be guarded by a railing or fence in accordance with ANSI standard B20.1-1976, with special attention given to section 6.12.
3. Feed openings for shovel, front loaders or other manual or mechanical equipment shall be constructed in such a way that the conveyor opening is covered by a grating. If the nature of the material is such that a grating cannot be used, then the exposed section of the conveyor is to be guarded by a railing or fence and there shall be a warning sign posted.
4. Do not attempt any maintenance or repairs of the conveyor until power has been **locked out**.
5. Always operate conveyor in accordance with these instructions and those contained on the caution labels affixed to the equipment.
6. Do not place hands or feet in the conveyor.
7. Never walk on conveyor covers, grating, or guards.
8. Do not use conveyor for any purpose other than that for which it was intended.
9. Do not poke or prod material into the conveyor with a bar or stick inserted through the openings.
10. Keep area around conveyor or drive and control station free of debris and obstacles.
11. Always regulate the feeding of material into the unit at a uniform and continuous rate.
12. Do not attempt to clear a jammed conveyor until power has been **locked out**.
13. Do not attempt field modification of conveyor or components.

Turbo Refrigerating Company insists that disconnecting and **locking out** the power to the motor driving the unit provides the only real protection against injury. Other devices should not be used as a substitute for **locking out** the power prior to removing guards or covers. We caution that use of secondary devices may cause employees to develop a false sense of security and fail to **lock out** power before removing covers or guards. This could result in a serious injury should the secondary device fail or malfunction.

WARNING! Read this section first. Failure to carefully follow these instructions could result in permanent injury or loss of life.

There are many kinds of electrical devices for interlocking of conveyors and conveyor systems such that if one conveyor in a system or process is stopped, other equipment feeding it, or following it can also be automatically stopped.

Electrical controls, machinery guards, railings, walkways, arrangement of installation, training of personnel, etc. are necessary ingredients for a safe working place. It is the responsibility of the contractor, installer, owner, and user to supplement the materials and services furnished with these necessary items to make the conveyor installation comply with the law and accepted standards.

Conveyor inlet and discharge openings are designed to connect to other equipment or machinery so that the flow of material into and out of the conveyor is completely enclosed.

WARNING! Read this section first. Failure to carefully follow these instructions could result in permanent injury or loss of life.

Safety Lockout Procedure Effective November 1, 1989

I. Purpose

The purpose of this procedure is to prevent injury and/or death to personnel by requiring that certain precautions be taken before servicing or repairing equipment. It has been developed and implemented so as to comply with 29 CFR 1910.147, of the Occupational Safety and Health Act, as amended.

These precautions include:

1. Shutting off and locking out electrical power.
2. Releasing pressure in pneumatic and hydraulic systems.
3. Effectively isolating those portions of equipment and machinery that are energy intensive and are being serviced or maintained.

II. Scope

This procedure includes those employees whose duties require them to do maintenance work on power-driven equipment. It covers the servicing or maintenance of machines or equipment in which the unexpected energization, start-up or release of stored energy could cause injury.

III. Supervisory Responsibility

It is the responsibility of all supervisors having contact with such operations to:

- A. Instruct all affected employees as to the content of this program.
- B. Ensure compliance with this procedure.

IV. Safety Locks

Safety locks and keys will be issued to designated employees. Locks and keys must be returned to the plant manager when an employee transfers to another assignment or terminates his employment. Safety and supervisory personnel shall have access to master keys for protective locks, and under certain controlled conditions, be available to assist in the removal of safety locks.

Safety locks are painted yellow for electricians and red for maintenance personnel. These locks are to be used only for locking out machinery, tooling, and equipment described in this procedure.

V. Safety Department Responsibility

It is the responsibility of the Safety Coordinator to inspect the plant on a periodic basis to ensure compliance with this

procedure. If it is determined that this procedure is not being complied with, immediate corrective action will be initiated. Wherever possible, such action will be taken in conjunction with the first-line supervisor; however, higher level management personnel will be involved if the violation is of a serious or repetitive nature.

VI. Rules and Regulations

The following rules and regulations have been established and are mandated:

A. Any electrician or maintenance person whose duties require that he or others be exposed to the hazards of electrical shock or moving equipment, must perform those duties in a safe and uncompromising manner. The following steps outline such precautions:

1. The employee must understand the equipment with which he is working and its hazards.
2. When working with electrical equipment where the accidental starting of such equipment or release of stored energy would create a hazard, the employee must turn off all power to the unit or use energy isolating devices and ap-

WARNING! Read this section first. Failure to carefully follow these instructions could result in permanent injury or loss of life.

ply his personal lock, and have the supervisor of that area apply his personal lock. At all times when maintenance is being performed on our equipment, that equipment will have 2 locks on it, one by the person performing the maintenance plus the one of the supervisor.

3. In instances where multiple circuits are in a circuit breaker box, an attaching mechanism will be placed on the outside of the box to allow that box to be locked out and prevent the door from being opened.

B. Each employee who performs the duties prescribed above will be provided with an individual safety lock and one key. If more than one employee is assigned to a task, each employee is required to place his own lock and tag so the controls cannot be operated, even though another person may have completed his own task, and remove his own lock.

C. If the equipment controls are so located that only one lock can be accommodated, a special attachment that accommodates several locks must be used. This attachment will be issued to all designated employees.

D. Should an employee be required to work on another piece of equipment and need to leave his lock on the present equipment, another lock must be obtained from the plant manager.

E. Should it be necessary to operate a piece of equipment which is locked out, every effort should be made by supervision to locate the employee whose lock is on the equipment. If that employee cannot be located, the supervisor may obtain a master key for the lock. The supervisor must personally assure himself that it is safe to remove the lock. The lock should then be returned to the proper employee.

This procedure must be used with extreme caution and good judgement.

There is danger that the employee involved will return thinking that the machine is still locked out, when it has actually been turned back on.

F. If a machine is locked out and it is necessary to leave the area, recheck the lock upon returning to make sure that the machine is still locked out. While supervision will make every attempt to avoid the removal of locks, there may be situations when it must be done. This recheck is for your protection.

G. It is sometimes necessary to operate equipment for purposes of testing or making adjustments prior to the actual completion of the work. It is recognized that electricians must work on live circuits from time to time, particularly when trouble-shooting, but extreme caution must be used under these circumstances. Never work alone when changing live wiring.

VII. Outside Contractors

Whenever outside servicing personnel are to be engaged in activities covered by the scope and application of this lockout and tag procedure, such personnel are to be informed of this procedure by the person responsible for their work activity and are to direct them to follow its requirements. Failure to do so shall require that they do not be permitted to continue working in the plant.

VIII. Failure To Follow Procedures

These procedures have been developed to protect employees from serious injury. It is necessary that all employees follow them. Those employees not complying with the provisions in this procedure will be subject to disciplinary action, up to and including discharge.



DISCONNECTING POWER & LOCK OUT

Turbo Refrigerating Company insists that **disconnecting** and **locking out** the power to the motor driving the unit provides the only real protection against injury. Other devices should not be used as a substitute for **locking out** the power prior to removing guards, covers, or other safety devices. Turbo warns that the use of secondary devices may cause employees to develop a false sense of security and fail to **lock out** power before removing guards, covers, or other safety devices. This could result in a serious injury should the secondary device fail or malfunction.

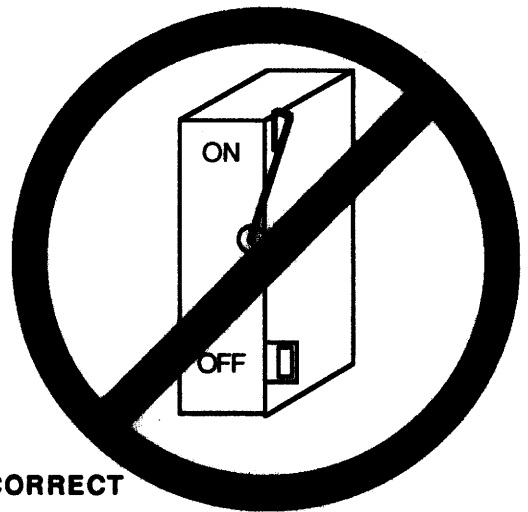

INCORRECT

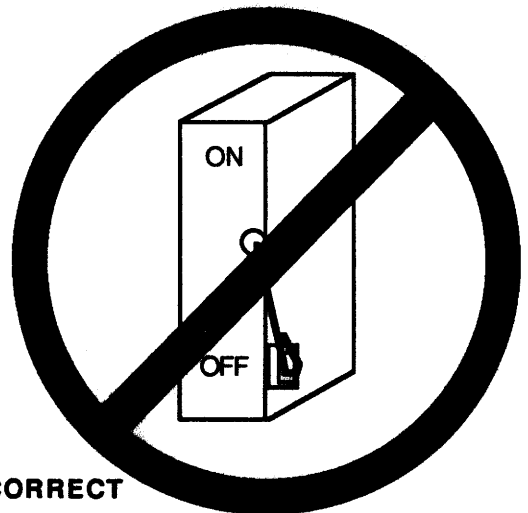

INCORRECT

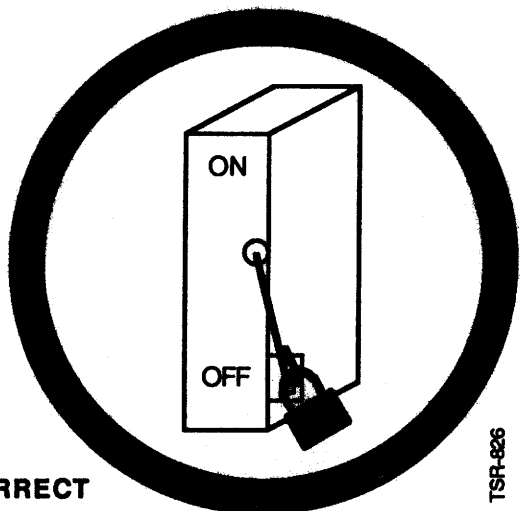

CORRECT

Read Safety Section before this section. Failure to carefully follow these instructions could result in permanent injury or loss of life.



INSTALLATION REQUIREMENTS



The Turbo ice sizer consists of a housing mounted on an inclined frame to allow ice to flow in at the top and out of the bottom by gravity. Included in the ice sizer is the three-phase sizer mechanism drive motor, the sizer mechanism, a metering flap, and an ice overfeed cut-out switch.

charged through the bottom into a screw conveyor or a belt.

An inlet and outlet transition (by others) is required on the sizer to:

1. Convey ice from the feed system into the ice sizer.
2. Limit access into the ice sizer inlet and outlet openings.
3. Enclose the outlet opening of the feed device to the ice sizer.

These transitions or covers are field fabricated and installed by others to fit the requirements of each installation. Refer to Figure 3-2 for framing dimensions for the inlet and outlet transitions.

Installation

The ice sizer is designed to be fed into the top inlet opening by any standard screw conveyor (auger) or conveyor belt (not provided by Turbo). Refer to Figure 3-1. Ice is dis-

WARNING

Failure to enclose the inlet or outlet openings could result in serious injury due to contact with rotating parts inside the sizer. Failure to carefully follow these instructions could result in permanent injury or loss of life.

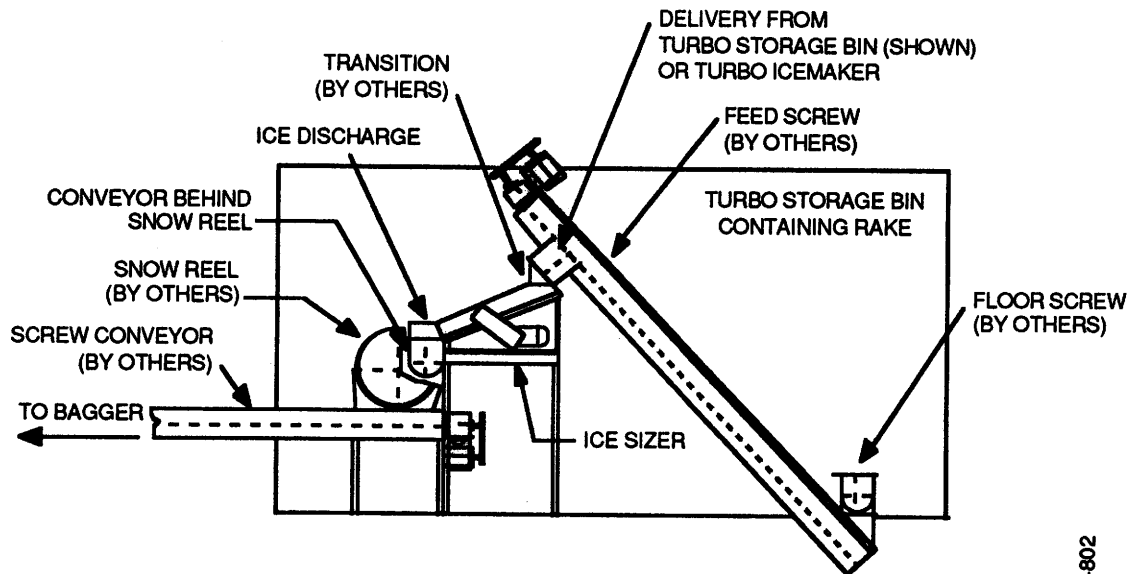

ELEVATION VIEW

Figure 3-1 Ice Feed

TSIS-802

Read Safety Section before this section. Failure to carefully follow these instructions could result in permanent injury or loss of life.

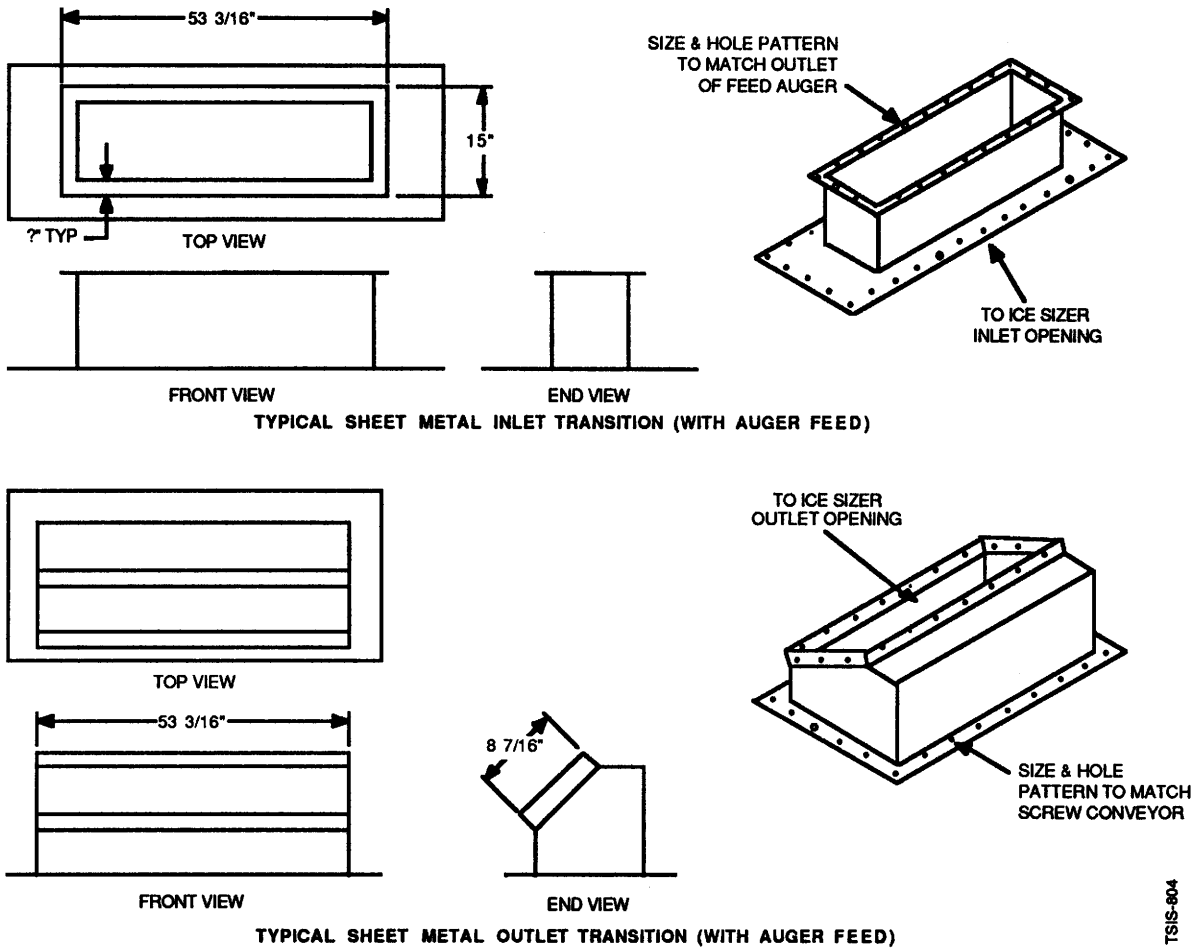

Figure 3-2 Framing Dimensions for Inlet and Outlet Transitions

The ice sizer is bolted to the floor or to a stand above the screw or snow reel in the delivery or bagging system. Figure 3-3 shows a typical ice sizer configuration. Figure 3-4 shows the framing dimensions for the ice sizer base (if a stand is required).

Electrical Components

Drive Motor

A three-phase motor suitable for 230/3/60 or 460/3/60 power (other voltages and 50 cycle are available as special

orders). Connections are made at the motor terminal box. Turbo does not provide the motor starter, motor overload protection, or disconnects for the sizer.

Read Safety Section before this section. Failure to carefully follow these instructions could result in permanent injury or loss of life.

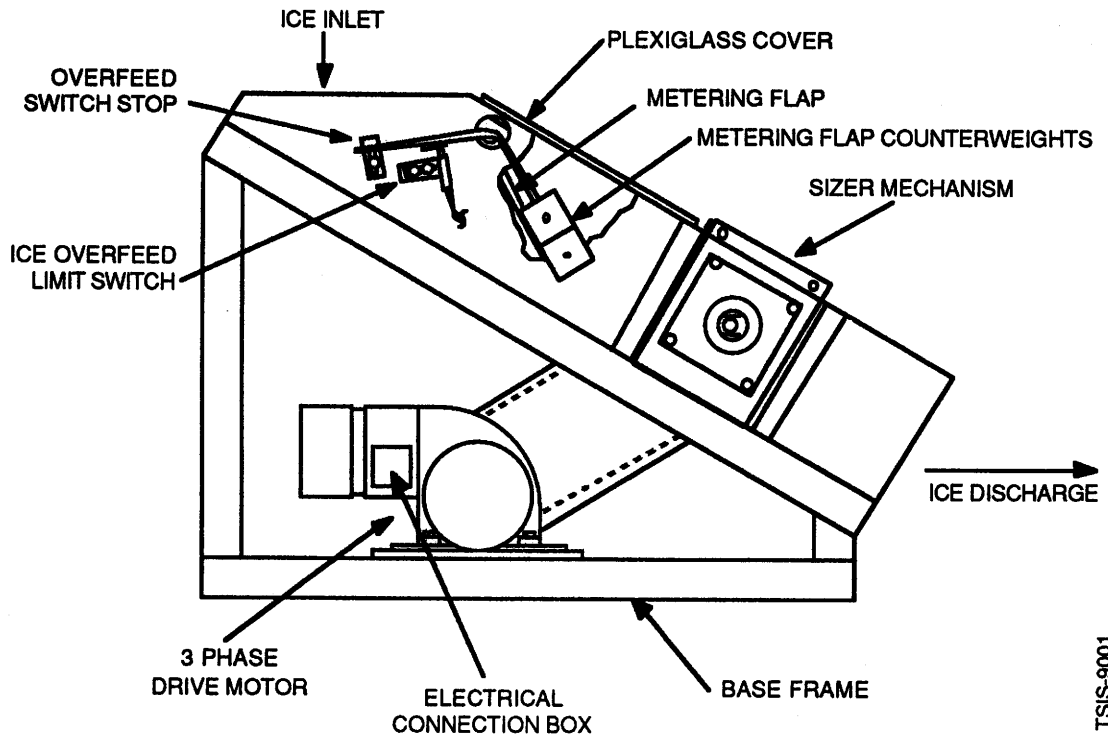

TSIS-9001

Figure 3-3 Ice Sizer Configuration

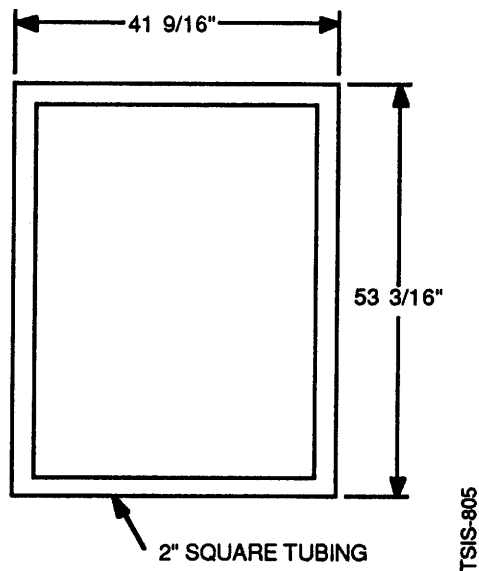

TSIS-805

Figure 3-4 Ice Sizer Base Frame Dimensions

Read Safety Section before this section. Failure to carefully follow these instructions could result in permanent injury or loss of life.

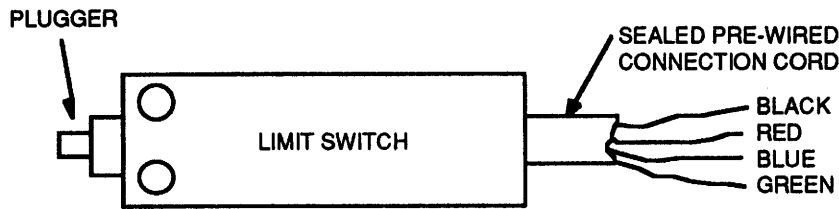

CONTACTS: 1 NC - 1 NO SPDT
 CONTACT RATING (HERMETICALLY SEALED)
 120 VOLTS 3.0 AMPS
 240 VOLTS 1.5 AMPS
 CONNECTION: PREWIRED CABLE (3' LONG)

TSIS-806

Figure 3-5 Limit Switch Specifications

Controls

An ice overfeed limit switch (Turbo part number 035-2301-01) with normally closed contacts is provided on the sizer. See Figures 3-5 and 3-6 for the limit switch specifications and wiring. The limit switch should be interlocked with the feed system to the sizer. The typical ice sizer sequence on page 21 explains the purpose of the limit switch (to be connected into the customer supplied control system).

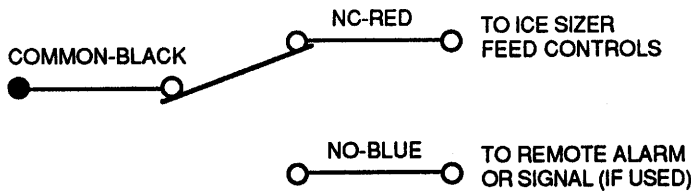

TSIS-9002

Figure 3-6 Limit Switch Wiring

Read Safety Section before this section. Failure to carefully follow these instructions could result in permanent injury or loss of life.



OPERATING INSTRUCTIONS



Introduction

The ice sizer is intended to be the last device in the ice system before the ice is bagged. The uniform sizing of the ice will ensure maximum product in the bag. Ice from the Turbo icemaker or ice generator is retained in bulk storage using a Turbo rake system until the bagging is scheduled to meet overall plant operations. When the bagging operation is started, the Turbo storage system is placed in the delivery mode and the ice is delivered to the ice sizer by means of screw or belt conveyor (not supplied by Turbo).

Typical Ice Sizer Sequence

- With normal delivery to the sizer, the limit switch contacts remain closed and the ice feed to the sizer continues.
- If the ice delivery surges and creates a feed rate the sizer cannot handle, the metering flap in the sizer inlet will rotate open. A counterweighted arm is attached to the pivot shaft of the metering flap. Excessive ice flow will cause the flap and arm assembly to rotate until it depresses the plunger on the limit switch.

- When the metering arm depresses the limit switch, the normally closed contacts open to:
 - Stop delivery of ice to the ice sizer.
 - Allow the sizer to handle the ice in the metering slide by delaying feed to the sizer for a short time (see note below).
- After the overfeed is eliminated, the metering flap will rotate to close and the limit switch contact will close to resume ice delivery.

The sized ice leaves the ice sizer and goes directly to the bagging line shaker or rotating screen to remove fines and snow. Oversize ice nuggets are taken by a return screw conveyor to the sizer.

Thus, the product in the bag is:

- free of snow
- uniform in size
- high quality.

All of the product sizing is done in the sizer. Shakers or rotating screens are recommended to further ensure only the nugget size you want gets in the bag. Nugget size can be varied by changing the thickness of the ice produced on the Turbo icemaker or ice generator. This is accomplished by a simple timer adjustment.

Note:

It may be desirable to provide a time delay in the ice delivery control circuit to allow a short delay in the resumption of ice flow to the sizer. This will ensure a positive clearing of the overfeed.

Metering Arm

The metering arm is provided with adjustable counterweights to prevent unwanted bumping of the flapper which could cause nuisance tripping of the limit switch.

As the counterweight is moved further out on the metering arm, the ice volume required to trip the limit switch increases. Conversely, as the counterweight is moved in, the volume of ice required to trip the limit switch decreases.

Final adjustment of the counterweight (to obtain the maximum feed to the sizer without jamming) is made in the field. Ice shape and size entering the sizer are among many factors affecting the counterweight adjustment. The ice sizer will handle ice up to one (1) inch thick.

Read Safety Section before this section. Failure to carefully follow these instructions could result in permanent injury or loss of life.

Read Safety Section before this section. Failure to carefully follow these instructions could result in permanent injury or loss of life.

SERVICE AND TROUBLE-SHOOTING

Clearing Ice Obstructions

If the ice flow through the sizer becomes jammed, follow these steps:

1. Shut off and lock out the three-phase power to the ice sizer drive motor.
2. Shut off the delivery of ice to the ice sizer to prevent a continuation of ice delivery while the jam is being cleared. (The limit switch will stop ice delivery to the ice sizer when the jam occurs.)
3. Remove the plexiglass cover over the ice sizer inlet.
4. Remove the ice in the metering slide.
5. Replace the plexiglass cover.
6. Turn the power to the sizer back on.

7. Start the sizer with the ice delivery off to clear any ice that was left in the sizer mechanism or slide.

8. Resume ice delivery to the sizer.

9. Observe operation to ensure that it is operating properly.

Ice Sizer Mechanism Service

The ice sizer mechanism is designed for removal as an assembly for inspection or repair.

WARNING

Caution must be exercised when handling the sizer mechanism because of the sharp edges. Failure to carefully follow these instructions could result in permanent injury or loss of life.

WARNING

The ice sizer mechanism consists of disks with sharp edges. When the plexiglass cover is removed, caution must be used to avoid contact with these sharp edges. Never operate the ice sizer without the plexiglass cover in place. Failure to carefully follow these instructions could result in permanent injury or loss of life.

Read Safety Section before this section. Failure to carefully follow these instructions could result in permanent injury or loss of life.

