

Worthington pumps for OEM services



DRESSER PUMP

DRESSER

Worthington: Industry's broadest selection of pumps for original equipment manufacturers.

Dresser offers you the widest variety of Worthington centrifugal and rotary pumps, single-stage and multi-stage, to fill your precise needs without compromise.

Our application experts fully understand the capabilities of our pumps. With their background, they can select the correct model, size, materials, impeller trim, sealing, etc. to fit your needs efficiently. The broad range of models, sizes, materials, etc. make a perfect match. All are thoroughly engineered with state-of-the-art equipment and procedures. And, all are thoroughly field-proven in thousands of applications in every variety of industry. You have assurance that you will receive the correct pump for each application.

Manufacturing is performed to the highest standards of quality assurance.

With our large inventory of units and parts, and the ability to fine-tune our production, you can be assured we can serve your continuing and recurring delivery requirements to your satisfaction.

To further serve our OEM customers, our worldwide network of qualified distributors are also available to you. They, too, carry inventories of units and parts, and have the ability to establish special stocking and delivery programs according to your schedules.

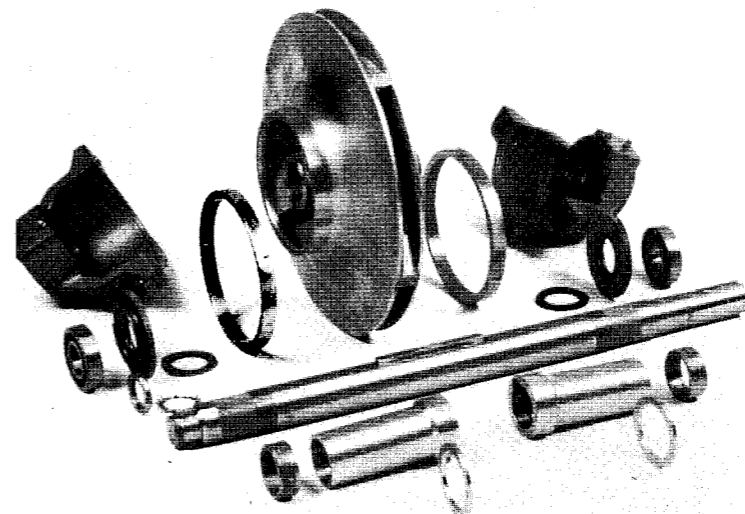
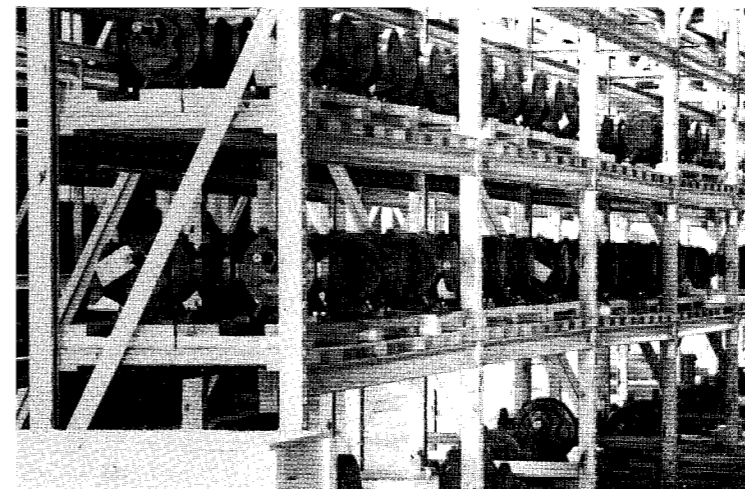
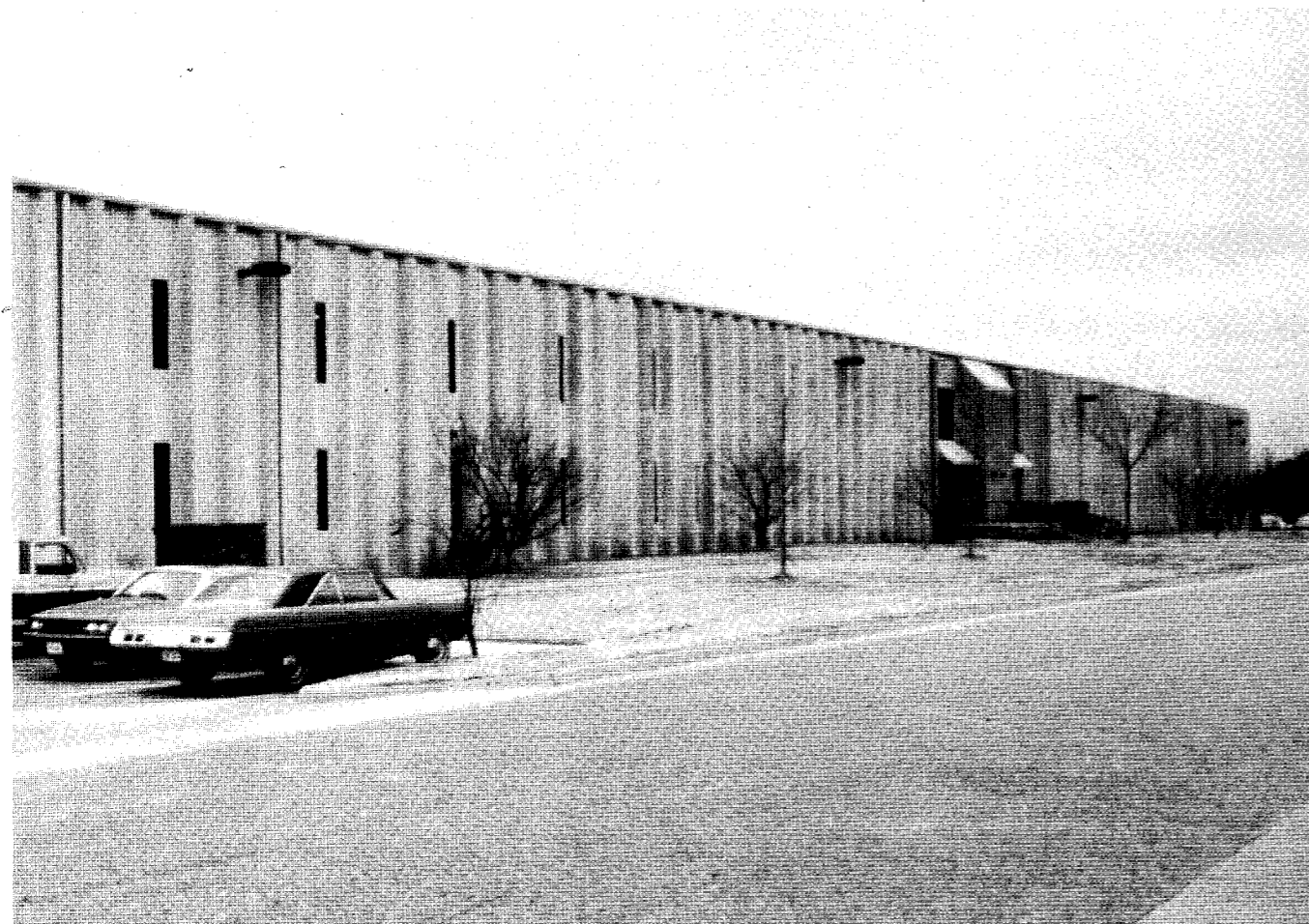

Typical Applications

OEM

- Industrial dishwashers
- Industrial laundry equipment
- Cooking oil filtration
- Package irrigation systems
- Lease automated custody transfer (LACT) units
- Heat transfer equipment
- Air scrubber systems
- Water purification & filtration
- Reverse osmosis
- High pressure washdown packages
- Main & auxiliary oil circulation packages
- Hospital & laboratory sterilization systems
- Package boiler feed systems
- Packaged cooling tower systems
- Corn processing systems
- Polystyrene extrusion systems
- Portable oil scrubber systems
- Evaporator packages
- Steam cleaner systems

Photos — Upper Left

Worthington pumps are designed utilizing the latest state-of-the-art engineering techniques that assure the utmost in product reliability. CAD (Computer Assisted Design), FEM (Finite Element Method) are but two of the tools that assist our engineers in their efforts to build efficiency and reliability into every product.

Left Center

The Chesapeake plant maintains extensive inventories of complete units and parts to assure prompt delivery to customers and distributors.

Lower Left

Chesapeake not only maintains a large inventory of parts, but also utilizes part of the plant as a 'quick' response center. This allows us to machine parts on an emergency basis to meet customers' requirements.

D-800 cast iron centrifugal pumps

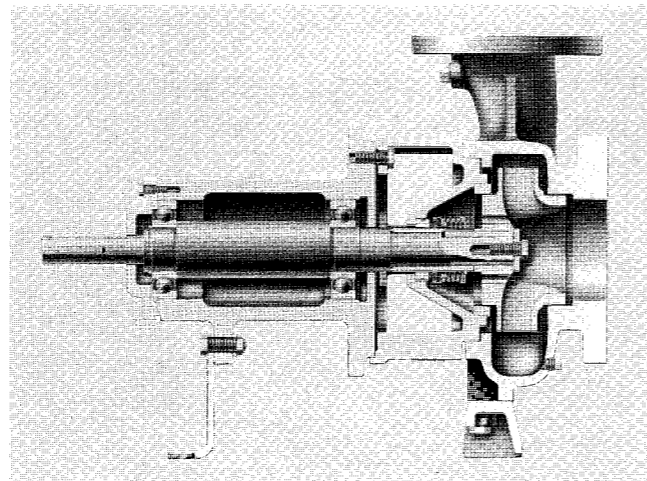
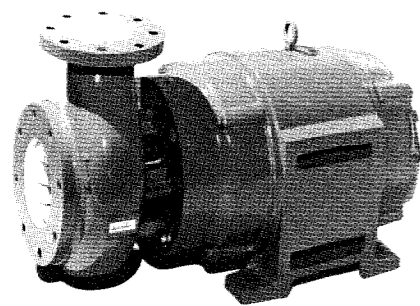

Worthington D-800 pumps available in frame mounted (D-814) or in the close coupled (D-824) (horizontal, and vertical in-line D-834) configurations, offer you 19 sizes with capacities to 1500 gpm, heads to 400 feet, in sizes from 1" through 4". Applicable for pumping water and a variety of other fluids including solvents, light oils, non-corrosive chemicals, coolants and brine, the D-800 is a line of cast iron, end suction pumps designed with a combination of features that ensure long-term reliability, high efficiency and ease of maintenance.

D-800's back pull-out design allows for easy maintenance by providing access to internal pump components, and its top centerline discharge arrangement eliminates air entrapment and bending moments on pump supports, and simplifies piping layout. Other D-800 features include:

- Capacities to 1500 gpm
- Heads to 400 feet
- Discharge sizes 1 to 4 inches
- Efficient closed impellers
- Pre-set mechanical seal

DSS-800 rolled stainless steel process pump

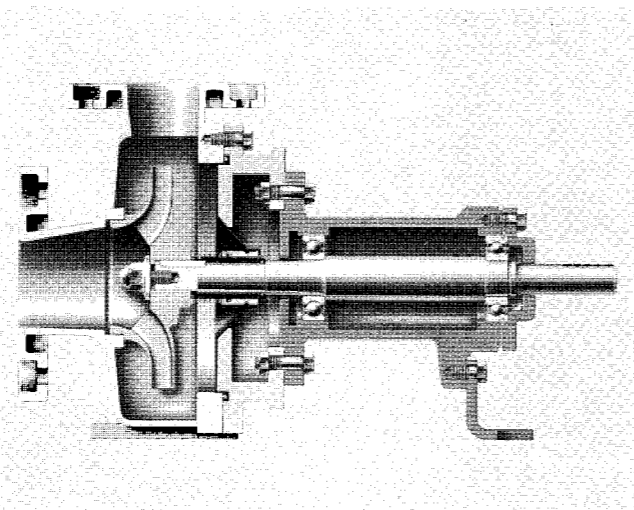
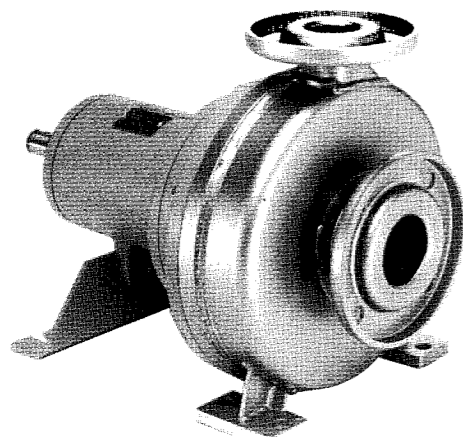

The cold rolled stainless steel used in the casing, impeller and stuffing box cover of the DSS-800 pump offer greater corrosion resistance, and is ideal for application for a wide range of process liquids. The stainless steel components are made of Cr Ni Mo which is more elastic than cast metal. The casing is approximately 7mm thick and is further compression-hardened during the deep drawing process.

- Capacities to 800 gpm
- Heads to 300 feet
- Greater corrosion resistance
- Single mechanical seals

D-500 small centrifugal pumps

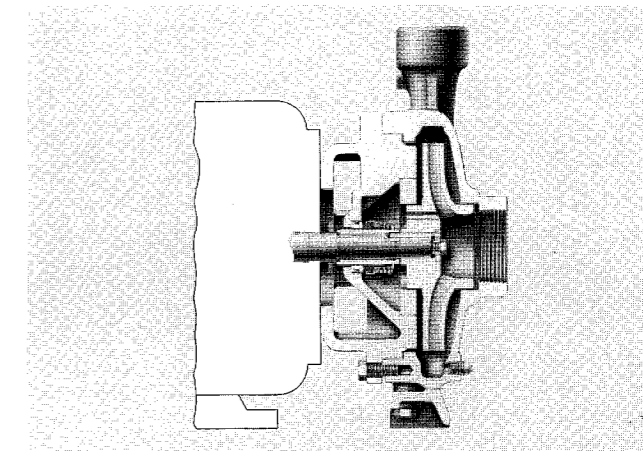
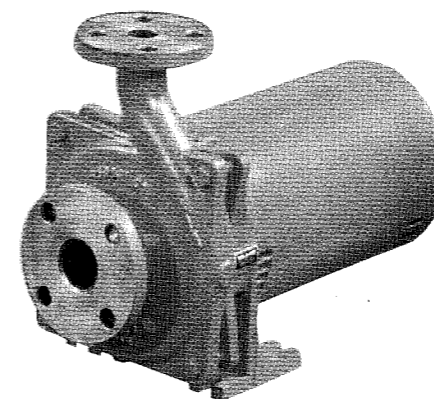

Worthington D-511/512 and D-520 end-suction pumps represent a highly standardized line, engineered to meet a broad range of commercial and industrial services. Available in close-coupled or frame-mounted models with either threaded connections (C.I.) or flanged connections (316 S.S.), the pumps are designed for durability, efficiency and economy.

Closed-impeller design offers high efficiencies across a broad range covering 1/3 to 3 HP. Closed-impellers also eliminate the need for troublesome clearance adjustments.

- Frame-mounted (D-510) and close-coupled (D-520)
- Sizes 1 to 1-1/2 inch
- Capacities to 175 gpm
- Heads to 110 feet
- Cast iron and stainless steel
- Centerline discharge - back pull-out design

D-1093/94 close-coupled pumps

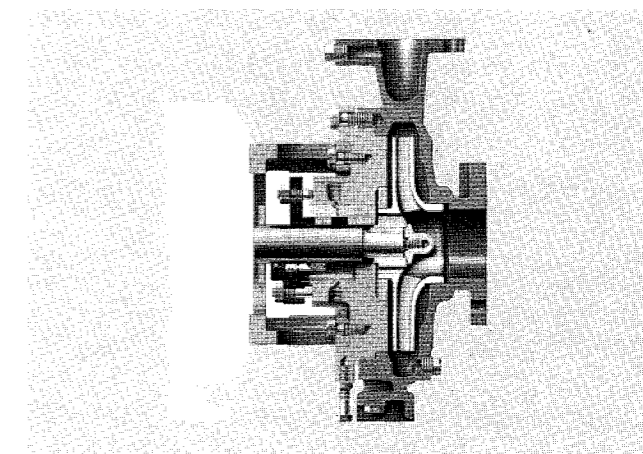
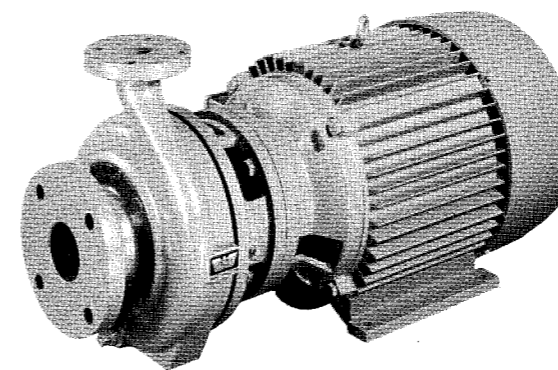

Worthington D-1093/94 pumps utilize the same casings, impellers and stuffing boxes as the Worthington D-1091. The pump is a close-coupled design, requiring only as much as half the space as the frame-mounted counterpart. It features standard ductile or modular iron construction, assuring extended life in the most difficult applications. All 316 stainless steel construction is also available. Standard NEMA motors, readily available from a variety of manufacturers are standard. The close-coupled design requires no final coupling alignment and requires no bearing frame or coupling maintenance during operation.

- Capacities to 1200 gpm
- Heads to 650 ft.
- 1 to 60 HP
- ANSI liquid end
- NEMA standard motors
- Low NPSH inducer options

DP-900 non-metallic chemical pumps

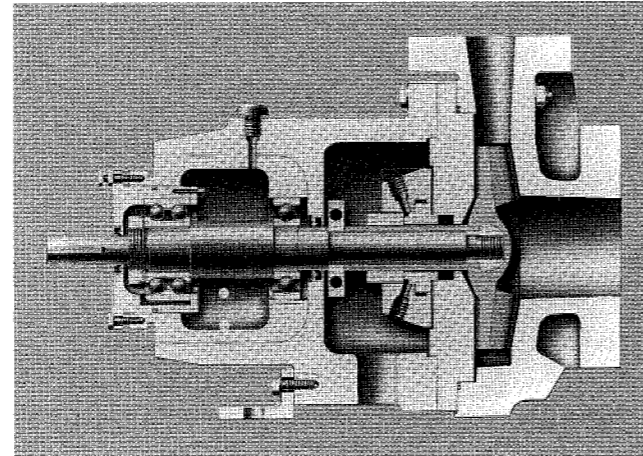
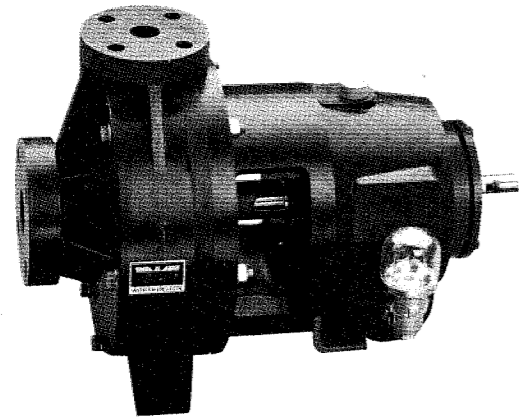

Worthington DP-900 non-metallic pumps have been designed in full accordance with ANSI B73.1 specifications. They've been engineered and constructed to withstand corrosion from a wide range of liquids. They are hydraulically efficient, impact resistant and have excellent mechanical strength.

Most DP-900 major parts are constructed of our corrosion resistant reinforced epoxy resin materials.

- Capacities to 400 gpm
- Heads to 450 feet
- Meets ANSI B73.1 specs
- Integral impeller/sleeve combination
- Wide variety of sealing options

LR/LLR centrifugal horizontal split-case pumps

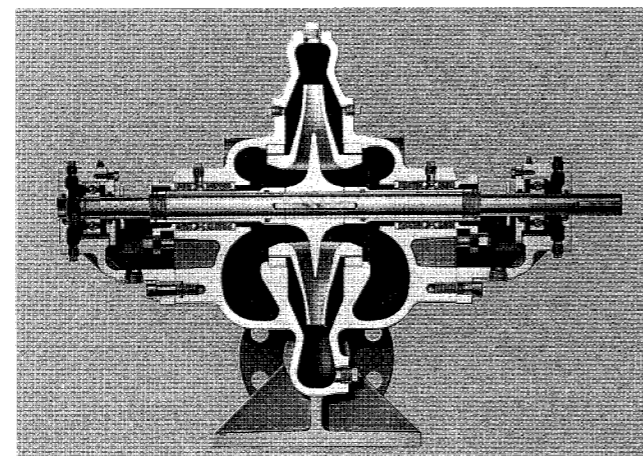
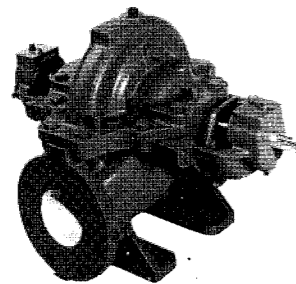

Worthington's LR line offers you 29 horizontal sizes from 1-1/2" through 10". They provide a wider range of hydraulic coverage than other typical horizontal split-case pumps and end-suction designs. Split-case pumps minimize the effects of radial load by allowing the radial thrust to be shared equally by the bearings at each end of the shaft.

The Worthington split-case line is a single-stage, double-suction impeller design. Double-suction impellers offer two advantages: reduced NPSH requirements up to 30%, and balanced axial thrust for longer bearing life.

The model LLR, single-suction, two-stage designs are available in 1-1/2-4" sizes. They feature two single-suction impellers placed back-to-back to minimize axial thrust. Radial thrust is balanced through the use of opposed volutes. Impellers are firmly secured to the shaft by use of a key and nut.

- Capacities to 19,000 gpm
- Heads to 1000 feet
- Sizes 1-1/2 to 10 inches
- Type LR - single-stage
- Type LLR - two-stage
- Closed double-suction impeller

WD low flow, high head, multi-stage ring section pumps

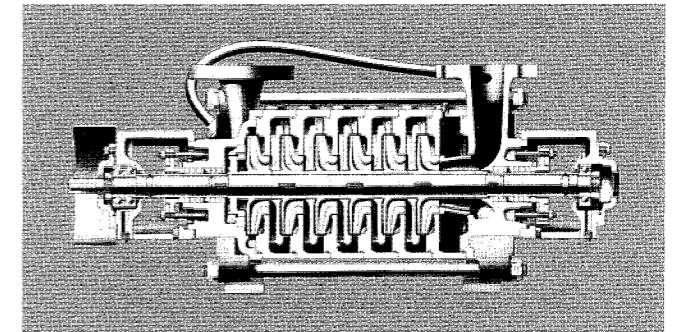
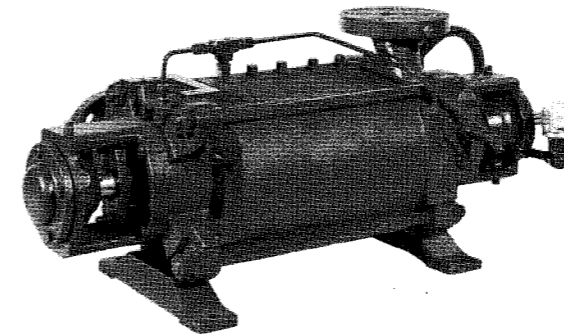

Specially developed for high-pressure, low-flow applications, Worthington's WD multi-stage ring-section pump optimizes hydraulic performance, conserves energy, minimizes the cost of the driver and reduces maintenance. A completely modular pump, it is quickly assembled from a varying number of identical stages - up to 16 as a practical limit - to closely match the requirements of each specific application.

Designed for low NPSH requirements, (lower still with its optional first-stage inducer), the WD reduces system costs by minimizing piping and suction tank requirements, and eliminating wasteful "pump and motor oversizing." The WD's design (it allows for flexible positioning of the suction

and discharge flanges independently of each other) and its compact size make it an excellent choice where space is limited and headroom at a premium, as in many OEM applications.

- Heads to 1600 feet
- Capacities to 400 gpm
- High efficiency
- Up to 16 stages
- Low NPSH - optional inducer
- Alternate nozzle positions

GA/GR heavy duty rotary pumps

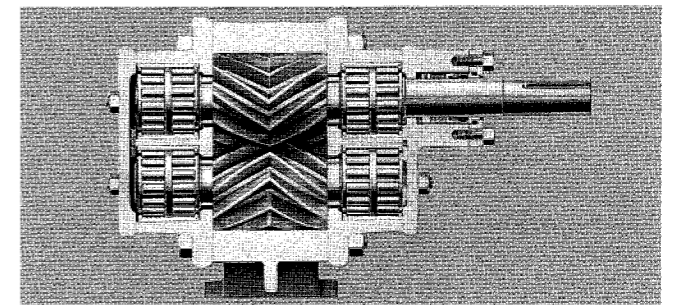
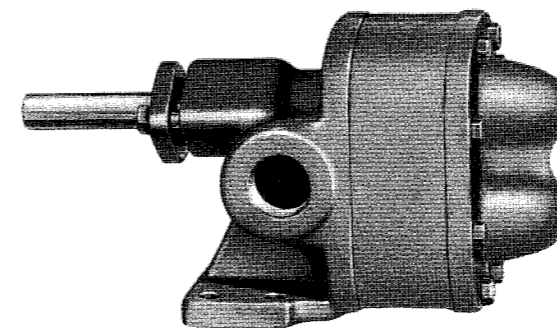

Worthington GA/GR pumps are simple external gear designs with only two moving parts to ensure long life and ease of maintenance. They are capable of handling a variety of liquids and varied conditions of service.

Worthington GA/GR pumps feature double helical or herringbone gear teeth which provide maximum face area allowing better load-carrying ability, greater strength and minimum hydraulic shock.

The smaller-capacity rotaries are often incorporated as vital parts of larger machines or pumping units: oil burners, oil filtration systems, oil transfer assemblies, lube oil consoles, machine tools, laundry equipment, packaging machinery

(including hot-melt process), diesel engines, gear reducers, pressure spray outfits, hydraulic systems, and for lube, fuel or bilge pumping on smaller marine craft.

- Pressures to 500 p.s.i.
- Capacities to 1100 gpm
- GR sizes 1-1/2 to 6 inches
- Smooth running herringbone gears
- Temperatures to: GA 450 F; GR 500 F
- GA - flange and frame-mounted, belt-drive option
- GR - direct drive

Worldwide distribution assures availability of pumps, parts and service.

An extensive network of Dresser Pump sales offices and Worthington pump distributors, located in every major trading area, is your assurance that there is a Dresser Pump, Worthington representative near you for prompt, local service when you need it.

Worthington pump distributors are factory trained specialists in pumping equipment. They can offer you expert assistance on pump application, selection, installation, operation, and maintenance.

Local availability is another benefit of selecting and using Worthington pumps. Worthington distributors carry large inventories of pumps and parts. In most cases, immediate shipment can be assured. And service is always nearby for prompt reaction to your specific needs.

You can locate the Dresser Pump sales office or Worthington distributor in your area by consulting your local telephone directory.

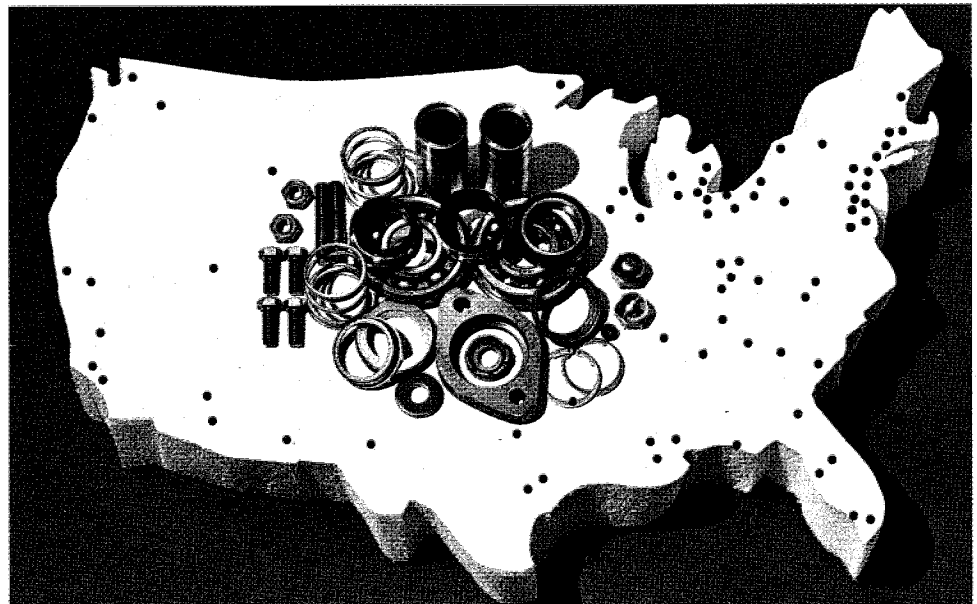
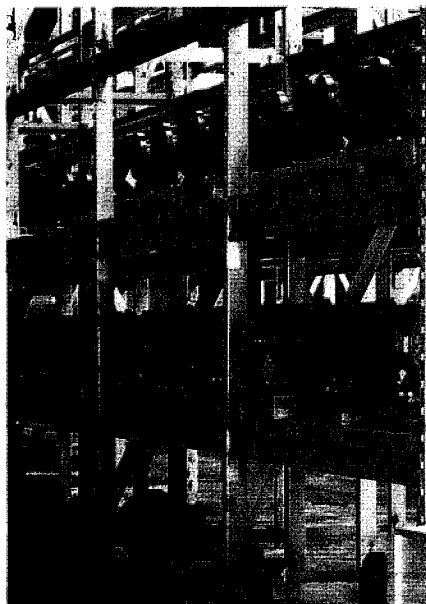

Your Local Contact Is:

Dresser Pump Division
Dresser Industries, Inc.
815 Live Oak Drive
Chesapeake, VA 23320



CAST IRON
TYPE D-520
TYPE D-511 & D-512

FEATURES

- Capacities to 175 gpm
- Heads to 110 feet
- General Service
- Cast iron construction
- Close coupled or frame mounted
- Standard Nema motors

Standardized for economy and availability.

Worthington D-511/512 and D-520 end-suction pumps in cast iron represent a highly standardized line, engineered to meet a broad range of commercial and industrial services. Available in close-coupled or frame-mounted models with threaded connections, the pumps are designed for durability, efficiency, and economy.

High efficiency.

Closed-impeller design offers high efficiencies across a broad range covering 1/3 to 3 hp. capacities to 175 gpm, and heads to 110 feet. Closed-impellers also eliminate the need for troublesome clearance adjustments.

Centerline discharge and alternate nozzle positioning.

The centerline discharge design is inherently self-venting, and minimizes the possibility of a pump becoming vapor bound. The discharge nozzle can be rotated in 90-degree increments for greater flexibility in piping arrangements. All nozzles are standard ANSI 125 lb. rated.

Easy-maintenance back-pullout design.

For easy maintenance when required, back-pullout design enables the pump rotating assembly to be removed by simply disconnecting four bolts, without disturbing the discharge or suction piping.

Standard motors for off-the-shelf availability.

The D-520 is designed for use with the NEMA/Hydraulic Institute approved standard "C" face jet pump motor. This industry-standard motor is universally available from local suppliers as a stock item.

Frame Mounted D-511/512

- Mechanical seal or packed box
- Channel steel or cast iron baseplate

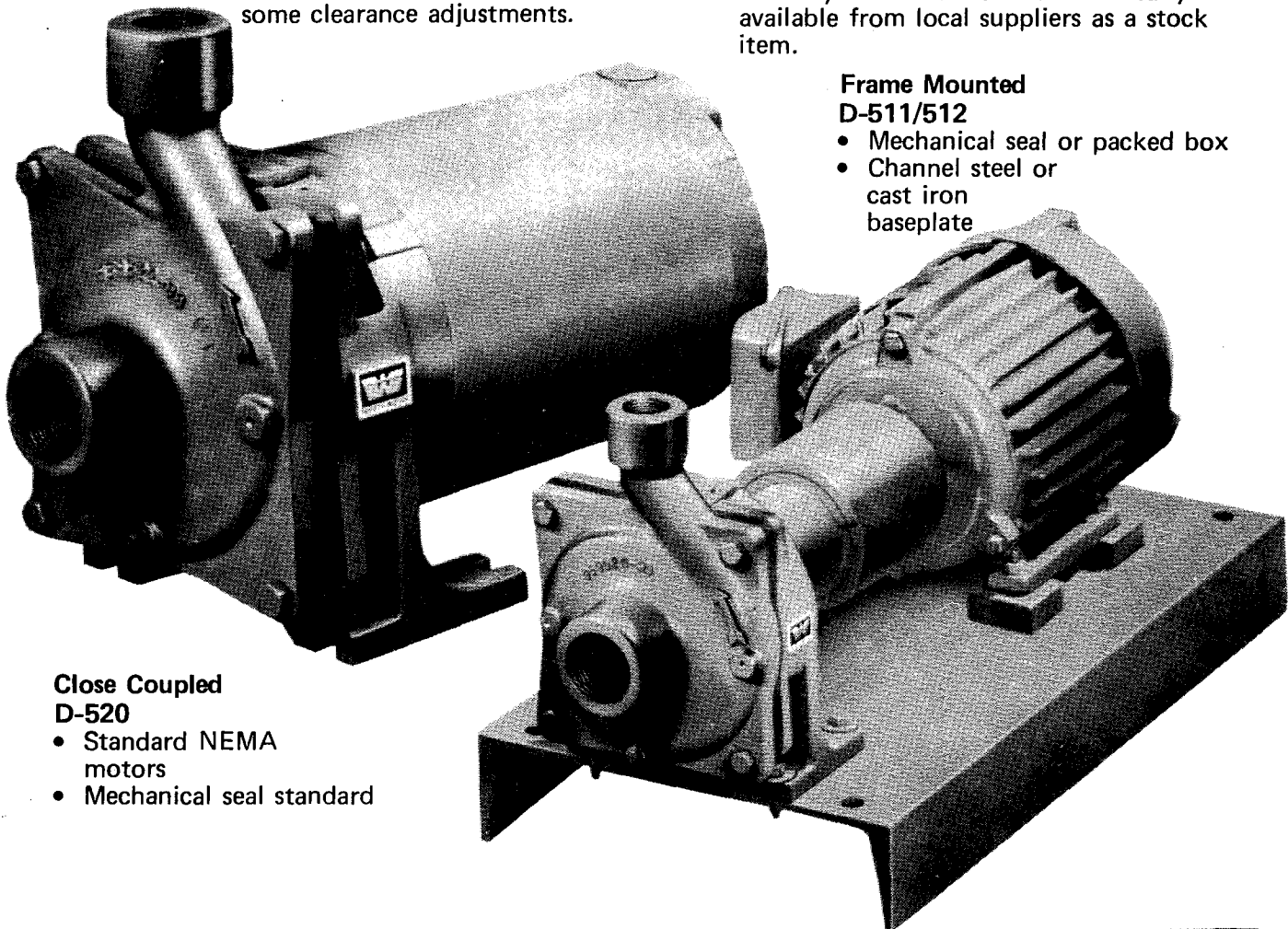

Close Coupled D-520

- Standard NEMA motors
- Mechanical seal standard

FEATURES

CAST IRON
TYPE D-520
TYPE D-511 & D-512

D-520
Close-coupled,
mechanical seal.

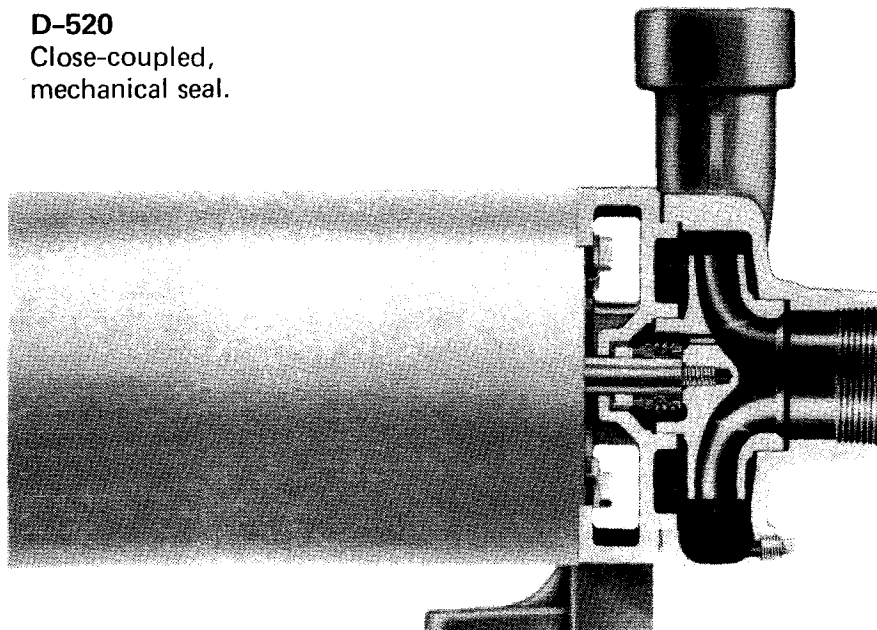

D-512
Frame-mounted,
mechanical seal.

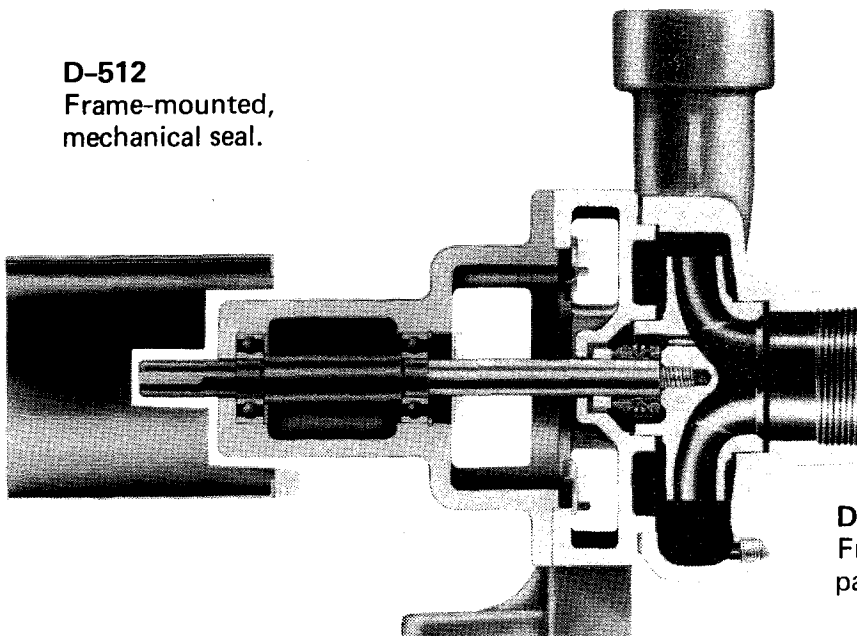

D-511
Frame-mounted,
packed stuffing box.

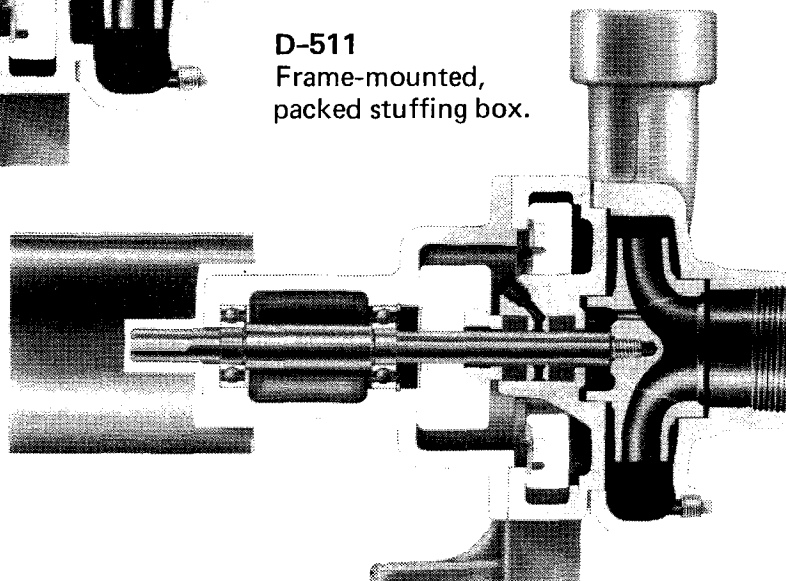

TYPE D-520
316 SS

FEATURES

- Heads to 110 feet
- Capacities to 175 gpm
- Corrosive services
- All-316 stainless steel construction
- ANSI flanged nozzles
- Standard Nema motors

Worthington D-520 end-suction close-coupled centrifugal pumps with flanged connections are designed for a wide range of commercial and industrial applications. Five sizes are available for broad coverage in the 1/3 to 3-hp range with capacities to 175 gpm and heads to 110 feet.

Corrosion resistance.

The D-520 stainless steel pump features flanged connections which avoid corrosion problems common to threaded connections.

High-efficiency closed impellers.

Worthington's D-520 features a high-efficiency, investment-diecast stainless steel closed impeller. The investment-diecast technique results in superior quality

castings. The closed-impeller design offers higher efficiency than open-impeller designs, and eliminated the need for troublesome axial shaft adjustments.

Centerline discharge and alternate nozzle positioning.

The centerline discharge design is inherently self-venting, and minimizes the possibility of a pump becoming vapor bound. The discharge nozzle can be rotated in 90-degree increments for greater flexibility in piping arrangements. All nozzles are standard ANSI 150-lb. rated flanges.

Standard motors for off-the-shelf availability.

The D-520 is designed for use with the NEMA/Hydraulic Institute approved standard "C" face jet pump motor. This industry-standard motor is universally available from local suppliers as a stock item.

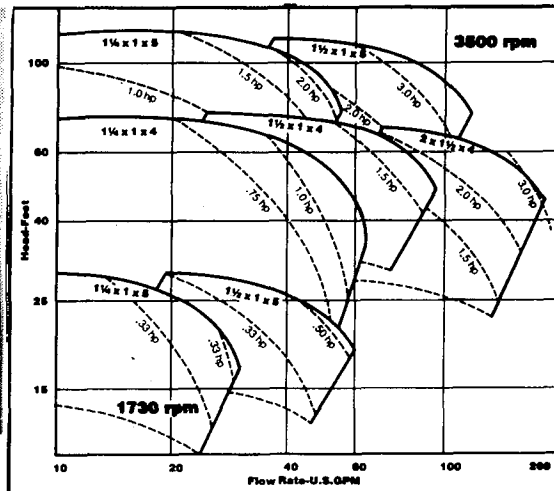
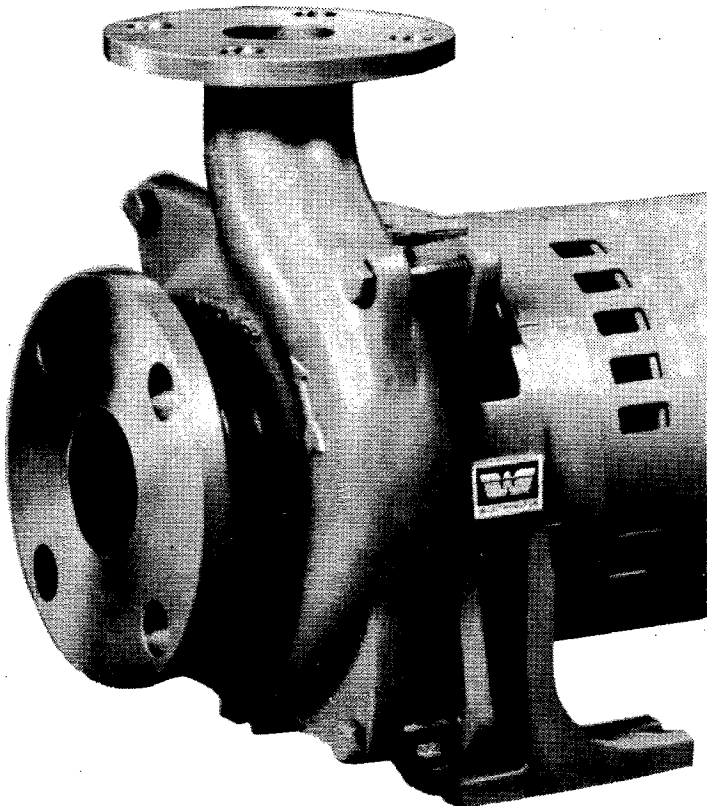

FEATURES

TYPE D-520
316 SS

Standard mechanical seals.

A positive-drive mechanical seal compatible with the pump materials is supplied as a standard on the D-520 (the standard seal is comprised of stainless steel parts and viton elastomer flexible members; other seal materials are available as options). All seals come standard with a 316 stainless steel shaft sleeve.

Easy-maintenance back-pullout design.

For easy maintenance when required, back-pullout design enables the pump rotating assembly to be removed by simply disconnecting four bolts, without disturbing the discharge or suction piping.

**Type D-520 pumps –
flanged connections**

**Materials of
construction**

Part	Material
Casing	316 Stainless Steel
Impeller	316 Stainless Steel
Stuffing Box Head	316 Stainless Steel
Mounting Bracket	Cast Iron
Casing Gasket	Red Devil - 40
Motor Shaft	416 Stainless Steel
Mechanical Seal	Carbon vs. ceramic faces, 316 stainless steel spring and metal parts, viton bellows, 316 stainless steel sleeve.

Typical applications:

- Dionized water
- Sea water
- Jucies, Wine, Beer
- Chemicals
- Solvents
- Machine oils

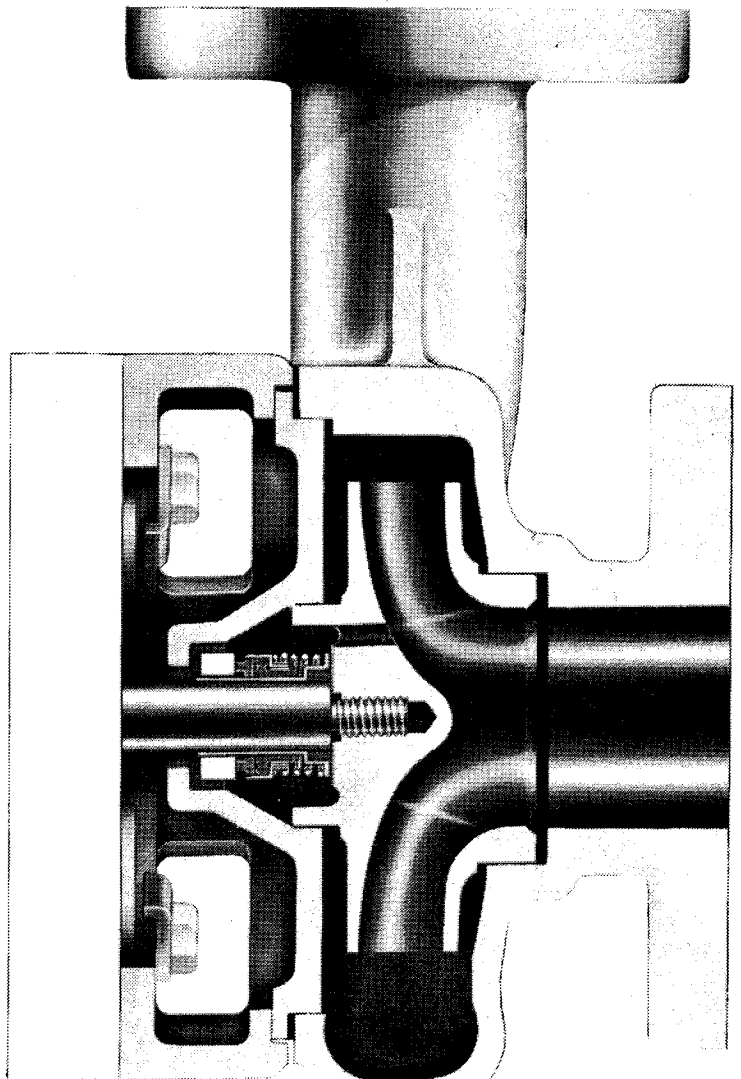

- Heads to 110 feet
- Capacities to 175 gpm, sizes to 3 hp
- Corrosive services
- All 316 stainless steel construction
- ANSI Flanged Nozzles
- Frame mounted

Worthington D-511 and D-512 end-suction frame-mounted centrifugal pumps with flanged connections are designed for a wide range of commercial and industrial applications. Five sizes allow broad coverage in capacities to 175 gpm and heads to 110 feet.

Corrosion resistance

The D-511 and D-512 in all 316 stainless steel are ideal for most corrosive services. All pumps feature flanged connections to avoid corrosion problems common to threaded connections.

High-efficiency closed Impellers

Worthington's efficiency, investment-diecast stainless steel closed impellers. The investment-diecast technique results in superior quality castings.

The closed-impeller design offers higher efficiencies than open-impeller designs, and eliminates the need for troublesome axial clearance adjustments.

Centerline discharge and alternate nozzle positioning.

The top centerline discharge design is inherently self-venting, and minimizes the possibility of a pump becoming vapor bound. The discharge nozzle can be rotated in 90 degree increments to allow greater flexibility in piping arrangements. All nozzles are standard ANSI 150 lb. rated flanges.

Easy-maintenance back-pullout design

For easy maintenance when required, back-pullout design enables the pump rotating assembly to be removed by simply disconnecting four bolts, without disturbing the discharge or suction piping.

Variety of sealing options

A choice of sealing options assures a perfect match for a wide variety of pumping applications. The D-511 is constructed with a convertible stuffing box permitting the use of either packing or a chemical-type mechanical seal for more critical services. The D-511 with a packed box is equipped with a split gland for ease of packing maintenance. The D-511 can also be supplied with a chemical-type mechanical seal.

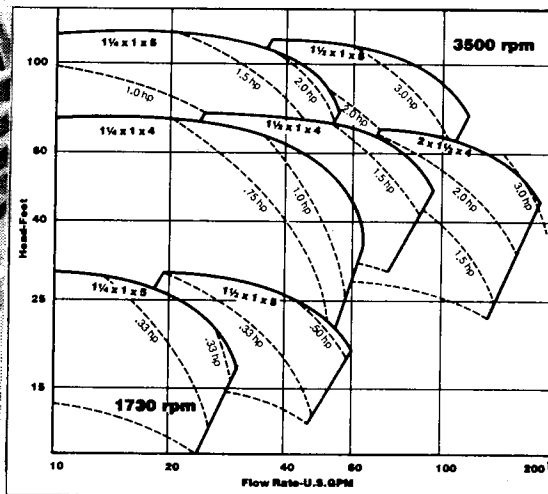
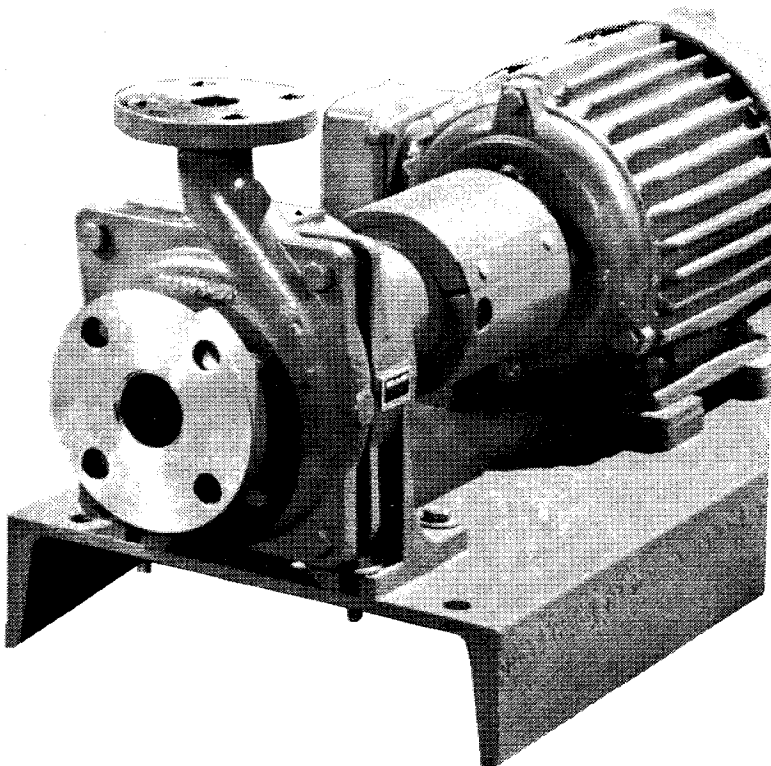

FEATURES

TYPE D511-D512

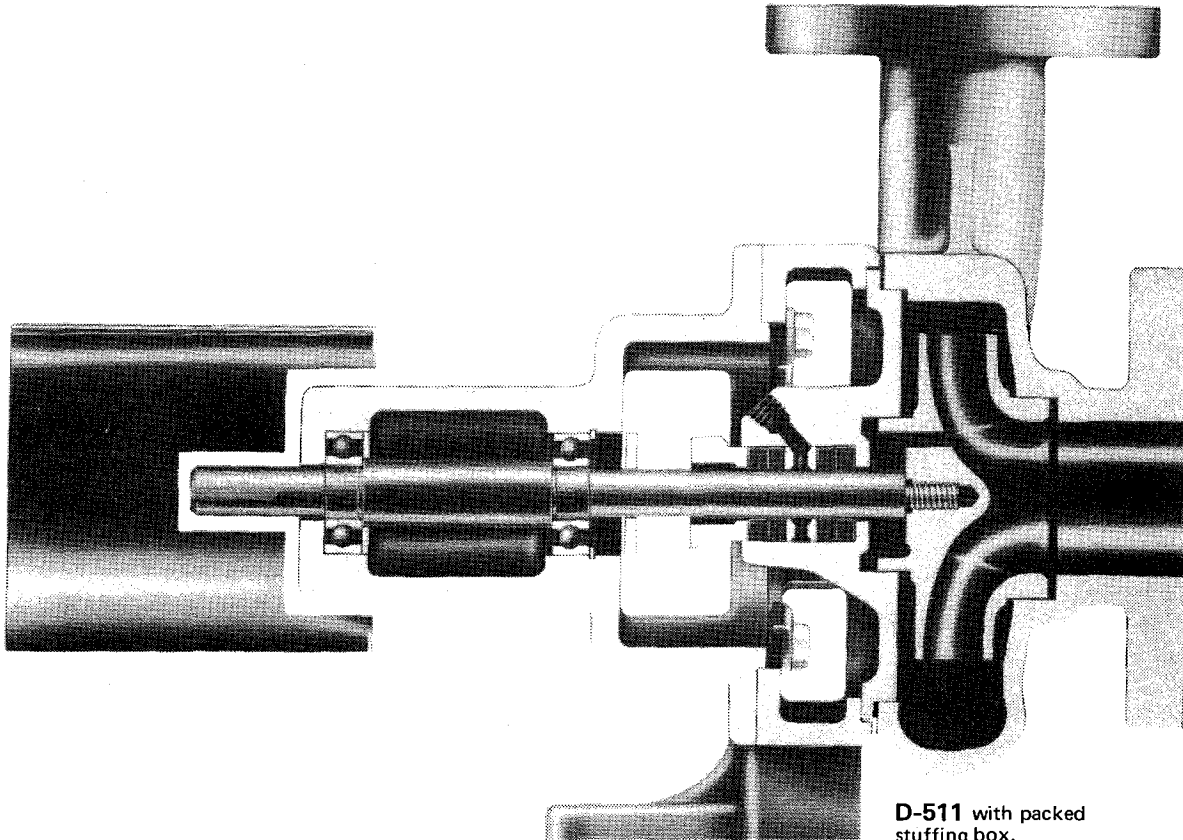

Materials of construction

Part	SS D-511	SS D-512
Casing	316 Stainless Steel	316 Stainless Steel
Impeller	316 Stainless Steel	316 Stainless Steel
Stuffing Box Head	316 Stainless Steel	316 Stainless Steel
Mounting Bracket	Cast Iron	Cast Iron
Casing Gasket	Red Devil - 40	Red Devil - 40
Shaft	316 Stainless Steel	416 Stainless Steel
Bearing Frame	Cast Iron	Cast Iron
Mechanical Seal (D-512)	Carbon vs. ceramic faces, 316 Stainless Steel spring and metal parts, viton bellows 316 Stainless Steel sleeve	
Packing (D-511)	Tfe Impr.	Not available
Split Gland (D-511)	316 Stainless Steel	Not available
Bearings	Sealed for life	Sealed for life

Parts availability

Worthington's franchised distributors are located throughout the country and have a complete stock of units and parts. They are supported by Worthington's extensive stocks of subassemblies and parts from which complete units can be

built to meet your specific needs. These distributors are geared for immediate service and fast delivery to any part of the U.S. Refer to your Yellow Pages for the nearest Worthington distributor.

Worthington D-Line ANSI Pumps

Designed to meet ANSI B73.1 and B73.2

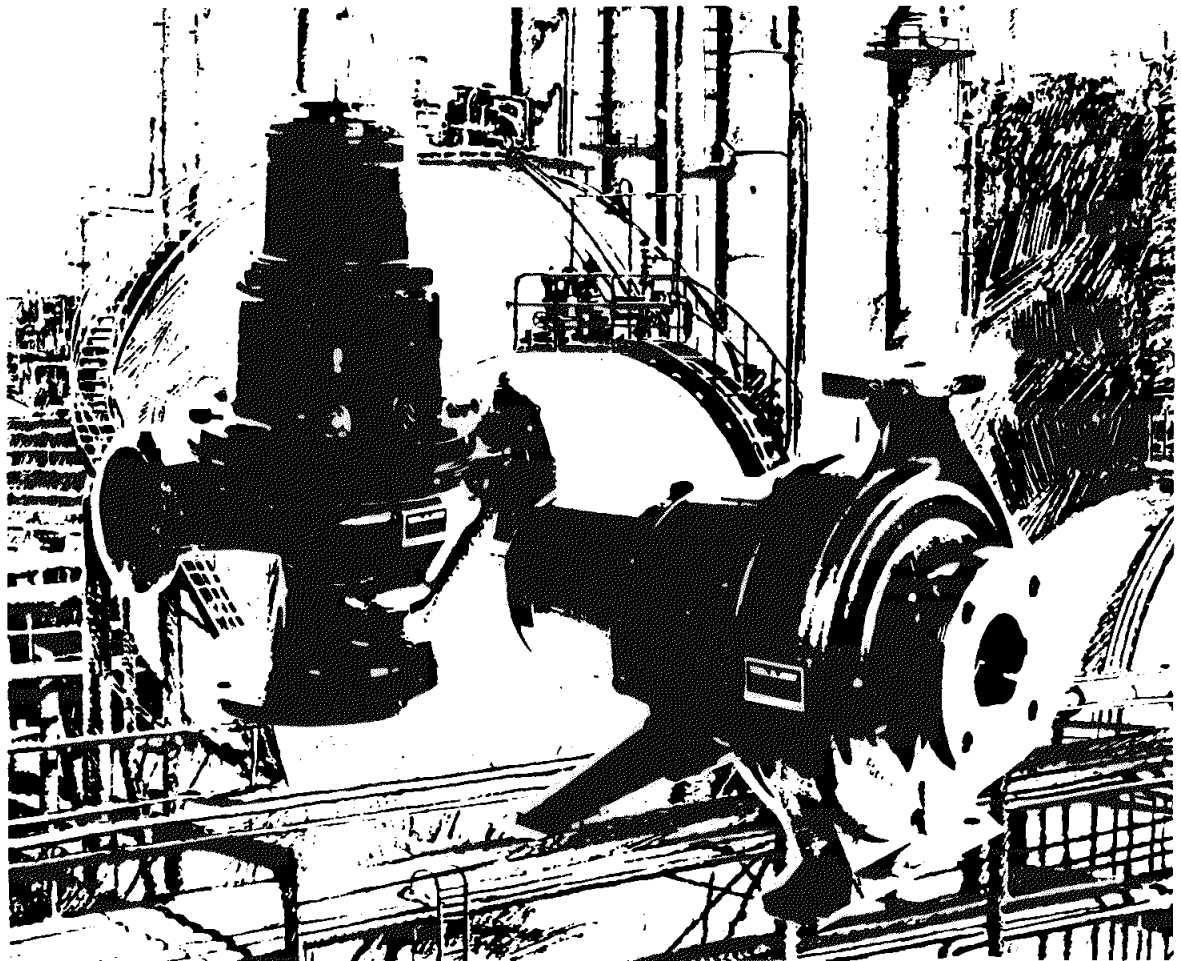

The most efficient ANSI pump line
over the broad range
of operating conditions.

A modular family of pumps to meet 90% of all process services.

Worthington D-1000 (horizontal) and D-1160 (vertical in-line) pumps are designed to meet all ANSI B73.1 and B73.2 specifications. In addition, they are part of the world's most comprehensive line of pumps, applicable to more than 90% of all end suction centrifugal process services. Like all D-Line pumps,

they are designed around a single, basic hydraulic and mechanical design concept which assures you of the greatest efficiencies across the broad range of operating conditions, the greatest application flexibility, and superior interchangeability.

Maximum interchangeability means inventory savings.

D-Line was conceived as a comprehensive pump line covering a wide range of pump applications, from general cold water service to highly corrosive high-temperature, high-pressure process applications. From the beginning, interchangeability of parts has been a design objective. As a result, the D-Line is built in "modules," allowing for the selection of a wide variety of casing configurations and materials which can be mounted in a number of arrangements, and with dozens

of options to suit your particular needs. This revolutionary concept means that you can benefit from parts interchangeability among many different types of pumps at your plant (Figure 1). In practical terms, that means substantially reduced inventory for major pump components. Within specific lines, such as the ANSI D-1000 and D-1160, interchangeability is even more extensive, and the potential inventory savings even greater (Figure 2).

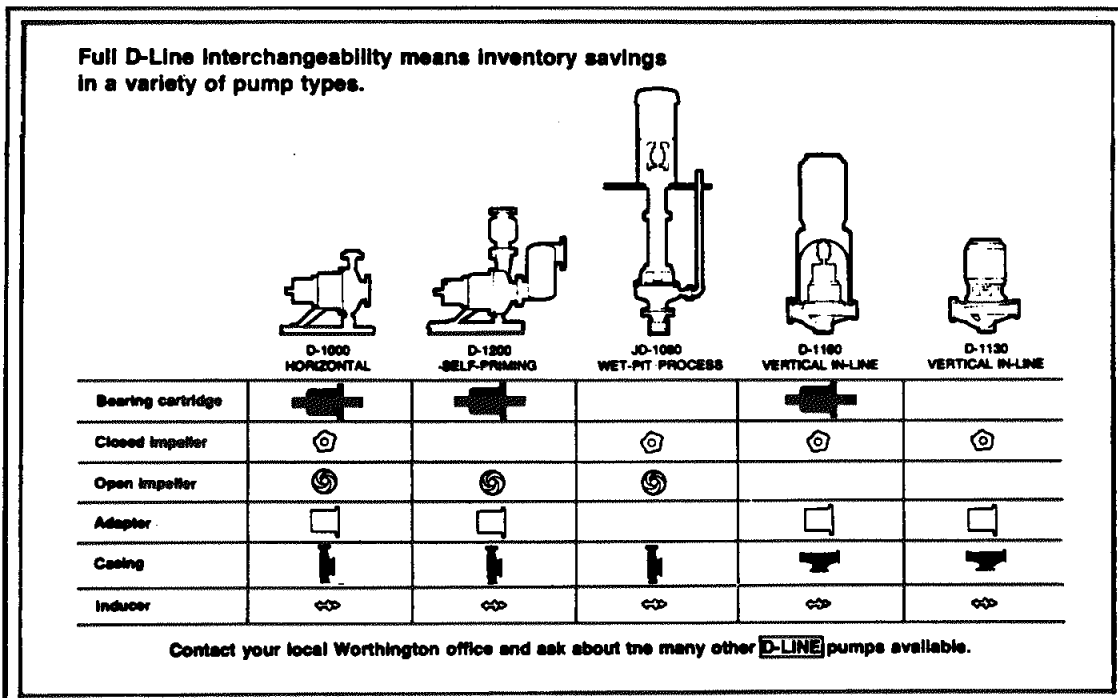

Figure 1 — Full D-Line interchangeability between a variety of pump types results in inventory savings.

Worthington D-Line pumps are protected by the following U.S. Patents: 3,841,791 - 3,891,345 - 3,910,715

D-LINE ANSI

D-Line ANSI Pumps

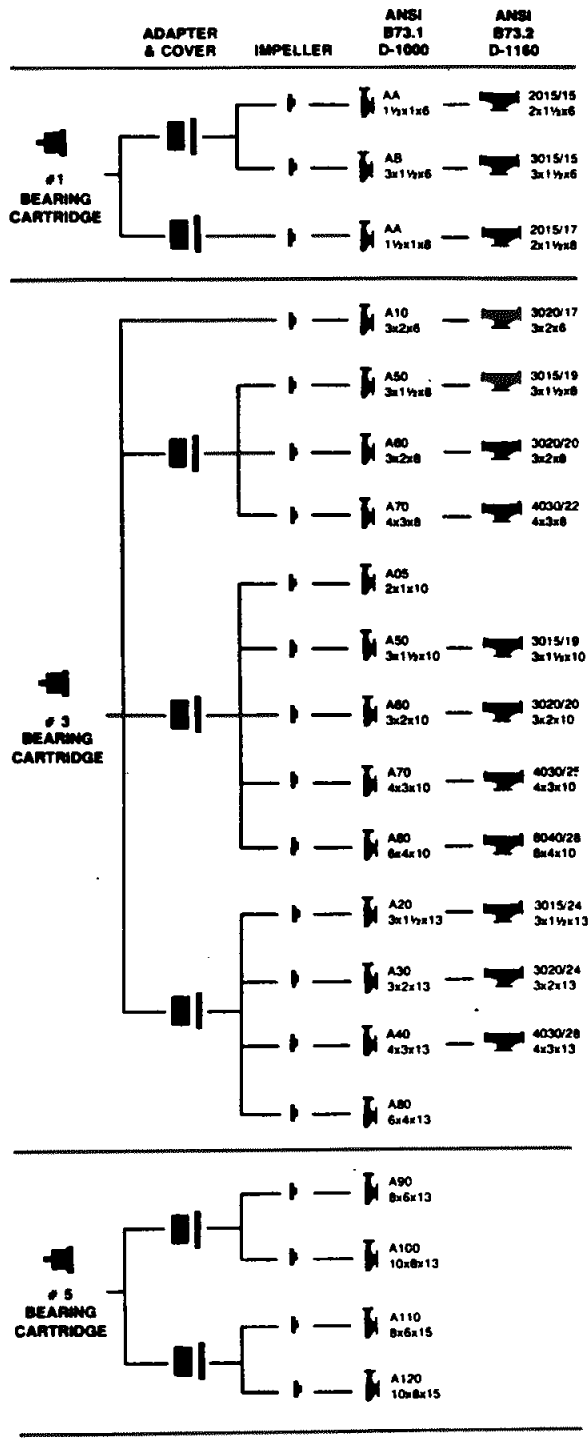

Figure 2 — No other ANSI pump line matches D-Line's parts interchangeability. All D-Line ANSI models, both vertical and horizontal, are designed around just three bearing cartridges. For example, one bearing cartridge could cover as many as 24 ANSI sizes.

Greater efficiency means substantial energy savings.

One of the most effective ways to cut energy costs is to reduce horsepower requirements by utilizing more efficient pumps. Worthington D-Line with closed impeller is the most efficient ANSI pump line over the broad range of operating conditions.

Based on our study of 110 random selections from 50 to 4000 gpm and from 60 to 400 feet total head and published rating curves, Worthington D-Line ANSI pumps came out with 4.56 points greater efficiency than the pumps of other major ANSI suppliers. The result was an average power savings of 7.3%. All of which means that over a 10-year period, the average D-Line ANSI pump will repay its initial cost 2 times. Using the formula shown below, it is estimated that the cost per horsepower for a single pump over 10 years could amount to \$1,500. Even considering inflationary effects on money over a 10-year period, that's still a savings of at least \$1,000 per horsepower.

Where the electric utility rate is 2c/kWh, the direct operating cost for a ten-year-life project would be*
 (2c/kWh) (8,760 h/yr) (0.746 kW/hp) (10 yr)
 0.85 motor efficiency = \$1,538/hp

*Formula for determining cost per horsepower. Source: Chemical Engineering Jan. 5, 1976 "Saving energy and costs in pumping systems."

Assuming an average rating of 25 hp per pump, a power savings of 7.3% means that 1.83 hp per pump will be saved. With a cost per horsepower of \$1,000, that's a savings of \$1,830 per pump, or \$183,000 for 100 pumps.

Looking at it another way, you realize full payback on your initial ANSI D-Line investment in 5 years.

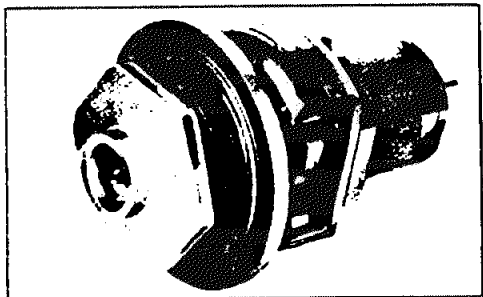

D-Line rotating assembly used in both horizontal and vertical units affords a substantial reduction in spare inventory.

Superior hydraulics insure greater efficiency and improved reliability.

Closed impellers operate longer at higher efficiencies.

Worthington D-Line ANSI pump hydraulics are designed around the closed impeller for a simple reason: **efficiency.**

Worthington experience and research have shown that closed impellers retain their efficiency better than impellers of open or semi-open design. The results of tests on identical pumps in identical systems — one pump fitted with an open impeller, the second with a closed design — are shown below (Figure 3). Although weight loss due to wear was equal for each pump, the reduction in performance for the open impeller was greater than for the closed design. After running the same length of time, closed impellers maintained their efficiencies better.

Reduce maintenance cost and downtime — no impeller adjustments.

The enclosed impeller requires no axial impeller adjustment. The internal clearance automatically

positions the impeller for maximum hydraulic performance. Downtime is reduced to the very minimum. With no adjustment required, maintenance time in a plant with several ANSI pumps is substantially reduced.

Interchangeable open impellers and wear plates to reduce maintenance costs.

As an alternative to the closed impeller, in special applications, D-Line ANSI pumps are also available with an open impeller and a cost-saving wear plate. A readily replaceable part, the wear plate is inexpensive when compared to wear surfaces of other designs, such as the stuffing box cover or the pump casing (Figure 4).

The inherent design of an open impeller causes axial thrust imbalance. Because of this (Figure 5), double row angular contact thrust bearings are standard on all D-Line ANSI open-impeller selections.

Should your operating conditions change in the future, open and closed impellers are fully interchangeable on all horizontal D-Line ANSI pumps.

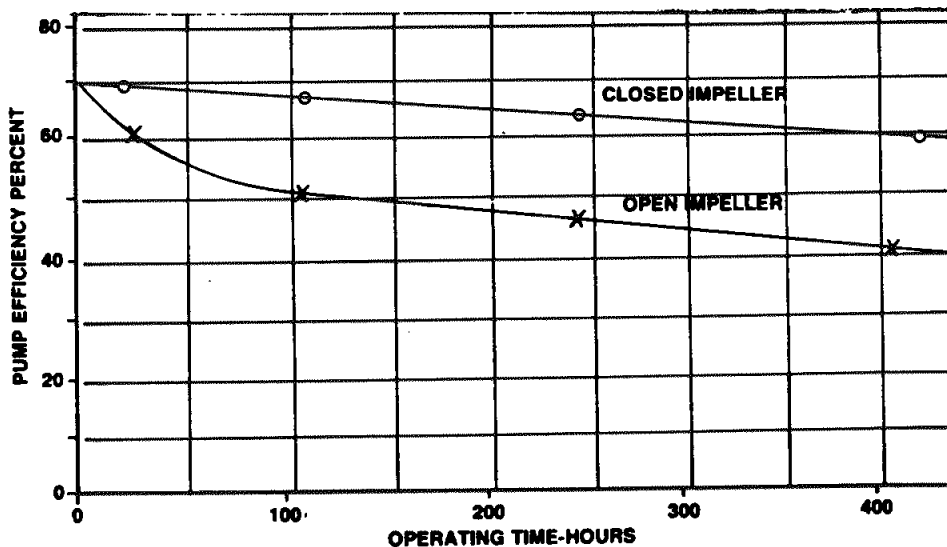

CLOSED IMPELLER



OPEN IMPELLER

Figure 3 — An efficiency curve for pumps tested in abrasive service. Right photo shows condition of closed and open pump impellers at the conclusion of an extensive testing program. Curve indicates closed impeller maintained its efficiency better.

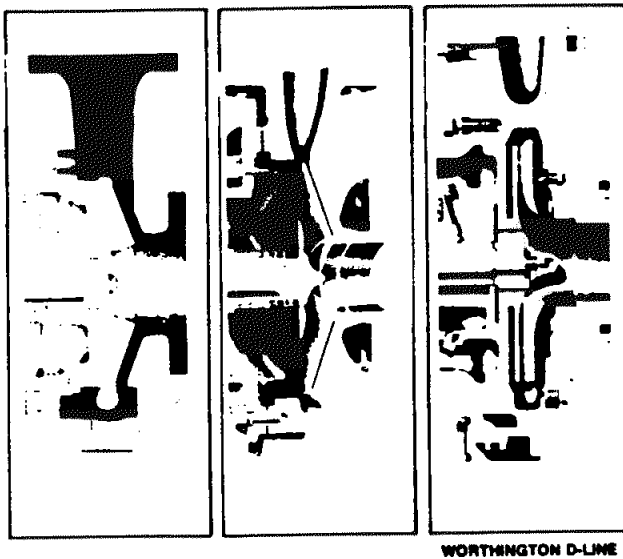

Figure 4 — The parts in brown are normally replaced because of wear: (left) casing, (middle) stuffing box cover, (right) wear plate.

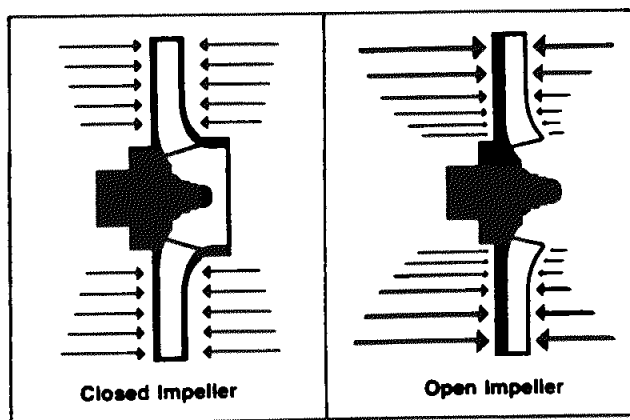

Figure 5 — By nature of its design, the enclosed impeller offers inherent axial hydraulic balance, minimizing thrust loads resulting in longer bearing life.

Unique inducer-impeller can cut system costs by reducing NPSH requirements.

The D-Line with the optional inducer can reduce NPSH requirements by as much as 50% (Figure 6). This is the first ANSI pump with an effective inducer.

When low pressures and high temperatures make NPSH a critical problem, the Worthington inducer acts to pull extra fluid into the impeller. This improved suction performance significantly reduces the NPSH requirements of the pump across its normal operating range. That means your system can be designed with smaller components — lower suction towers, smaller piping and valves, and smaller, higher-speed pumps without compromising performance.

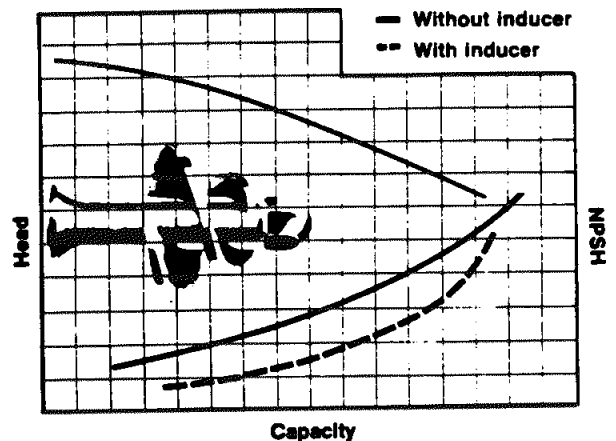
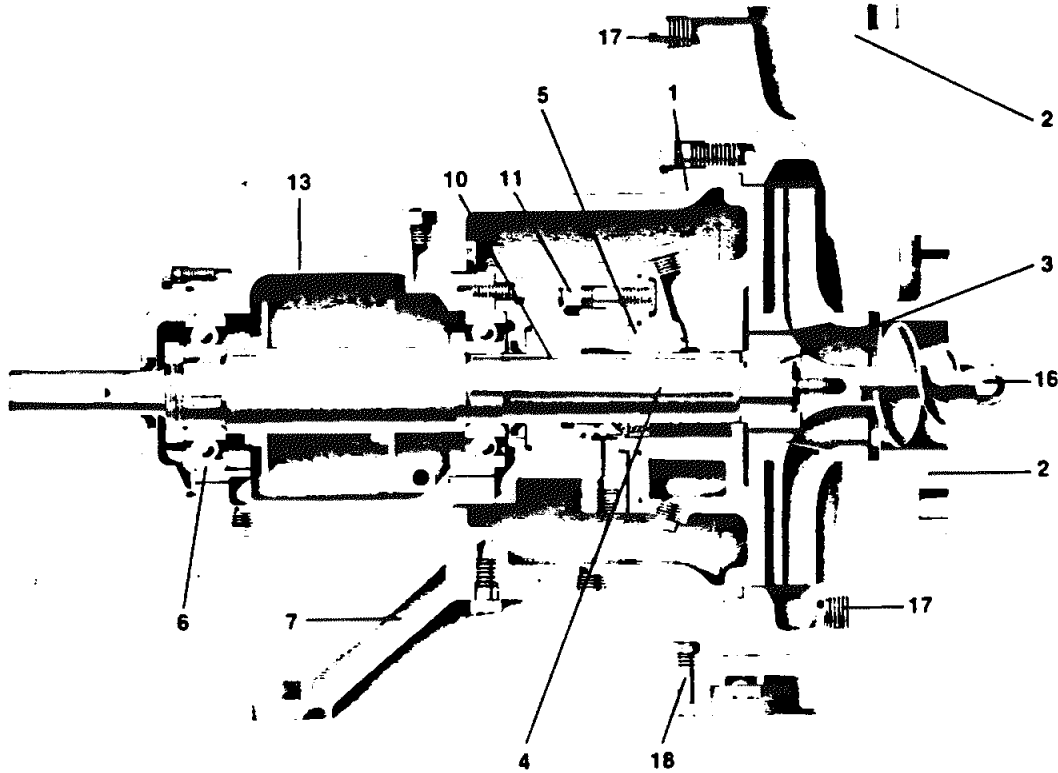
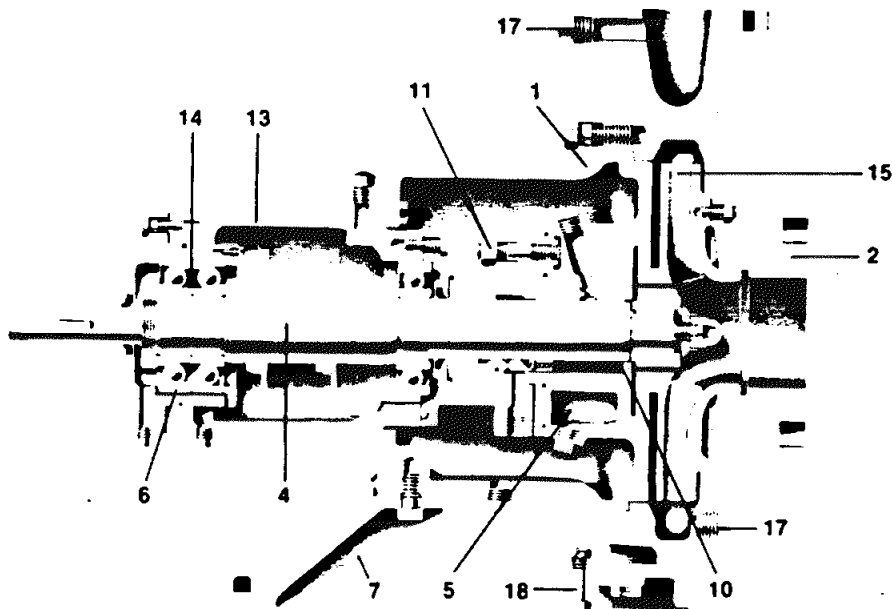

Figure 6 — Effect of Inducer-impeller on D-1000 and D-1160 NPSH requirements.

D-1000 with Closed Impeller



D-1000 with Open Impeller



D-LINE ANSI

D-Line ANSI Pumps

- 1 Back pull-out design.
- 2 150 pound ASA F.F. flanges. Standard 300 pound ASA F.F. flanges available.
- 3 Keyed-on, hydraulically balanced closed impellers for long life and high efficiency performance.
- 4 Heavy duty shaft with maximum deflection less than .002".
- 5 Jacketed convertible stuffing box utilizing packing or mechanical seal.
- 6 Standard bearings sized for average life of ten years with minimum two years.
- 7 Adapter support prevents unanticipated strains from being transmitted to bearings.
- 8 Top pull-out assembly.
- 9 Patented suction inlet design substantially reduces NPSH requirements.
- 10 Stainless steel shaft sleeve on ductile iron pumps.
- 11 Two piece packing gland.
- 12 Rugged, fabricated steel support allows precise alignment of frame and motor.
- 13 Interchangeable bearing cartridge.
- 14 Double row angular contact bearings.
- 15 Open impeller with renewable wear plate.
- 16 Optional inducer (available with open or closed impeller)
- 17 Vent & drain (optional).
- 18 Adjustable disassembly support bolt.

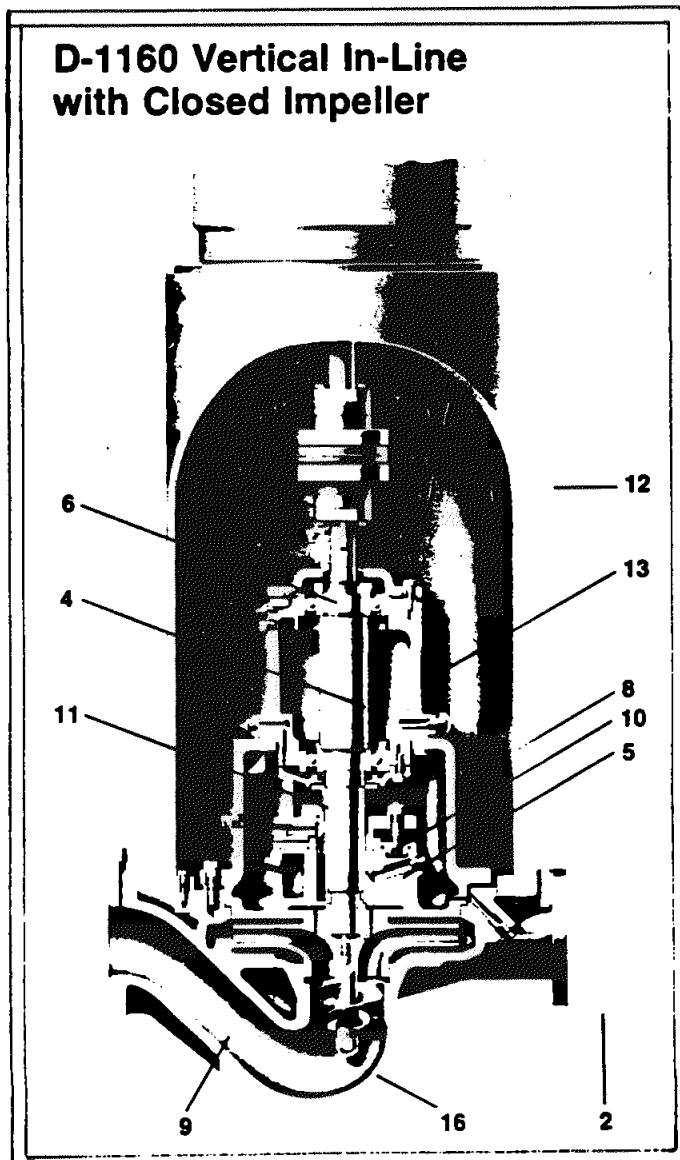

Patented vertical in-line suction inlet design.

The Worthington D-1160 inlet design is a product of an extensive research program which was established to produce a side inlet configuration which would not adversely affect the performance and NPSH characteristics of the pump.

The resultant design is based on well established fluid flow phenomenon, but the precise geometry and combination of features is unique. This inlet configuration has been granted U.S. Patent #3,910,715.



Proper sealing arrangements assure reliability.

Stuffing box data

Frame Size	O.D. of Sleeve	Packing Size	No. Rings	Gland Stud Diameter
1	1 1/4	1/4 x 3/16	5	3/8
3	1 3/4	3/8 x 3/8	5	1/2
5	2 1/4	1/2 x 1/2	5	3/4

Stuffing Box Pressure — D-1000 & D-1160

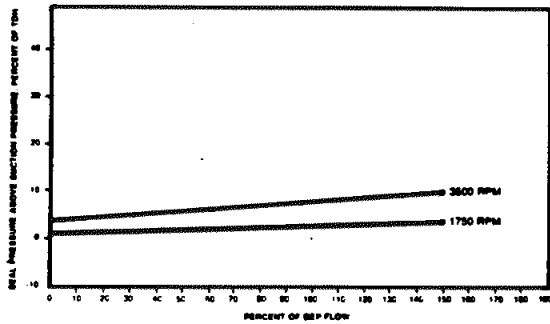

Stuffing Box temperature at various pumping temperatures with 4 GPM of 80°F cooling water.

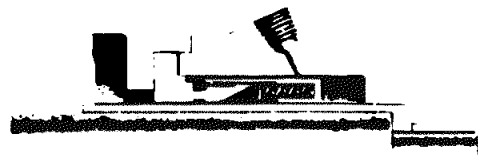
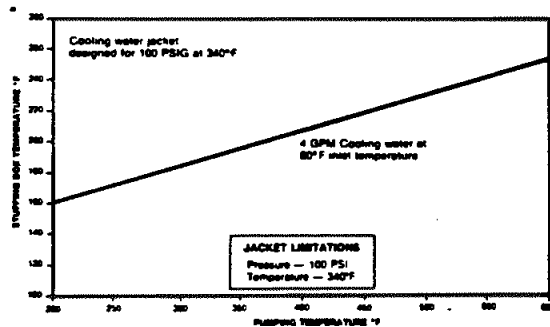

Single inside. Clamped.

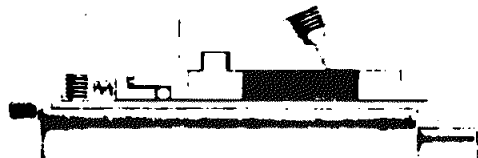

Single outside. Clamped seat.

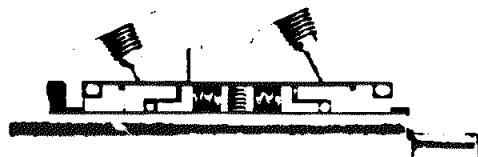

Double inside. "O" ring mounted.

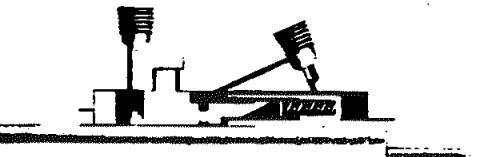

Single inside. With Vent and drain and throttle bushing.

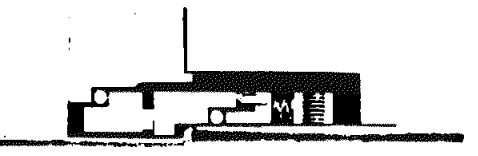

Single inside. Balanced.



Single inside. "O" ring mounted.

Unique design increases mechanical seal life.

Worthington's unique design was guided by mechanical seal experts. For top performance, they advised, give it ample room to operate in, and provide plenty of flushing to keep it cool and clean. That's the reason we've broken the common practice of shoehorning mechanical seals into stuffing box covers designed to house soft packing, with only thousandths of an inch of space around them.

The mechanical seal is contained in its own larger cavity. Free circulation provides unmatched cooling and lubrication of the seal face. The flushing action, which is direct from the back wearing ring of the impeller, is 5 to 10 times greater.

Either a conventional stuffing box or the unique mechanical seal cover (shown below) can be specified.

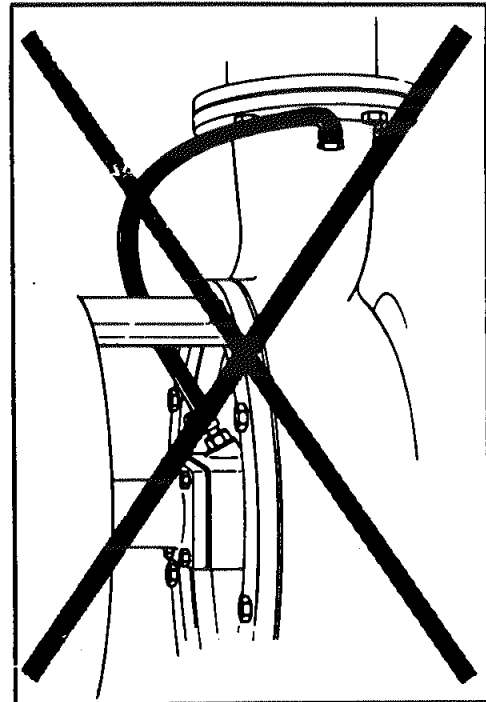
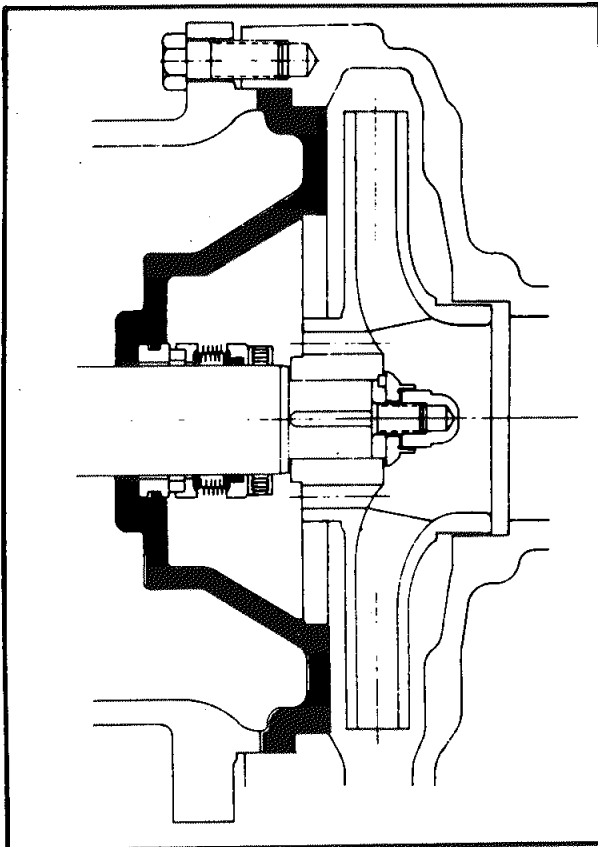

External flushing lines and attendant hazards are eliminated by the Worthington mechanical seal cover.

The Worthington mechanical seal cover provides a better seal environment for greater dependability. The self-flushing action keeps the seal running cooler and cleaner, ensuring longer seal life. It also eliminates the need for a recirculation line and mechanical seal gland.