



# Split System Condensing Units and Remote Chillers

---

20 to 120Tons  
50 and 60 Hz



---

November 2006

SS-PRC005-EN



## Introduction

---



Trane 20 through 120-ton air-cooled condensing units are the leaders in the split system marketplace. Designed for efficiency, reliability and flexibility, the Trane units have the most advanced design in the industry.

Twenty through 120-ton units feature the Trane 3-D™ Scroll compressor, solid-state controls and Trane's exclusive Packed Stock Plus availability for quick shipment. These innovations make an already proven product even better!

# Contents

---

<b>Introduction</b>	2
<b>Features and Benefits</b>	4
<b>Application Considerations</b>	6
<b>Selection Procedure</b>	7
Model Number Description	8
<b>General Data</b>	10
<b>Performance Data</b>	12
Performance Adjustment Factors	11
<b>Controls</b>	25
<b>Electric Power</b>	27
<b>Dimension and Weights</b>	29
<b>Mechanical Specifications</b>	46



## Features and Benefits

### Trane 3-D Scroll Compressor Simple Design with 70% Fewer Parts

Fewer parts than an equal capacity reciprocating compressor means significant reliability and efficiency benefits. The single orbiting scroll eliminates the need for pistons, connecting rods, wrist pins and valves. Fewer parts lead to increased reliability. Fewer moving parts, less rotating mass and less internal friction means greater efficiency than reciprocating compressors.

The Trane 3-D Scroll provides important reliability and efficiency benefits. The 3-D Scroll allows the orbiting scrolls to touch in all three dimensions, forming a completely enclosed compression chamber which leads to increased efficiency. In addition, the orbiting scrolls only touch with enough force to create a seal; there is no wear between the scroll plates. The fixed and orbiting scrolls are made of high strength cast iron which results in less thermal distortion, less leakage, and higher efficiencies. The most outstanding feature of the 3-D Scroll compressor is that slugging will not cause failure. In a reciprocating compressor, however, the liquid or dirt can cause serious damage.

### Low Torque Variation

The 3-D Scroll compressor has a very smooth compression cycle; torque variations are only 30 percent of that produced by a reciprocating compressor. This means that the scroll compressor imposes very little stress on the motor resulting in greater reliability. Low torque variation reduces noise and vibration.

### Suction Gas Cooled Motor

Compressor motor efficiency and reliability is further optimized with the latest scroll design. Cool suction gas keeps the motor cooler for longer life and better efficiency.

### Proven Design Through Testing and Research

With over twenty years of development and testing, Trane 3-D Scroll compressors have undergone more than 400,000 hours of laboratory testing and field operation. This work combined with over 25 patents makes Trane the



worldwide leader in air conditioning scroll compressor technology.

### Voltage Power Supply

20 through 120-ton units have four voltage options in 200, 230, 460 and 575, resulting in improved stock coverage.

### Passive Manifolding

Trane offers a parallel manifolding scheme that uses no moving mechanical parts. This feature assures continuous oil return, again providing greater system reliability. And greater reliability means optimal performance over the life of the unit.

### System Control Options

Trane offers four system control options on 20 through 60-ton units and three system control options on the 80 through 120-ton units, each using solid-state electronics. These options allow the unit to be ordered only with the controls needed. In addition, they

come factory installed, saving field installation costs.

### Coil Frost Protection

Trane offers FROSTAT™ with the VAV system control option on the 20 through 120-ton units. FROSTAT is the industry's most reliable method of coil frost protection and assures that your system will provide energy efficient comfort at part load conditions.

### Remote Evaporative Liquid Chiller (EVP/STX) Control Option

This option allows chilled water to be generated remotely from the condensing section.

# Features and Benefits



## 20 Through 60-Ton Units

### Standard Features

- Trane 3-D® Scroll compressors
- Factory-installed Discharge and Liquid Line Service Valves
- Passive manifolding for 3-D Scroll compressors
- Standard ambient operating range 40°F to 115°F
- 14-gauge galvanized steel frame
- Louvered panels for coil protection
- Slate gray air-dry paint finish (exceeds 672 hour salt spray test in accordance with ASTM B117)

### Optional Features

- Non-fused disconnect
- Low ambient option
- Hot gas bypass to the evaporator inlet
- Suction service valve
- Pressure gauges
- Return air sensor
- Copper finned condenser coil
- Flow switch
- Unit spring isolators
- Neoprene-in-shear isolators
- UL/CSA approval (not available for 50 Hz)
- Packed Stock Plus program
- Extended Compressor Warranty
- Special coil coating for corrosion resistance
- Four systems control options

## 80 Through 120-Ton Units

### Standard Features

- Trane 3-D Scroll compressors
- Factory-installed discharge and liquid line service valves
- Standard ambient operating range 40°F to 115°F
- Independent refrigerant circuits
- 14-gauge galvanized steel frame
- Louvered panels for coil protection
- Slate gray air-dry paint finish (exceeds 672 hour salt spray test in accordance with ASTM B117)

### Optional Features

- Low ambient option
- Hot gas bypass to the evaporator inlet
- Suction service valve
- Pressure gauges
- Copper finned condenser coil
- Spring isolators
- Flow switch
- UL/CSA approval
- Packed Stock Plus Availability
- Extended Compressor Warranty
- Special coil coating for corrosion resistance
- Three system control options

## Packed Stock Plus

Trane 20 through 120-ton air-cooled condensing units are available through the most flexible packed stock program in the industry. Trane knows that you want your units on the job site, on time, with the options you need.

Packed Stock Plus provides you with the controls and options you need — options like hot gas bypass, isolators and refrigerant gauges. You no longer have to settle for a basic unit requiring many field installed options to meet your job schedule. Now, you can get a customized unit from the factory in record time.

The Trane Packed Stock Plus program provides more control over unit selection and scheduling than ever before. Trane wants to make it easy for you to do business with them.



# Application Considerations

Certain application constraints should be considered when sizing, selecting and installing Trane air-cooled condensing units. Unit reliability is dependent upon these considerations. Where your application varies from the guidelines presented, it should be reviewed with the local Trane sales engineer.

## Unit Sizing

Unit capacities are listed in the performance data section on pages 11 to 24. Intentionally oversizing a unit to assure adequate capacity is not recommended. Erratic system operation and excessive compressor cycling are often a direct result of an oversized condensing unit. In addition, an oversized unit is usually more expensive to purchase, install and operate. If oversizing is desired, consider using two units.

## Unit Placement

A base or foundation is not required if the selected unit location is level and strong enough to support the unit's operating weight (as listed on page 45).

## Isolation and Sound Emission

The most effective form of isolation is to locate the unit away from any sound sensitive area. Structurally transmitted sound can be reduced by using spring or rubber isolators. The isolators are effective in reducing the low frequency sound generated by compressors and, therefore, are recommended for sound sensitive installations. An acoustical engineer should always be consulted on critical applications.

For maximum isolation effect, the refrigeration lines and electrical conduit should also be isolated. Use flexible electrical conduit. State and local codes on sound emissions should always be considered. Since the environment in which a sound source is located affects sound pressure, unit placement must be carefully evaluated.

## Servicing

Adequate clearance for compressor servicing should be provided. Recommended minimum space envelopes for servicing are located in the dimensional data section of this catalog and can serve as guidelines for providing adequate clearance. The minimum space

envelopes also allow for control panel door swing and routine maintenance requirements. Local code requirements may take precedence.

## Unit Location

Unobstructed flow of condenser air is essential for maintaining condensing unit capacity and operating efficiency. When determining unit placement, careful consideration must be given to assure proper air flow across the condenser heat transfer surface. Failure to heed these considerations will result in warm air recirculation and coil air flow starvation.

Warm air recirculation occurs when discharge air from the condenser fans is recycled back at the condenser coil inlet. Coil starvation occurs when free air flow to the condenser is restricted.

Both warm air recirculation and coil starvation cause reductions in unit efficiency and capacity. In addition, in more severe cases, nuisance unit shutdowns will result from excessive head pressures. Accurate estimates of the degree of efficiency and capacity reduction are not possible due to the unpredictable effect of varying winds.

When hot gas bypass is used, reduced head pressure increases the minimum ambient condition for proper operation. In addition, wind tends to further reduce head pressure. Therefore, it is advisable to protect the air-cooled condensing unit from continuous direct winds exceeding 10 miles per hour.

Debris, trash, supplies, etc., should not be allowed to accumulate in the vicinity of the air-cooled condensing unit. Supply air movement may draw debris between coil fins and cause coil starvation. Special consideration should be given to units operating in low ambient temperatures. Condenser coils and fan discharge must be kept free of snow and other obstructions to permit adequate air flow for satisfactory unit operation.

## Effect of Altitude on Capacity

Condensing unit capacities given in the performance data tables on pages 11 to 24 are at sea level. At elevations substantially above sea level, the decreased air density will decrease condenser capacity and, therefore, unit

capacity and efficiency. The adjustment factors in Table PAF-1 can be applied directly to the catalog performance data to determine the unit's adjusted performance.

## Ambient Considerations

Start-up and operation at lower ambients requires sufficient head pressure be maintained for proper expansion valve operation. At higher ambients, excessive head pressure may result. Standard operating conditions are 40°F to 115°F. With a low ambient damper, operation down to 0°F is possible. Minimum ambient temperatures are based on still conditions (winds not exceeding five mph). Greater wind velocities will result in increased minimum operating ambients. Units with hot gas bypass have a minimum operating ambient temperature of 10°F. For proper operation outside these recommendations, contact the local Trane sales office.

## Coil Frost Protection

FROSTAT™ is standard on condensing units when the VAV option is ordered. FROSTAT consists of a ship-with thermostat for field installation on the suction line. A timer is also factory-installed to avoid short cycling. FROSTAT cycles the compressor off when the suction line is below 30°F. Refer to S/S-EB-43 for more detail.

When hot gas valves must be used on 20 to 120-ton units, they can be ordered as a miscellaneous option. 20 to 30-ton units require one valve; 40 to 60-ton units also require one valve except when no system control option is selected; this option requires two valves. 80 to 120-ton units require one valve when Supply Air VAV control is selected. Two valves are required on all other 80 to 120-ton control options.

## Refrigerant Piping

Special consideration must always be given to oil return. Minimum suction gas velocities must always be maintained for proper oil return. Utilize appropriate piping tools for line sizing such as the CDS Refrigerant Piping Program. For special applications, call Clarksville Product Support.

# Selection Procedure

## RAUC/AIR HANDLER

### Selection Procedure

Net capacity curves for the RAUC condensing units are given on pages 14 through 23. These graphs can be used to cross plot an evaporator (EVP/STX) performance curve. The resultant point of intersection will be the system design balance point. The design operating suction temperature and capacity can then be read directly from the graph. (Note: It is usually necessary to account for suction and liquid line losses in the performance accordingly. The actual losses are determined by the interconnecting piping.)

To plot the evaporator performance curve it is only necessary to obtain gross evaporator capacities for the given entering air conditions and cfm at two different saturated suction temperatures. The Trane Refrigeration Coil Computer Selection Program can be used to conveniently provide the necessary evaporator capacity values at the selected suction temperatures.

### RAUC/EVP(STX) Selection Procedure

Preselected RAUC/EVP(STX) capacities are provided on pages 12 and 13. To select for other RAUC/EVP(STX) combinations or conditions, four quantities must be known. They are:

- a. Entering (EWT) or leaving (LWT) water temperature.
- b. Net cooling load (T).
- c. Water temperature drop (dt).
- d. Waterflow rate in gallons per minute (gpm). Knowing any two of the last three variables (T, dt, and gpm) will determine the third since  $T = (Gpm \times dt)/24$ .

### Standard Selection Procedure

1. Determine: EWT, T, dt, gpm.
2. Select an evaporator (EBP) and split condensing unit (RAUC) to mix-match.
3. Enter Charts PD-18, PD-20, and PD-21 to find ITD/dt.
4. From Step 3 calculate the saturated suction temperature (SST) of the chiller at the given load using the formula  $SST = EWT - [(ITD/dt) \times dt]$ .
5. Enter the appropriate RAUC capacity chart on pages 14-23 with the result on SST and given load, T. If this point is below or on the proper condensing unit performance curve at the same suction temperature, the RAUC/EVP(STX) combination will meet the desired load. If above, try a larger chiller and/or condensing unit. Repeat Steps 2 through 5 until the most economical mix-match has been achieved.

### Example

Given:  
 Ambient Air = 95°F  
 Supply Water Temperature = 45°F  
 Waterflow = 230 Gpm  
 Water Temperature Drop = 10°F

#### Step 1:

$EWT = LWT + dt = 45^\circ F + 10^\circ F = 55^\circ F$   
 $Gpm = 230 \text{ gpm (given)}$   
 $dt = 10^\circ F \text{ (given)}$

#### Step 2:

Choose a nominal RAUC and STX:  
 RAUC-D10 and 100-ton STX

#### Step 3:

$Gpm/\text{nominal tonnage} = 230/100 = 2.30$   
 ITD/dt is read from Chart PD-21 as 1.70, assuming .0005 fouling factor.

#### Step 4:

$SST = EWT - [(ITD/dt) \times dt] = [55 - (1.70 \times 10)] = 38.0^\circ F = SST$   
 Enter Chart PD-14 at 38.0°F SST and 95 ambient air. The condensing unit will produce 1182 MBh at 38.0°F SST, therefore the 100-ton STX/RAUC-D10 is the proper selection.

### Alternative Selection Procedure

Given: The same information as in the standard selection procedure plus a predetermined condensing unit.

Enter the specified RAUC condensing unit performance curve with the appropriate cooling load T, to determine the minimum required suction temperature.

Enter Chart PD-14 with ITD/dt (EWT-saturated suction temperature/dt) to determine a gpm/nominal tonnage. Since the gpm is known, the smallest nominal size EVP/STX can therefore be calculated.

### Example:

Given:  
 Ambient Air = 95°F  
 Condensing Unit - RAUC-C80  
 Supply Water Temperature - 45°F  
 $dt = 10^\circ F$   
 $T = 80.0 \text{ Tons}$

#### Step 1:

$EWT = LWT + dt = 45^\circ F + 10^\circ F = 55^\circ F$   
 $dt = 10^\circ F$   
 $T = 80.0 \text{ Tons (960 MBh)}$   
 $Gpm = 152$

#### Step 2:

Enter Chart PD-13 at 95°F and 80.0 tons to read the saturated suction temperature (SST) as 39.7.

#### Step 3:

Enter Chart PD-21 at an  $ITD/dt = (EWT - SST)/dt = (55 - 39.7)/10 = 1.53$

Then read the maximum gpm/nominal tons as 1.87 (assume .0005 fouling factor). Therefore since  $1.87 = Gpm/\text{Nominal Ton} = 152/1.87 = 81.4 \text{ Tons}$ . An 80-ton STX is the optimum selection.



# Model Number Description

20 - 60Ton

## Air-Cooled Condensing Units

### 20 TO 60-TON AIR-COOLED CONDENSING UNITS<sup>1</sup>

R   A   U   C   C20   E   B   A   1   0   A   0   0   0   0   0   0   0   0  
 1   2   3   4   5,6,7   8   9   10   11   12   13   14   15   16   17   18   19   20   21

#### DIGIT 1 –UNITTYPE

R = Condensing Unit

#### DIGIT 2 –CONDENSER

A = Air Cooled

#### DIGIT 3 –AIRFLOW

U = Upflow

#### DIGIT 4 –DEVELOPMENT SEQUENCE

C = Third

#### DIGITS 5,6,7 –NOMINAL CAPACITY

C20 = 20Tons  
 C25 = 25Tons  
 C30 = 30Tons  
 C40 = 40Tons  
 C50 = 50Tons  
 C60 = 60Tons

#### DIGIT 8 –VOLTAGE AND START CHARACTERISTICS

E = 200/60/3 XL  
 D = 415/50/3 XL  
 F = 230/60/3 XL  
 4 = 460/60/3 XL  
 5 = 575/60/3 XL  
 9 = 380/50/3 XL

#### DIGIT 9 –SYSTEM CONTROL

B = No System Control  
 C = Constant Volume Control  
 E = Supply Air VAV Control  
 P = EVP Control

#### DIGIT 10 –DESIGN SEQUENCE

(Factory Assigned)  
 A = First  
 B = Second  
 Etc.

#### DIGIT 11 –AMBIENT CONTROL

0 = Standard  
 1 = 0°F (Low Ambient Dampers)

#### DIGIT 12 –AGENCY APPROVAL

0 = None  
 3 = UL/CSA (not available for 50 Hz)

#### DIGIT 13-21 –MISCELLANEOUS

A = Unit Disconnect Switch  
 B = Hot Gas Bypass  
 D = Suction Service Valve  
 F = Pressure Gauges  
 G = Return Air Sensor  
 H = Copper Fins  
 T = Flow Switch (EVP Control Option Only)  
 1 = Spring Isolators  
 2 = Rubber Isolators  
 4 = 5-Year Compressor Warranty  
 9 = Packed Stock Designator

## Remote Chillers

### 20 TO 60-TON REMOTE CHILLERS

EVP   B   C20   A   1   \*  
 1,2,3   4   5,6,7   8   9   10

#### DIGIT 1,2,3 –UNITTYPE

EVP = Evaporative Liquid Chiller

#### DIGIT 4 –DEVELOPMENT SEQUENCE

(Factory Assigned)  
 A = First  
 B = Second  
 Etc.

#### DIGITS 5,6,7 –NOMINAL CAPACITY

C20 = 20Tons  
 C25 = 25Tons  
 C30 = 30Tons  
 C40 = 40Tons  
 C50 = 50Tons  
 C60 = 60Tons

#### DIGIT 8 –NUMBER OF CIRCUITS

A = Single (20-30Ton Units)  
 D = Dual (40-60Ton Units)

#### DIGIT 9 –TUBE MATERIAL

1 = Copper

#### DIGIT 10 –DESIGN SEQUENCE

(Factory Assigned)  
 A = First  
 B = Second  
 Etc.

#### Definition of Abbreviations Used in This Catalog

AL — Aluminum  
 ASTM — American Society of Testing and Materials  
 CFM — Cubic Feet Per Minute  
 Conn. — Connection  
 CSA — Canadian Standards Association  
 CU — Copper  
 DIA. — Diameter  
 dt — Temperature Difference  
 EER — Energy Efficiency Ratio (Btu/Watt-Hour)

EWT — Entering Water (Solution) Temperature  
 (F) — Units of Temperature in Degrees Fahrenheit  
 GPM — Gallons Per Minute  
 ID — Inside Diameter  
 (INT) — Internal  
 IPLV — Integrated Part Load Value  
 ITD — Initial Temperature Difference  
 k — Thermal Conductivity  
 KO — Knock Out

1. The service digit for each model number contains 21 digits; all 21 digits must be referenced.





# Model Number Description

## 80 - 120 Ton

### Air-Cooled Condensing Units

#### 80 TO 120-TON AIR-COOLED CONDENSING UNIT<sup>1</sup>

R   A   U   C   C80   4   B   A   0   0   2   B   0   0   0   0   0

1   2   3   4   5,6,7   8   9   10   11   12   13   14   15   16   17   18   19

#### **DIGIT 1 – UNITYTYPE**

R = Remote Condensing Unit

#### **DIGIT 2 – CONDENSER**

A = Air-Cooled

#### **DIGIT 3 – AIRFLOW**

U = Upflow

#### **DIGIT 4 – DEVELOPMENT SEQUENCE**

C = Third

#### **DIGITS 5,6,7 – NOMINAL CAPACITY**

C80 = 80 Tons  
D10 = 100 Tons  
D12 = 120 Tons

#### **DIGIT 8 – VOLTAGE AND START CHARACTERISTICS**

E = 200/60/3 XL  
F = 230/60/3 XL  
4 = 460/60/3 XL  
5 = 575/60/3 XL  
\* = 380/50/3 XL<sup>2</sup>  
\* = 415/50/3 XL<sup>2</sup>

#### **DIGIT 9 – SYSTEM CONTROL**

B = No System Control  
E = Supply Air VAV Control  
P = STX Control

#### **DIGIT 10 – DESIGN SEQUENCE**

(Factory Assigned)  
A = First  
B = Second  
Etc.

#### **DIGIT 11 – AMBIENT CONTROL**

0 = Standard  
1 = 0°F (Low Ambient Dampers)

#### **DIGIT 12 – AGENCY APPROVAL**

0 = None  
3 = UL/CSA (not available for 50 Hz)

#### **DIGIT 13 – NUMBER OF CIRCUITS**

2 = Dual (All 80-120 Ton)

#### **DIGIT 14-19 – MISCELLANEOUS**

B = Hot Gas Bypass Valve  
D = Suction Service Valve  
F = Pressure Gauges  
H = Copper Fins  
1 = Spring Isolators  
3 = Flow Switch (EVP Control Option Only)

### Remote Chillers

#### 80 TO 120-TON REMOTE CHILLERS

STX   B   C80   D   1   A

1,2,3   4   5,6,7   8   9   10

#### **DIGIT 1,2,3 – UNITYTYPE**

STX = Evaporator Liquid Chiller

#### **DIGIT 4 – DEVELOPMENT SEQUENCE**

(Factory Assigned)  
A = First  
B = Second  
Etc.

#### **DIGITS 5,6,7 – NOMINAL CAPACITY**

C80 = 80 Tons  
D10 = 100 Tons  
D12 = 120 Tons

#### **DIGIT 8 – NUMBER OF CIRCUITS**

D = Dual (80-120 Ton Units)

#### **DIGIT 9 – TUBE MATERIAL**

1 = Copper

#### **DIGIT 10 – DESIGN SEQUENCE**

(Factory Assigned)  
A = First  
B = Second  
Etc.

#### Definition of Abbreviations Used in This Catalog

KW – Kilowatt (Unit of Power)  
lbs. – Pounds (Unit of Weight)  
Loc. – Location  
LRA – Locked Rotor Amps  
LWT – Leaving Water (Solution) Temperature  
(MBH) – 1 x 10<sup>3</sup> Btuh  
MTG. – Mounting  
NPS – Nominal Pipe Size

OD – Outside Diameter  
PD – Pressure Drop (Units are Feet of Water)  
RLA – Rated Load Amps  
SST – Saturated Suction Temperature  
UL – Underwriters Laboratories Inc.  
VAV – Variable Air Volume  
W/ – With  
W/O – Without  
XL – Across-the-Line-Start

1. The service digit for each model number contains 19 digits; all 19 digits must be referenced.  
2. Contact the local Trane Sales Office for ordering information regarding 90-120 50 Hz models.



# General Data

**Table GD-1 –General Data –20-120 Ton Condensing Units**

Nominal Tonnage	20	25	30	40	50	60	80	100	120
Model Number	RAUC-C20	RAUC-C25	RAUC-C30	RAUC-C40	RAUC-C50	RAUC-C60	RAUC-C80	RAUC-D10	RAUC-D12
<b>Compressor Data</b>									
Type	Scroll	Scroll	Scroll	Scroll	Scroll	Scroll	Scroll	Scroll	Scroll
Manifolded Sets									
Circuit #1	10T + 10T	10T + 15T	15T + 15T	10T + 10T	10T + 15T	15T + 15T	10T + 15T + 15T	10T + 10T +15T +15T	15T + 15T +15T +15T
Circuit # 2	N/A	N/A	N/A	10T + 10T	10T + 15T	15T + 15T	10T + 15T + 15T	10T + 10T +15T +15T	15T + 15T +15T +15T
Unit Capacity Steps (%)	100-50	100-40	100-50	100-75-50-25	100-80-60-30	100-75-50-25			
No Control & VAV Option							*19-38-50-63-81-100	*20-40-55-70-85-100	*25-50-63-75-88-100
EVP/STX Option							*19-38-50-63-81-100	*20-40-55-70-85-100	*25-50-63-75-88-100
<b>Condenser Fan Data</b>									
Quantity/Fan Dia./Type	2/26"/Prop.	3/26"/Prop.	3/26"/Prop.	4/26"/Prop.	6/26"/Prop.	6/26"/Prop.	8/26"/Prop.	12/26"/Prop.	12/26"/Prop.
Fan Drive Type	Direct	Direct	Direct	Direct	Direct	Direct	Direct	Direct	Direct
No. of Motors/Hp Each	2/1.0	3/1.0	3/1.0	4/1.0	6/1.0	6/1.0	8/1.0	12/1.0	12/1.0
Nominal Total Cfm	14000	18300	20900	28200	35600	40800	49600	66800	76000
<b>Condenser Coil Data</b>									
Number of Coils/Size (Inches)	1/71x71	1/71x71	1/45x71 1/49x71	2/65x70	2/51x96	2/66x96	4/65x70	4/51x96	4/66x96
Face Area (Sq. Ft.)	35.0	35.0	46.1	63.2	67.1	88.0	126.4	134.2	176.0
Rows/Fins Per Ft.	3/144	3/144	3/144	3/144	3/144	3/144	3/144	3/144	3/144
Condenser Storage Capacity (Lbs.) (2)	76	76	96	136	142	184	272	284	368
<b>Refrigerant Data (3)</b>									
No. Refrigerant Circuits	1	1	1	2	2	2	2	2	2
Refrigerant Type	R-22	R-22	R-22	R-22	R-22	R-22	R-22	R-22	R-22
Refrigerant Operating Charge (Lbs) (1) (4)	28	31	40	58	62	80	116	124	160
<b>Minimum Outdoor Air Temperature for Mechanical Cooling</b>									
Standard Ambient	40-115	40-115	40-115	40-115	40-115	40-115	40-115	40-115	40-115
Operating Range (F)									
Low Ambient Option (F)	0	0	0	0	0	0	0	0	0

**Notes:**

1. Operating charge is approximate for condensing unit only, and does not include charge for low side or interconnecting lines.
2. Condenser storage capacity is given at conditions of 95°F outdoor temperature, and 95% full.
3. Refer to Refrigerant Piping under Application Considerations on Page 6.
4. Condensing units are shipped with a nitrogen holding charge only.

**Table GD-2 –Evaporator Chillers –20-120 Tons**

Nominal Tonnage	20	25	30	40	50	60	80	100	120
No. Of Circuits	1	1	1	2	2	2	2	2	2
Volume Shell (Gal) (1)	11.7	10.7	16.3	13.8	21.0	18.5	43.1	35.0	47.9
Tube Pull (in.) (2)	73	73	74	74	96	96	95	95	95
Refrigerant Operating Charge	8	10	12	16	20	24	26.8	33.4	40.4

**Notes:**

1. Shell volume is for waterside only.
2. Tube pull given is length of the evaporator.
3. Operating charge is approximate and for the evaporator chiller only.

**Table GD-3 –EER Data –Condensing Unit Only (1)**

Nominal Tonnage	Model Number	Net Capacity (MBH)	Total Unit Compressor KW	Condenser Fan KW Each/Total	Control KW	Condensing Unit		
						Total KW	EER	IPLV
20	RAUC-C20	239	19.8	0.9/1.8	0.25	21.9	10.9	15.5
25	RAUC-C25	314	25.3	0.9/2.7	0.25	28.3	11.1	15.2
30	RAUC-C30	376	30.4	0.9/2.7	0.25	33.3	11.3	16.2
40	RAUC-C40	507	40.3	0.9/3.6	0.40	44.3	11.5	16.4
50	RAUC-C50	626	51.2	0.9/5.4	0.40	57.0	11.0	15.7
60	RAUC-C60	748	61.2	0.9/5.4	0.40	67.0	11.2	16.2
80	RAUC-C80	1045	87.9	0.9/7.2	0.50	95.6	10.9	16.1
100	RAUC-D10	1300	110.9	0.9/10.8	0.50	122.1	10.7	15.3
120	RAUC-D12	1560	131.5	0.9/10.8	0.50	142.6	10.9	16.2

**Notes:**

1. Condensing unit only ratings are in accordance with ARI standard 365. Full load ratings are at 95°F entering air temperature, and refrigerant conditions entering the condensing unit of 45°F saturated and 60°F actual temperature. Part load ratings are at 80°F entering air temperature and refrigerant conditions entering the condensing unit of 50°F saturated suction and 65°F actual temperature.



# Performance Adjustment Factors

**Table PAF-1 –Altitude Correction Multiplier for Capacity**

Altitude (Ft.)	2,000	4,000	6,000	8,000	10,000
Condensing Unit Only	0.982	0.960	0.933	0.902	0.866
Condensing Unit / Air Handling Unit Combination	0.983	0.963	0.939	0.911	0.881
Condensing Unit With Evap.	0.986	0.968	0.947	0.921	0.891

**Table PAF-2 –Glycol Adjustment Factor for 20-60 Ton Split Condensing Units with the Remote Chiller (EVP/STX) Option**

Leaving Solution Temp.	Percent of Ethylene Glycol by Weight																	
	0%			10%			20%			30%			40%			50%		
Freezing Point = 32°F	Freezing Point = 24°F																	
CAP	GPM	KW	CAP	GPM	KW	CAP	GPM	KW	CAP	GPM	KW	CAP	GPM	KW	CAP	GPM	KW	
10°F	—	—	—	—	—	—	.833	.875	.952	.822	.912	.952	.811	.954	.945	.800	1.005	.945
15°F	—	—	—	—	—	—	.850	.904	.959	.850	.937	.959	.840	.983	.959	.830	1.029	.953
20°F	—	—	—	—	—	—	.882	.928	.971	.873	.962	.965	.864	1.008	.965	.855	1.057	.960
25°F	—	—	—	.909	.924	.977	.901	.952	.977	.901	.990	.972	.893	1.031	.972	.876	1.083	.972
30°F	—	—	—	.925	.947	.983	.925	.972	.983	.917	1.009	.978	.910	1.053	.978	.895	1.101	.978
35°F	—	—	—	.945	.963	.989	.938	.989	.989	.931	1.023	.984	.924	1.066	.984	.917	1.115	.978
40°F	1.000	1.000	1.000	.956	.974	.984	.949	1.000	.984	.943	1.034	.984	.937	1.077	.984	.930	1.124	.979
45°F	1.000	1.000	1.000	.965	.981	.990	.959	1.005	.990	.953	1.039	.985	.947	1.080	.985	.936	1.129	.979
50°F	1.000	1.000	1.000	.962	.982	.990	.957	1.007	.990	.951	1.038	.990	.946	1.079	.985	.935	1.124	.985

**Table PAF-3 –Glycol Adjustment Factor for 80-120 Ton Split Condensing Units with the Remote Chiller (EVP/STX) Option**

Leaving Solution Temp.	Percent of Ethylene Glycol by Weight																	
	0%			10%			20%			30%			40%			50%		
Freezing Point = 32°F	Freezing Point = 24°F																	
CAP	GPM	KW	CAP	GPM	KW	CAP	GPM	KW	CAP	GPM	KW	CAP	GPM	KW	CAP	GPM	KW	
10°F	—	—	—	—	—	—	.931	.980	.959	.924	1.023	.954	.916	1.075	.949	.907	1.131	.944
15°F	—	—	—	—	—	—	.943	.991	.967	.936	1.035	.962	.928	1.085	.957	.919	1.140	.952
20°F	—	—	—	.998	1.010	1.000	.955	1.003	.973	.948	1.044	.973	.941	1.094	.969	.933	1.149	.964
25°F	—	—	—	.998	1.014	1.000	.967	1.016	.979	.961	1.056	.979	.954	1.106	.975	.946	1.160	.970
30°F	—	—	—	.998	1.015	.996	.978	1.030	.984	.973	1.068	.984	.966	1.117	.980	.958	1.173	.976
35°F	—	—	—	.998	1.016	1.000	.987	1.039	.992	.982	1.078	.992	.975	1.124	.989	.968	1.178	.981
40°F	1.000	1.000	1.000	.998	1.016	1.000	.994	1.042	.996	.988	1.081	.993	.982	1.127	.989	.974	1.178	.986
45°F	1.000	1.000	1.000	.997	1.016	.997	.996	1.045	.997	.991	1.083	.993	.985	1.126	.990	.977	1.178	.986
50°F	1.000	1.000	1.000	.997	1.016	1.000	.997	1.046	1.000	.992	1.082	.997	.985	1.124	.990	.978	1.175	.987



# Performance Data

## 20 - 60Tons

**Table PD-1 –Gross System Capacity Data –20-60 Ton Condensing Unit with Evaporator Chiller**

Condensing Unit-Nominal Tons	Model	Leaving Chilled Water Temp.	Outside Ambient Temperature Entering Condenser (F)							
			85		95		105		115	
			Tons	Kw	Tons	Kw	Tons	Kw	Tons	Kw
20	RAUC C20 With 20Ton Chiller	40	16.3	17.1	15.5	18.8	14.6	20.9	13.7	23.2
		42	16.8	17.2	16.0	19.0	15.1	21.1	14.2	23.4
		45	17.6	17.4	16.8	19.2	15.9	21.3	14.9	23.7
		48	18.5	17.6	17.6	19.5	16.7	21.6	15.7	24.0
		50	19.0	17.8	18.1	19.6	17.2	21.7	16.2	24.1
	RAUC C20 With 25Ton Chiller	40	16.8	17.2	16.0	19.0	15.1	21.0	14.1	23.4
		42	17.4	17.4	16.5	19.2	15.6	21.2	14.6	23.6
		45	18.2	17.6	17.3	19.4	16.4	21.5	15.4	23.8
		48	19.1	17.8	18.2	19.6	17.2	21.8	16.2	24.1
		50	19.7	17.9	18.8	19.8	17.8	21.9	16.7	24.3
25	RAUC C25 With 25Ton Chiller	40	21.0	21.8	20.0	24.1	18.9	26.8	17.8	29.8
		42	21.7	22.0	20.7	24.4	19.5	27.0	18.4	30.1
		45	22.8	22.3	21.7	24.7	20.5	27.4	19.3	30.4
		48	23.9	22.6	22.7	25.0	21.5	27.7	20.3	30.8
		50	24.6	22.8	23.4	25.2	22.2	27.9	20.9	31.0
	RAUC C25 With 30Ton Chiller	40	21.9	22.1	20.8	24.4	19.7	27.1	18.4	30.1
		42	22.7	22.3	21.5	24.6	20.3	27.3	19.1	30.3
		45	23.8	22.6	22.6	24.9	21.4	27.6	20.1	30.7
		48	24.9	22.9	23.7	25.3	22.4	28.0	21.1	31.1
		50	25.7	23.1	24.4	25.5	23.1	28.2	21.8	31.3
30	RAUC C30 With 30Ton Chiller	40	25.4	26.1	24.2	28.9	22.9	32.2	21.5	35.8
		42	26.3	26.3	25.0	29.2	23.6	32.5	22.3	36.1
		45	27.5	26.7	26.2	29.6	24.8	32.9	23.4	36.5
		48	28.9	27.1	27.5	30.0	26.0	33.3	24.5	37.0
		50	29.8	27.3	28.3	30.3	26.9	33.6	25.3	37.3
40	RAUC C40 With 40Ton Chiller	40	34.3	34.2	32.6	37.6	30.8	41.8	28.9	46.4
		42	35.4	34.4	33.7	38.0	31.8	42.2	29.9	46.8
		45	37.1	34.8	35.3	38.4	33.5	42.6	31.5	47.4
		48	38.9	35.2	37.0	39.0	35.1	43.2	33.1	48.0
		50	40.1	35.4	38.2	39.2	36.2	43.4	34.2	48.4
	RAUC C40 With 50Ton Chiller	40	35.4	34.4	33.6	38.0	31.8	42.0	29.8	46.8
		42	36.6	34.6	34.8	38.2	32.8	42.4	30.9	47.2
		45	38.4	35.0	36.5	38.8	33.5	43.0	32.5	47.8
		48	40.7	35.6	38.3	39.2	36.2	43.4	34.1	48.4
		50	41.5	35.8	39.5	39.6	37.4	43.8	35.2	48.6
50	RAUC C50 With 50Ton Chiller	40	42.1	44.0	40.0	48.8	37.8	54.0	35.5	60.2
		42	43.4	44.4	41.3	49.2	39.0	54.6	36.7	60.6
		45	45.5	45.0	43.3	49.8	40.9	55.2	38.5	61.4
		48	47.6	45.6	45.3	50.4	42.9	55.8	40.4	62.0
		50	49.1	46.0	46.7	50.8	44.3	56.4	41.7	62.6
	RAUC C50 With 60Ton Chiller	40	43.3	44.4	41.1	49.0	38.8	54.4	36.4	60.6
		42	44.7	44.8	42.4	49.6	40.1	54.8	37.6	61.0
		45	46.9	45.4	44.5	50.2	42.1	55.6	39.6	61.8
		48	49.1	46.0	46.7	50.8	44.2	56.4	41.5	62.4
		50	50.6	46.4	48.1	51.2	45.6	56.8	42.9	63.0
60	RAUC C60 With 60Ton Chiller	40	50.0	52.2	47.6	58.0	45.0	64.6	42.4	71.8
		42	51.7	52.8	49.2	58.6	46.5	65.2	43.8	72.4
		45	54.2	53.4	51.6	59.4	48.8	66.0	46.0	73.4
		48	56.7	54.2	54.0	60.2	51.2	67.0	48.3	74.4
		50	58.5	54.8	55.7	60.8	52.8	67.4	49.8	75.0
	RAUC C60 With 80Ton Chiller	40	55.1	53.8	52.2	59.6	49.2	66.2	46.1	73.4
		42	56.9	54.2	54.0	60.2	50.9	66.8	47.8	74.2
		45	59.8	55.2	56.7	61.0	53.5	67.8	50.3	75.2
		48	62.7	56.0	59.5	62.0	56.2	68.8	52.8	76.2
		50	64.7	56.6	61.4	62.6	58.0	69.4	54.6	77.0



# Performance Data - 60 Hz

# 50 & 60 Ton Condensing Units

Chart PD-9 - 50 Ton Condensing Unit Performance - RAUC-C50 (60 HZ)

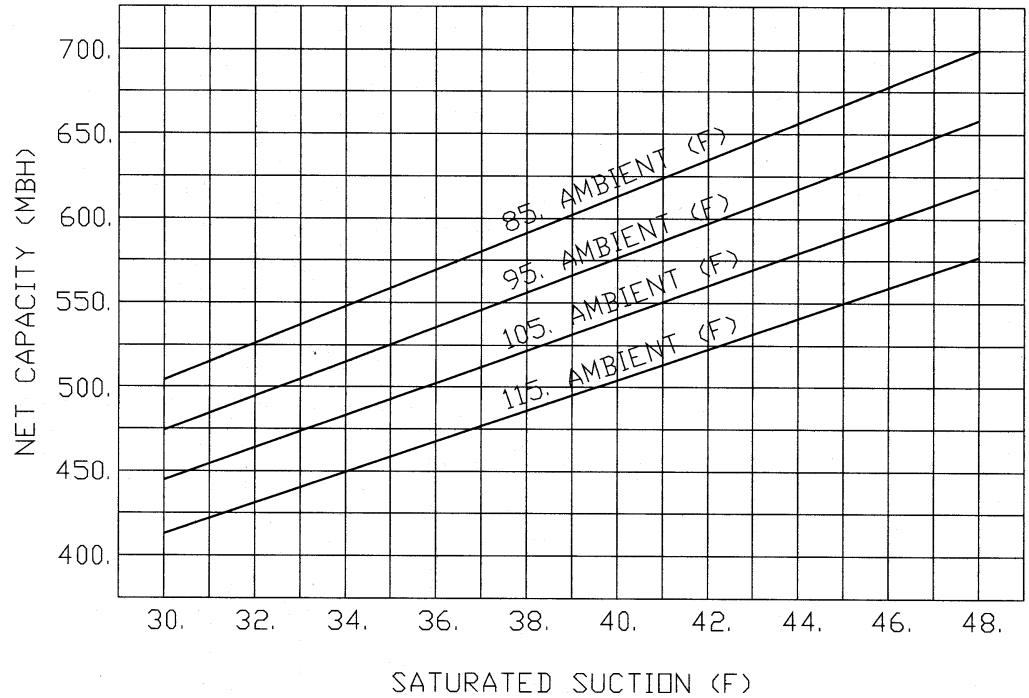
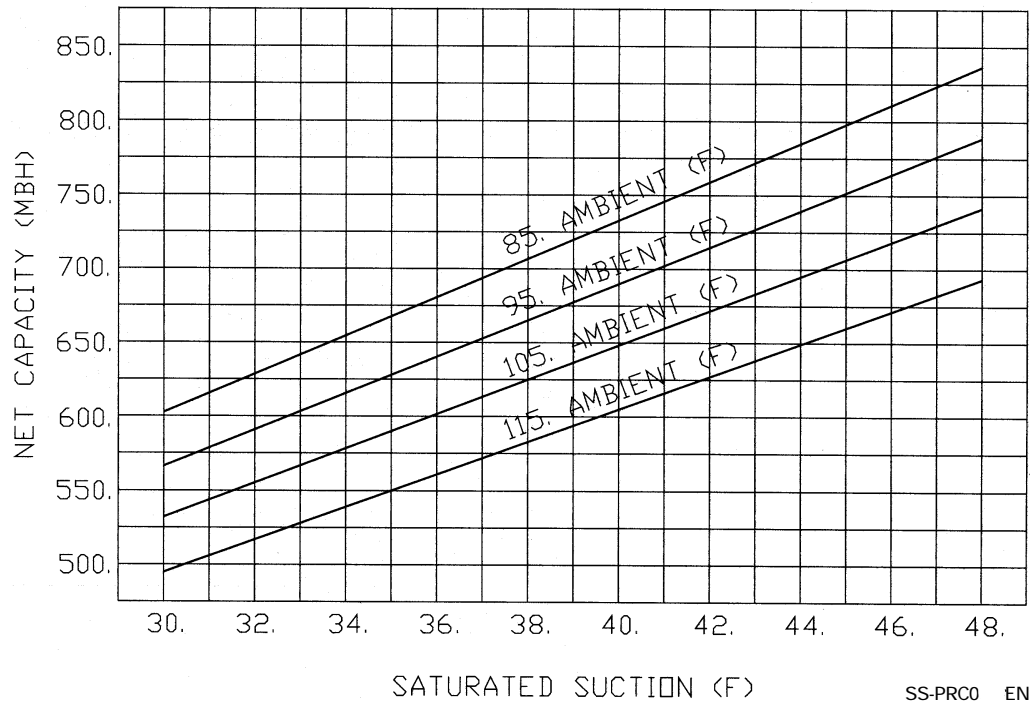

Chart PD-10 - 60 Ton Condensing Unit Performance - RAUC-C60 (60 HZ)



# Controls

# 20-60 Tons

## Standard Options

### 20 through 60-Ton Condensing Units

#### System Control Options

Select one of the four following control options to meet your application requirements.

- **No System Control** provides the compressors wired to a terminal strip inside the control panel. The temperature controller must be field provided and installed. The 20, 25 and 30-ton have two capacity steps. The 40, 50 and 60-ton sizes have four steps available.
- **Constant Volume Control** includes a W973 controller with two cool, four heat steps on the 20, 25 and 30-ton sizes. Four cool, four heat steps are provided on the 40, 50 and 60-ton sizes. The heating contacts are wired to terminals in the condensing unit control panel for easy interface with a field supplied electric duct heater or gas duct furnace. An optional return air sensor is available with this controller which provides the zone temperature input to the thermostat, thus generating the loading demand signal to the Honeywell W973 constant volume controller.
- **Supply Air VAV Control** provides a Honeywell W7100A control system. This option is for use with shut-off VAV or

other applications requiring control of supply air temperature. The control provides a voltage output for interface with field supplied components to provide simultaneous economizer operation. The discharge air sensor ships with the unit for field mounting. The standard VAV unit is provided with reliable coil frost protection in the form of Trane's proven and patented FROSTAT™. FROSTAT is used in place of hot gas bypass.

- **EVP Control** consists of an interface panel in the main unit control box and a remote mounted control box that is customer installed. The remote mounted box contains the Honeywell W7100G controller. This water chiller controller has built in fixed-off timers and chiller freeze protection. No provision for periodic pumpout or lead-lag is provided. Multiple chiller control is not provided. There are two capacity steps on 20, 25 and 30-ton sizes. Four capacity steps are provided on the 40, 50 and 60-ton sizes.

#### Low Ambient Control Option

- **Standard** — Unit start-up and operation down to approximately 40°F at minimum compressor load.

- **Low Ambient** — Factory-installed head pressure control damper assembly permits operation down to 0°F by maintaining proper head pressure. Ten minute timer is standard for protection against nuisance trips.

## Miscellaneous Options

### 20 through 60-Ton Condensing Units

Select the miscellaneous options to meet your project requirements.

- **Non-Fused Unit Disconnect Switch-** A non-fused disconnect switch is mounted in the control box and provides for interruption of power for servicing the unit. Lugs are suitable for copper wires only. No overcurrent or short circuit protection is provided for the unit by this switch.
- **Hot Gas Bypass Valve** — Hot gas bypass valves are stocked and shipped with the unit for field installation. When suction pressure falls below the valve adjustable set point, the valve modulates hot gas to the inlet of the evaporator. (Note: FROSTAT is standard on VAV units and is recommended in place of hot gas bypass).





# Electrical Data

**Table ED-1 –Condensing Units –60 Hz**

Nominal Tons	Model Number	Unit Characteristics					
		Voltage/Start Characteristics	Allowable Voltage Utilization Range	Minimum Circuit Ampacity (1), (4)	Max. Overcurrent Protection Device (2), (4)	Recommended Dual Element Fuse Size (3), (4)	Number Of Compressors
20	RAUC-C20E	200/60/3XL	180-220	101	125	125	2
	RAUC-C20F	230/60/3XL	207-253	101	125	125	2
	RAUC-C204	460/60/3XL	414-506	44	60	50	2
	RAUC-C205	575/60/3XL	517-633	35	45	40	2
25	RAUC-C25E	200/60/3XL	180-220	129	175	150	2
	RAUC-C25F	230/60/3XL	207-253	129	175	150	2
	RAUC-C254	460/60/3XL	414-506	56	80	70	2
	RAUC-C255	575/60/3XL	517-633	45	60	60	2
30	RAUC-C30E	200/60/3XL	180-220	148	200	175	2
	RAUC-C30F	230/60/3XL	207-253	148	200	175	2
	RAUC-C304	460/60/3XL	414-506	65	90	80	2
	RAUC-C305	575/60/3XL	517-633	52	70	60	2
40	RAUC-C40E	200/60/3XL	180-220	192	225	225	4
	RAUC-C40F	230/60/3XL	207-253	192	225	225	4
	RAUC-C404	460/60/3XL	414-506	84	100	90	4
	RAUC-C405	575/60/3XL	517-633	67	80	80	4
50	RAUC-C50E	200/60/3XL	180-220	244	300	300	4
	RAUC-C50F	230/60/3XL	207-253	244	300	300	4
	RAUC-C504	460/60/3XL	414-506	106	125	125	4
	RAUC-C505	575/60/3XL	517-633	84	100	90	4
60	RAUC-C60E	200/60/3XL	180-220	282	300	300	4
	RAUC-C60F	230/60/3XL	207-253	282	300	300	4
	RAUC-C604	460/60/3XL	414-506	123	125	125	4
	RAUC-C605	575/60/3XL	517-633	98	110	110	4
80	RAUC-C80E	200/60/3XL	180-220	373	400	400	6
	RAUC-C80F	230/60/3XL	207-253	373	400	400	6
	RAUC-C804	460/60/3XL	414-506	162	175	175	6
	RAUC-C805	575/60/3XL	517-633	129	150	150	6
100	RAUC-D10E	200/60/3XL	180-220	472	500	500	8
	RAUC-D10F	230/60/3XL	207-253	472	500	500	8
	RAUC-D104	460/60/3XL	414-506	206	225	225	8
	RAUC-D105	575/60/3XL	517-633	164	175	175	8
120	RAUC-D12E	200/60/3XL	180-220	548	600	600	8
	RAUC-D12F	230/60/3XL	207-253	548	600	600	8
	RAUC-D124	460/60/3XL	414-506	239	250	250	8
	RAUC-D125	575/60/3XL	517-633	190	200	200	8

**Notes:**

1. Minimum circuit ampacity (MCA) is 125 percent of the RLA of one compressor motor plus the total RLA of the remaining motors.
2. Maximum Overcurrent Protection Device permitted by NEC 440-22 is 225 percent of the RLA of one compressor motor plus the total RLA of the remaining motors.
3. Recommended dual element fuse size is 150 percent of the RLA of one compressor motor plus the total RLA of the remaining motors.
4. Local codes may take precedence.

**Table ED-2–Condensing Units –50 Hz**

Nominal Tons	Model Number	Unit Characteristics					
		Voltage/Start Characteristics	Allowable Voltage Utilization Range	Minimum Circuit Ampacity (1), (4)	Max. Overcurrent Protection Device (2), (4)	Recommended Dual Element Fuse Size (3), (4)	Number Of Compressors
20	RAUC-C20	380/415/50/3XL	360-440	42	50	50	2
25	RAUC-C25	380/415/50/3XL	360-440	55	80	70	2
30	RAUC-C30	380/415/50/3XL	360-440	64	90	80	2
40	RAUC-C40	380/415/50/3XL	360-440	80	90	90	4
50	RAUC-C50	380/415/50/3XL	360-440	104	125	125	4
60	RAUC-C60	380/415/50/3XL	360-440	122	125	125	4
80	RAUC-C80	380/415/50/3XL	360-440	159	175	175	6
100	RAUC-D10	380/415/50/3XL	360-440	201	225	225	8
120	RAUC-D12	380/415/50/3XL	360-440	237	250	250	8

**Notes:**

1. Minimum circuit ampacity (MCA) is 125 percent of the RLA of one compressor motor plus the total RLA of the remaining motors.
2. Maximum Overcurrent Protection Device permitted by NEC 440-22 is 225 percent of the RLA of one compressor motor plus the total RLA of the remaining motors.
3. Recommended dual element fuse size is 150 percent of the RLA of one compressor motor plus the total RLA of the remaining motors.
4. Local codes may take precedence.



# Electrical Data

**Table ED-3 –Compressor Motor and Condenser Fan Data –60 Hz**

Nominal Tons	Model	Voltage	Compressor 1A (1)		Compressor 1B		Compressor 2A		Compressor 2B		Condenser Fans	
			RLA	LRA	RLA	LRA	RLA	LRA	RLA	LRA	Qty.	FLA
20	RAUC-C20	200 XL	41.4	269	41.4	269	—	—	—	—	2	4.1
		230 XL	41.4	251	41.4	251	—	—	—	—	2	4.1
		460 XL	18.1	117	18.1	117	—	—	—	—	2	1.8
		575 XL	14.4	94	14.4	94	—	—	—	—	2	1.4
25	RAUC-C25	200 XL	41.4	269	60.5	409	—	—	—	—	3	4.1
		230 XL	41.4	251	60.5	376	—	—	—	—	3	4.1
		460 XL	18.1	117	26.3	178	—	—	—	—	3	1.8
		575 XL	14.4	94	21.0	143	—	—	—	—	3	1.4
30	RAUC-C30	200 XL	60.5	409	60.5	409	—	—	—	—	3	4.1
		230 XL	60.5	376	60.5	376	—	—	—	—	3	4.1
		460 XL	26.3	178	26.3	178	—	—	—	—	3	1.8
		575 XL	21.0	143	21.0	143	—	—	—	—	3	1.4
40	RAUC-C40	200 XL	41.4	269	41.4	269	41.4	269	41.4	269	4	4.1
		230 XL	41.4	251	41.4	251	41.4	251	41.4	251	4	4.1
		460 XL	18.1	117	18.1	117	18.1	117	18.1	117	4	1.8
		575 XL	14.4	94	14.4	94	14.4	94	14.4	94	4	1.4
50	RAUC-C50	200 XL	41.4	269	60.5	409	41.4	269	60.5	409	6	4.1
		230 XL	41.4	251	60.5	376	41.4	251	60.5	376	6	4.1
		460 XL	18.1	117	26.3	178	18.1	117	26.3	178	6	1.8
		575 XL	14.4	94	21.0	143	14.4	94	21.0	143	6	1.4
60	RAUC-C60	200 XL	60.5	409	60.5	409	60.5	409	60.5	409	6	4.1
		230 XL	60.5	376	60.5	376	60.5	376	60.5	376	6	4.1
		460 XL	26.3	178	26.3	178	26.3	178	26.3	178	6	1.8
		575 XL	21.0	143	21.0	143	21.0	143	21.0	143	6	1.4
Nominal Tons	Model	Voltage	Compressor 1A/2A(2)		Compressor 1B/2B		Compressor 1C/2C		Compressor 1D/2D		Condenser Fans	
			RLA	LRA	RLA	LRA	RLA	LRA	RLA	LRA	Qty.	FLA
80	RAUC-C80	200 XL	41.4	269	60.5	409	60.5	409	—	—	8	4.1
		230 XL	41.4	251	60.5	376	60.5	376	—	—	8	4.1
		460 XL	18.1	117	26.3	178	26.3	178	—	—	8	1.8
		575 XL	14.4	94	21.0	143	21.0	143	—	—	8	1.4
100	RAUC-D10	200 XL	60.5	409	60.5	409	41.4	269	41.4	269	12	4.1
		230 XL	60.5	376	60.5	376	41.4	251	41.4	251	12	4.1
		460 XL	26.3	178	26.3	178	18.1	117	18.1	117	12	1.8
		575 XL	21.0	143	21.0	143	14.4	94	14.4	94	12	1.4
120	RAUC-D12	200 XL	60.5	409	60.5	409	60.5	409	60.5	409	12	4.1
		230 XL	60.5	376	60.5	376	60.5	376	60.5	376	12	4.1
		460 XL	26.3	178	26.3	178	26.3	178	26.3	178	12	1.8
		575 XL	21.0	143	21.0	143	21.0	143	21.0	143	12	1.4

Notes:

1. Value given is per compressor on 20-60 ton units.
2. For 80 through 120-ton units, electrical values shown are for each compressor.

**Table ED-4 –Compressor Motor and Condenser Fan Data –50 Hz**

Nominal Tons	Model	Voltage	Compressor 1A (1)		Compressor 1B		Compressor 2A		Compressor 2B		Condenser Fans	
			RLA	LRA	RLA	LRA	RLA	LRA	RLA	LRA	Qty.	FLA
20	RAUC-C20	380/415	17.2	110	17.2	110	—	—	—	—	2	1.7
25	RAUC-C25	380/415	17.2	110	26.2	174	—	—	—	—	3	1.7
30	RAUC-C30	380/415	26.2	174	26.2	174	—	—	—	—	3	1.7
40	RAUC-C40	380/415	17.2	110	17.2	110	—	—	—	—	4	1.7
50	RAUC-C50	380/415	17.2	110	26.2	174	—	—	—	—	6	1.7
60	RAUC-C60	380/415	26.2	174	26.2	174	—	—	—	—	6	1.7
Nominal Tons	Model	Voltage	Compressor 1A/2A(2)		Compressor 1B/2B		Compressor 1C/2C		Compressor 1D/2D		Condenser Fans	
			RLA	LRA	RLA	LRA	RLA	LRA	RLA	LRA	Qty.	FLA
80	RAUC-C80	380/415	17.2	174	26.2	174	26.2	174	—	—	8	1.7
100	RAUC-D10	380/415	26.2	174	26.2	174	17.2	110	17.2	110	12	1.7
120	RAUC-D12	380/415	26.2	174	26.2	174	26.2	174	26.2	174	12	1.7

Notes:

1. Value given is per compressor on 20-60 ton units.
2. For 80 through 120-ton units, electrical values shown are for each compressor.



# Dimensional Data

# 60Ton Condensing Unit

Figure DD-6 - Air-Cooled Condensing Unit - RAUC 60 Ton

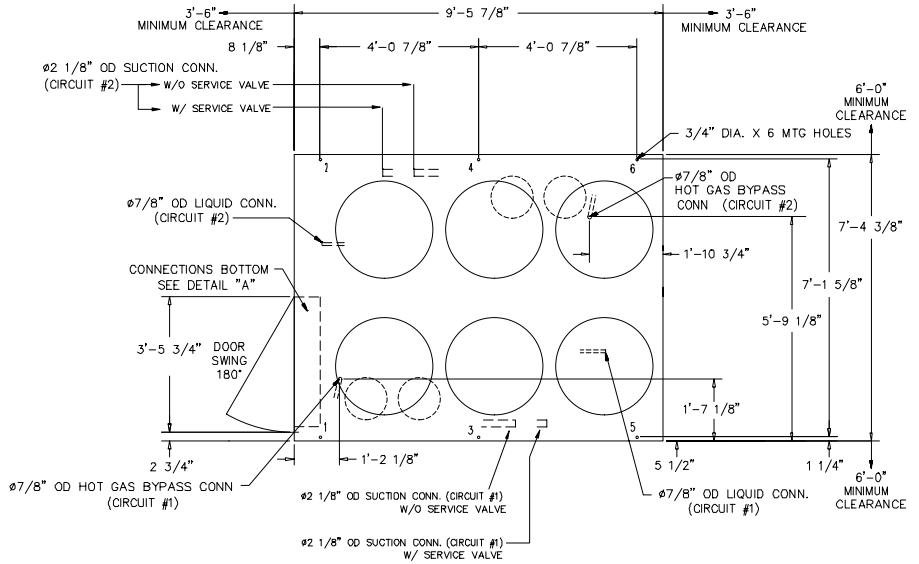

TOP VIEW

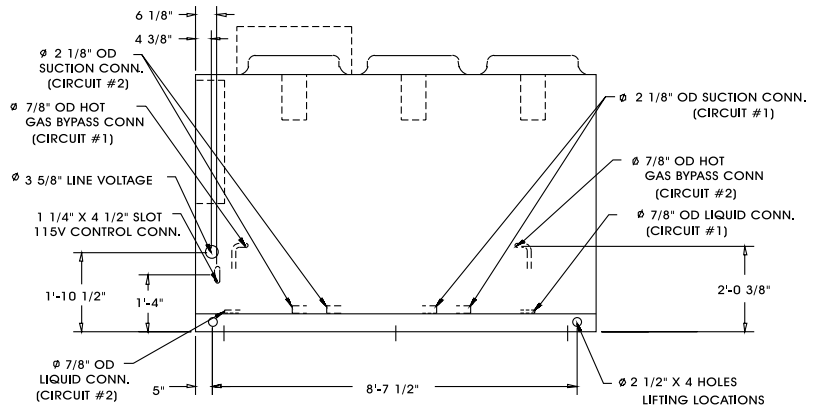

FRONT VIEW

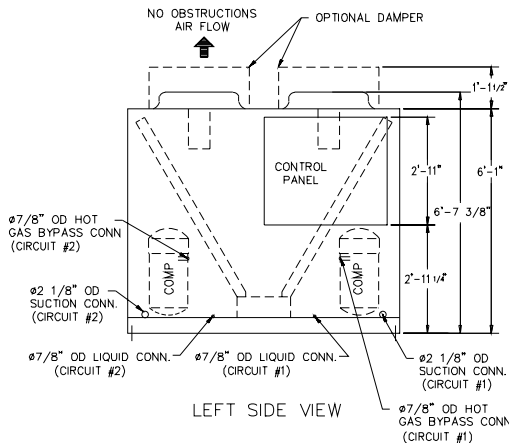

LEFT SIDE VIEW

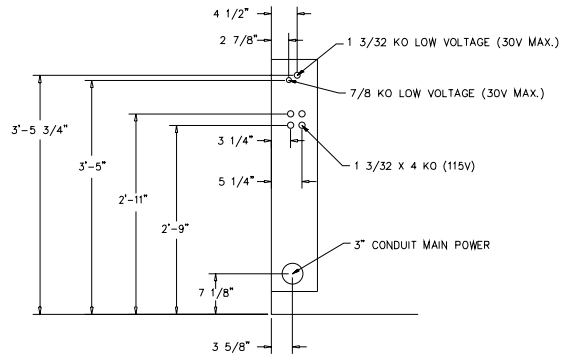

DETAIL "A"

# Dimensional Data

# 50 Ton and 60 Ton Evaporator Chiller

Figure DD-13 - 50 and 60-Ton Evaporator Chiller

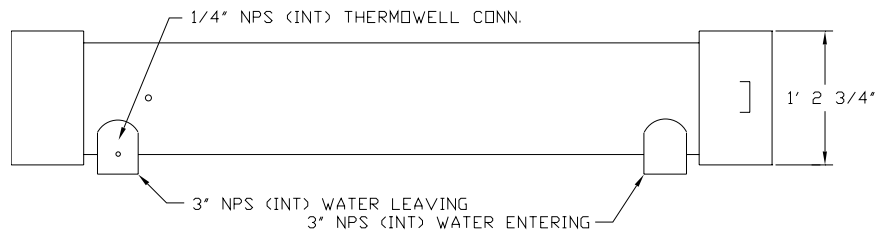

TOP VIEW

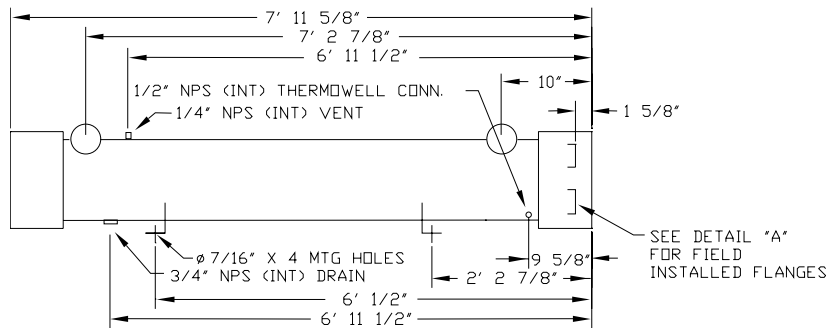

FRONT VIEW

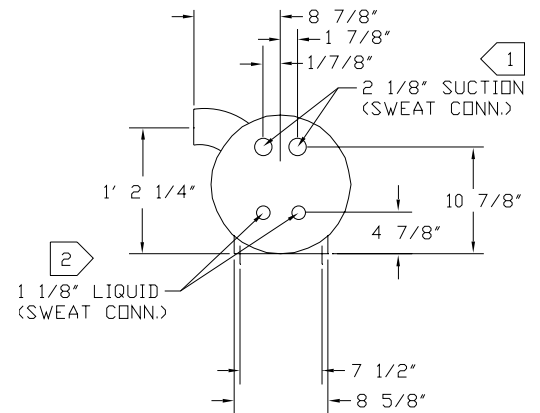

RIGHT SIDE VIEW

**NOTES:**

1. DIMENSIONAL TOLERANCE IS  $\pm 1/8"$ .
2. ALLOW 8'0" TUBE REMOVAL CLEARANCE EITHER END OF EVAPORATOR

# Weights

**Table W-1 –20-60 Ton Air-Cooled Condensing Units**

Nominal Tons	Model	Operating Weight (Lbs.)		Weight On Isolator At Mounting Locations (Lbs.)											
		AL	CU	Loc. 1		Loc. 2		Loc. 3		Loc. 4		Loc. 5		Loc. 6	
				AL	CU	AL	CU	AL	CU	AL	CU	AL	CU	AL	CU
20	RAUC-C20	1522	1720	509	559	398	439	345	404	270	317	—	—	—	—
25	RAUC-C25	1640	1842	555	602	421	467	378	436	286	338	—	—	—	—
30	RAUC-C30	1824	2115	580	640	635	708	291	364	318	403	—	—	—	—
40	RAUC-C40	2769	3102	480	523	457	501	473	528	450	506	466	533	443	511
50	RAUC-C50	3148	3540	586	643	562	620	536	601	514	579	485	559	465	538
60	RAUC-C60	3480	4050	640	722	618	703	590	684	570	666	540	646	522	629

Note:  
Shipping weight is approximately equal to operating weight.  
AL = Aluminum Coil Fin  
CU = Copper Coil Fin

**Figure W-1 –20-30 Ton Air-Cooled Condensing Units**

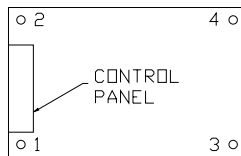

Top View (Mounting Locations)

**Figure W-2 –40-60 Ton Air-Cooled Condensing Units**

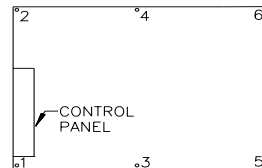

**Table W-2 –80-120 Ton Air Condensing Units**

Nominal Tons	Model	Coil Fin	Operating Weight (Lbs.)	Weight On Isolator At Mounting Location (Lbs.)							
				Loc. 1	Loc.2	Loc. 3	Loc.4	Loc. 5	Loc. 6	Loc. 7	Loc. 8
80	RAUC-C80	AL	5500	855	557	835	544	830	541	810	528
	RAUC-C80	CU	6099	926	629	909	618	906	616	890	605
100	RAUC-D10	AL	6472	1010	656	983	639	979	636	951	618
	RAUC-D10	CU	7272	1104	762	1083	738	1080	736	1058	721
120	RAUC-D12	AL	7000	1100	694	1075	678	1071	676	1046	660
	RAUC-D12	CU	8199	1241	838	1225	827	1222	825	1206	815

**Figure W-3-80-120 Ton Air-Cooled Condensing Units**

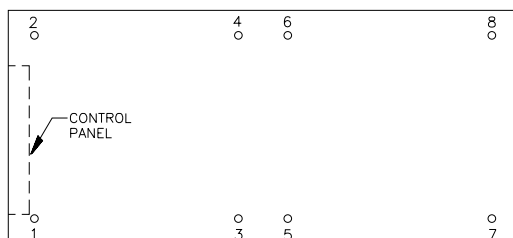

**Table W-3 –Evaporative Chillers 20 through 120 Ton**

Nominal Tons	Operating Weight (Lbs.)	Shipping Weight (Lbs.)
20	360	280
25	360	280
30	470	360
40	480	380
50	580	430
60	600	470
80	1205	875
100	1230	960
120	1535	1150



# Mechanical Specifications

## 20 through 60-ton Condensing Units

### General

All air-cooled condensing units have scroll compressors and are factory assembled and wired. Each unit is shipped from the factory with a nitrogen holding charge. Units are constructed of 14-gauge welded galvanized steel frame with 14 and 16-gauge galvanized steel panels and access doors. Unit surface is phosphatized and finished with an air-dry paint. This air-dry paint finish is durable enough to withstand a 1000-consecutive-hour salt spray application in accordance with standard ASTM B117.

### Compressor

Trane 3-D™ Scroll compressors have simple mechanical design with only three major moving parts. Scroll type compression provides inherently low vibration. The 3-D Scroll provides a completely enclosed compression chamber which leads to increased efficiency. Exhaustive testing on the 3-D Scroll, including start up with the shell full of liquid, has proven that slugging does not fail involutes. Direct-drive, 3600 rpm, suction gas-cooled hermetic motor. Trane 3-D Scroll compressor includes centrifugal oil pump, oil level sightglass and oil charging valve.

### Condenser

Condenser coils have configured aluminum fins mechanically bonded to copper tubing with an integral subcooler. Condensers are factory leak tested at 450 psig air pressure underwater. Direct drive vertical discharge fans are statically and dynamically balanced. Three-phase motors have permanently lubricated ball bearings and thermal overload protection. Optional low ambient allows operating down to 0°F with external damper assembly for head pressure control.

### Refrigerant Circuits and Capacity Modulation

20 through 30-ton sizes are single circuit and have two steps of capacity. The 40 through 60-ton sizes are two circuits with four capacity steps. Each circuit has two compressors piped in parallel. Discharge and liquid line service valves are standard on each circuit.

### Unit Control

Factory-provided 115-volt control circuit includes fusing and control power transformer. The unit is wired with magnetic contactors for compressor and condenser motors, three-leg, solid-state compressor overload protection, and high-low pressure cutouts. Charge isolation, reset relay and anti-recycle compressor timer are provided.

## 80 through 120-ton Condensing Units

### Casing

The unit frame is a one-piece welded assembly of heavy gauge zinc-coated steel. Exterior surfaces are phosphatized and finished with slate gray air-dry paint. This air-dry paint finish exceeds 672 consecutive hour salt spray resistance in accordance with ASTM B117. Decorative louvered panels provide factory standard condenser coil protection.

### Compressors

Trane 3-D® Scroll compressors have a simple mechanical design with only three major moving parts. Scroll type compression provides inherently low vibration. The 3-D Scroll provides a completely enclosed compression chamber which leads to increased efficiency. Exhaustive testing on the 3-D Scroll, including start up with the shell full of liquid, has proven that slugging does not fail involutes. Direct-drive, 3600 rpm, suction gas-cooled hermetic motor. Trane 3-D Scroll compressor includes centrifugal oil pump, oil level sightglass and oil charging valve.

Split systems can have significantly more refrigerant than packaged systems and thus require controls to reliably manage this excess refrigerant. Each compressor shall have crankcase heaters installed, properly sized to minimize the amount of liquid refrigerant present in the oil sump during off cycles. Additionally, the condensing unit shall have controls to initiate a refrigerant pump down cycle at system shut down on each refrigerant circuit. To be operational, the refrigerant pump down cycle requires a field-installed isolation solenoid valve on the liquid line near the evaporator.

### Condenser Fan and Motors

Vertical discharge direct-drive fans are statically and dynamically balanced. Fan motors are three-phase with permanently lubricated ball bearings, built-in current and thermal overload protection.

### Condenser Coil

Condenser coils have configured aluminum fins mechanically bonded to 3/8-inch OD copper tubing. Two refrigerant circuits with separate subcooling circuits are standard. Coils are factory-tested at 450 psig air pressure underwater and vacuum dehydrated.

### Unit Control

Factory-provided 115-volt control circuit includes fusing and control power transformer. The unit is wired with magnetic contactors for compressor and condenser motors, three-leg, solid-state compressor overload protection, and high-low pressure cutouts. Charge isolation, reset relay and anti-recycle compressor timer are provided.

## 20 through 120-ton Evaporator Chiller

Shell and tube design with seamless copper tubes expanded into tube sheets with removable heads. 20, 25 and 30-ton units are single-circuited; 40 through 120-ton are dual-circuited. The 20-60 ton evaporators are designed for a water side working pressure of 300 psig. 70-120 ton evaporators are designed for 150 psig water side working pressure. The units are designed, tested and stamped in accordance with the ASME Code for unfired pressure vessels for a refrigerant side working pressure of 225 psig. Evaporator chillers are provided with fittings for temperature sensors and a drain plug for cleaning.