

Description: 2025-99 UNIT R.H.  
 Sold To: DALY LINEA  
 Date: \_\_\_\_\_  
 Ship To: \_\_\_\_\_  
 Date: \_\_\_\_\_  
 Title: \_\_\_\_\_  
 Job Number: A602-001  
 Quantity: \_\_\_\_\_

ITEM NO	Part Number	Quantity	Description	Unit	Notes
1	8001-001	1	BASE ASS'Y	IN	
2	8001-002	1	TOP PANEL ASS'Y	IN	
3	8001-003	1	SUCK PANEL 30" X 30"	IN	
4	8001-004	1	CORNER PANEL 30" X 30"	IN	
5	8001-005	2	CORNER PANEL 42" X 42"	IN	
6	8001-006	2	SIDE PANEL 18" X 72"	IN	
7	8001-007	2	ABOVE DOOR PANEL 24" X 48"	IN	
8	8001-008	2	ABOVE DOOR PANEL 24" X 48"	IN	
9	8001-009	2	ABOVE 1 BELOW DOOR PANEL 24" X 48"	IN	
10	8001-010	2	ABOVE 1 BELOW DOOR PANEL 24" X 48"	IN	
11	8001-011	2	BELOW DOOR PANEL 24" X 48"	IN	
12	8001-012	1	GRILL DAMPER ASS'Y	IN	
13	8001-013	1	PREFILTER CLAMPER	IN	
14	8001-014	1	GROUNDING COIL CLAMPER	IN	
15	8001-015	1	HEATING COIL CLAMPER	IN	
16	8001-016	1	DAMPER MOTOR ASS'Y	IN	
17	8001-017	1	TRANSITION	IN	
18	8001-018	1	FINAL FILTER CLAMPER	IN	
19	8001-019	1	SHIPPING BELT FRAME	IN	
20	8001-020	1	HAT CHANNEL ASS'Y	IN	
21	8001-021	2	LIFTING LUG	IN	
22	8001-022	2	PROTECTION PLATE 20" X 6"	IN	
23	8001-023	4	24" X 60" ACCESS DOOR	IN	
24	8001-024	4	RAIN GUARD	IN	

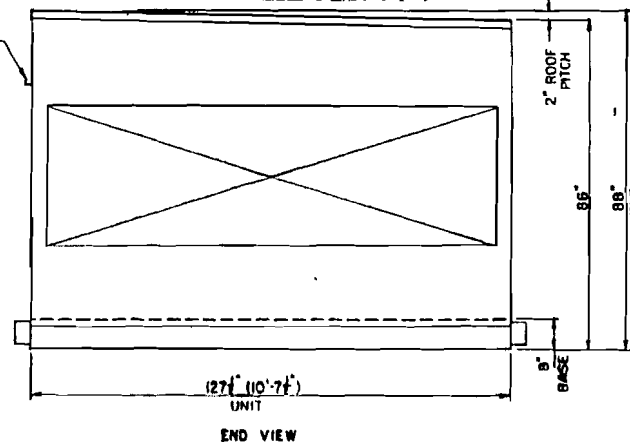
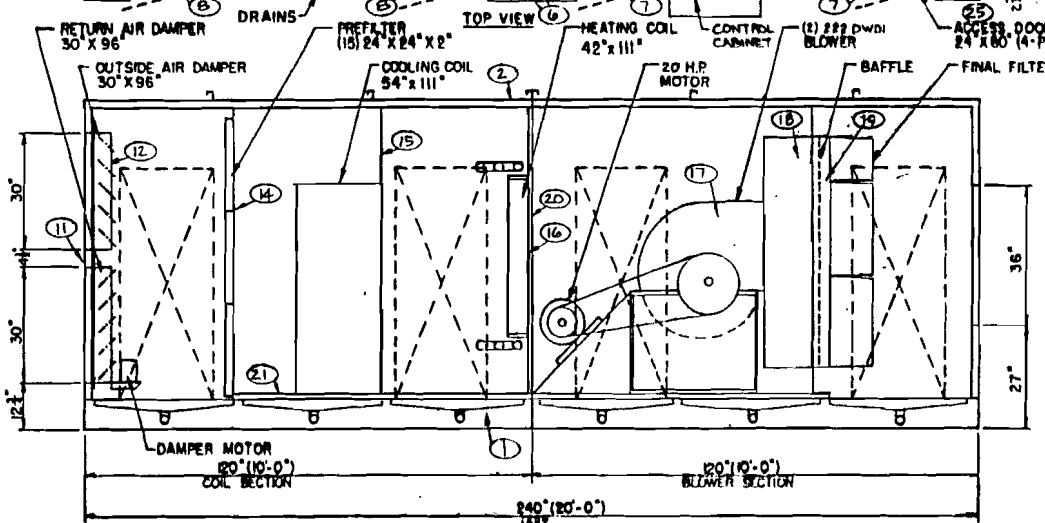

Project Manager: \_\_\_\_\_  
 Notes:  
 Rev. A: \_\_\_\_\_  
 Rev. B: \_\_\_\_\_  
 Rev. C: \_\_\_\_\_  
 Rev. D: \_\_\_\_\_  
 Rev. E: \_\_\_\_\_  
 (1) Rework on unit  
 (2) Rework on parts  
 (3) Part not tested  
 (4) Part not released  
 (5) Special purchase  
 (6) Ship direct

Total Cost of Parts: \_\_\_\_\_  
 Labor Hours: \_\_\_\_\_  
 Total Cost: \_\_\_\_\_  
 No. of Units: \_\_\_\_\_  
 Each Unit: \_\_\_\_\_  
 Shop Order No.: \_\_\_\_\_

**NOTE**  
 ALL EXT. (INT. FASTENERS ARE TO BE 102499) FASTENERS TO BE SELF DRILLER)  
 CAULK ALL SEAMS W/102181 (SILICONE SEALANT)  
 PAINT EXTERIOR OF UNIT WITH 102215 (GREY ENAMEL)

2025-99 VENT. UNIT R.H.

2946

THE KING CO. A602-001

# DX AMMONIA PIPING

— CREAMER ROOM —  
Y 2037 A

CUSTOMER : TUSCAN DAIRY DATE 3-17-88  
UNION, NEW JERSEY

KLIMATIC KING MODEL NO. 2025-99 AIR VOLUME 20,000 CFM  
COOLING CAPACITY: 70 TONS USING +35° °F SUCTION TEMP.  
Δ °F ENTERING AIR, Δ °F LEAVING AIR  
COIL CONNECTION 1/38 DIST IPS INLET, 2" IPS OUTLET  
PIPE SIZE          IPS INLET,          IPS OUTLET

VALVES SUPPLIED (2) AAE-30-L EXPANSION VALVES - 3/4" FPT -  
(2) MA-17 SOLENOIDS - 24V COIL - 3/4" FLANGED -  
(2) SPORLAN B006 STRAINER - 3/4" FPT -

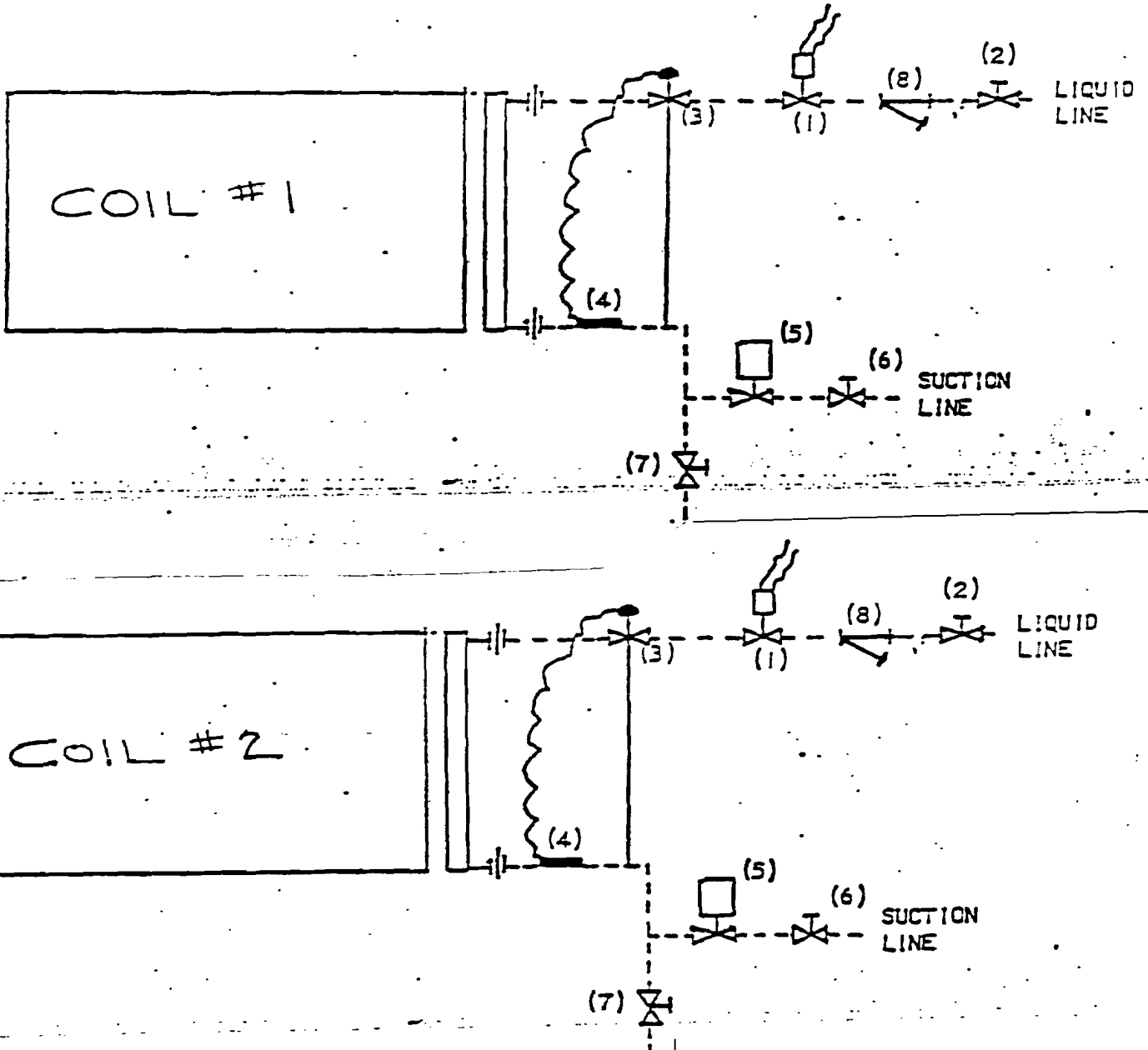

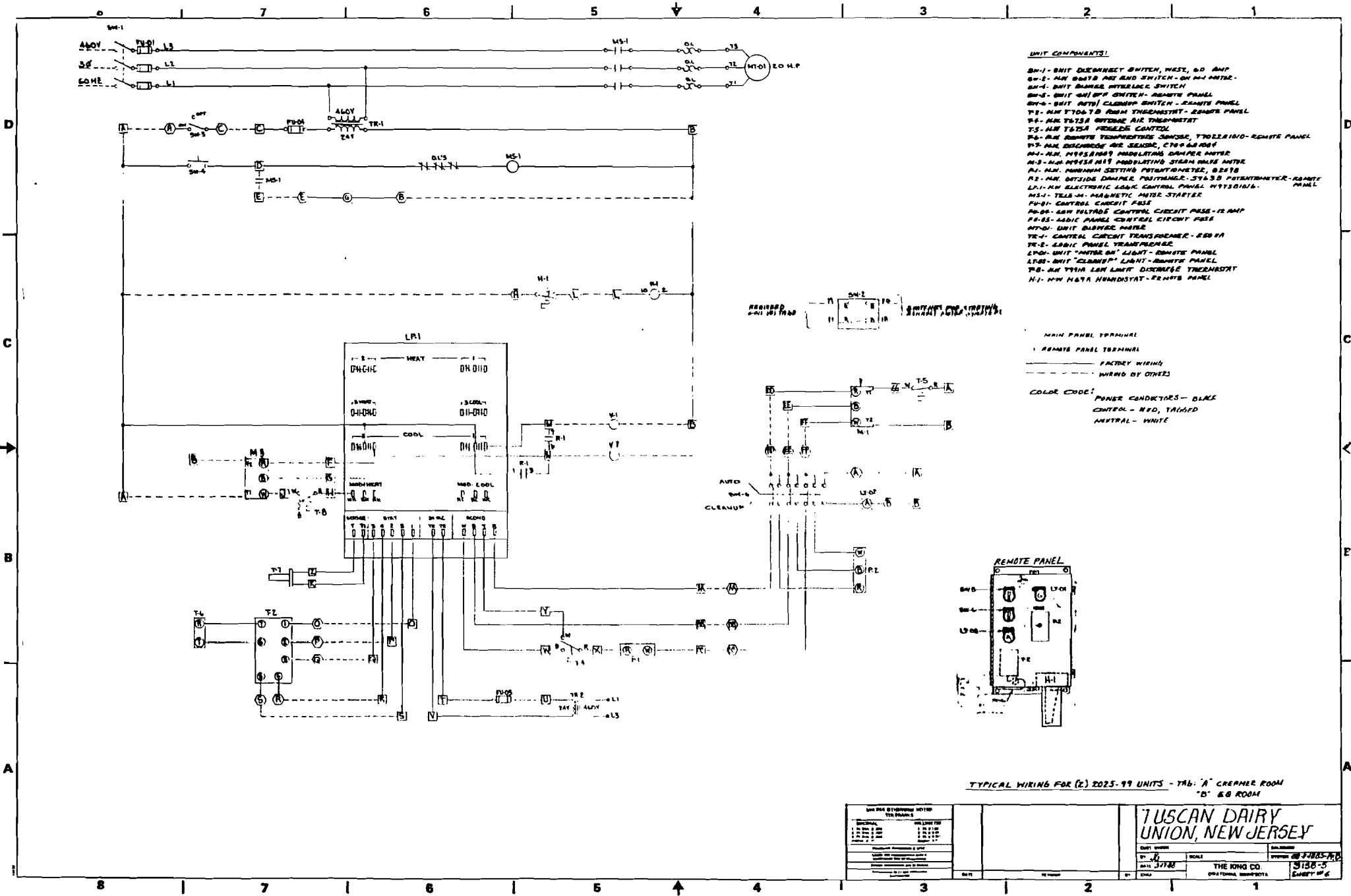

- UNIT COMPONENTS:**
- M-01 - UNIT DISCONNECT SWITCH, 60 AMP
  - M-02 - MAIN SWITCH AND FUSE SWITCH ON MAIN PANEL
  - M-04 - UNIT DAMPER INTERLOCK SWITCH
  - M-05 - UNIT ON/OFF SWITCH - REMOTE PANEL
  - M-06 - UNIT AUTO CLEANUP SWITCH - REMOTE PANEL
  - T-1 - 240V TO 240V FROM TRANSFORMER - REMOTE PANEL
  - T-2 - 240V TO 240V OUTSIDE AIR THERMISTAT
  - T-3 - AIR T-1/5A FUSE/LEAD CONTROL
  - T-4 - AIR REMOTE TEMPERATURE SENSOR, THERMISTAT - REMOTE PANEL
  - T-5 - AIR DISCONNECT AND SENSOR, CTR 60 AMP
  - M-07 - AIR HYDRAULIC REGULATING VALVE/RELIEF VALVE
  - M-08 - AIR PRESSURE REGULATING STEAM GAGE/VALVE
  - M-09 - AIR PRESSURE REGULATING POTENTIOMETER, 0-250
  - M-10 - AIR OUTSIDE DAMPER POSITIONER - 5/16 S.S. POTENTIOMETER - REMOTE PANEL
  - LP-1 - AIR ELECTRONIC LOGIC CONTROL PANEL HYDRO/10/10
  - M-11 - TELL-TALE MAGNETIC FUSE STATICS
  - F-01 - CONTROL CIRCUIT FUSE
  - M-03 - LOW VOLTAGE CONTROL CIRCUIT FUSE - 1/2 AMP
  - F-02 - LOGIC PANEL CONTROL CIRCUIT FUSE
  - M-04 - UNIT SERVICE MOTOR
  - T-01 - CONTROL CIRCUIT TRANSFORMER - 250 VA
  - T-02 - LOGIC PANEL TRANSFORMER
  - LP-01 - UNIT "AUTO ON" LIGHT - REMOTE PANEL
  - LP-02 - UNIT "CLEANUP" LIGHT - REMOTE PANEL
  - M-12 - AIR T-1/5A LOW LIMIT DISCONNECT THERMISTAT
  - M-13 - NEW HATA HANDSTAT - REMOTE PANEL

**MAIN PANEL TERMINAL**  
**REMOTE PANEL TERMINAL**  
 SOLID LINE FACTORY WIRING  
 DASHED LINE WIRING BY OTHERS

**COLOR CODE:**  
 POWER CONDUCTORS - BLACK  
 CONTROL - RED, YELLOW  
 NEUTRAL - WHITE

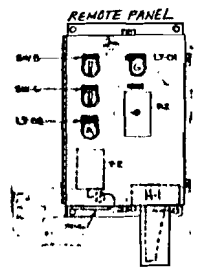

TYPICAL WIRING FOR (2) 2025-99 UNITS - TAB "A" CREPHER ROOM  
 "B" E.G. ROOM

NEW YORK ELECTRICAL SYSTEMS TELEPHONE 5		<b>7U5CAN DAIRY          UNION, NEW JERSEY</b>	
UNIT NUMBER BY: J. J. J.	SCALE DATE: 5/78	DRAWING NUMBER THE RONG CO.	PROJECT NUMBER 5158-5
THE RONG CO. 1000 FEDERAL STREET NEW YORK, N.Y. 10038		5158-5 SHEET # 6	

EQ ROOM & CREAMER ROOM  
 V2037B V2037A

Cust.: TUSCAN DAIRY Date: 3-17  
UNION, NEW JERSEY

Klimatic King Model No. 2025-99

Unit Air Capacity: 20,000 C.F.M.

Heating Capacity: 1,728,000 BTU.

                     °F (D.B.) Entering Air

                     °F (D.B.) Leaving Air

80 °F Temperature Rise

Steam Pressure: 15 LBS. at the Steam Coil

Pounds of Condensate: 1827 LBS.

Coil Connection: 2 1/2" IPS Inlet, 1 1/2" IPS Outlet.

(2) Steam Valve Model 501161103 Cv = 40,  
2" Connections.

Vacuum Breaker: (2) 1/2"

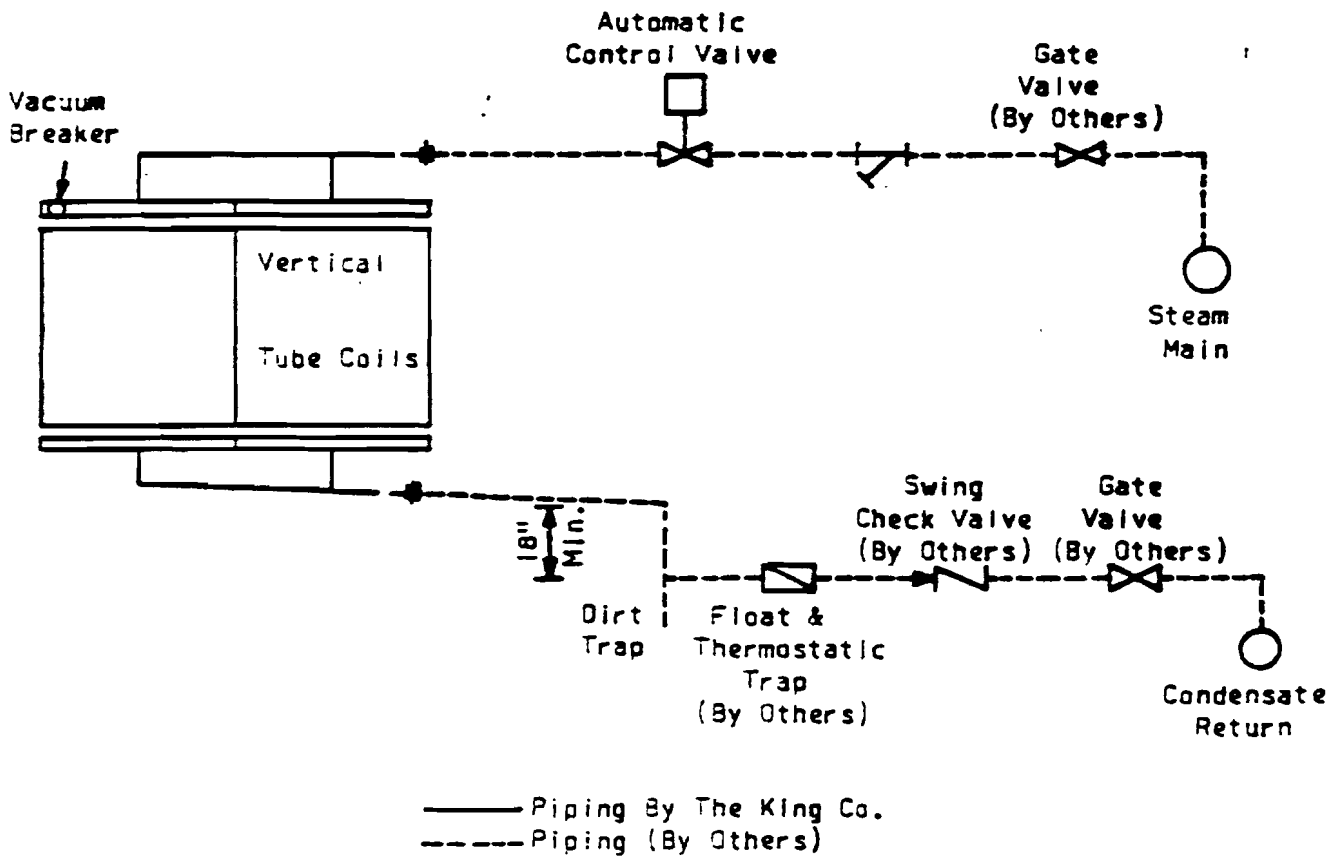

SEE NOTES ON REVERSE SIDE

## Operation:

During normal operation, the unit will attempt to use outside air for cooling of the room whenever possible. If cooling is required, the room thermostat will first modulate the outside air dampers open in an attempt to cool the room.

Whenever the outdoor temperatures are above the room thermostat setting, it is not practical to bring in outside air for cooling. Therefore, at this time, the T-4 outdoor thermostat will close the outside air dampers to a pre-determined minimum set point as determined by potentiometer P-1. The dampers will be maintained in this position as long as the outside temperature is above the room temperature.

The system also includes an operate/clean-up switch located in the remote panel. When in the automatic position, the system will operate as described above. However, when the switch is placed in the clean-up position, the remote potentiometer P-2 is used to manually control the outside and return air dampers. This control allows the outside air volumes to be increased during clean-up or to be decreased during non-operating periods.

## Check-Out:

First, place the operate/clean-up switch in the operate position. Also, place the T-4 outdoor air thermostat to its highest setting. Now place the room thermostat, T-2, to its lowest setting. If at this time the room temperature is above this setting, it should cause the outside air dampers to completely open and the return air dampers to completely close. If this functions properly, now place the T-4 outdoor thermostat in its lowest setting. In this position, it should allow the P-1 potentiometer to control the outside air dampers. Rotating P-1 to the closed position should cause the outside air dampers to close and rotating it to the open position should cause the outside air dampers to open. If this functions properly, rotate the P-1 potentiometer so that the outside air dampers are approximately one-quarter inch open, or of a sufficient setting to supply pressurization of the area.

Now place the operate/clean-up switch in the clean-up position. This will allow the P-2 potentiometer to control the dampers. Rotating the P-2 potentiometer to the open position should cause the outside air dampers to open and rotating it to the closed position should cause the outside air dampers to close.

If this functions properly, return the operate/clean-up switch to the operate position, and return the T-4 outdoor thermostat to the desired room temperature setting.

## Modulating Steam

### Components:

M-3 Motor - Honeywell M945A Modulating Steam Valve (Hot Water or Glycol) Motor. The valve, motor, and linkage are shipped loose for field mounting and wiring.

### Operation:

The logic controller, LP-01, is used to directly modulate the steam valve (water or glycol) to maintain room temperatures.

### Check-Out:

Place the T-2 room controller to the highest setting. Also adjust a T-8 modulating thermostat to its lowest setting. If at this time the room temperature is below this setting, it should cause the motorized steam valve, to completely open. If this functions properly, now place the T-2 room controller to its lowest setting. If at this time the room temperature is above this setting, this should cause the motorized steam valve to close.

## Refrigerant Cooling Control

### Components:

V-1, V-2, and ... Valve - Liquid Line Solenoid Valve. The liquid line solenoid valve and any other refrigeration valves, when supplied, are shipped loose for field mounting and wiring. Please note that the liquid line solenoid valve is designed for 24 volt control.

### Operation:

The LP-01 electronic control module is used to directly control the liquid line solenoid valve(s). The logic panel can incorporate up to three steps of cooling.

### Check-Out:

First place the T-2 room controller to the lowest setting. If at this time the room temperature is above this setting, it will first cause the outside air dampers to completely open. Once the dampers are open, the first stage (followed by second and third) will be energized, causing the liquid line solenoid valve to open. If this functions properly, now place the T-2 controller to the highest setting. If at this time the room temperature is below this setting, it will first de-energize the liquid line solenoid valve(s). It will then close the outside air dampers. If this functions properly, return the room thermostat to its desired room setting.

## Dehumidification Control

### Components:

H-1 Dehumidistat - Honeywell H69A Dehumidistat. The dehumidistat is located in the unit remote panel with the sensing element under the panel.

### Operation:

Whenever dehumidification is required, the dehumidistat will fully open the refrigeration control valve. In this mode, the unit will provide maximum cooling and therefore, maximum dehumidification. The heating coil will remain in the circuit and the room temperature will modulate the heating coil to maintain room temperatures and provide reheat if necessary.

### Check-Out:

First place the T-2 room controller in its highest setting. At this time, the outside air dampers should be closed and the refrigeration valve(s) should also be closed. Now rotate the H-1 dehumidistat to its lowest humidity setting. If at this time the humidity is above this setting, it should fully open the refrigeration valve. If this functions properly, rotate the dehumidistat to its highest humidity setting. If at this time the humidity is below that set point, it should close the refrigeration valve. If this functions properly, now place the dehumidistat at the desired set point.

### Exhaust Control - One or Two Stage

#### Components:

SW-2 Switch - Honeywell Q607B Auxiliary Switch located on the outside air damper motor, M-1.

#### Operation:

The exhaust unit(s) will be staged on as the outside air dampers open. As the outside air dampers reach approximately 50 percent open, the first stage will be energized. As the outside air dampers approach 85 percent open, the second stage will be energized. In this way, the exhaust units are automatically controlled and yet maintain a pressurization within the room. Starters and disconnects for the exhausts are to be supplied by others.

#### Check-Out:

First, place the auto/clean-up switch in the clean-up position. Now rotate the P-2 potentiometer to the open position. As the outside air dampers reach approximately 50 percent open, the first stage exhaust will be energized. As the dampers reach approximately 85 percent open, the second stage exhaust will be energized. If this functions properly, now place the operate/clean-up switch to the operate position.

### Steam Coil Freeze Protection

#### Components:

T-5 Freezestat - Honeywell T675A. This thermostat is located on the discharge side of the steam coil with its sensing bulb located in the coil discharge air stream.

T-3 Low Limit Discharge - Honeywell T991A. This thermostat is located in the final filter section with its sensing bulb in the supply airstream.

Operation:

The freezestat, T-5, & the low limit stat, T-3, should be set at 38° & 45° respectively. This will allow the outside air damper to close and return air damper to open if the discharge temperature of the steam coil falls below 38°F and if the supply air temperature should fall below 45°F, T-3 will modulate the steam valve open in order to maintain the supply air temperature above 45°.

Blower Motor Control

Components:

SW-1 Switch - Fused Disconnect Switch located on the exterior of the King unit.

MS-1 Starter - Definite Purpose Magnetic Motor Starter located in the unit control panel. The starter is 24 volt control.

SW-5 Switch - Unit On/Off Switch located on the unit's remote panel.

SW-4 Switch - Safety Door Interlock Switch located in the unit's blower access door.

Operation:

During normal operation, the unit on/off switch, SW-5, will directly control the unit motor starter, MS-1. However, the system includes a safety door interlock switch, SW-4, that will de-energize the motor starter whenever the unit blower motor access door is opened. The system also includes a fused disconnect switch, SW-1. This is used to disconnect all power to the King unit for servicing or maintenance.

NOTE: THE FUSED DISCONNECT SWITCH, SW-1, MUST BE IN THE OFF POSITION FOR ANY SERVICING, MAINTENANCE, OR INSPECTION OF THE KING UNIT.



## STEAM PIPING NOTES

1. The piping diagrams on the reverse side show one of many acceptable piping methods. Important: Pipe steam coil in accordance with State and Local Codes.
2. To reduce freeze hazard, maintain ample operating pressure and check trap performance.
3. Pitch all supply and condensate piping away from the steam coil.
4. The entire system must be designed and piped to prevent accumulation of condensate at any point.
5. We recommend providing drip legs and traps at all low spots or natural drainage points such as: ahead of risers, ends of mains, ahead of expansion joints or bends and ahead of valves and regulators. Where there is no natural drainage points, drip legs and traps should be provided at intervals no longer than about 500 feet.
6. A full pipe strainer should be installed ahead of each control valve.
7. A vacuum breaker is used to relieve any unwanted vacuum condition within the steam coil. Preferable to locate at the inlet of the steam coil.
8. Locate dirt traps inside where they will not freeze.
9. Steam main and steam supply lines must be kept dry.
10. A condensate by pass line may be included where continuity of service is necessary or to permit trap removal when repairs are required.
11. Due to the large variety of makes, types and applications, it is difficult to advise on a specific make or type of trap. Consult your trap manufacturer for complete trap data.
12. Use swing joints whenever there may be possible damage caused by expansion and contraction of piping and steam coil.

#### AMMONIA PIPING NOTES

1. The piping diagrams on the reverse side show one of many acceptable piping methods. Important: Pipe ammonia coil in accordance with State and Local Codes.
2. It is important that the unit be installed with the piping in such a way that the unit can be isolated for repair of leaks or coil maintenance.
3. It is considered good practice to locate a stop valve in the inlet and outlet lines to the coil and in long lengths of piping to the coil to permit them to be isolated in case of leaks and to facilitate pumping out.
4. A relief vent should be installed around the stop valves in the suction line.
5. A strainer should be used in front of control valves to protect them from pipe construction material and dirt.
6. Solenoid valves should be installed upright.
7. Slope suction piping away from the coil.
8. Pipe complete system so as to prevent accumulation of oil in valves, controls and the evaporator coil.
9. The evaporator coil should be piped with an easily accessible oil drain.

CUSTOMER: TUSCAN DAIRY  
UNION, NEW JERSEY

FIRST STAGE

EXHAUST UNIT MODEL: BY OTHERS

MOTOR VOLTAGE: \_\_\_\_\_

SECOND STAGE

EXHAUST UNIT MODEL: BY OTHERS

MOTOR VOLTAGE: \_\_\_\_\_

SINGLE.  
SPEED EXHAUST  
UNITS

This is a supplement to the Klimatic King  
Unit wiring diagram 3158-5 sheet #6

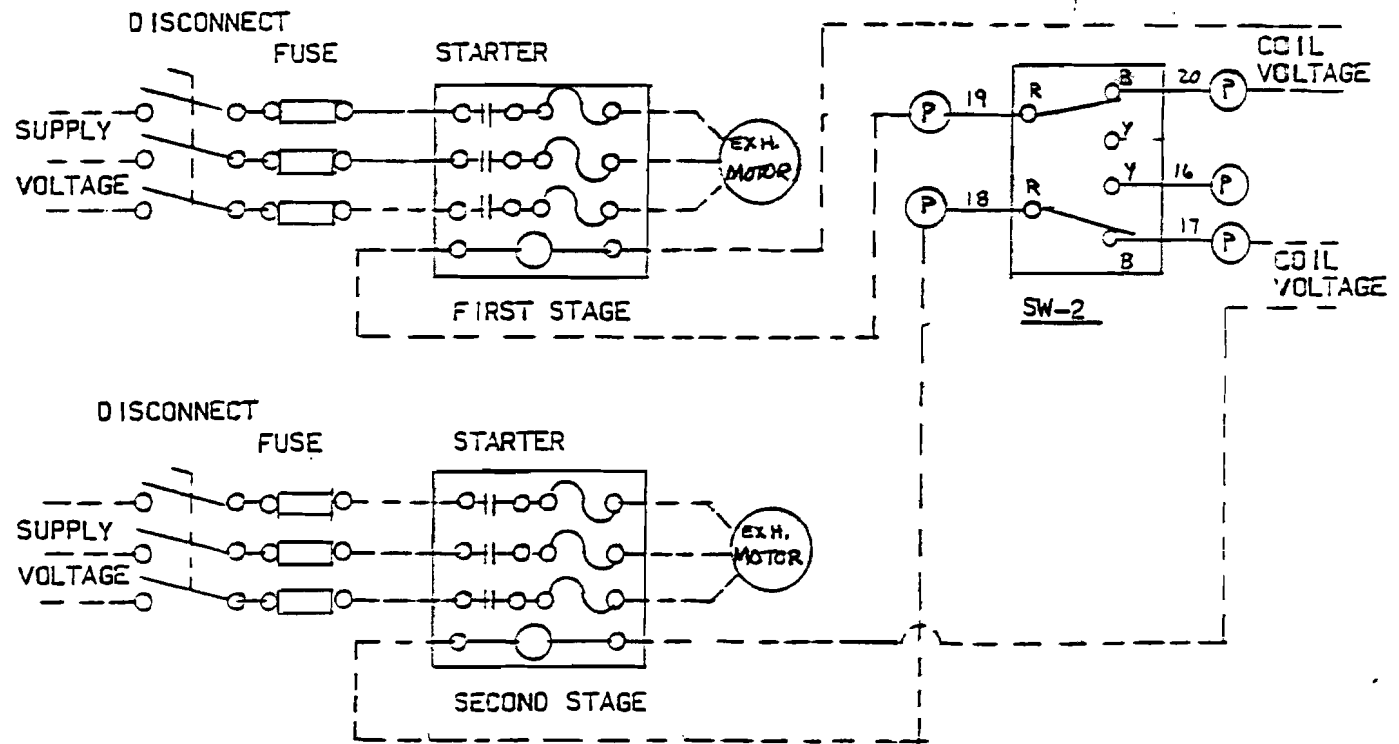

- NOTE: 1. DISCONNECT, FUSE AND MOTOR STARTER SUPPLIED, WIRED AND INSTALLED BY OTHERS.  
2. END SWITCH (SW-2) AND P JUNCTION BOX MOUNTED AND WIRED BY THE KING CO.  
3. - - - - WIRING BY OTHERS, \_\_\_\_\_ WIRING BY KING CO.

			"P" PRESSURIZATION CONTROL EXHAUST MOTOR WIRING	
BY	REVISION	DATE		
DRAWN BY: K.F.V.	CHKD. BY:	DATE: 12/16/82:	ASSEMBLY OR SYSTEM	
MATERIAL:			THE KING CO. OWATONNA MINN.	
SCALE:			VFE-101-C	